

1 PLAN: 6TH FLR. PROJECT SCOPE
 1 SCALE: NOT TO SCALE

DRAWING NUMBER
MW1

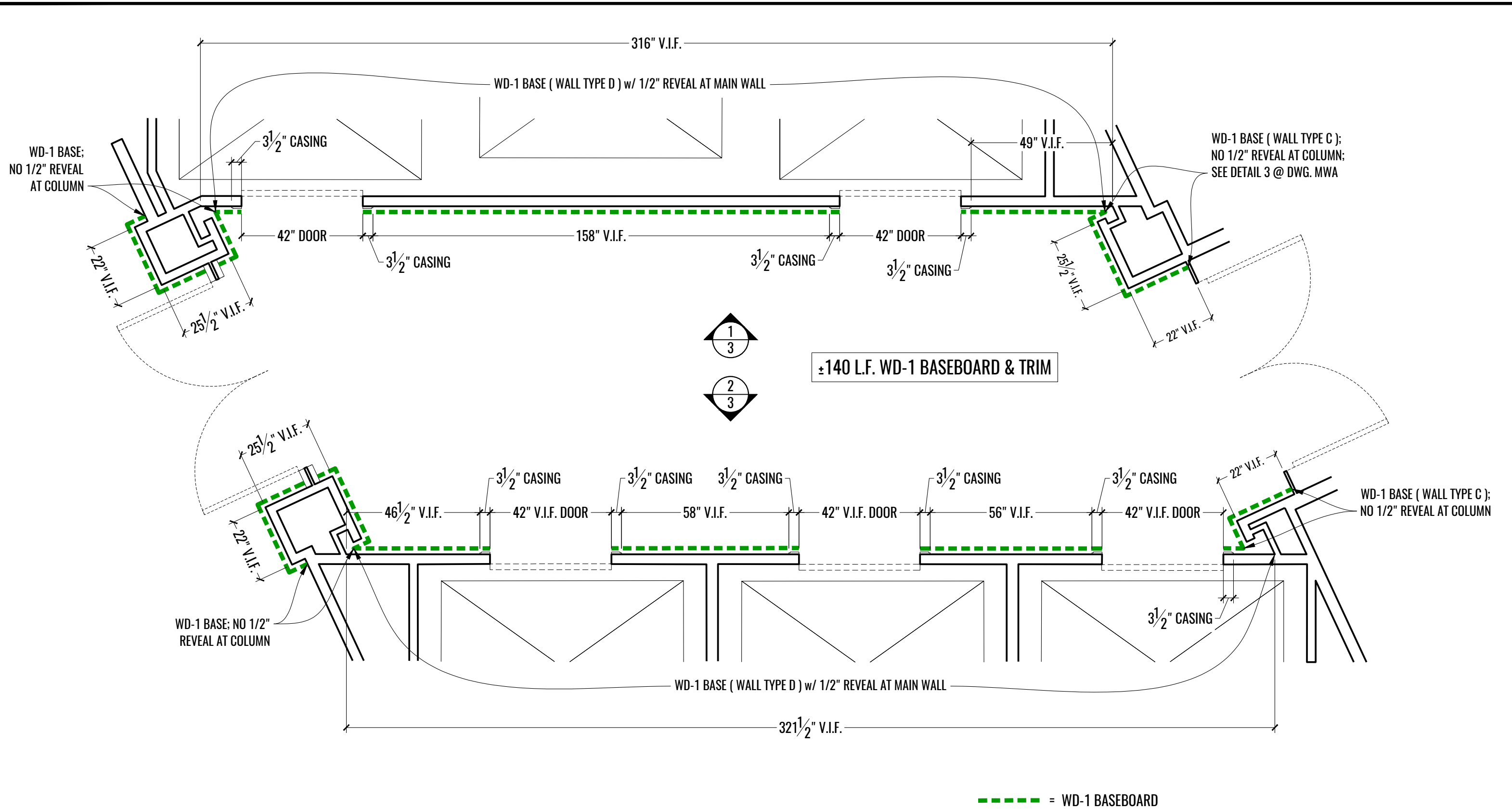

±140 L.F. WD-1 BASEBOARD & TRIM

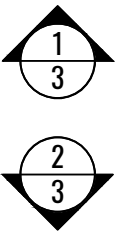

1 PLAN: ELEVATOR LOBBY BASEBOARD & TRIM
 2 SCALE: 3/8" = 1'-0"

----- = WD-1 BASEBOARD

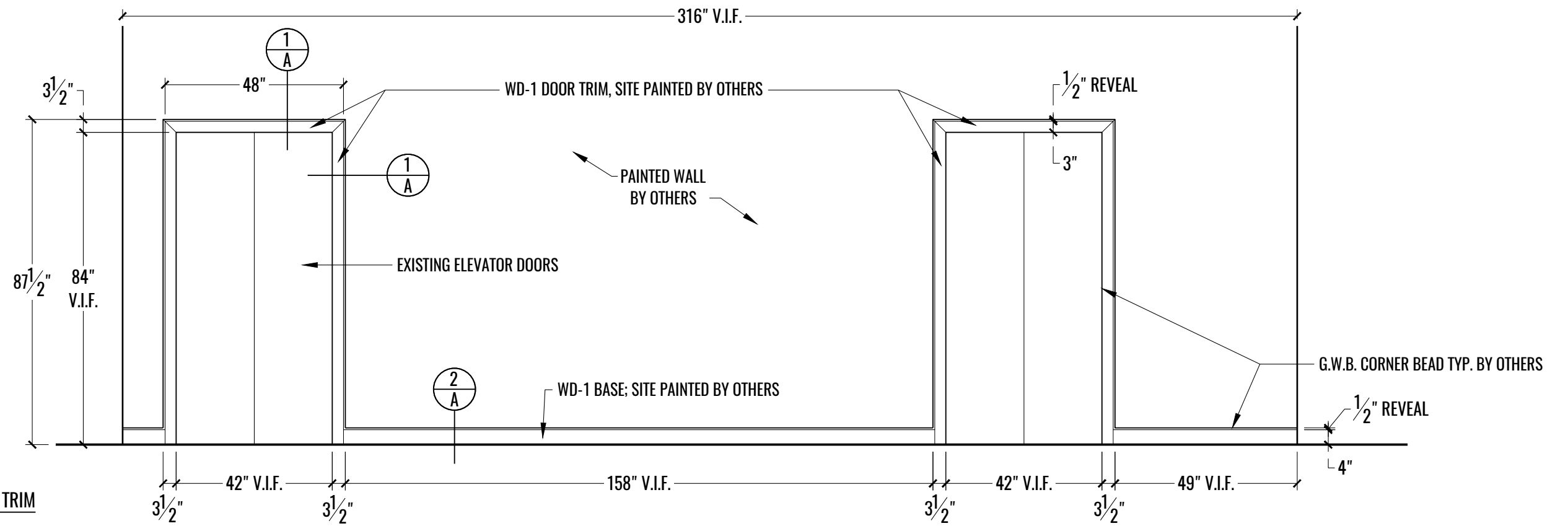

1
3 ELEVATION: ELEVATOR LOBBY TRIM
SCALE: 3/8" = 1'-0"

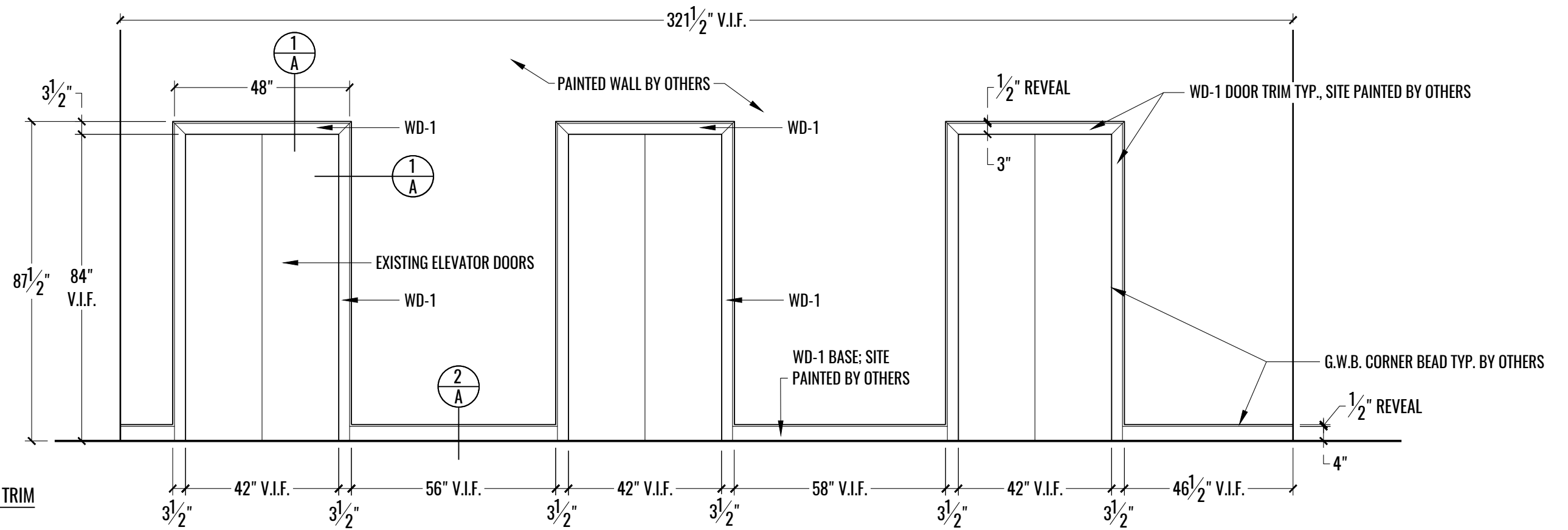

2
3 ELEVATION: ELEVATOR LOBBY TRIM
SCALE: 3/8" = 1'-0"

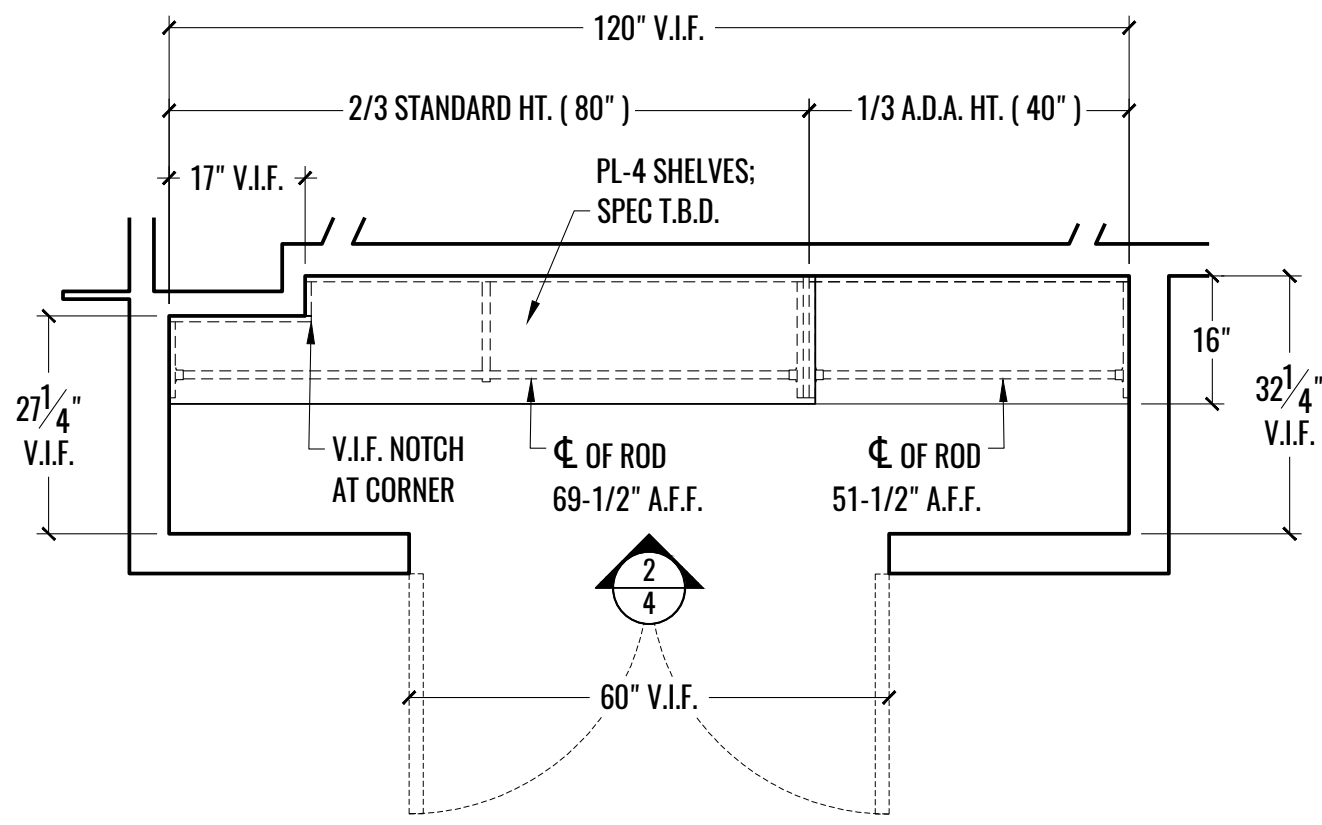

1 PLAN: COAT CLOSET 607
 4 SCALE: 1/2" = 1'-0"

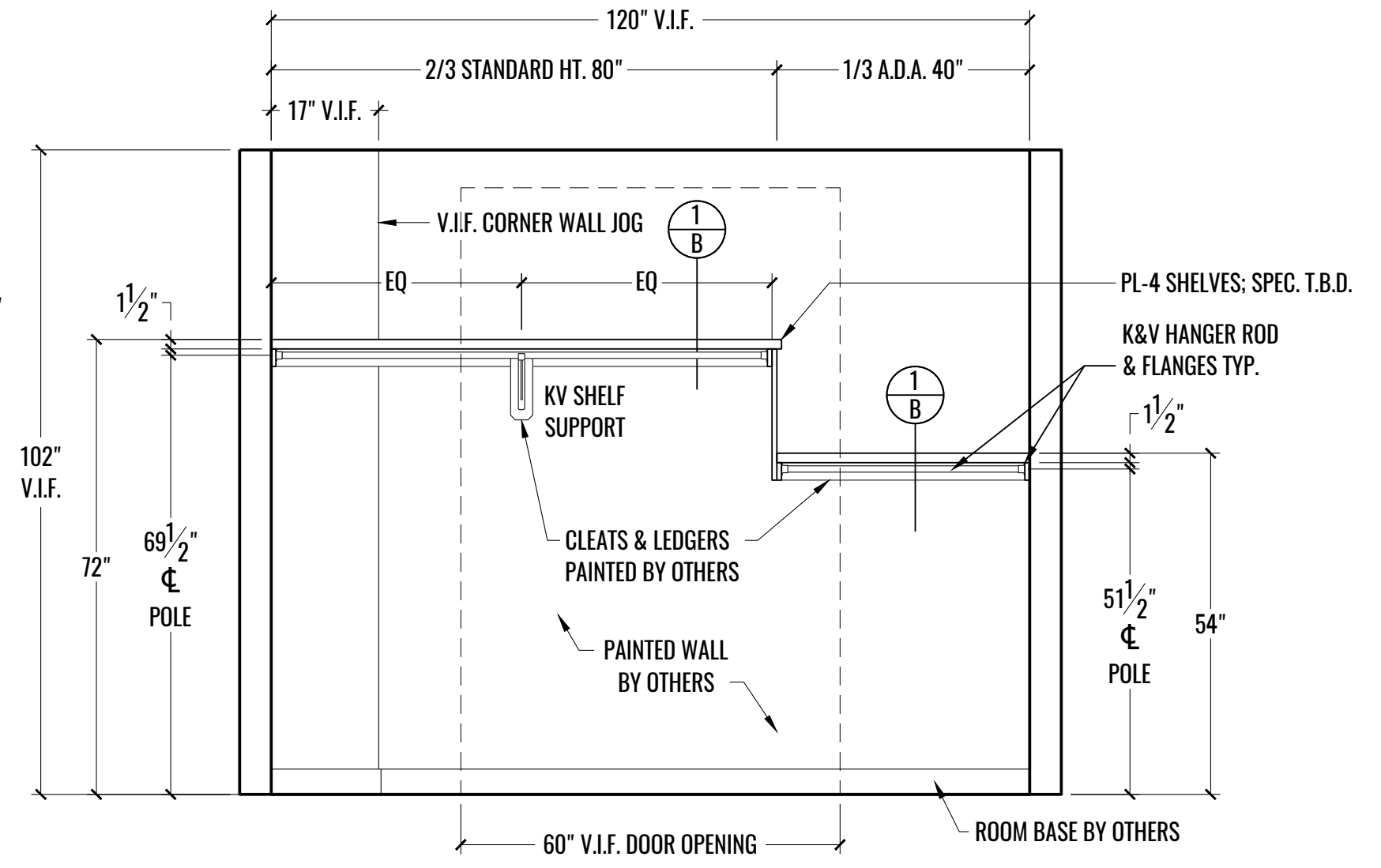

2 ELEVATION: COAT CLOSET 607
 4 SCALE: 1/2" = 1'-0"

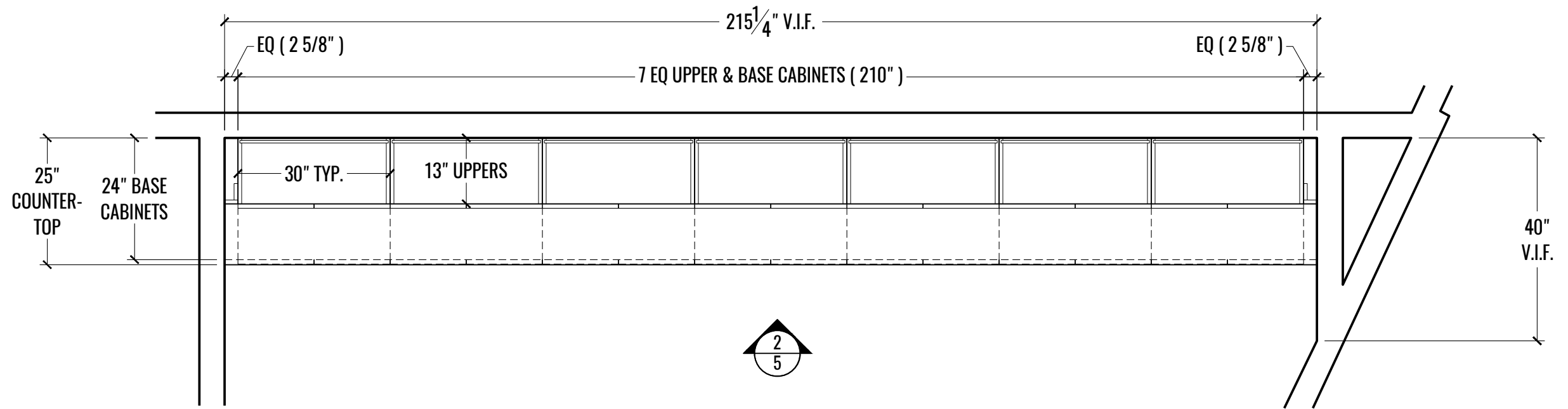

1 PLAN: COPY / MAIL ROOM 605
5 SCALE: 1/2" = 1'-0"

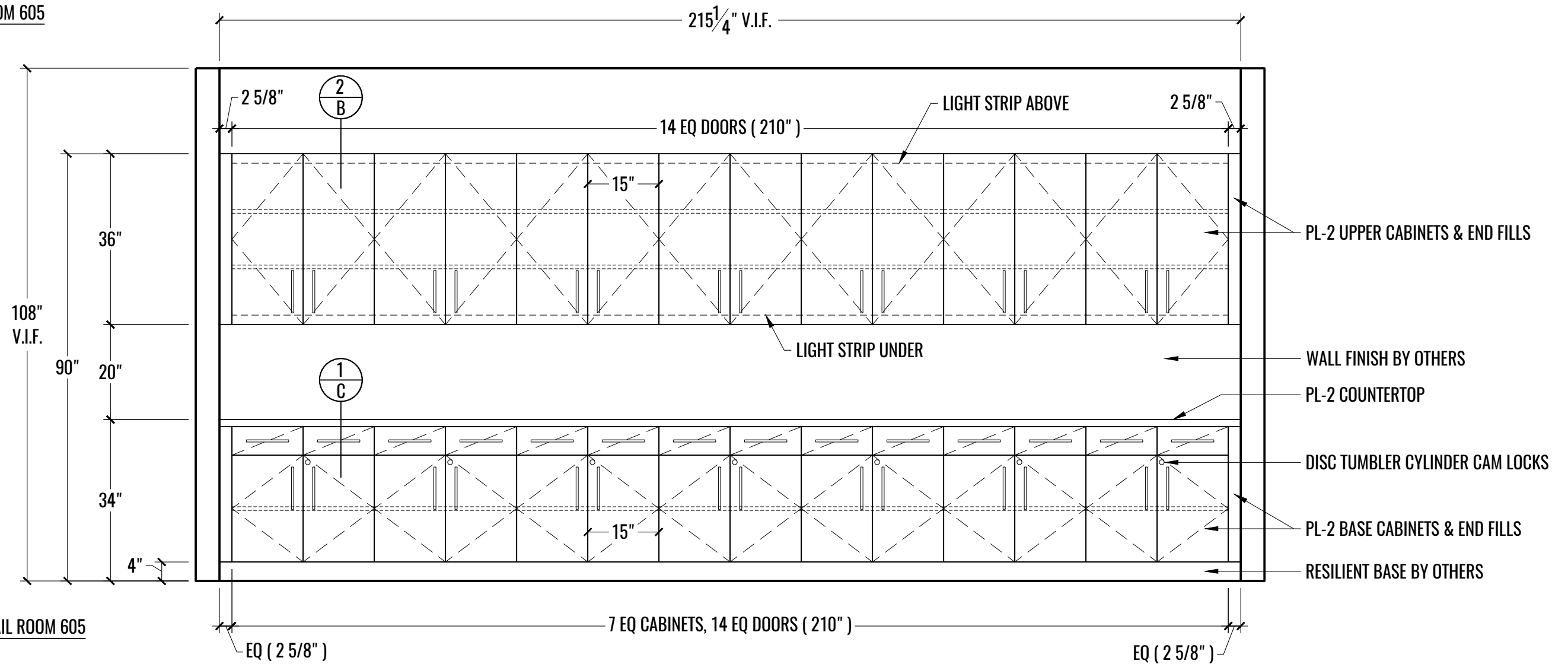

2 ELEVATION: COPY / MAIL ROOM 605
5 SCALE: 1/2" = 1'-0"

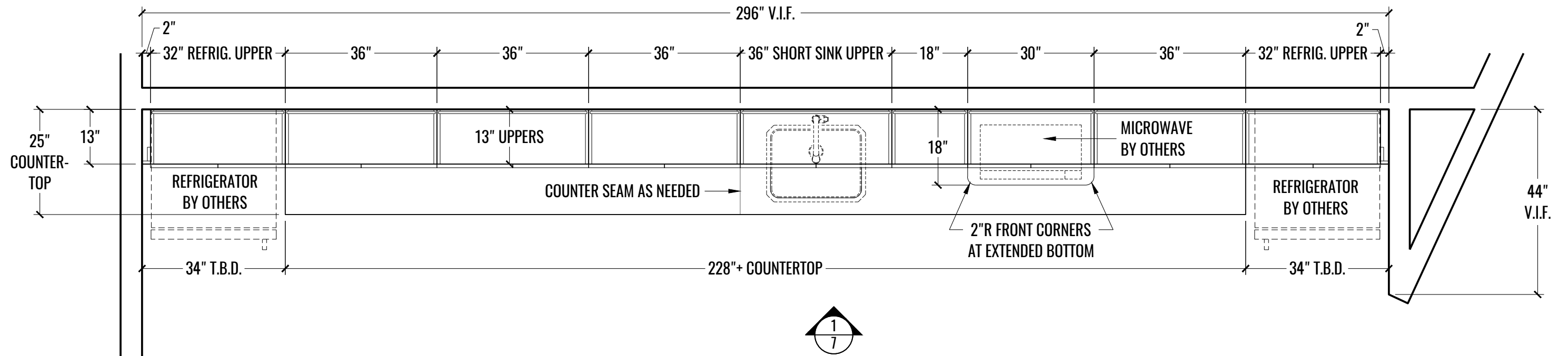

1 PLAN: KITCHENETTE 603 UPPER CABINETS
6 SCALE: 1/2" = 1'-0"

ALL APPLIANCES & FIXTURES BY OTHERS: GENERAL CONTRACTOR TO CONFIRM INSTALLATION FOR PROPER FIT PER CUT SHEETS

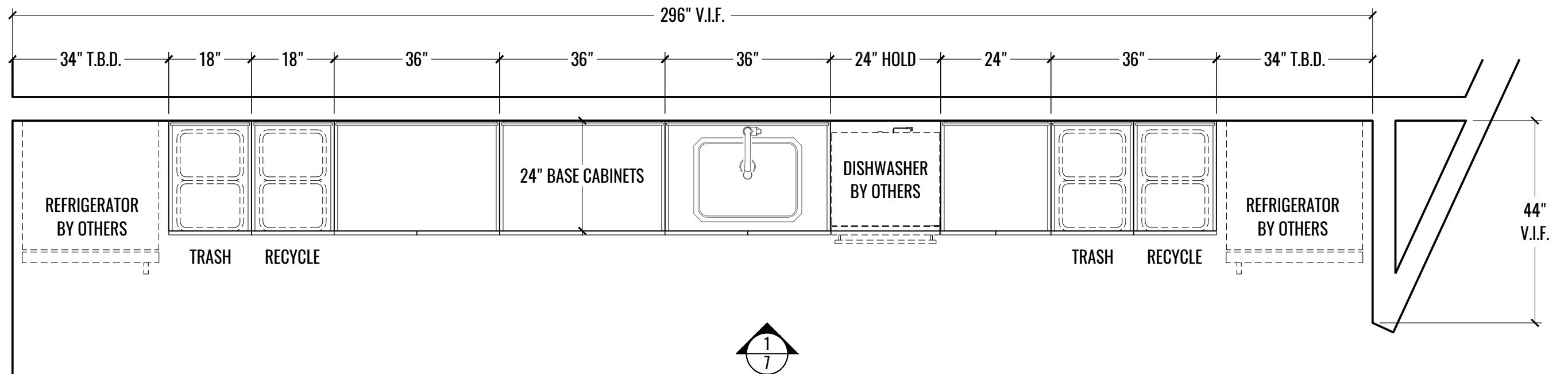

2 PLAN: KITCHENETTE 603 BASE CABINETS
6 SCALE: 1/2" = 1'-0"

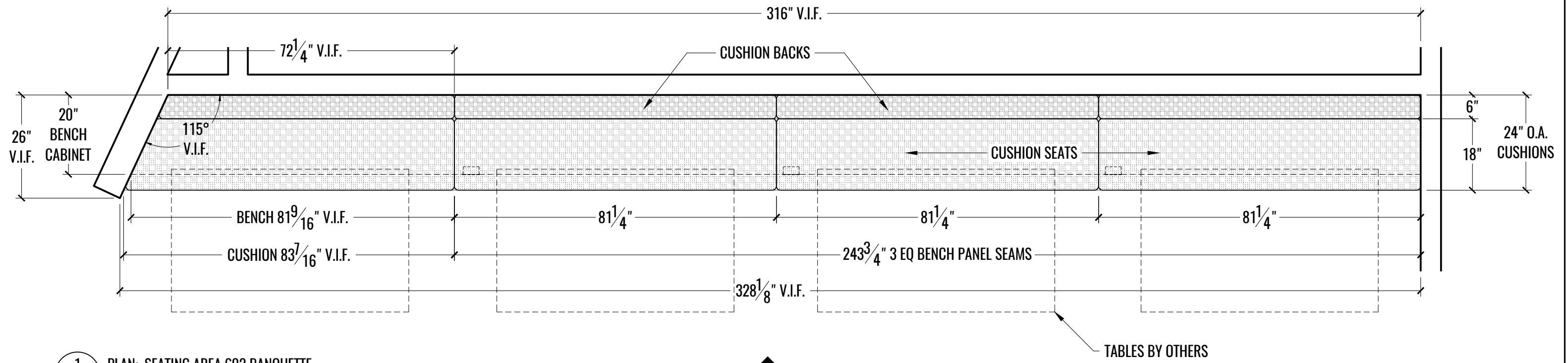

1 PLAN: SEATING AREA 602 BANQUETTE
8 SCALE: 1/2" = 1'-0"

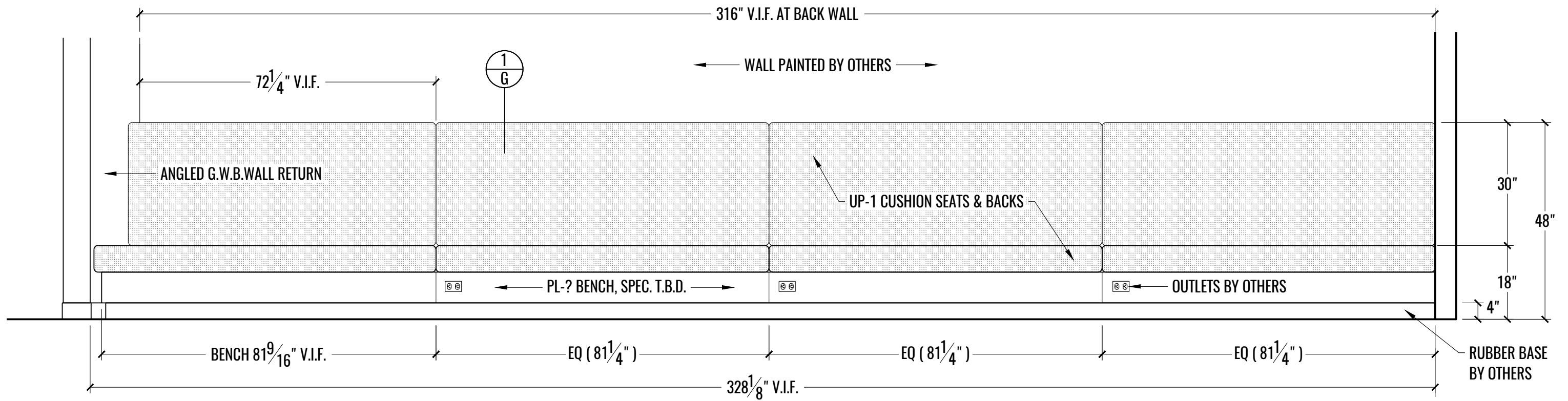
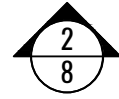

2 ELEVATION: SEATING AREA 602 BANQUETTE
8 SCALE: 1/2" = 1'-0"

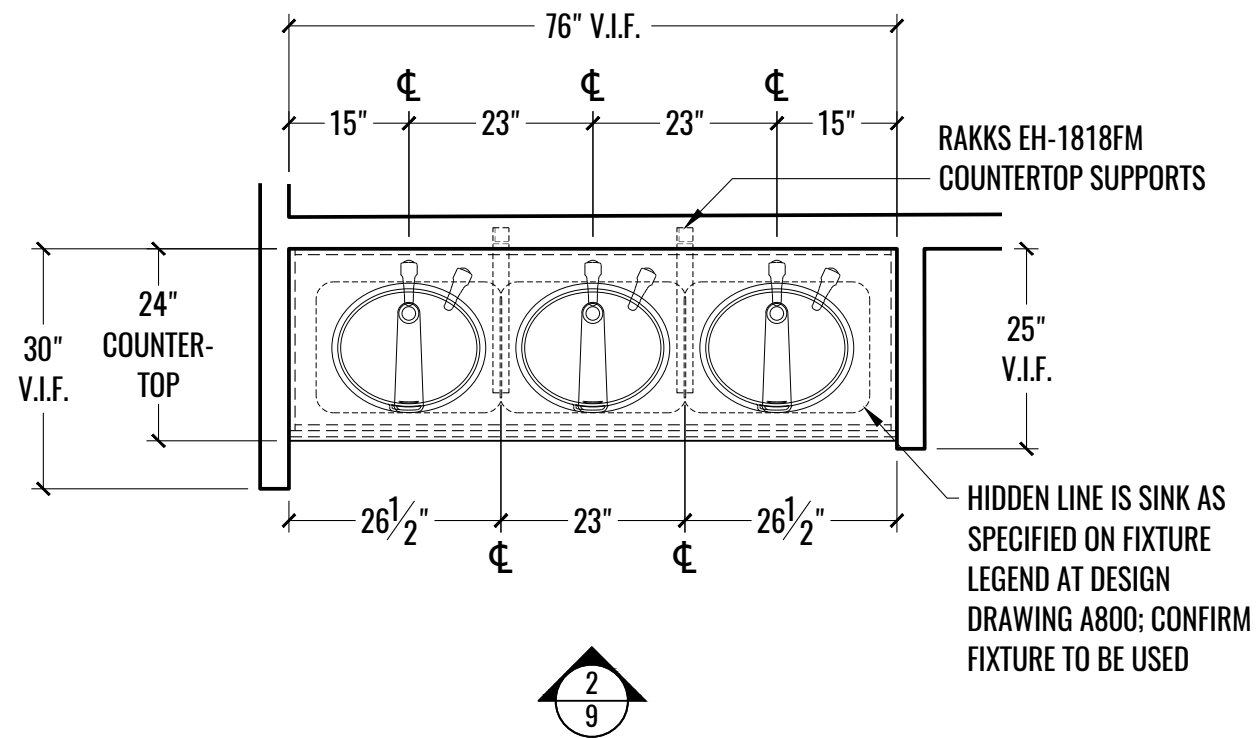

1 PLAN: MEN BB03 RESTROOM
9 SCALE: 1/2" = 1'-0"

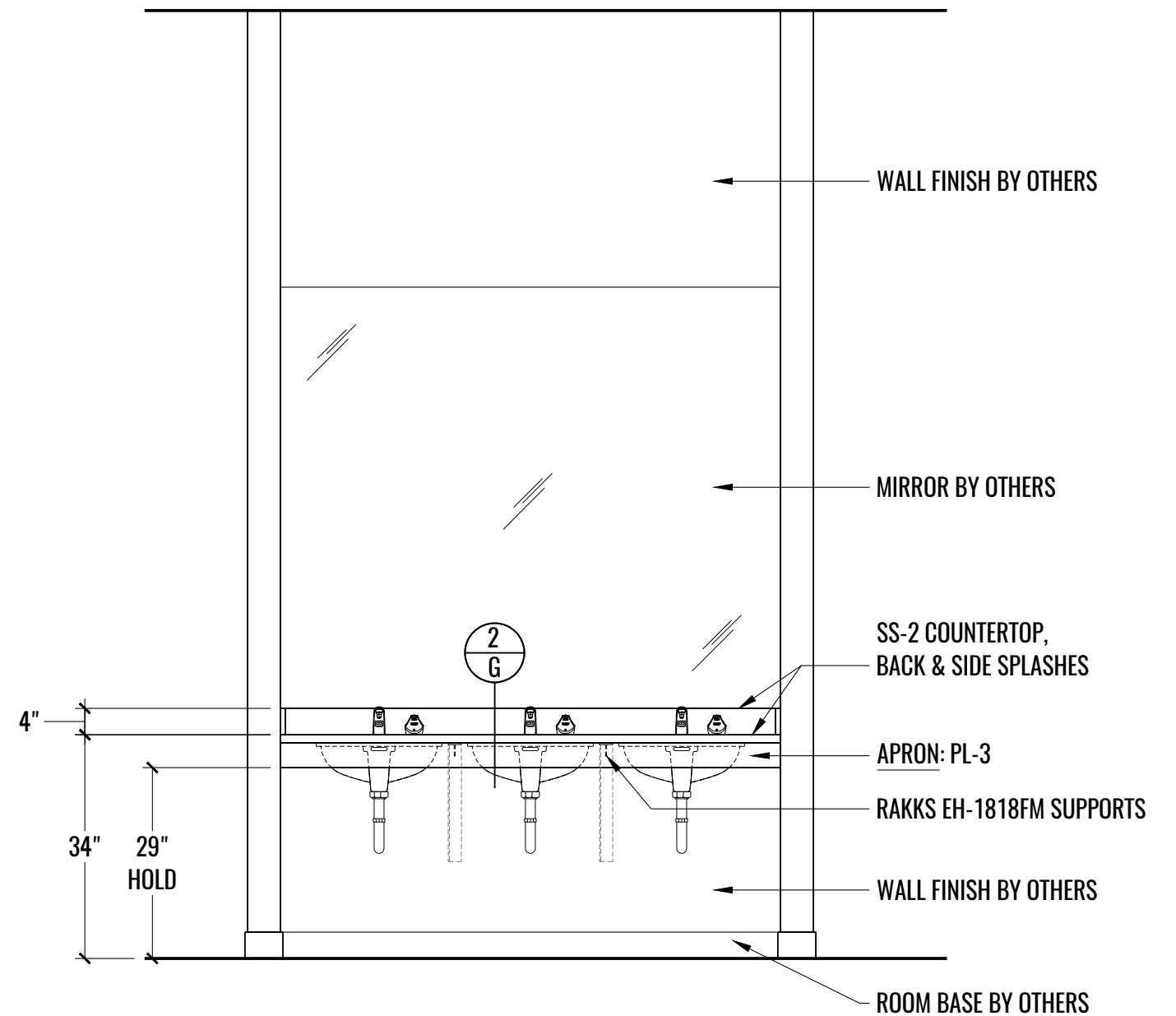

2 ELEVATION: MEN BB03 RESTROOM
9 SCALE: 1/2" = 1'-0"

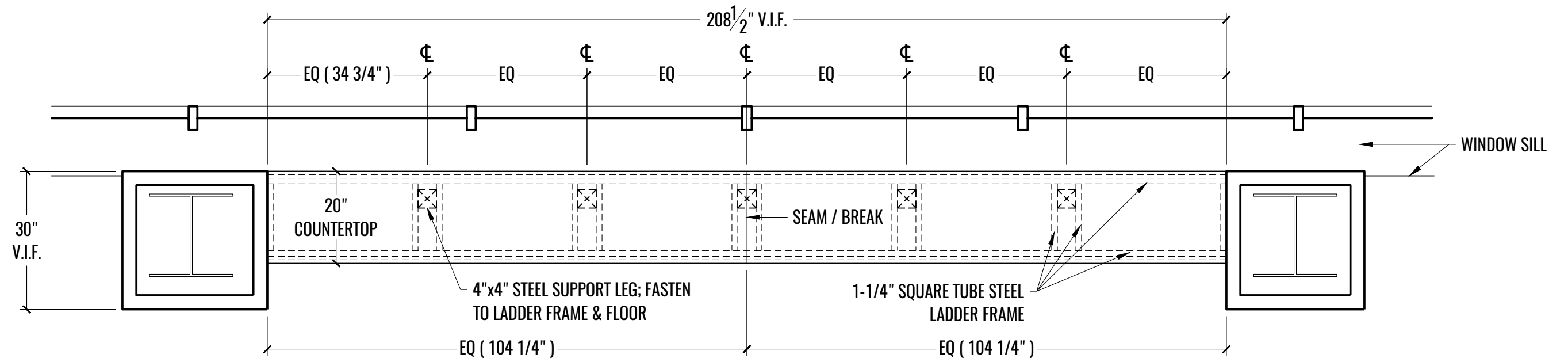

1 PLAN: MEETING AREA 630
11 SCALE: 1/2" = 1'-0"

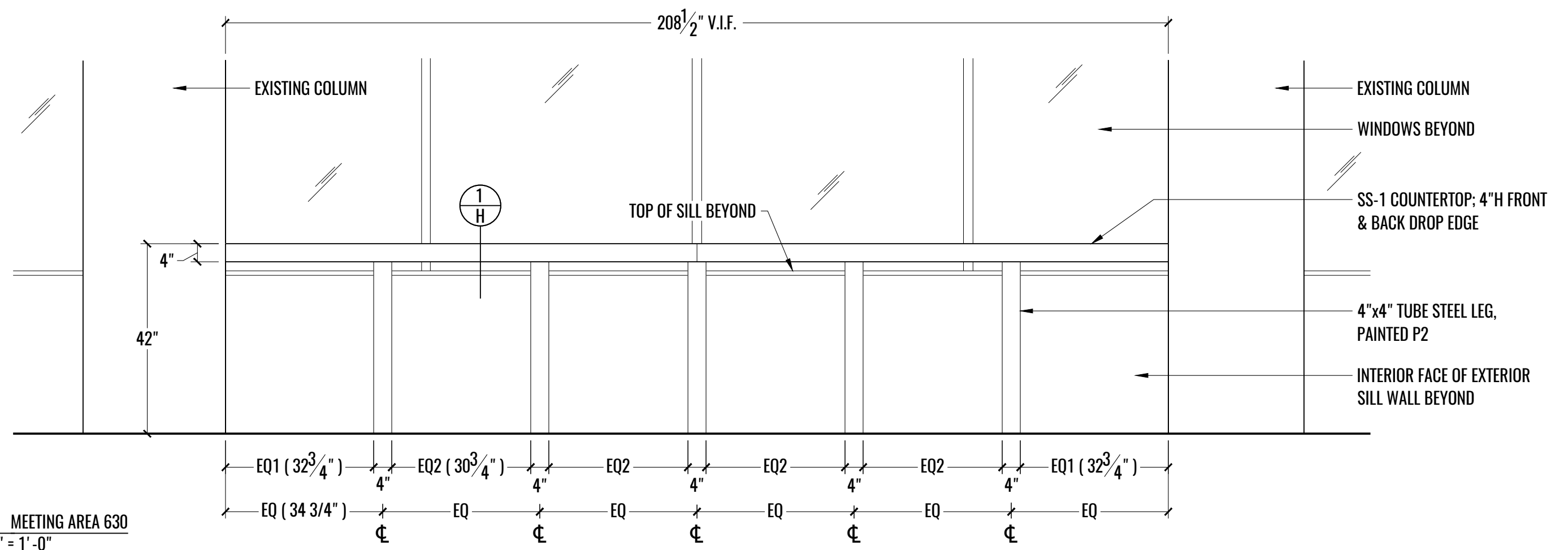
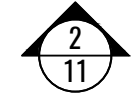

2 ELEVATION: MEETING AREA 630
11 SCALE: 1/2" = 1'-0"

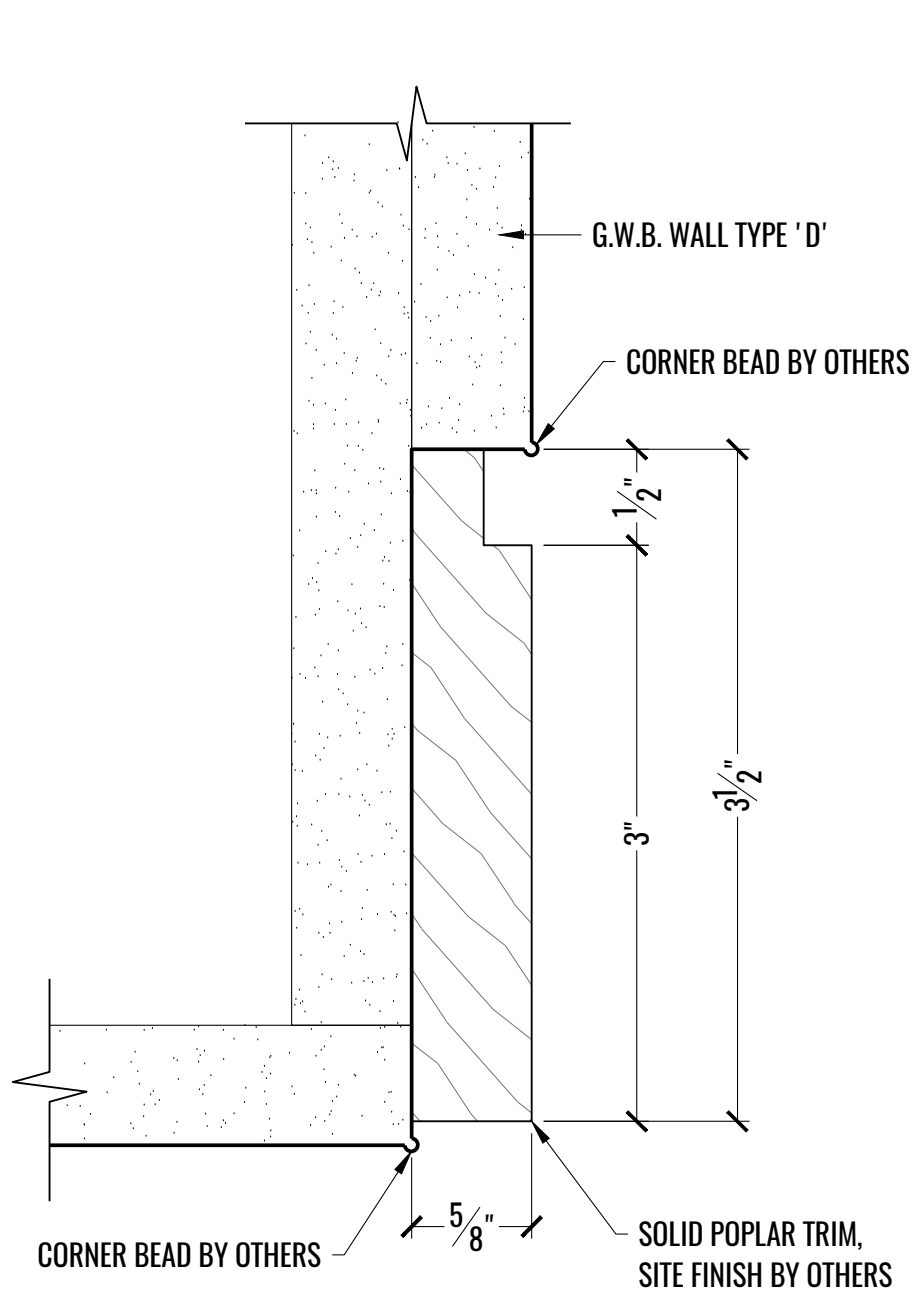

1
A
DETAIL: ELEVATOR LOBBY DOOR FRAME
SCALE: FULL

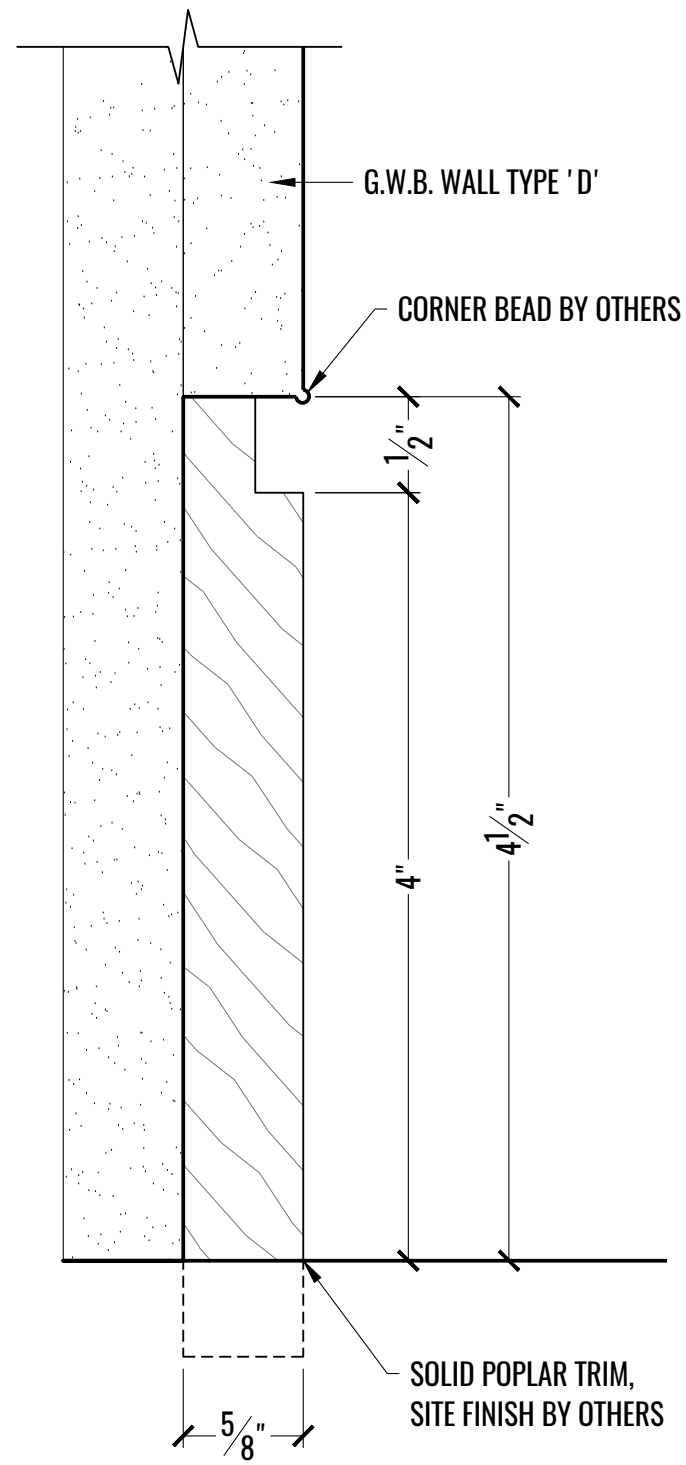

2
A
DETAIL: ELEVATOR LOBBY BASE
SCALE: FULL

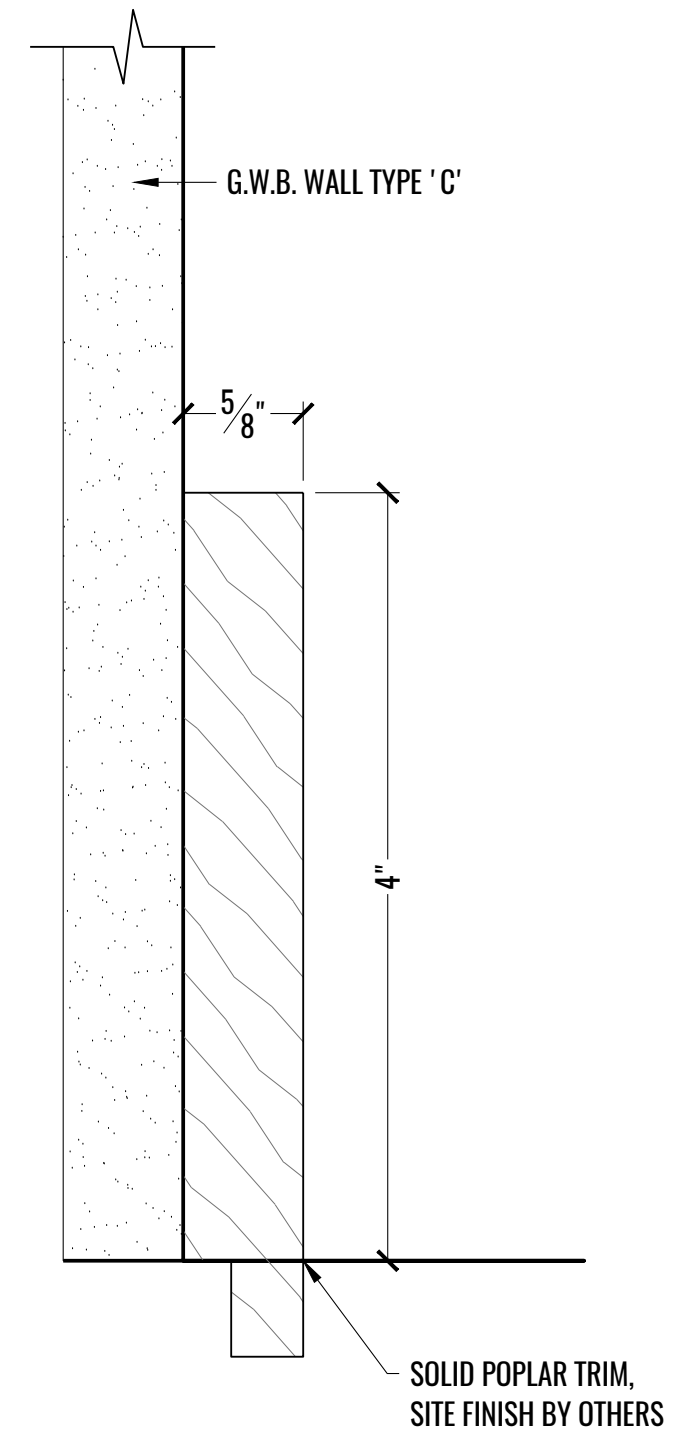

3
A
DETAIL: ELEVATOR LOBBY BASE AT COLUMNS
SCALE: FULL

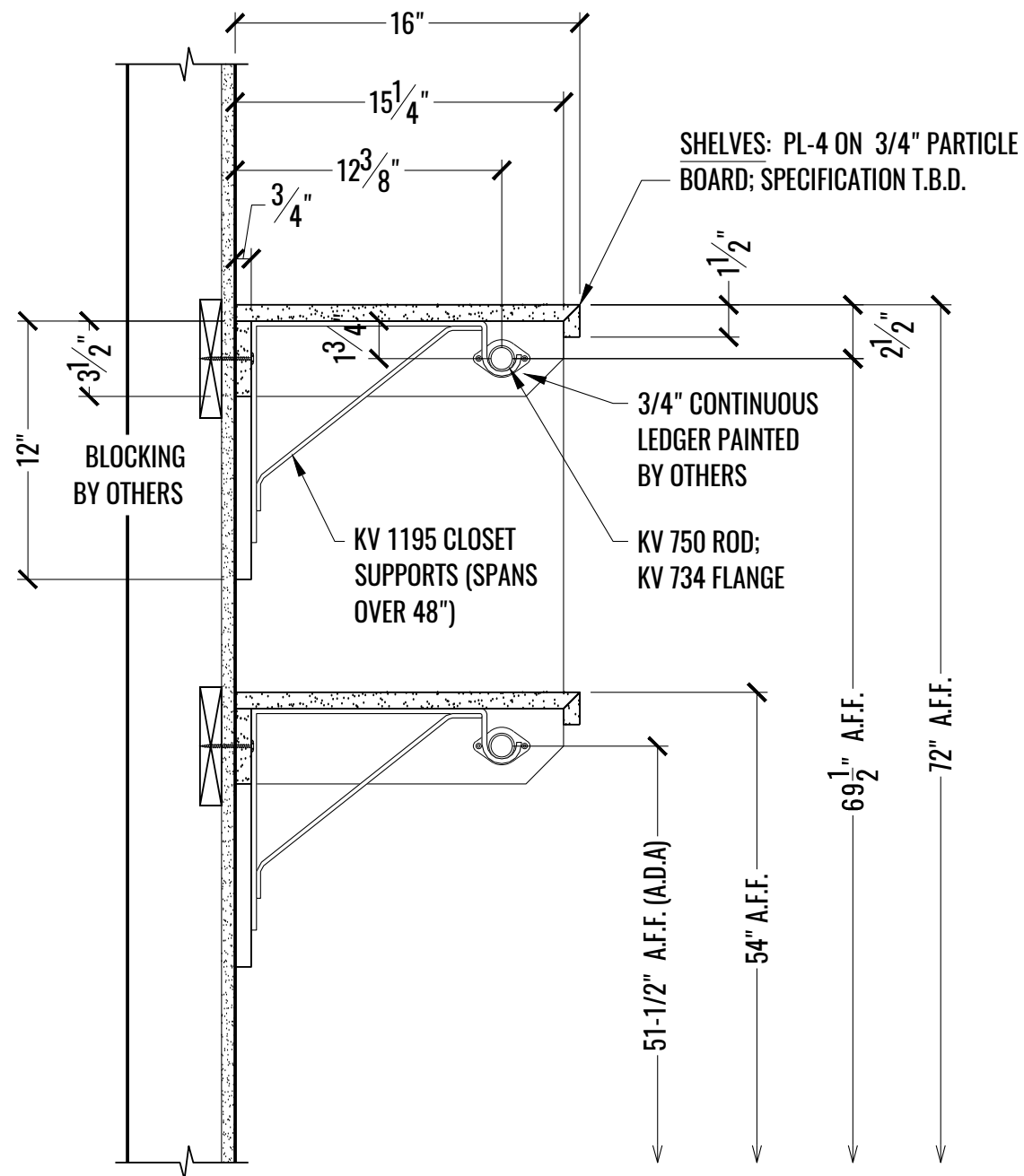

1 SECTION: COAT CLOSET 607
B SCALE: 1-1/2" = 1'-0"

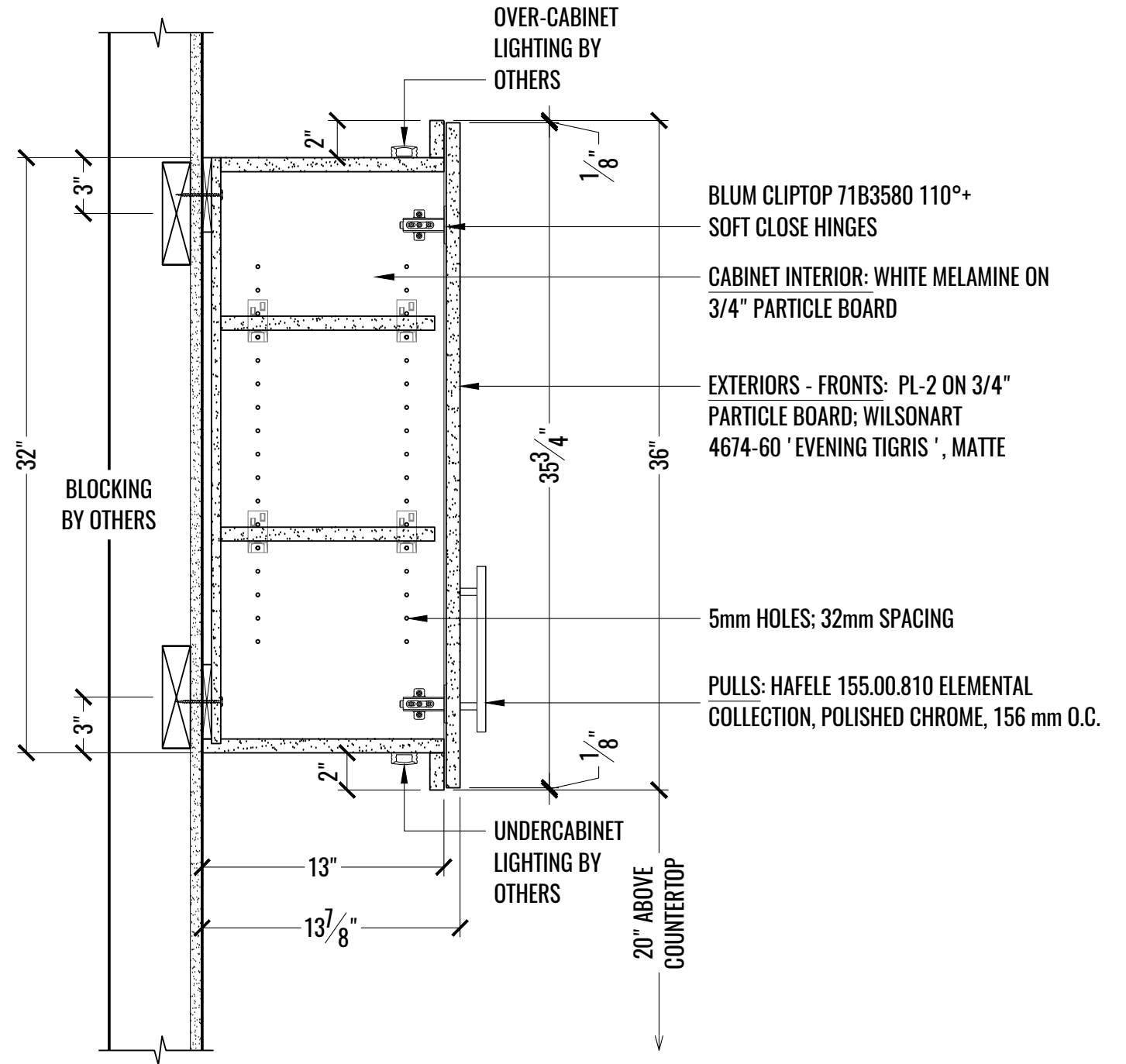

2 SECTION: COPY / PRINT 605 TYP. UPPER
B SCALE: 1-1/2" = 1'-0"

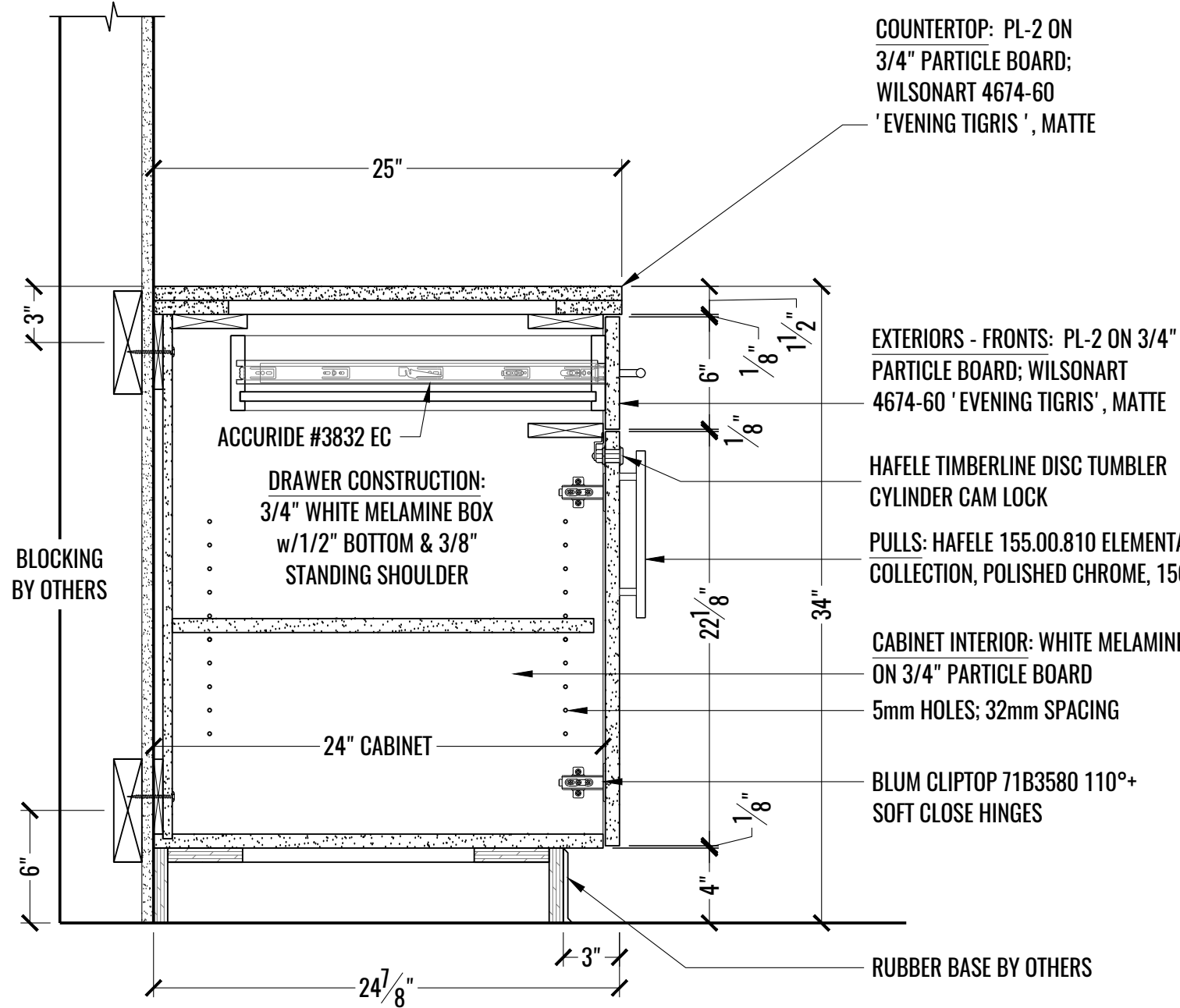

1 SECTION: COPY / PRINT 605 TYP. BASE CABINET
C SCALE: 1-1/2" = 1'-0"

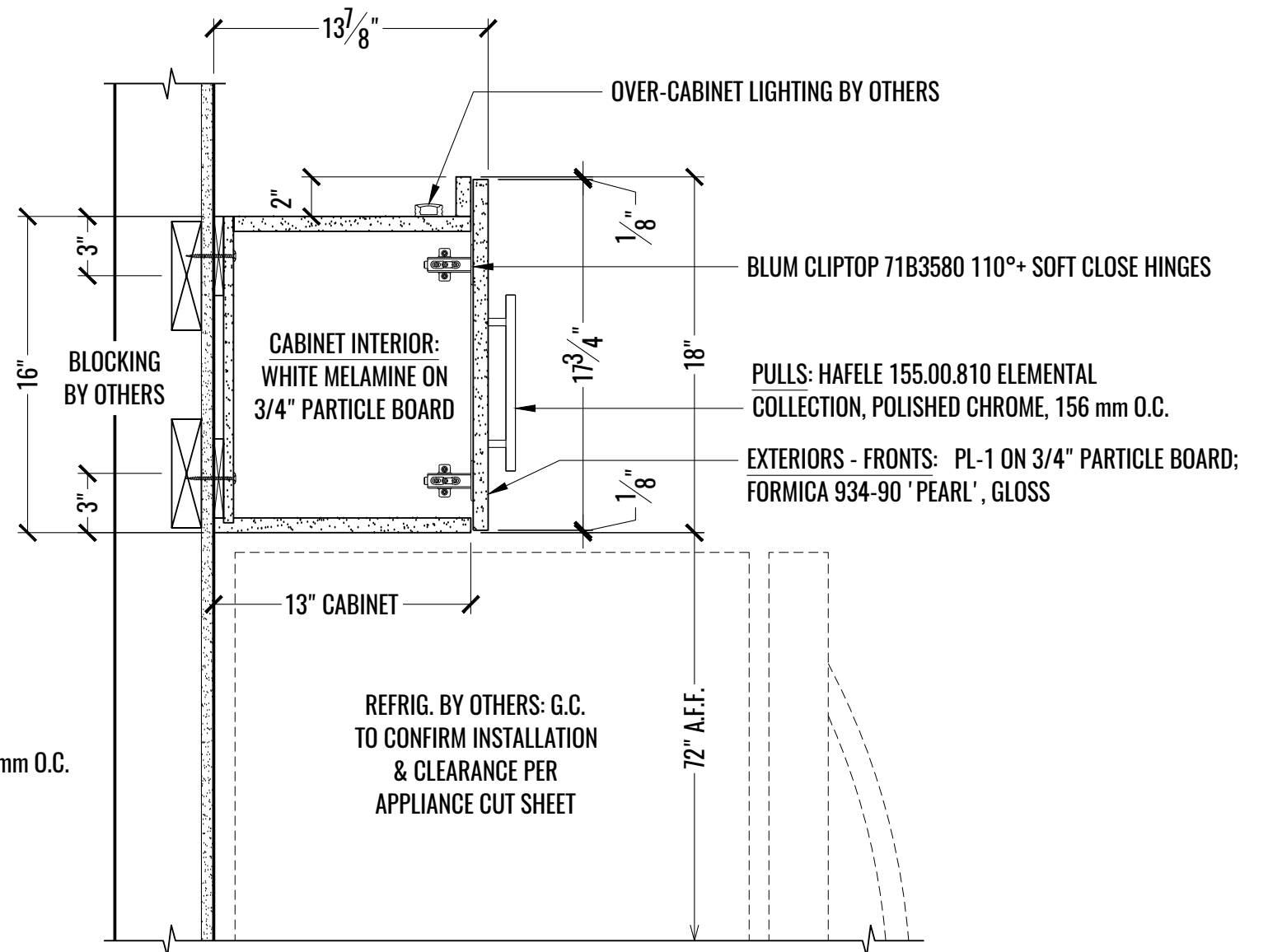

2 SECTION: KITCHENETTE 603 REFRIGERATOR UPPER
C SCALE: 1-1/2" = 1'-0"

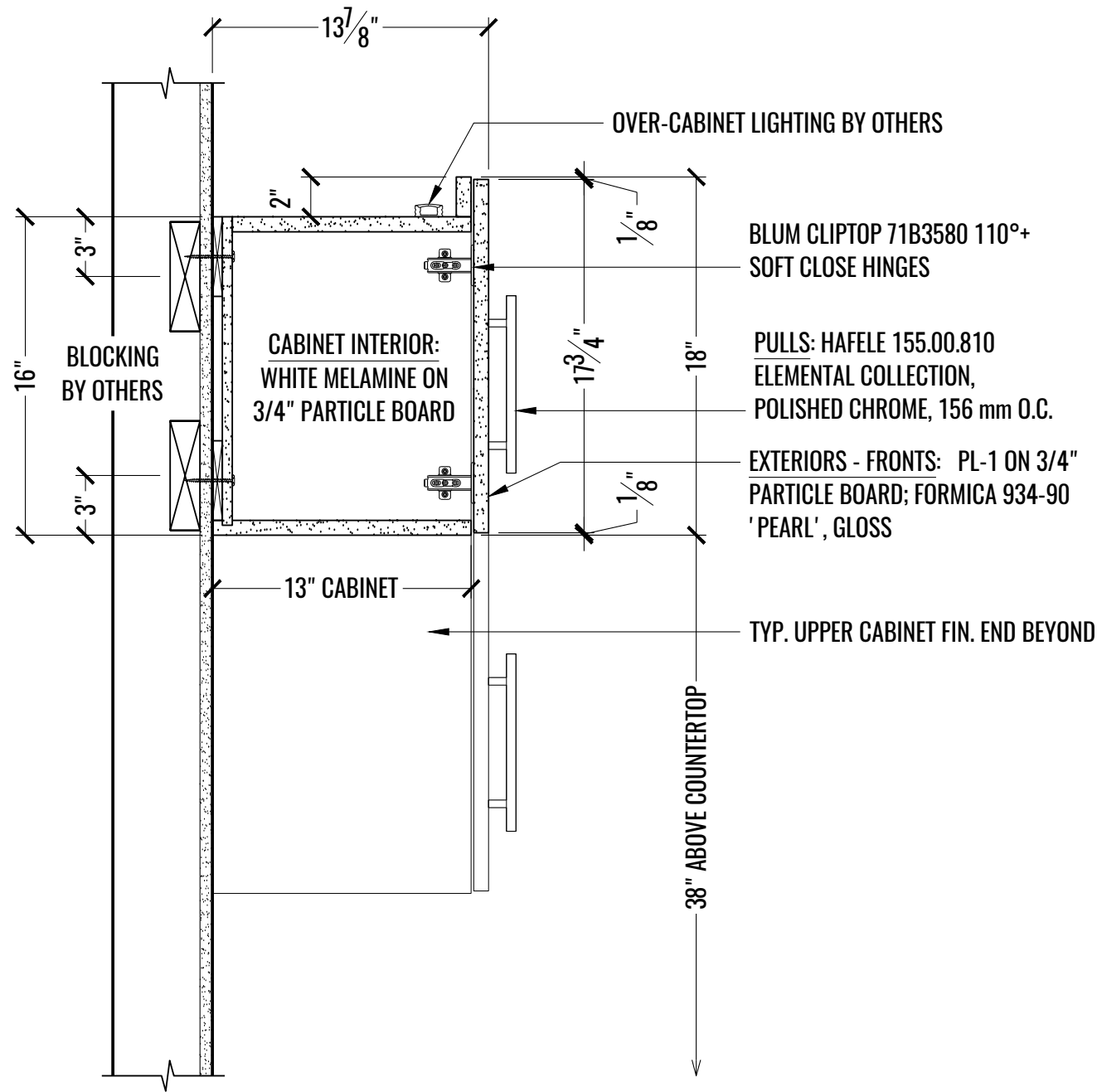

1 SECTION: KITCHENETTE 603 SINK UPPER CABINET
E SCALE: 1-1/2" = 1'-0"

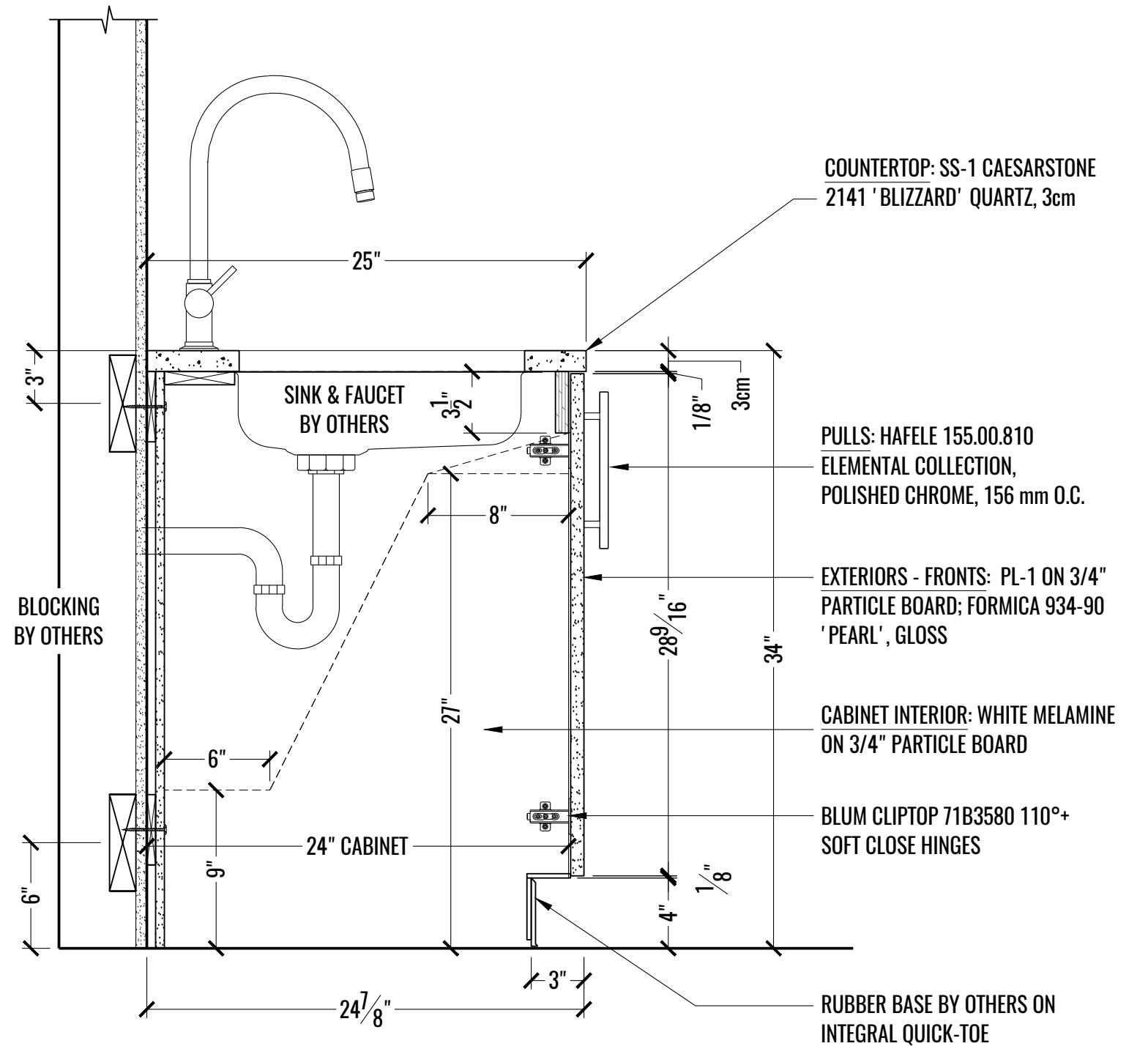

2 SECTION: KITCHENETTE 603 SINK BASE CABINET
E SCALE: 1-1/2" = 1'-0"

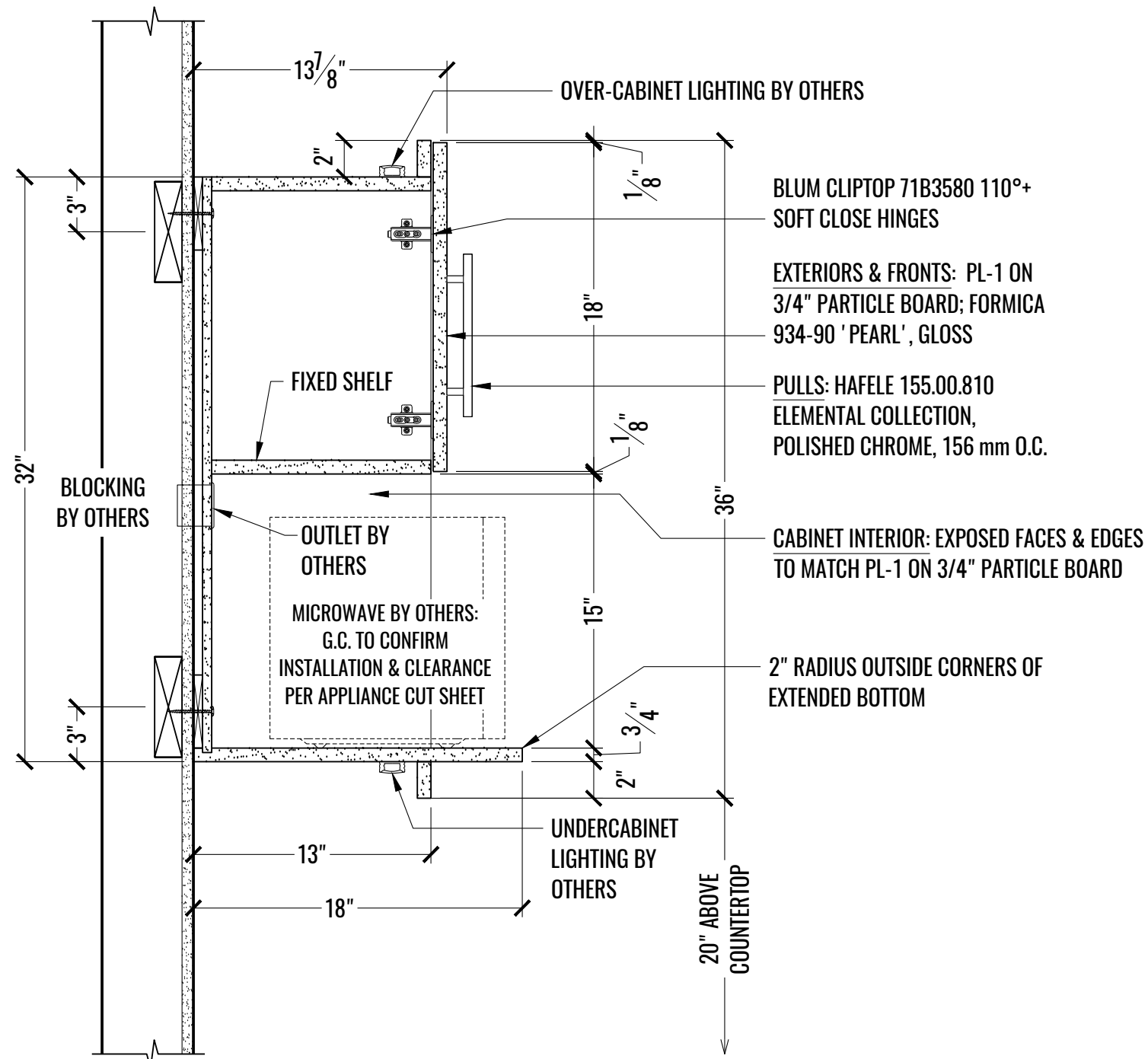

1 SECTION: KITCHENETTE 603 MICROWAVE UPPER CABINET
 F SCALE: 1-1/2" = 1'-0"

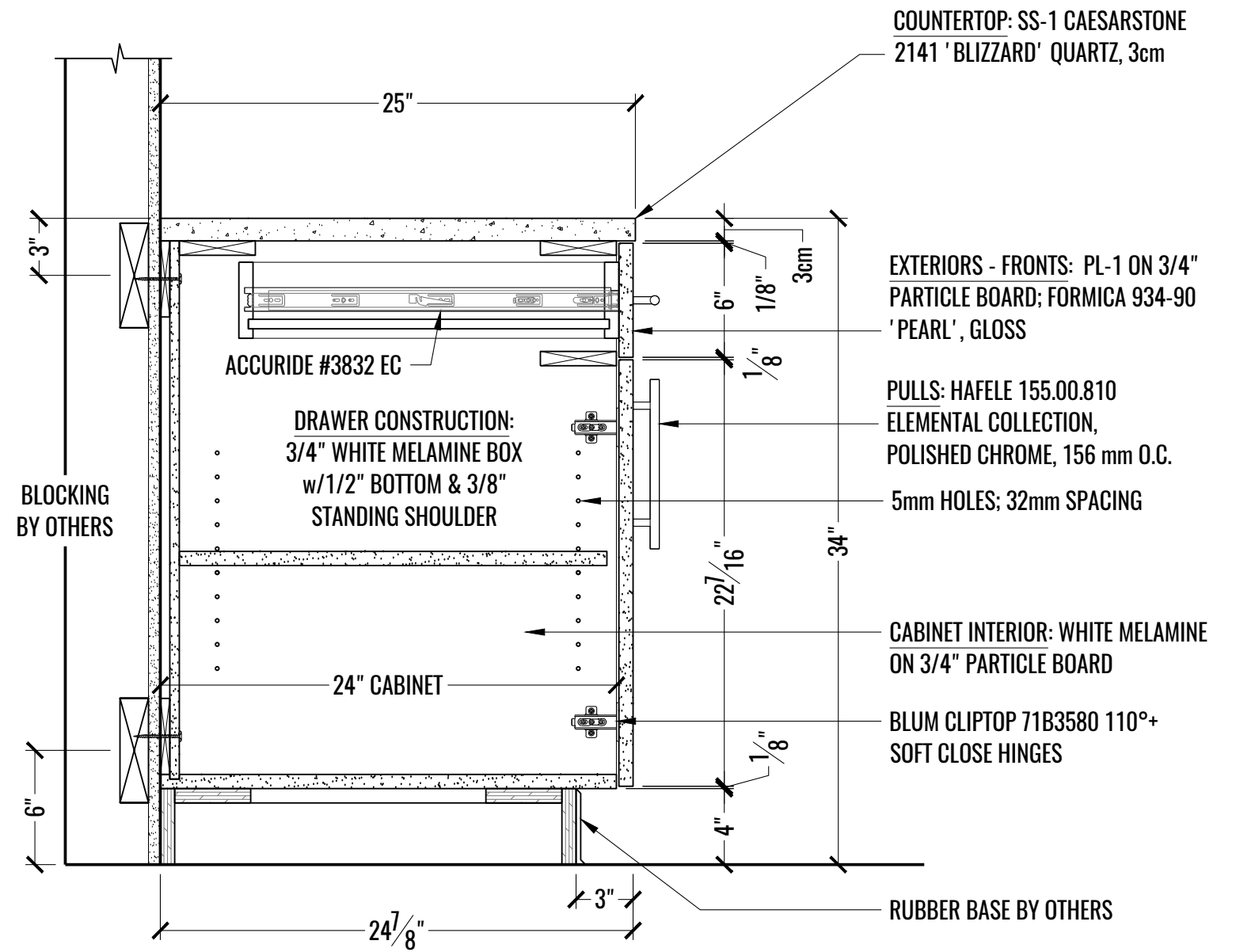

2 SECTION: KITCHENETTE 603 TYP. BASE CABINET
 F SCALE: 1-1/2" = 1'-0"

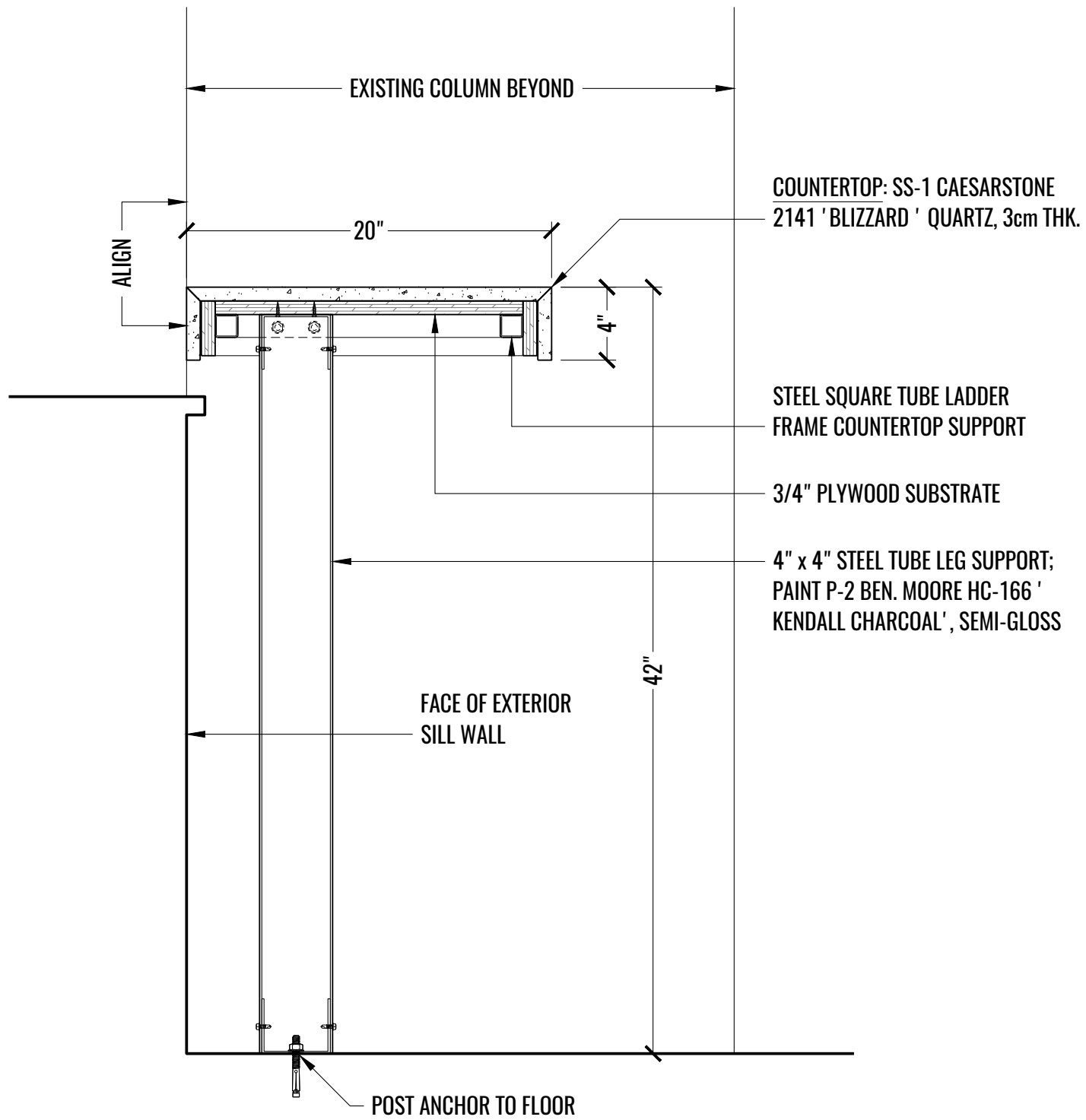

1 SECTION: MEETING AREA 630 COUNTERTOP
H SCALE: 1-1/2" = 1'-0"