

1 PLAN: PROJECT SCOPE - EIGHTEENTH FLOOR
1 SCALE: NOT TO SCALE

— 3/4" THK X 4"H PAINT GRADE MDF BASE (WB-1) -
SQUARE EDGE FLAT PROFILE SURFACE MOUNT, MITER
ALL CORNERS. TAKEOFF TOTALS = 440LF +/-

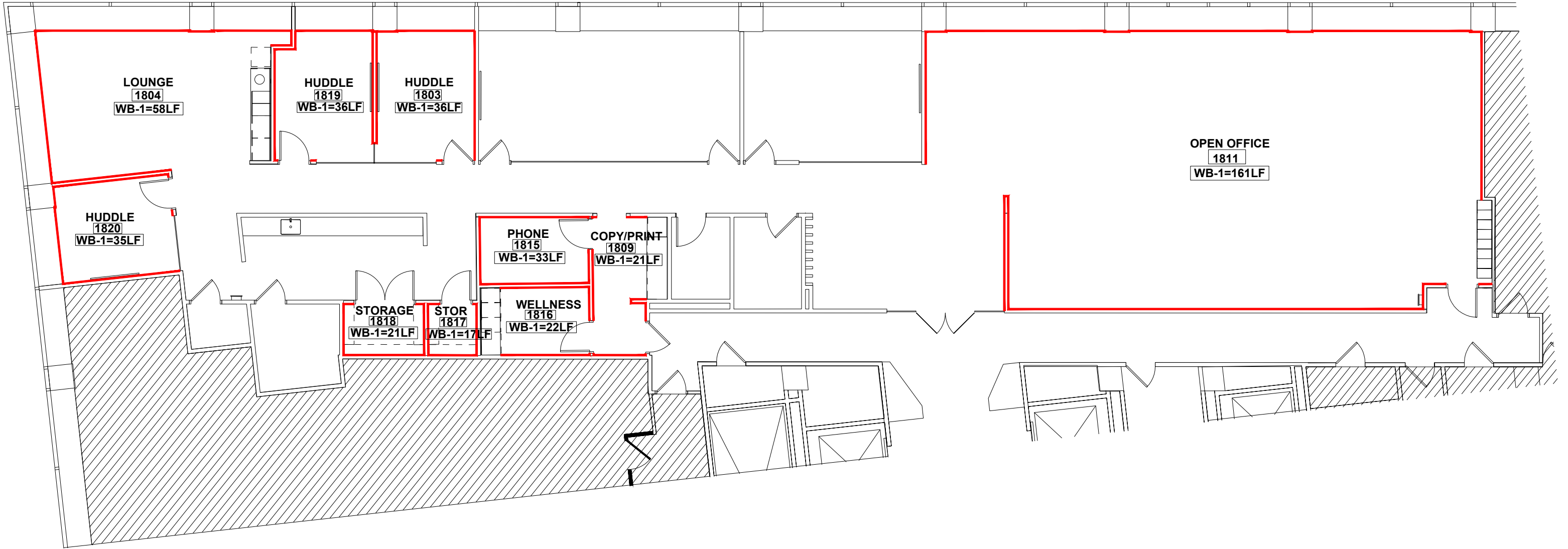

1 PLAN: PROJECT SCOPE - WOOD BASE SCOPE
2 SCALE: NOT TO SCALE

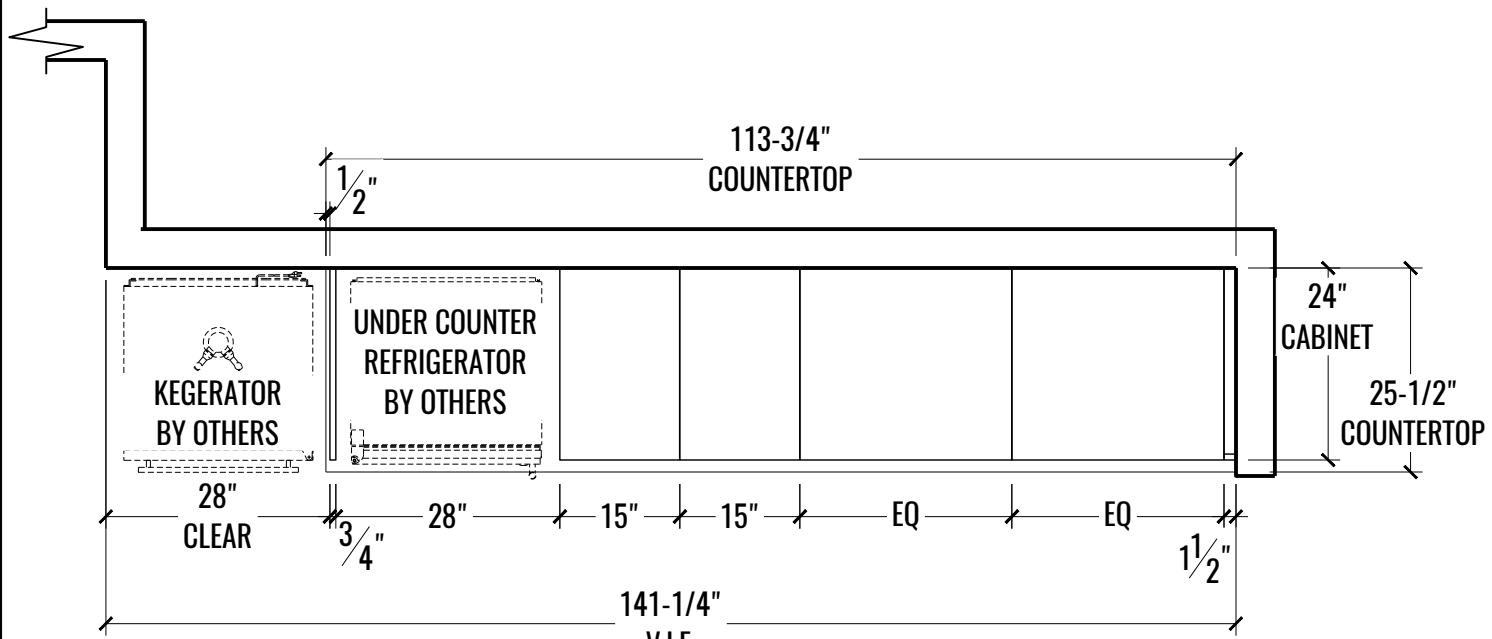

1 PLAN: LOUNGE RM# 1804
3 SCALE: 1/2" = 1'-0"

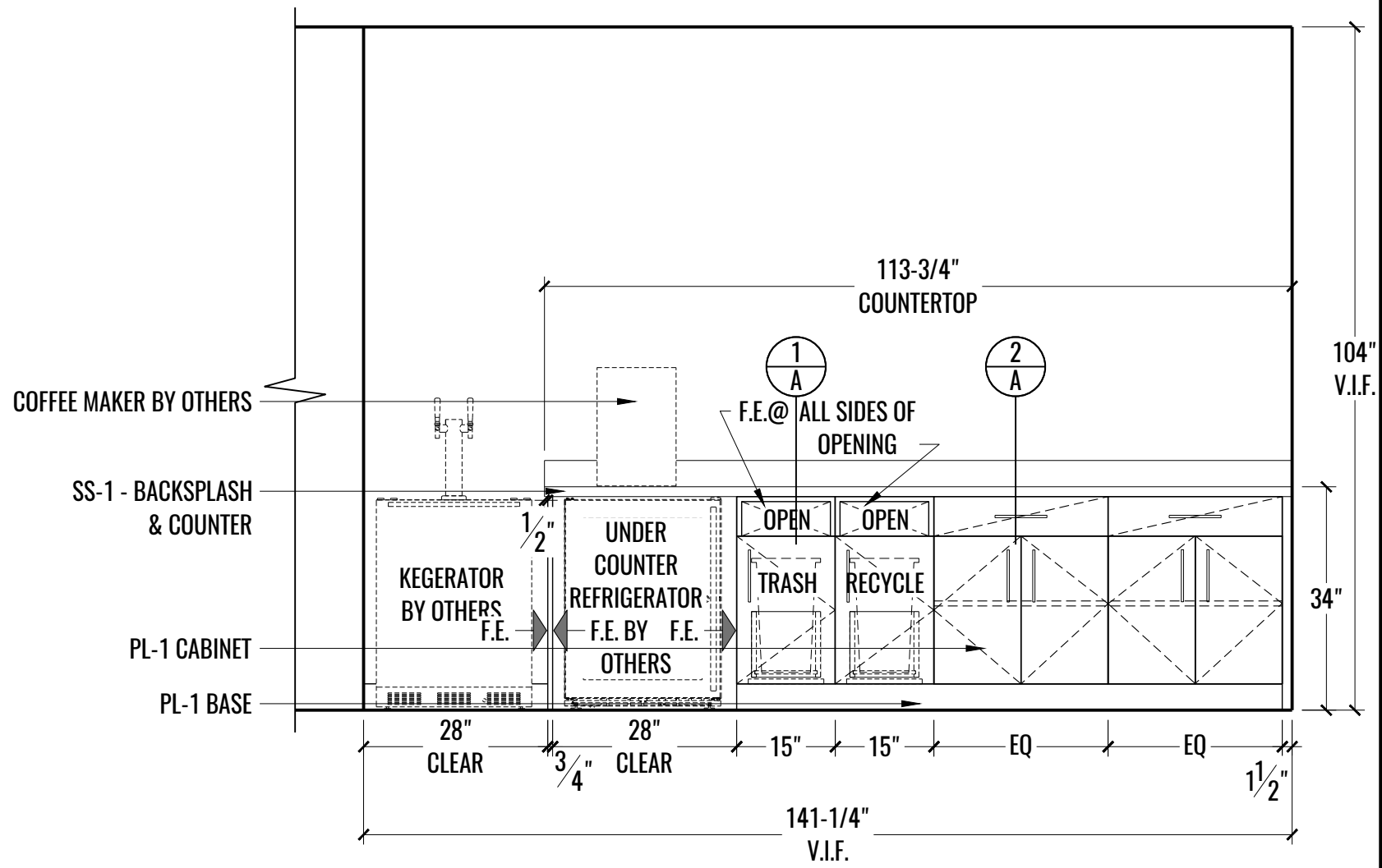

2 ELEVATION: LOUNGE RM# 1804
3 SCALE: 1/2" = 1'-0"

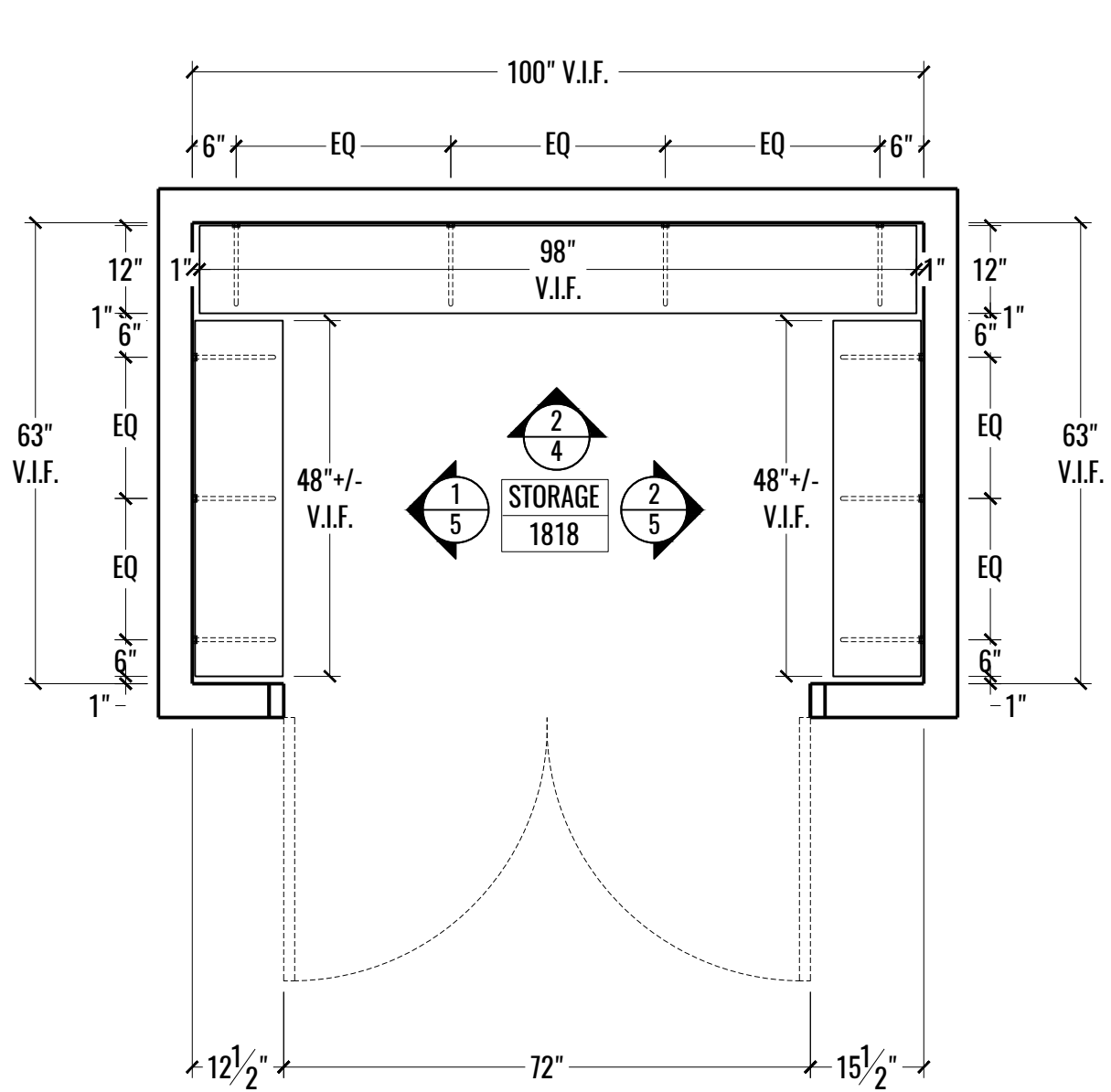

1 PLAN: STORAGE RM# 1818
4 SCALE: 1/2" = 1'-0"

PL-1 SHELVES
(ALL EDGES SHALL BE FINISHED)

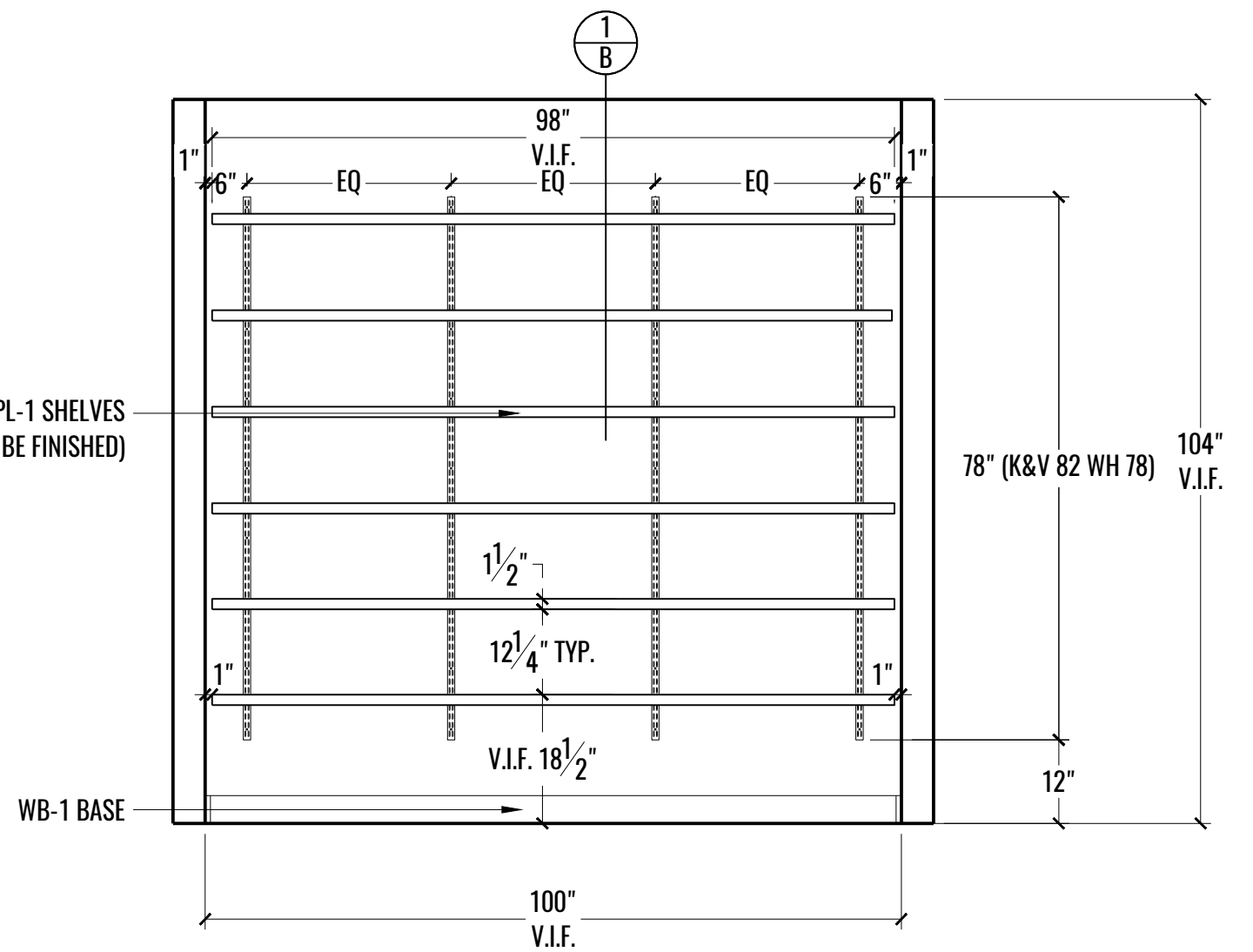

2 ELEVATION: STORAGE RM# 1818
4 SCALE: 1/2" = 1'-0"

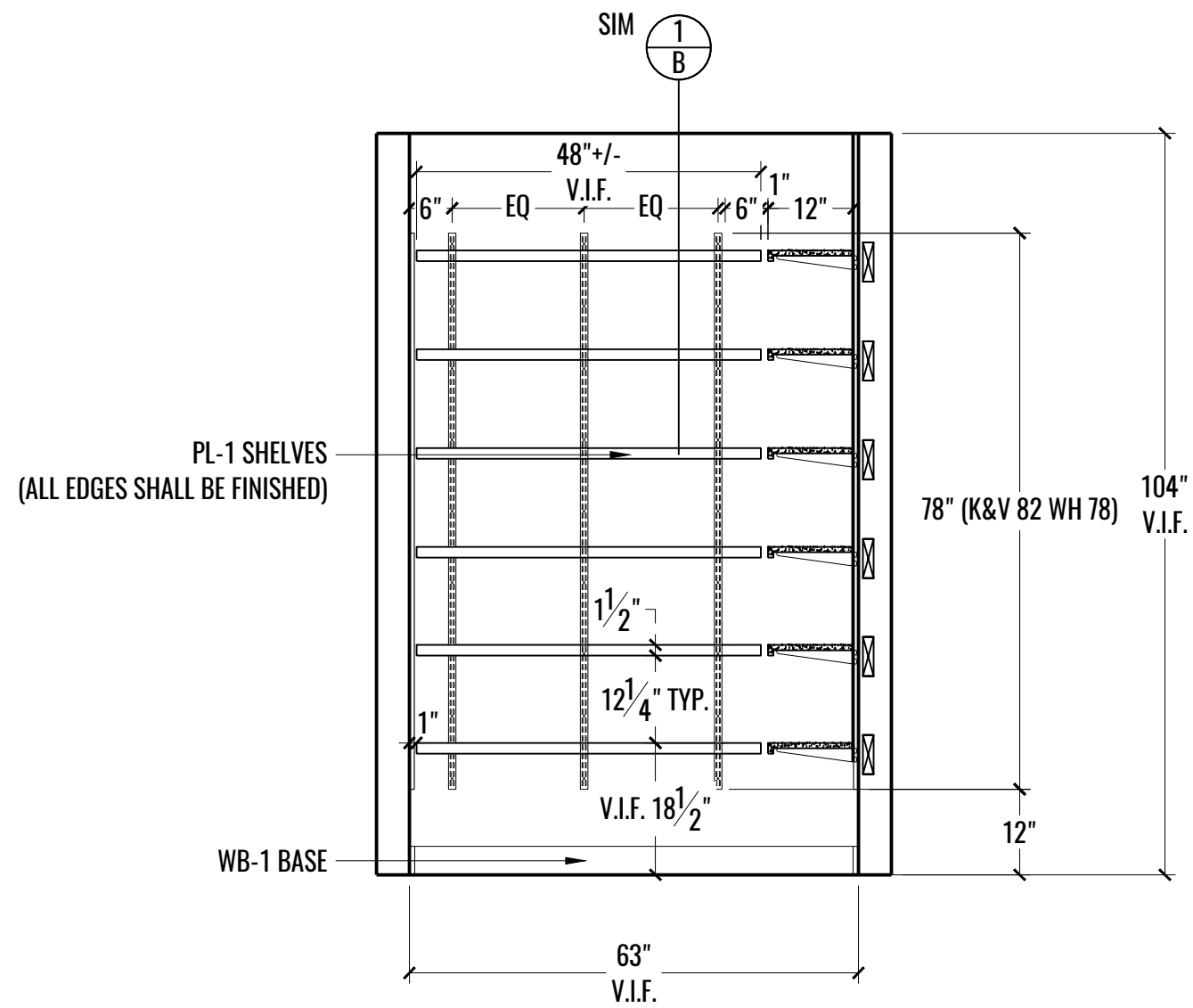

1 ELEVATION: STORAGE RM# 1818 (LEFT)
5 SCALE: 1/2" = 1'-0"

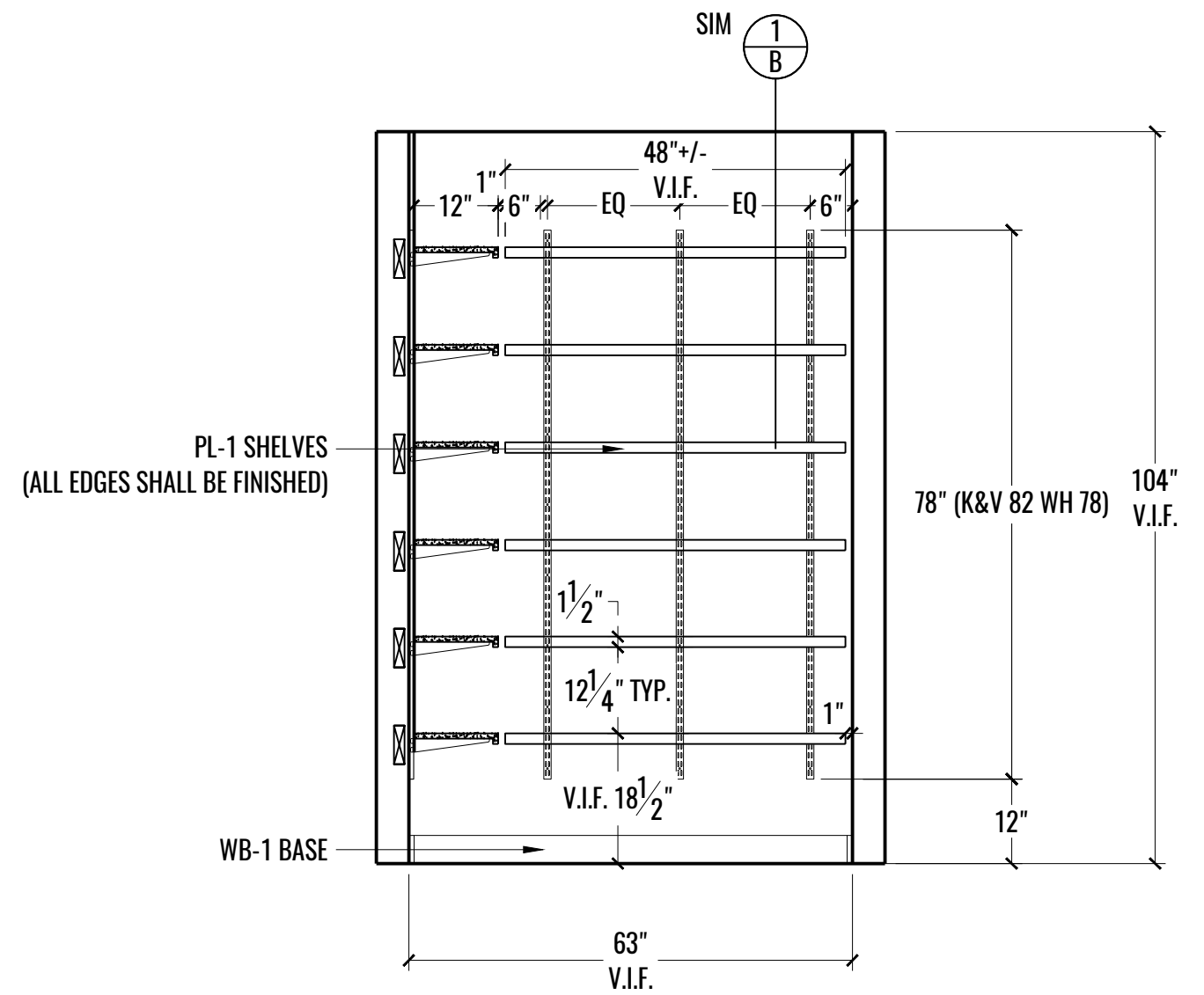

2 ELEVATION: STORAGE RM# 1818 (RIGHT)
5 SCALE: 1/2" = 1'-0"

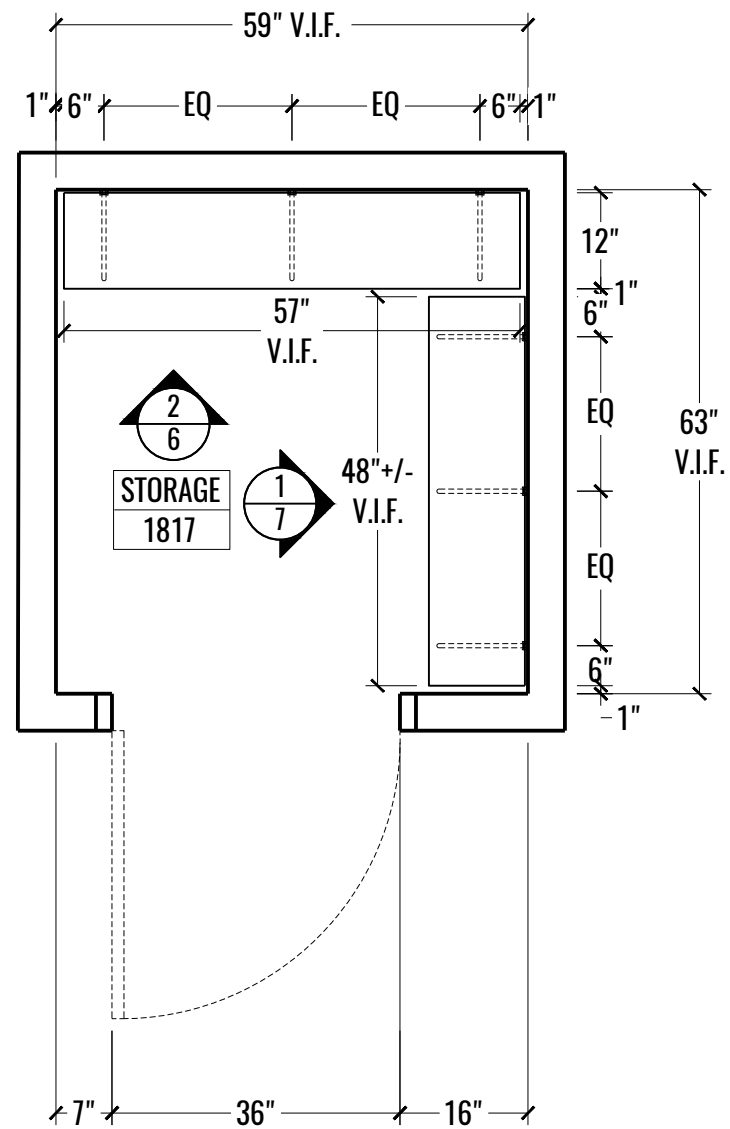

1 PLAN: STORAGE RM# 1817
6 SCALE: 1/2" = 1'-0"

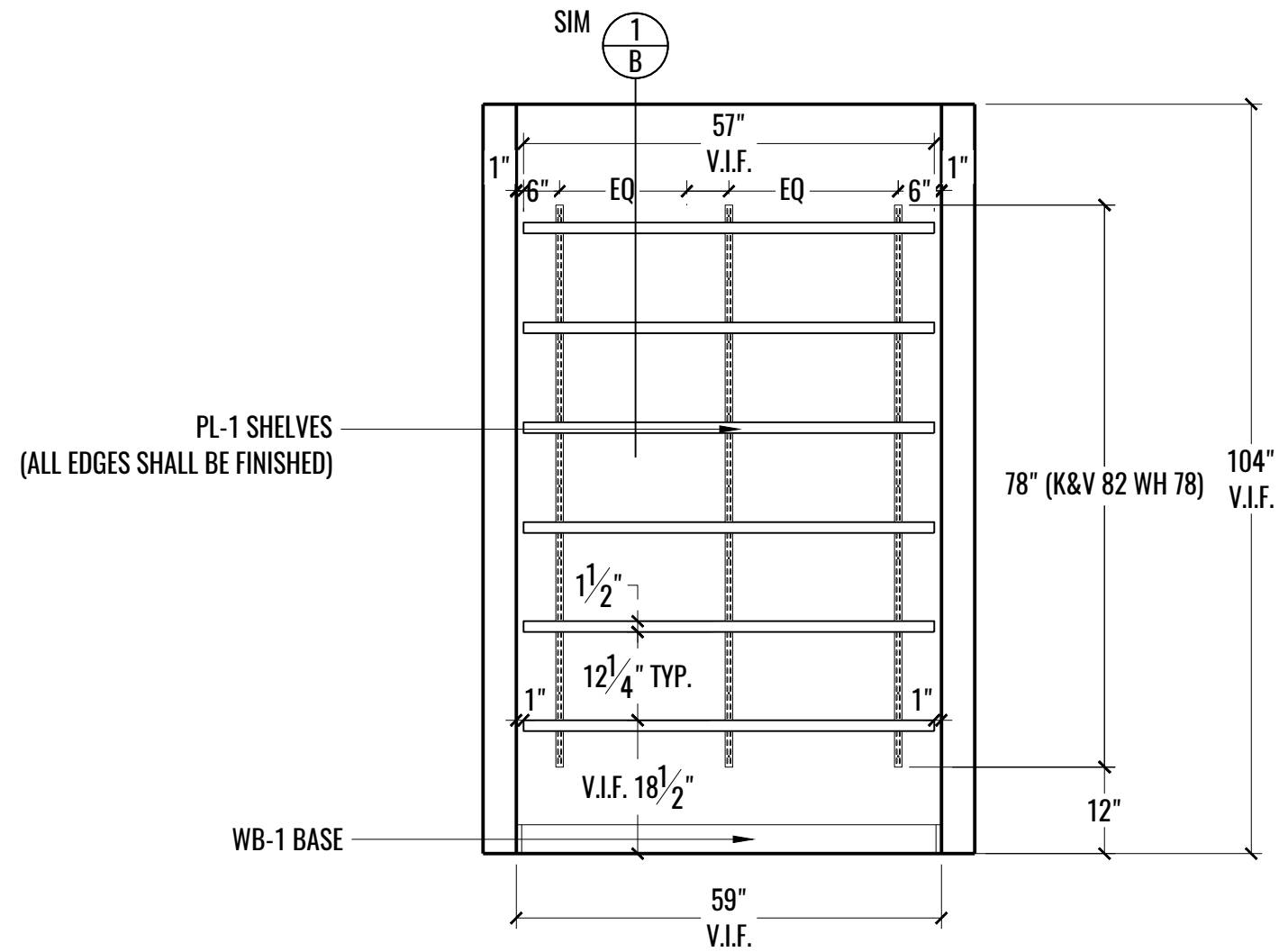

2 ELEVATION: STORAGE RM# 1817
6 SCALE: 1/2" = 1'-0"

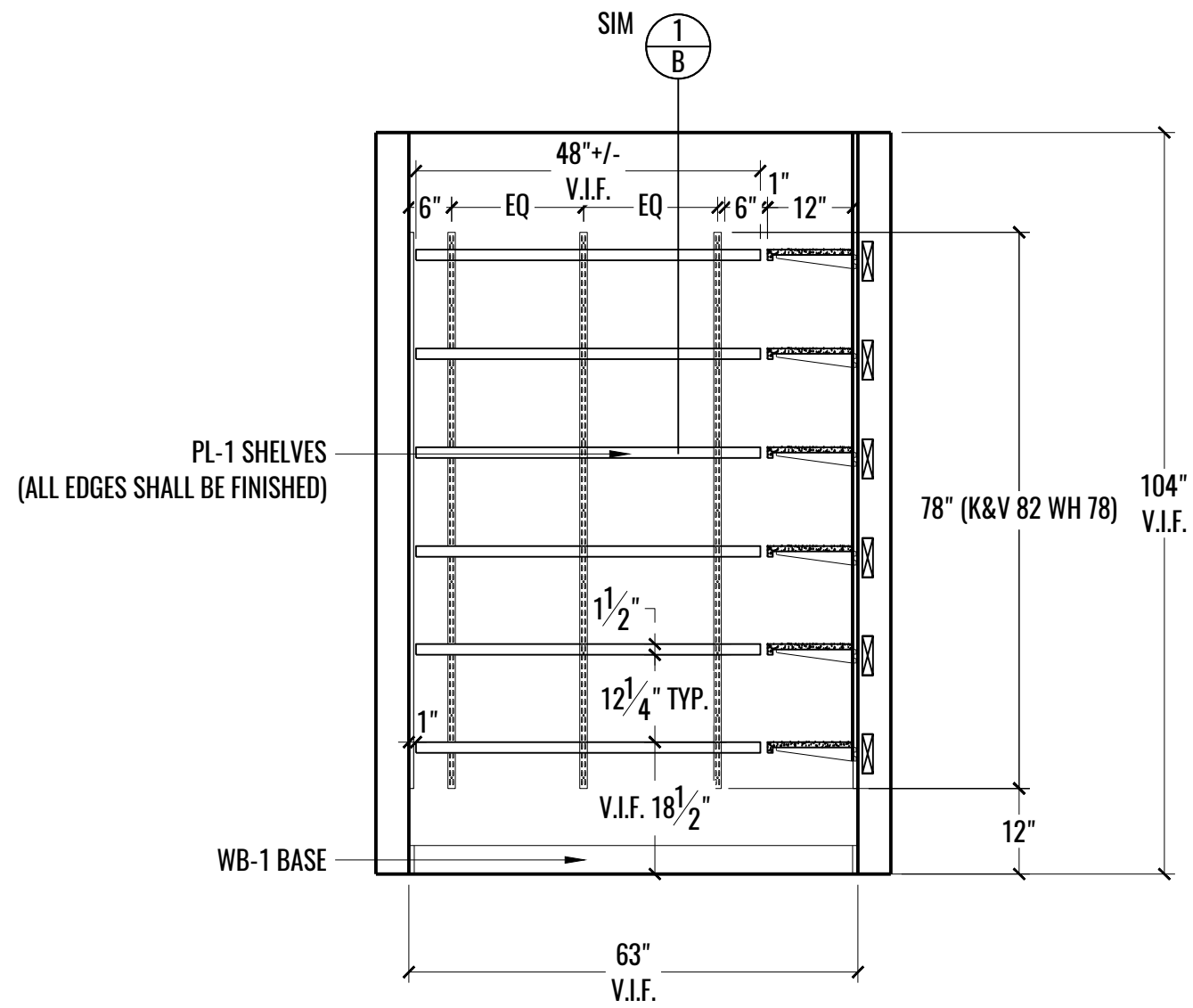

1
7 ELEVATION: STORAGE RM# 1817 (RIGHT)
SCALE: 1/2" = 1'-0"

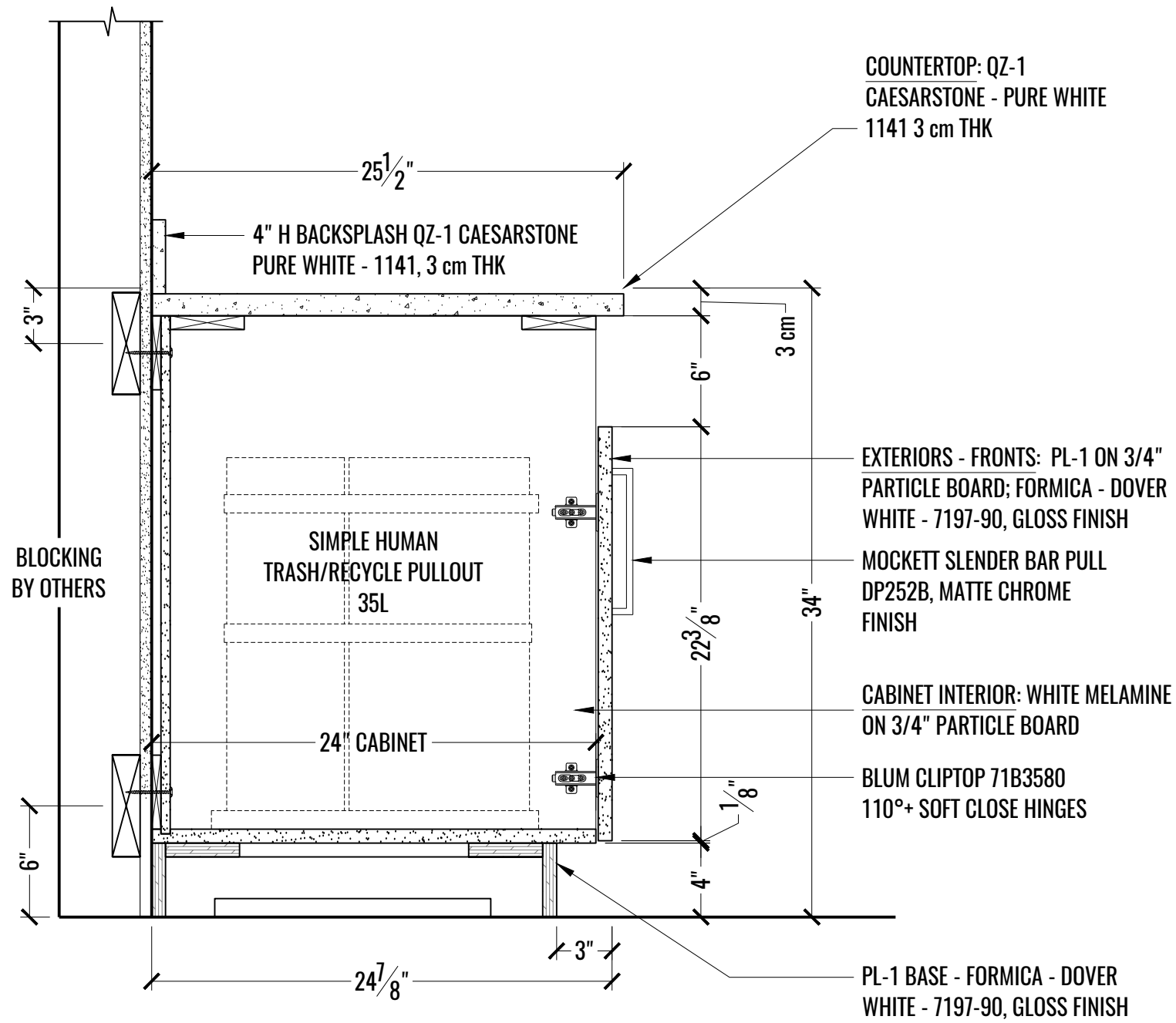

1 SECTION: LOUNGE RM# 1804 - TRASH/RECYCLE PULLOUT
A SCALE: 1-1/2" = 1'-0"

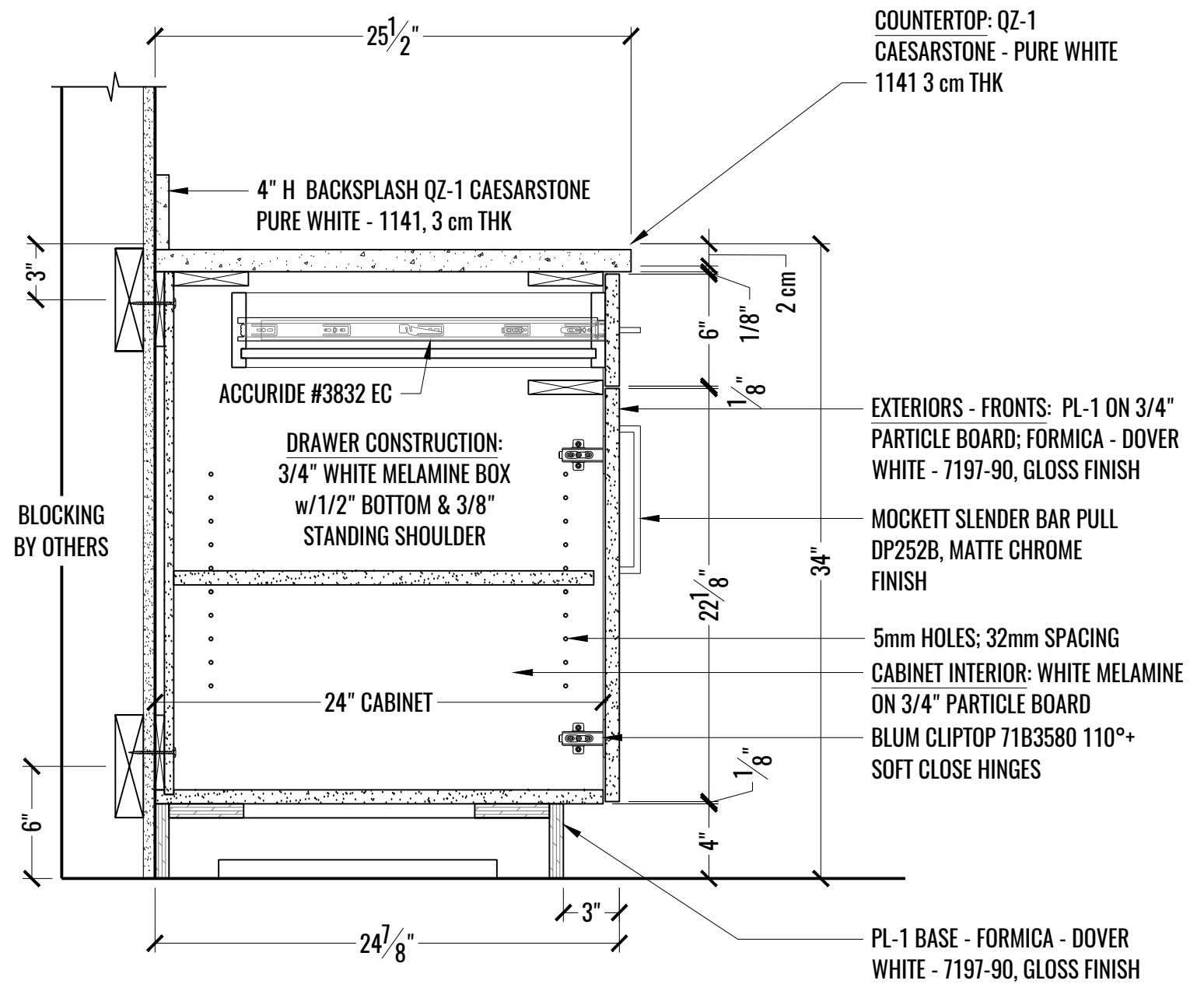

2 SECTION: LOUNGE RM# 1804 - BASE CABINET W/DRAWER
A SCALE: 1-1/2" = 1'-0"

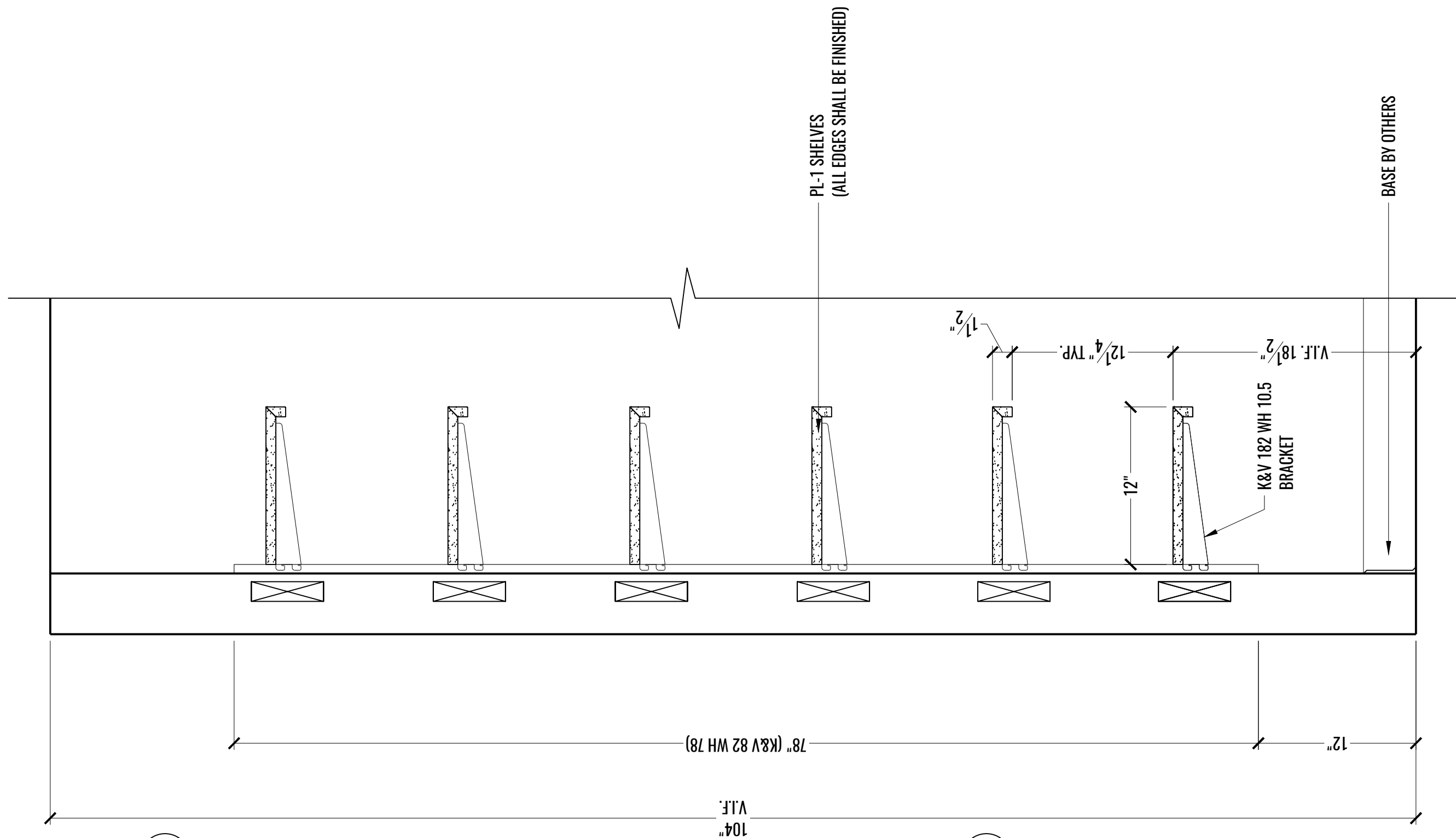

1 SECTION: DESCRIPTION
B SCALE: 1-1/2" = 1'-0"

2 SECTION: DESCRIPTION
B SCALE: 1-1/2" = 1'-0"

1 SECTION: STORAGE RMS# S 1817 & 1818 - SHELVING
B SCALE: 1-1/2" = 1'-0"