

1 PLAN: PROJECT SCOPE - KITCHEN LEVEL THREE  
 1 SCALE: NOT TO SCALE

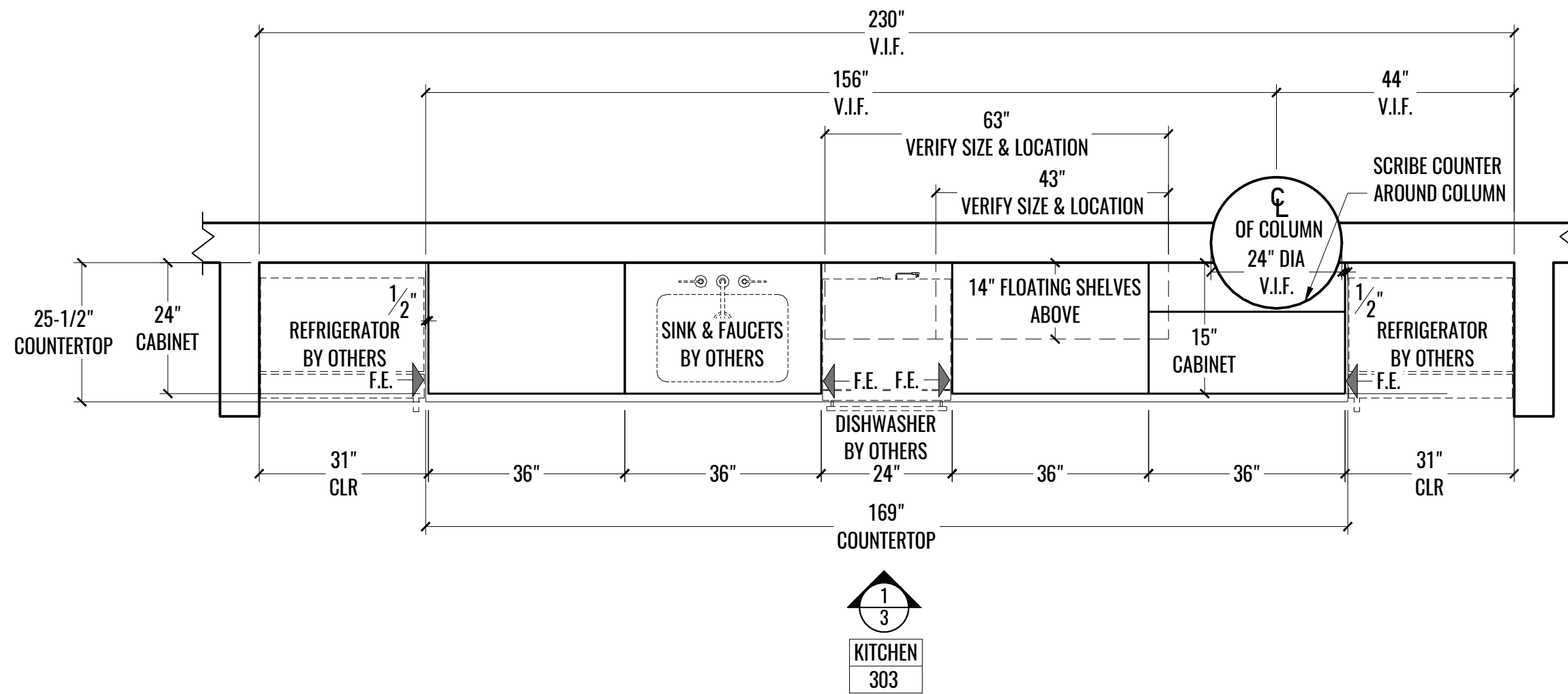

1 PLAN: KITCHEN RM# 303 - @ WALL  
 2 SCALE: 1/2" = 1'-0"

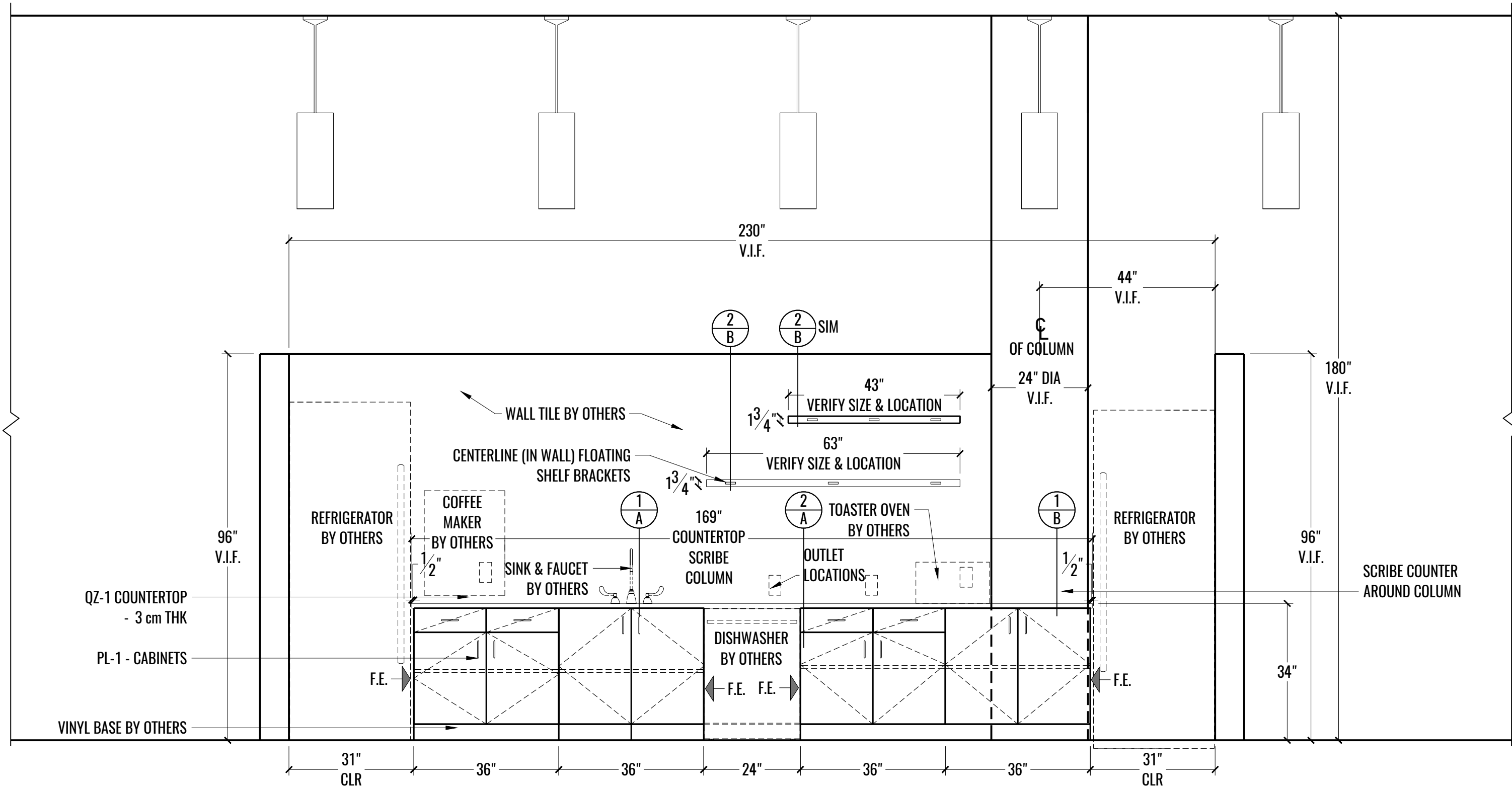

1  
3 ELEVATION: KITCHEN RM# 303 @ WALL  
SCALE: 1/2" = 1'-0"

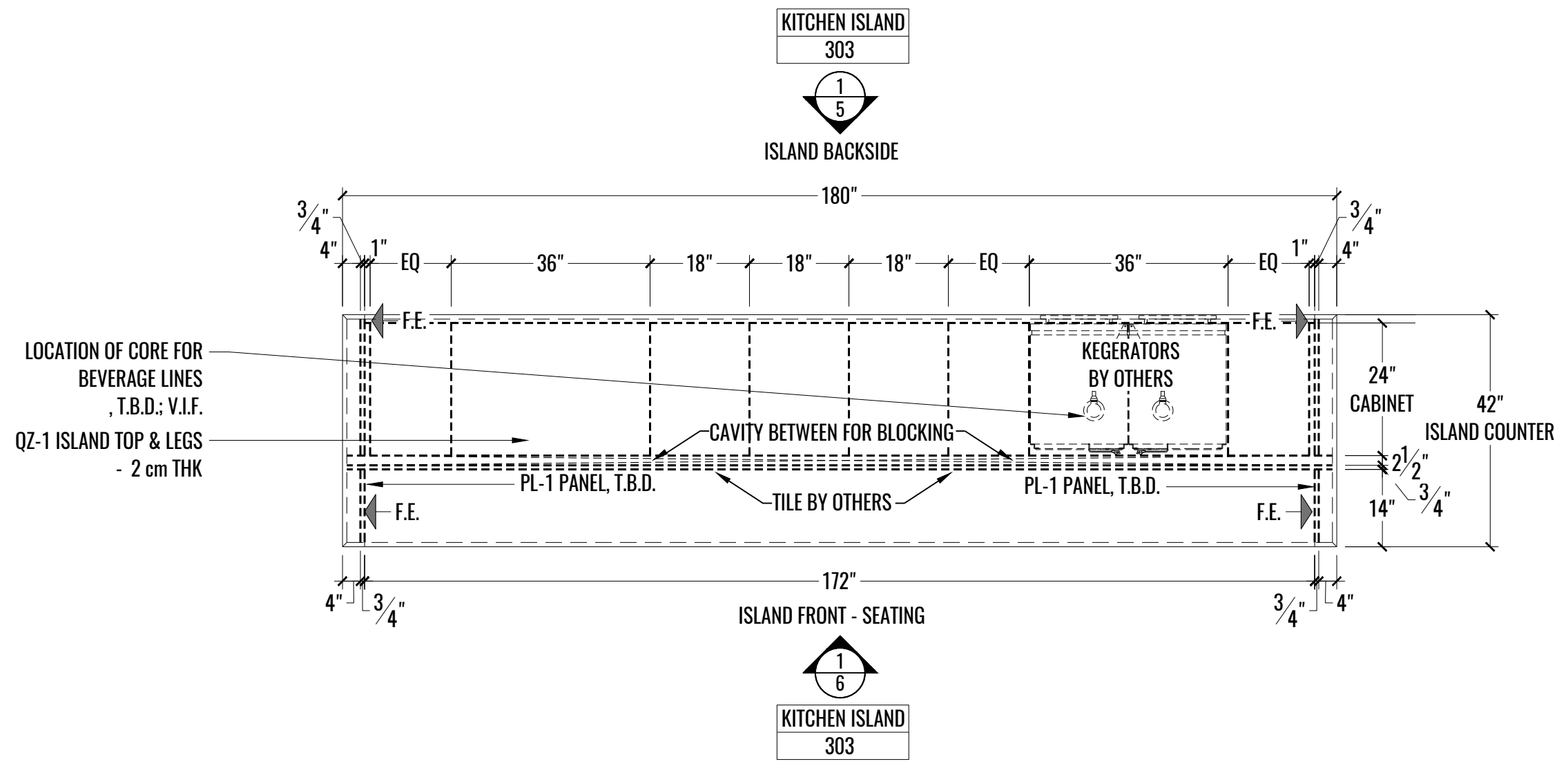

1 PLAN: KITCHEN ISLAND RM# 303  
 4 SCALE: 1/2" = 1'-0"

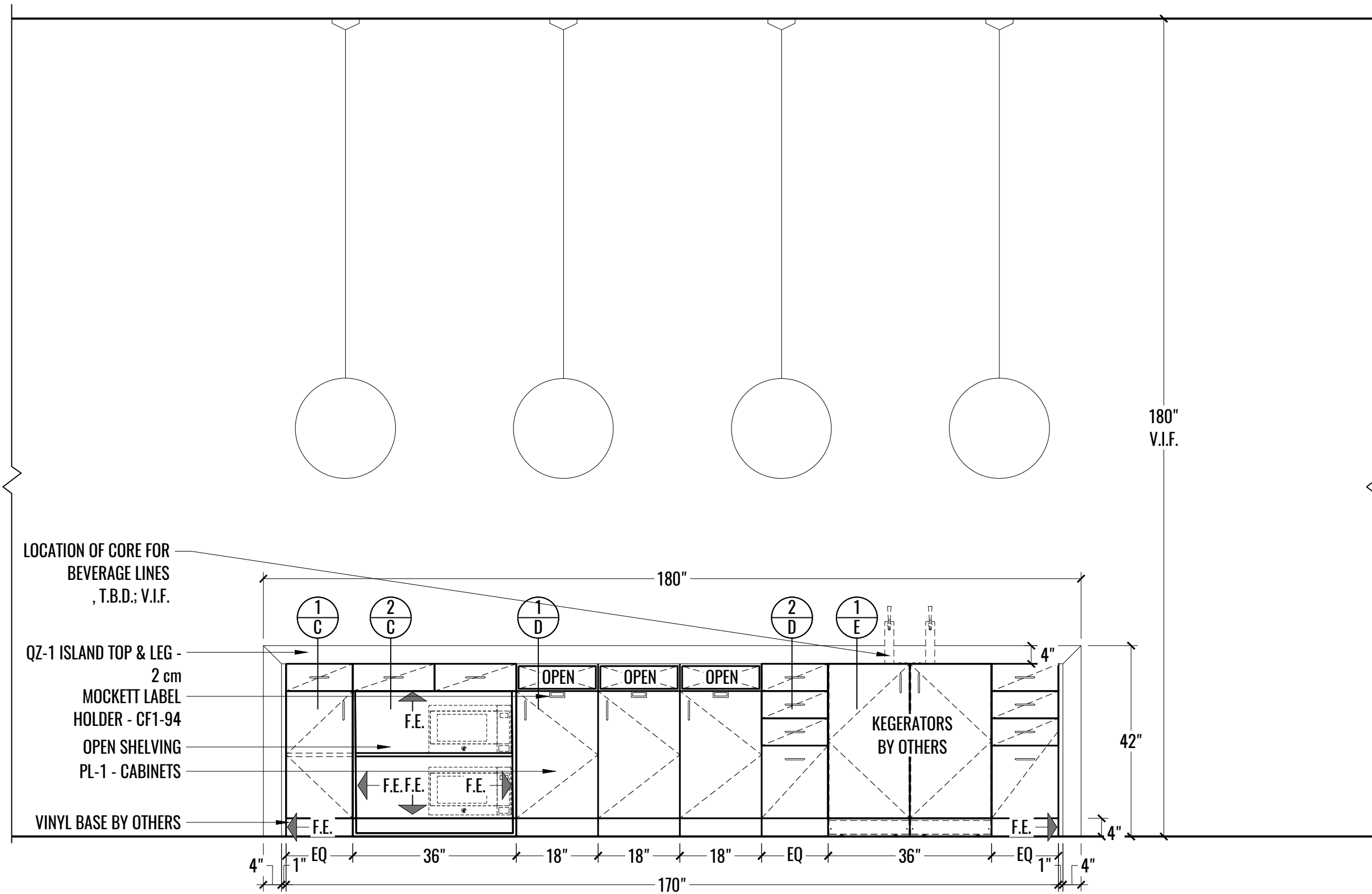

LOCATION OF CORE FOR BEVERAGE LINES, T.B.D.; V.I.F.

QZ-1 ISLAND TOP & LEG - 2 cm

MOCKETT LABEL HOLDER - CF1-94

OPEN SHELVING

PL-1 - CABINETS

VINYL BASE BY OTHERS

1 ELEVATION: KITCHEN ISLAND RM# 303 @ (BACK SIDE)  
 5 SCALE: 1/2" = 1'-0"

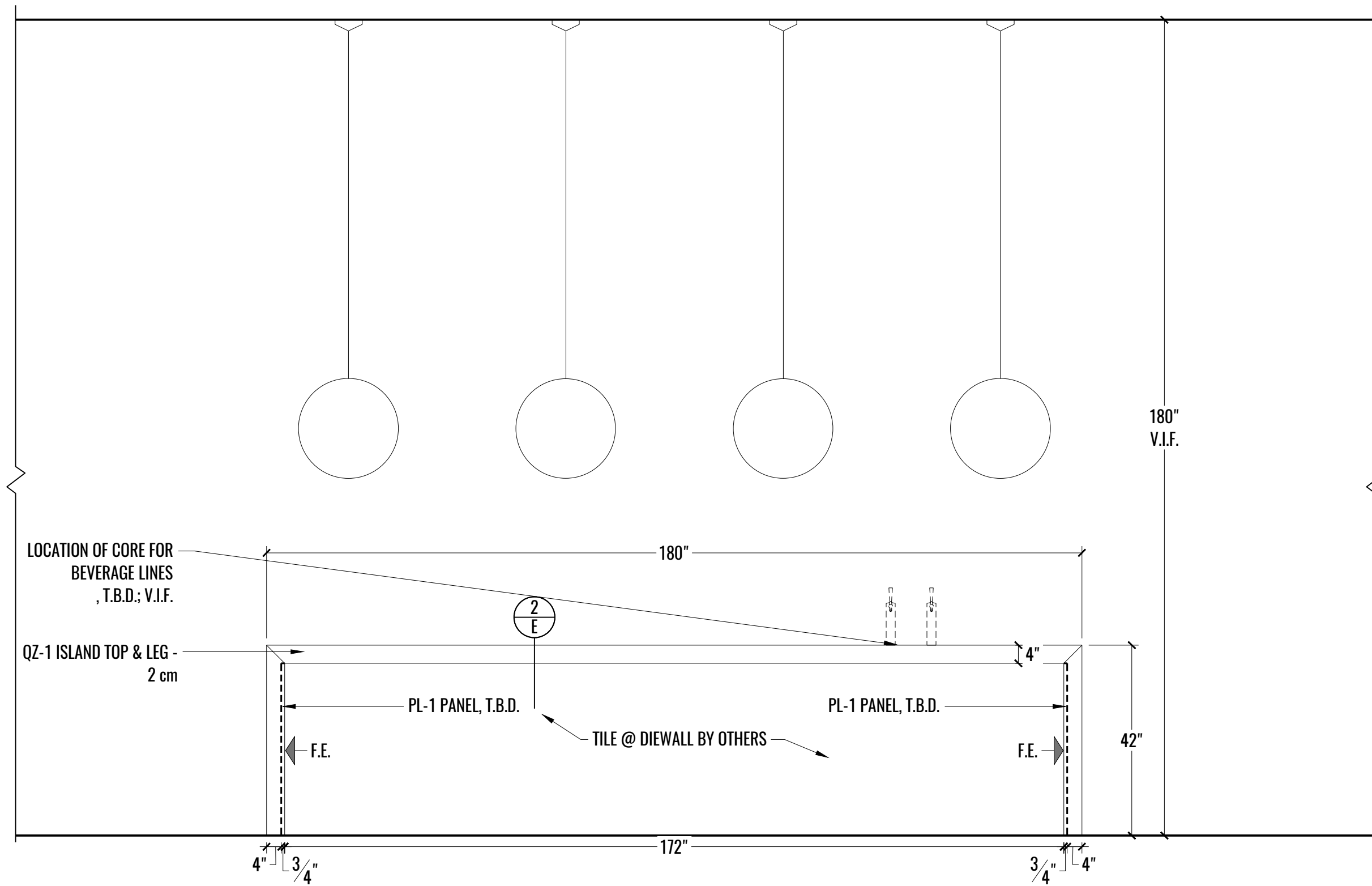

1 ELEVATION: KITCHEN ISLAND RM# 303 @ SEATING SIDE  
6 SCALE: 1/2" = 1'-0"

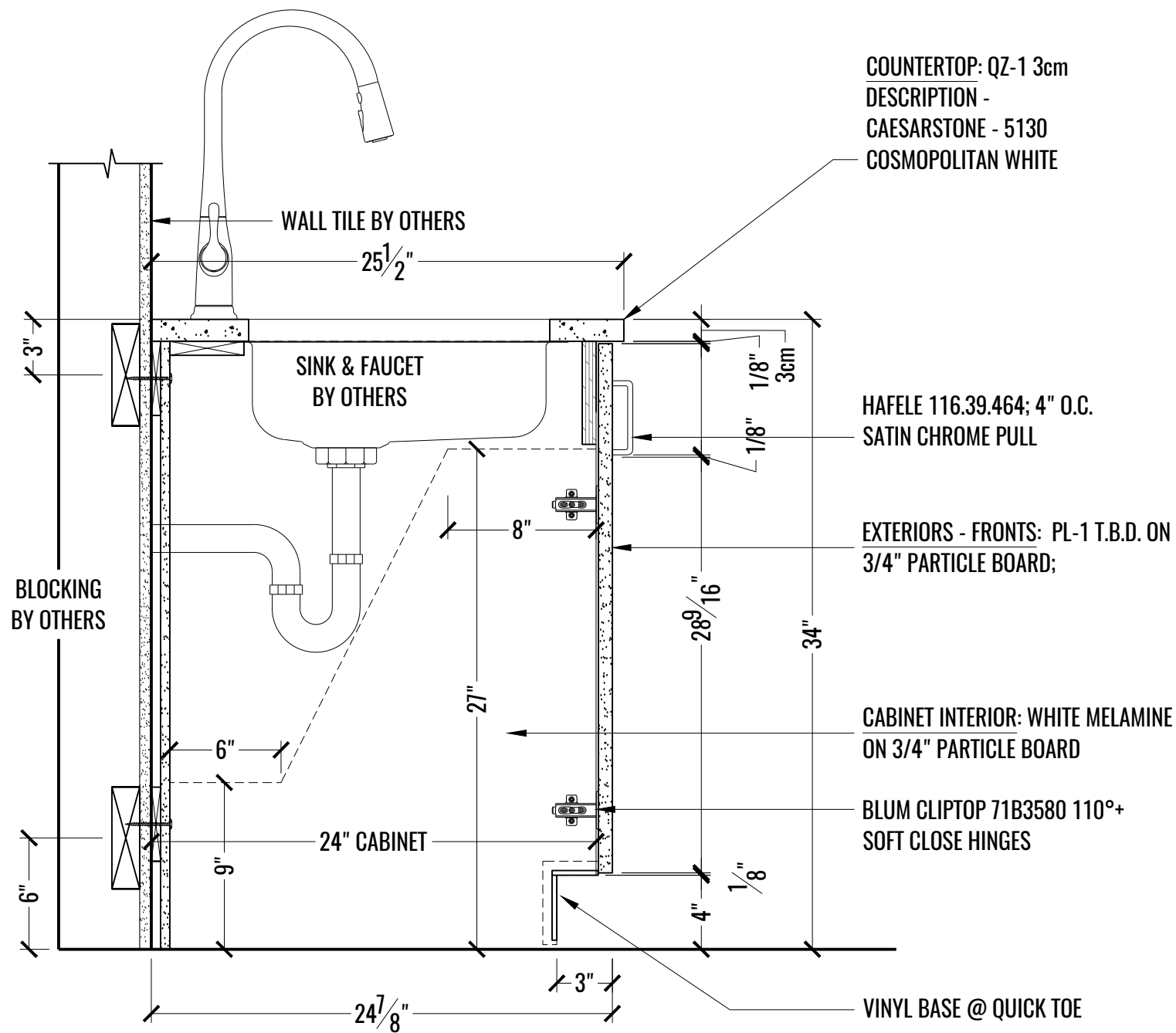

1 SECTION: KITCHEN RM# 303 @ SINK  
A SCALE: 1-1/2" = 1'-0"

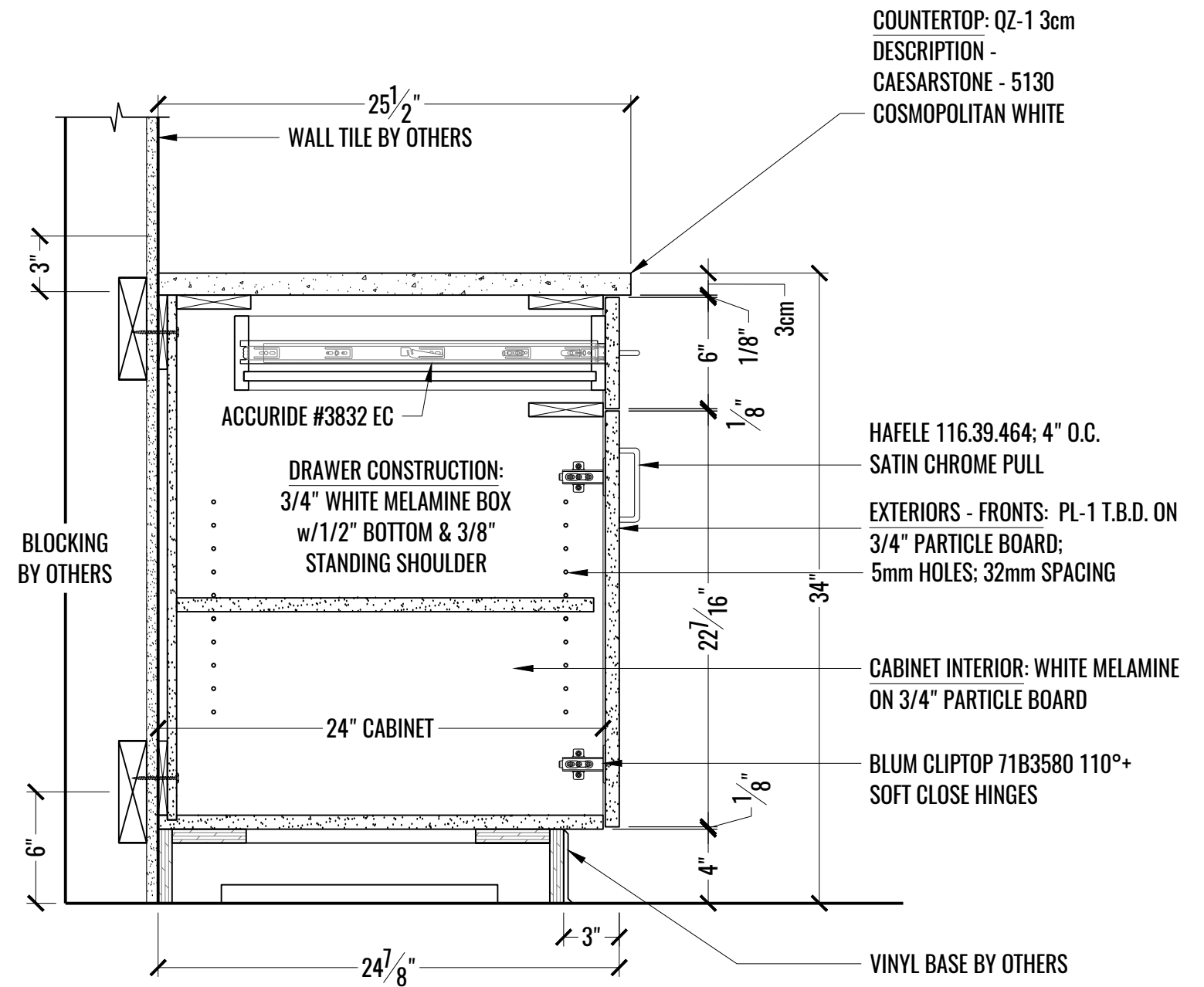

2 SECTION: KITCHEN RM# 303 - BASE CABINETS  
A SCALE: 1-1/2" = 1'-0"

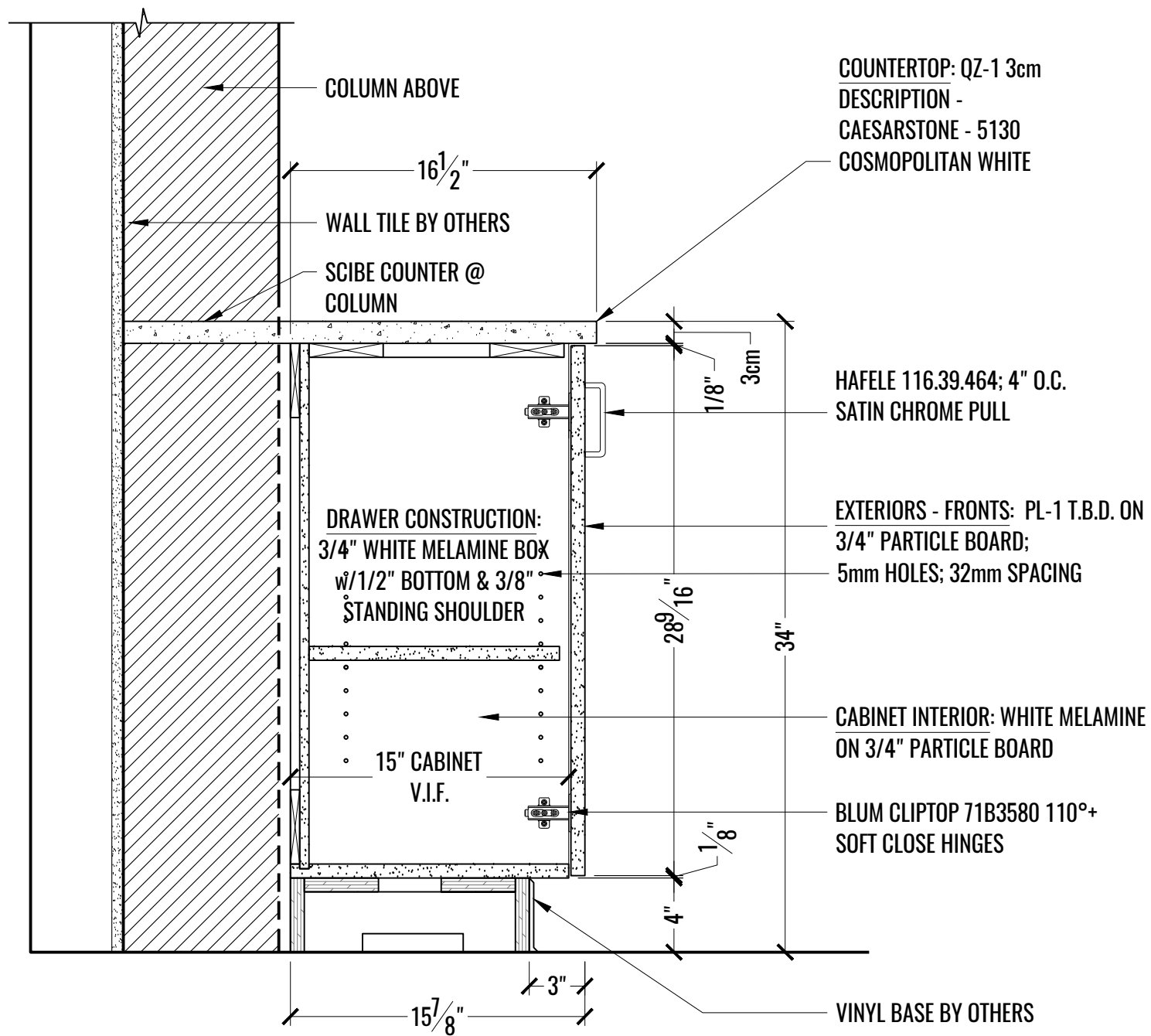

1 SECTION: KITCHEN RM# 303 - BASE CABINET @ COLUMN  
B SCALE: 1-1/2" = 1'-0"

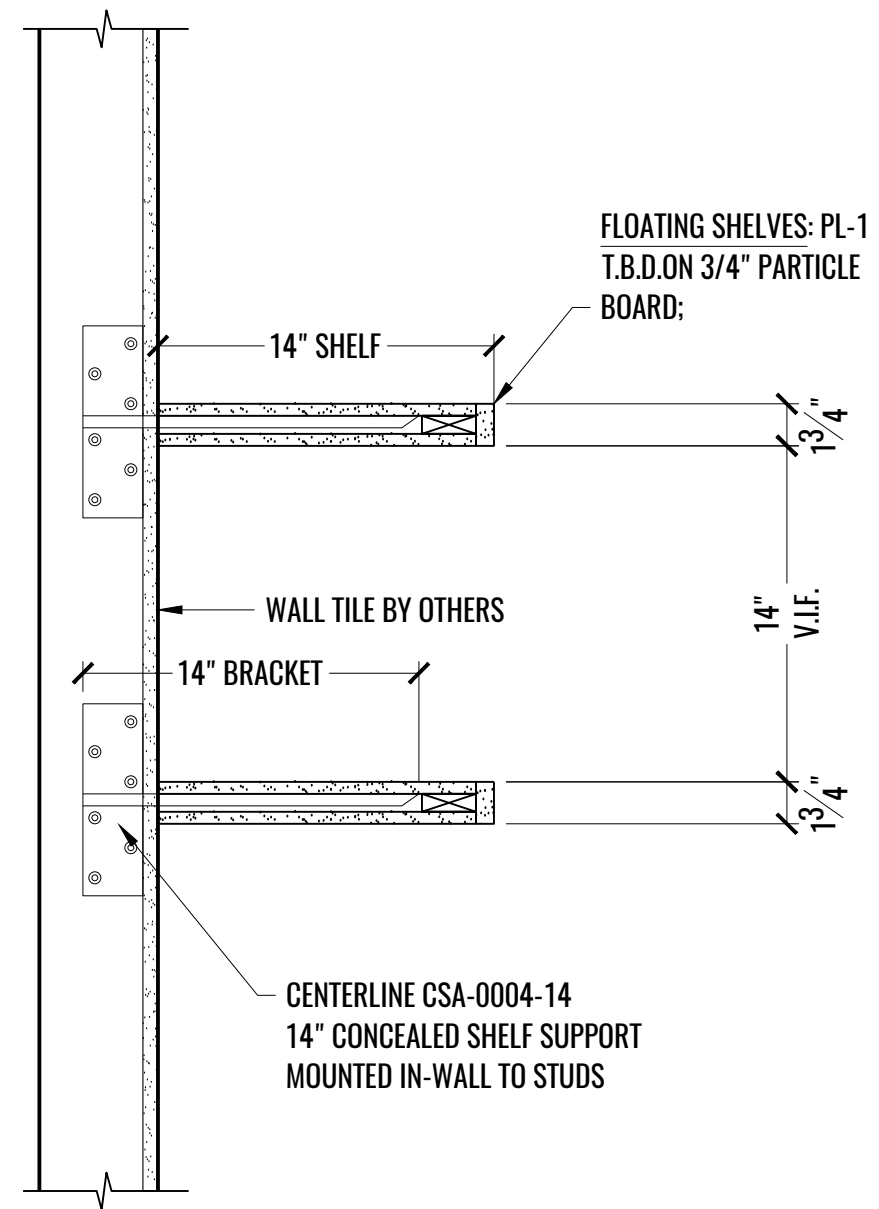

2 SECTION: KITCHEN RM# 303 - FLOATING SHELVES  
B SCALE: 1-1/2" = 1'-0"



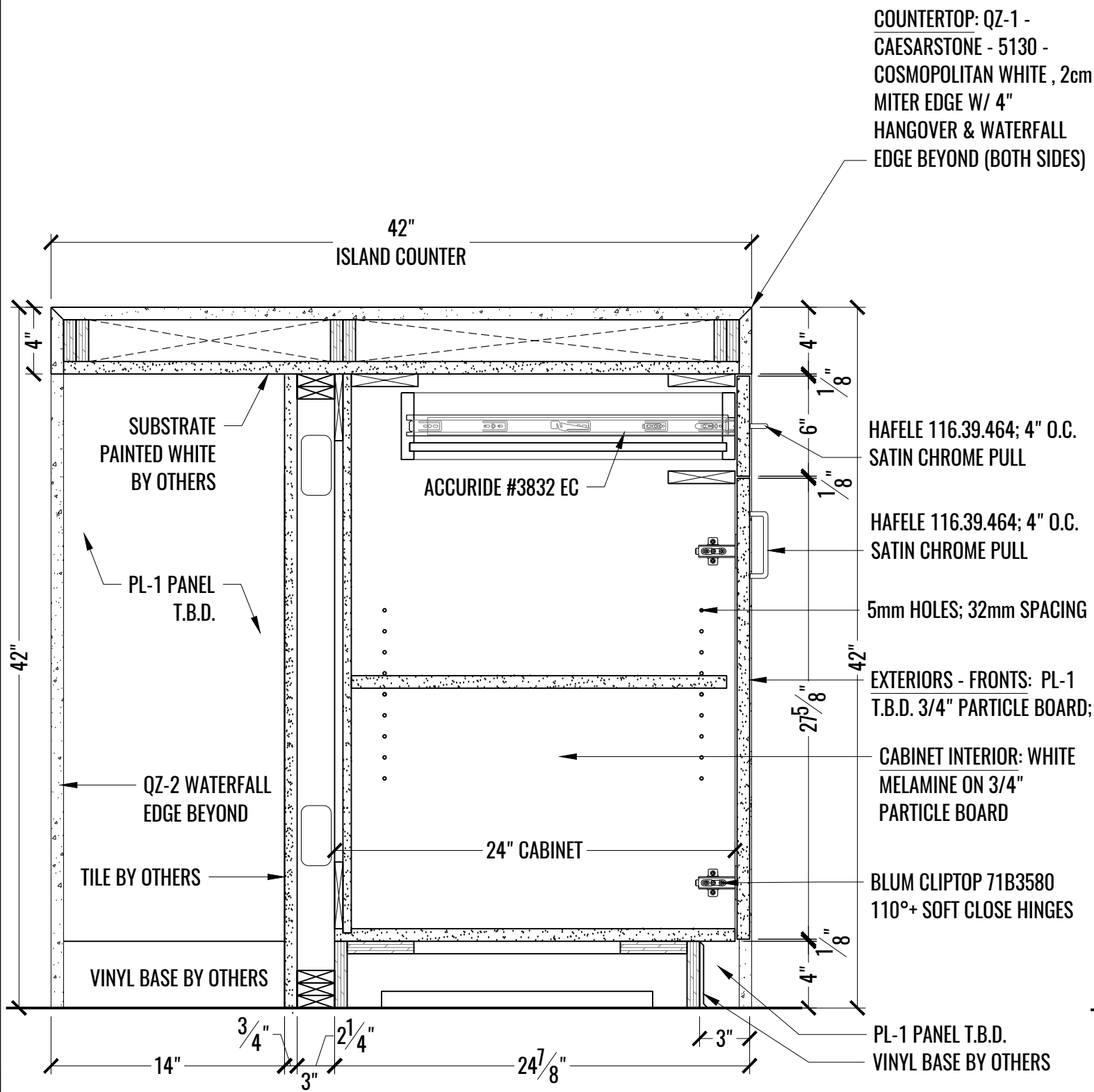

1 SECTION: KITCHEN ISLAND RM# 303 @ BASE CABINET W/DRAWER  
C SCALE: 1-1/2" = 1'-0"

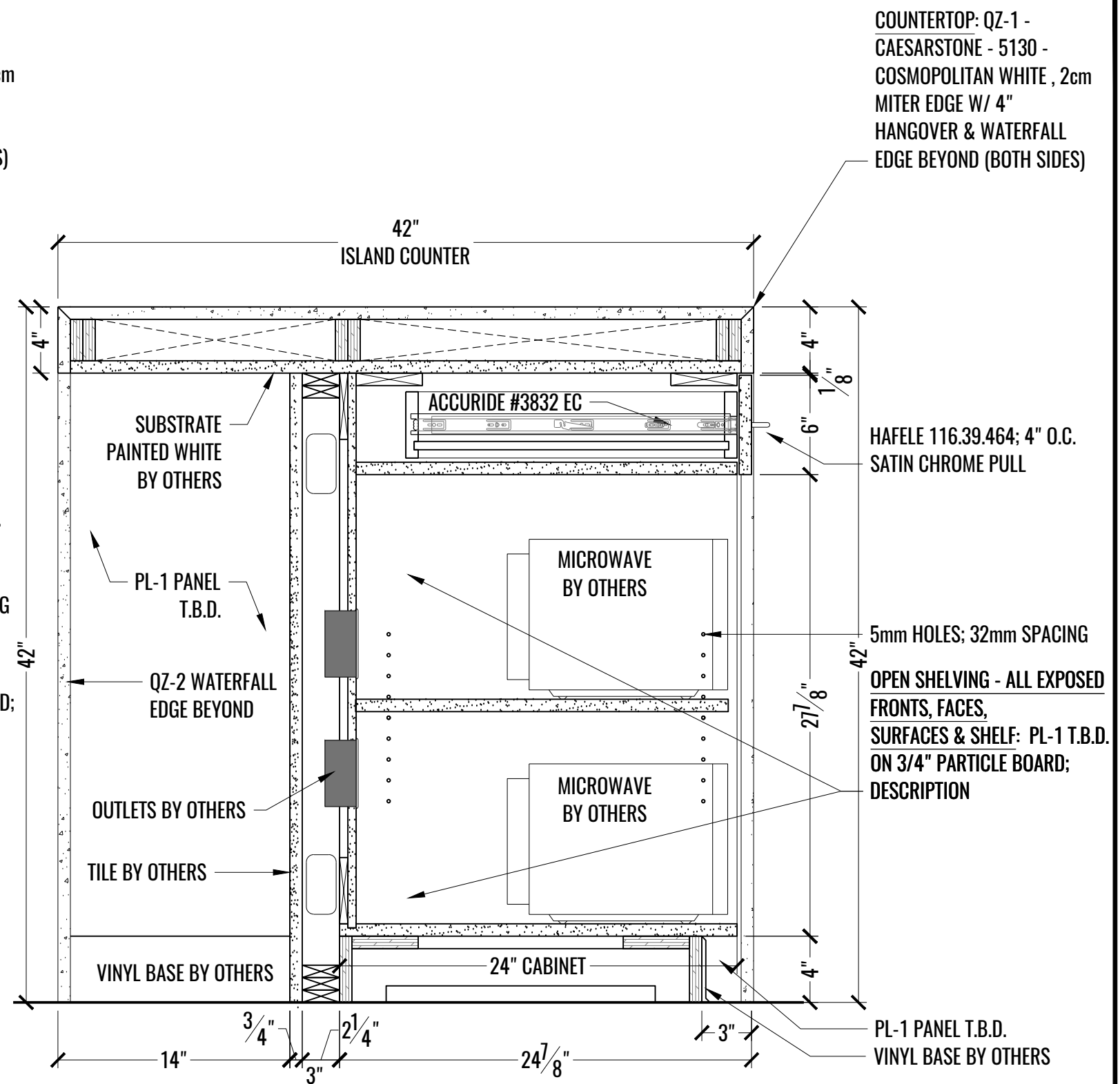

2 SECTION: KITCHEN ISLAND RM# 303 - @ OPEN SHELVING & DRAWER  
C SCALE: 1-1/2" = 1'-0"

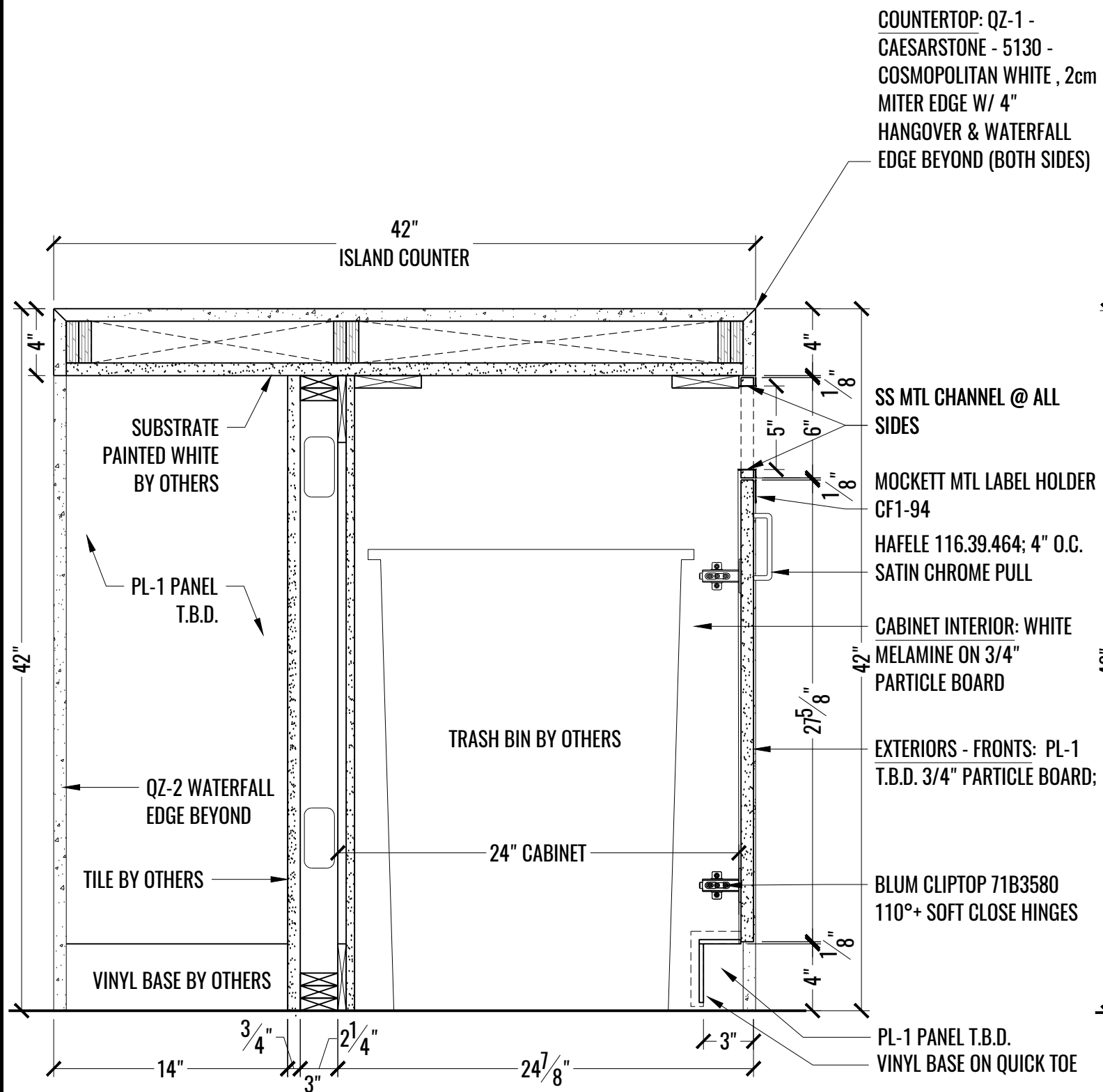

1 SECTION: KITCHEN ISLAND RM# 303 @ TRASH BINS  
D SCALE: 1-1/2" = 1'-0"

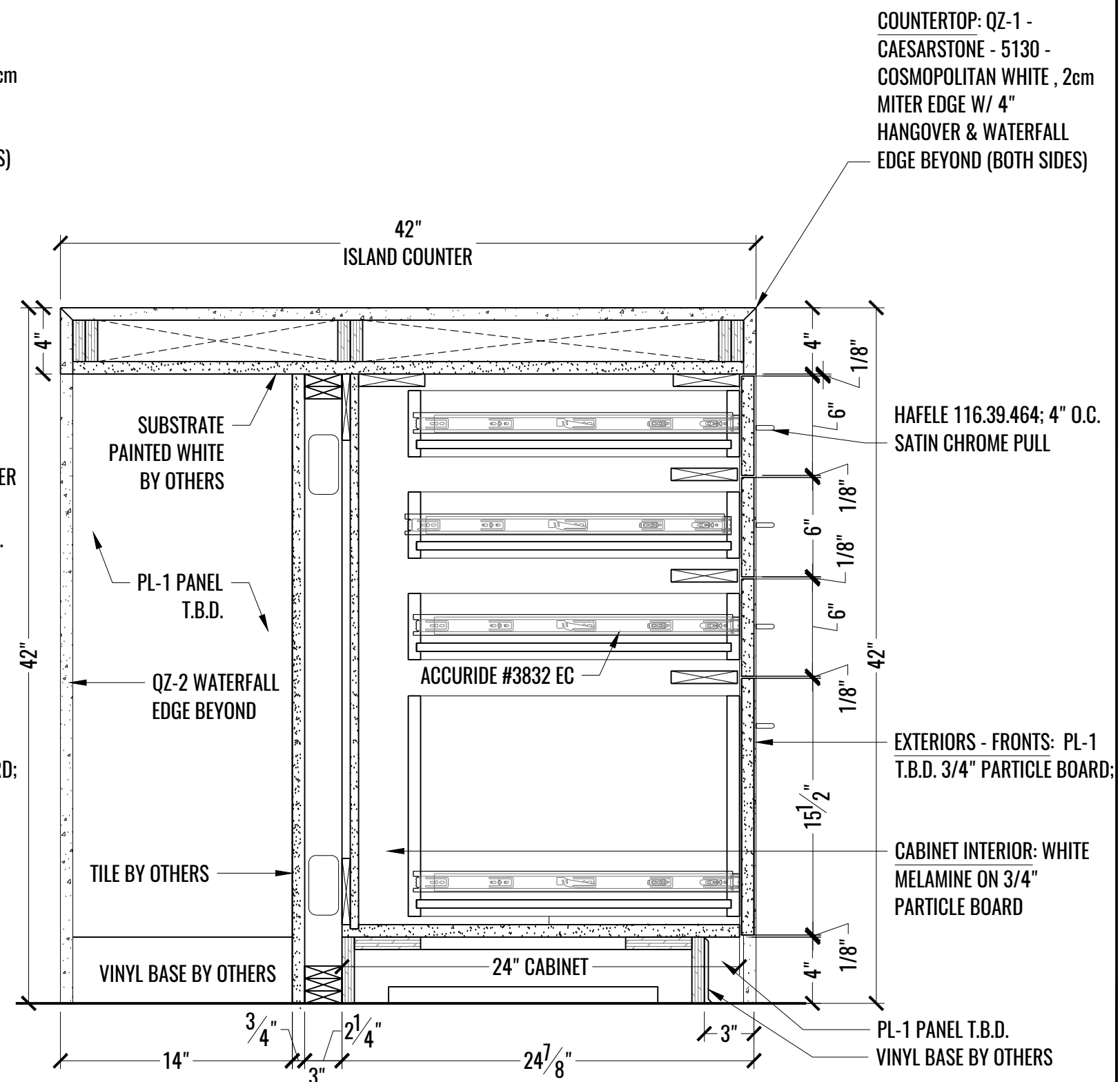

1 SECTION: KITCHEN ISLAND RM# 303 @ DRAWERS  
E SCALE: 1-1/2" = 1'-0"

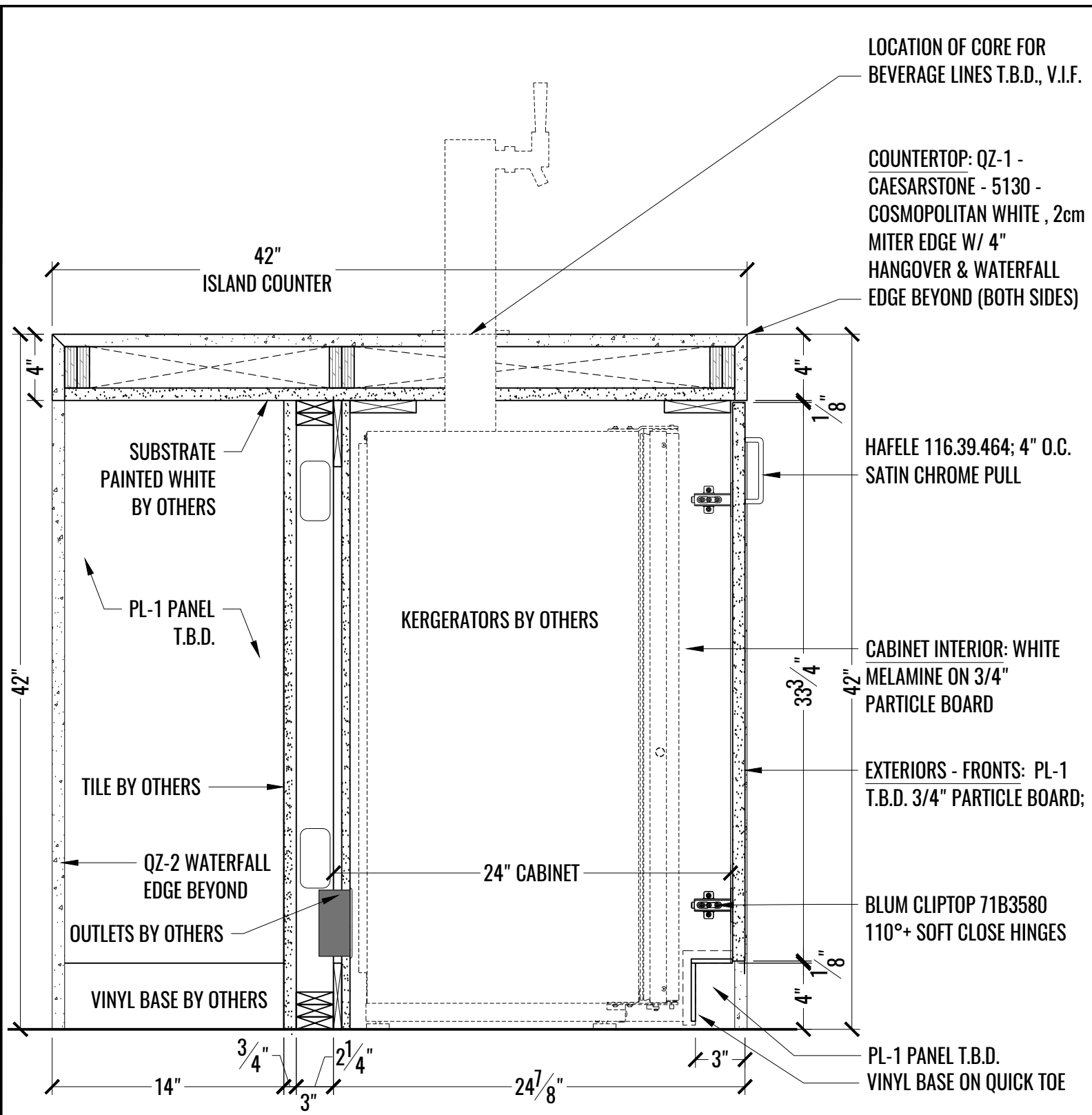

1 SECTION: KITCHEN ISLAND RM# 303 @ KERGERATORS  
E SCALE: 1-1/2" = 1'-0"

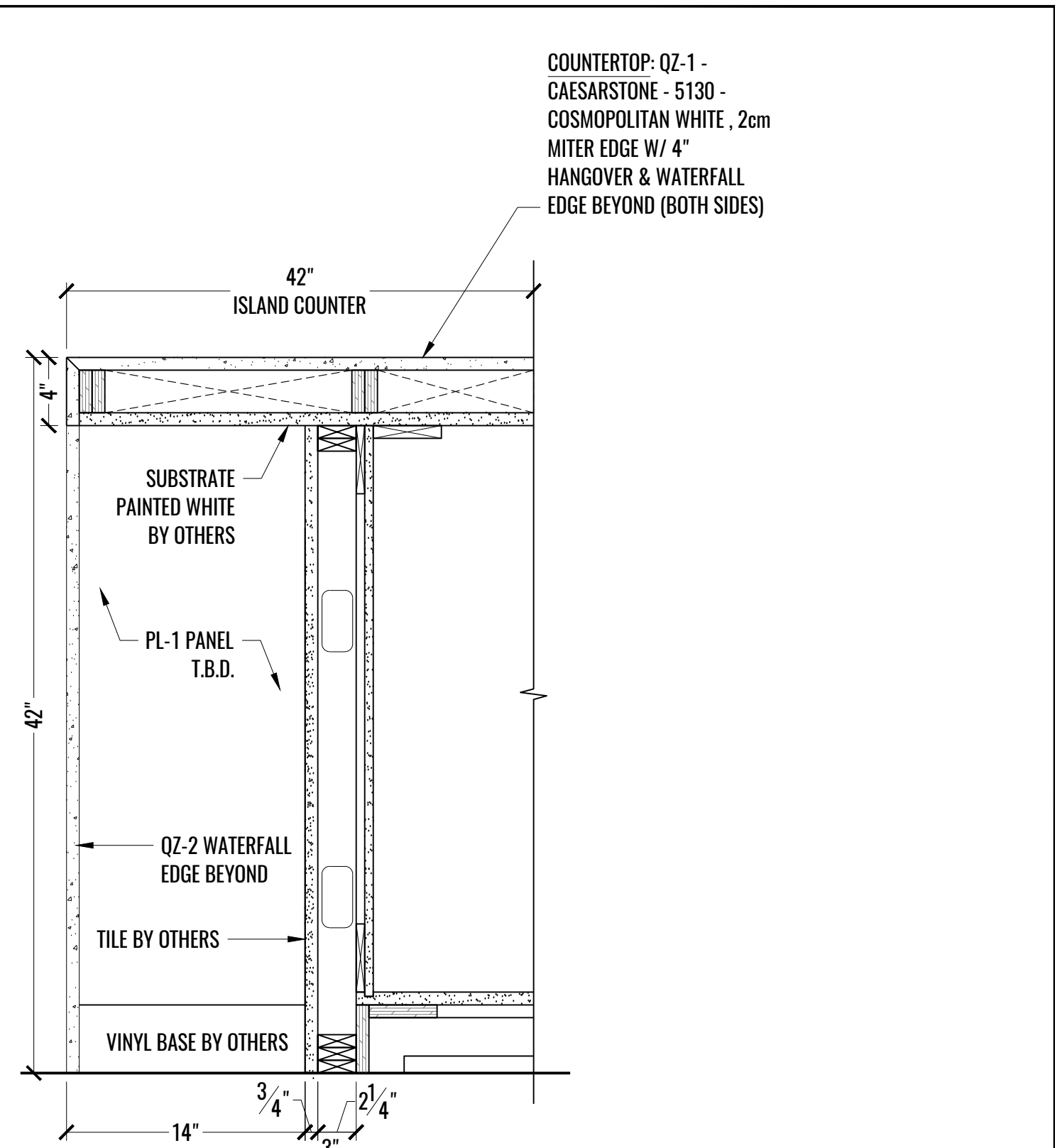

2 SECTION: KITCHEN ISLAND RM# 303 - SEATING SIDE  
E SCALE: 1-1/2" = 1'-0"