

1 PLAN: PROJECT SCOPE - 15TH FLOOR
1 SCALE: NOT TO SCALE

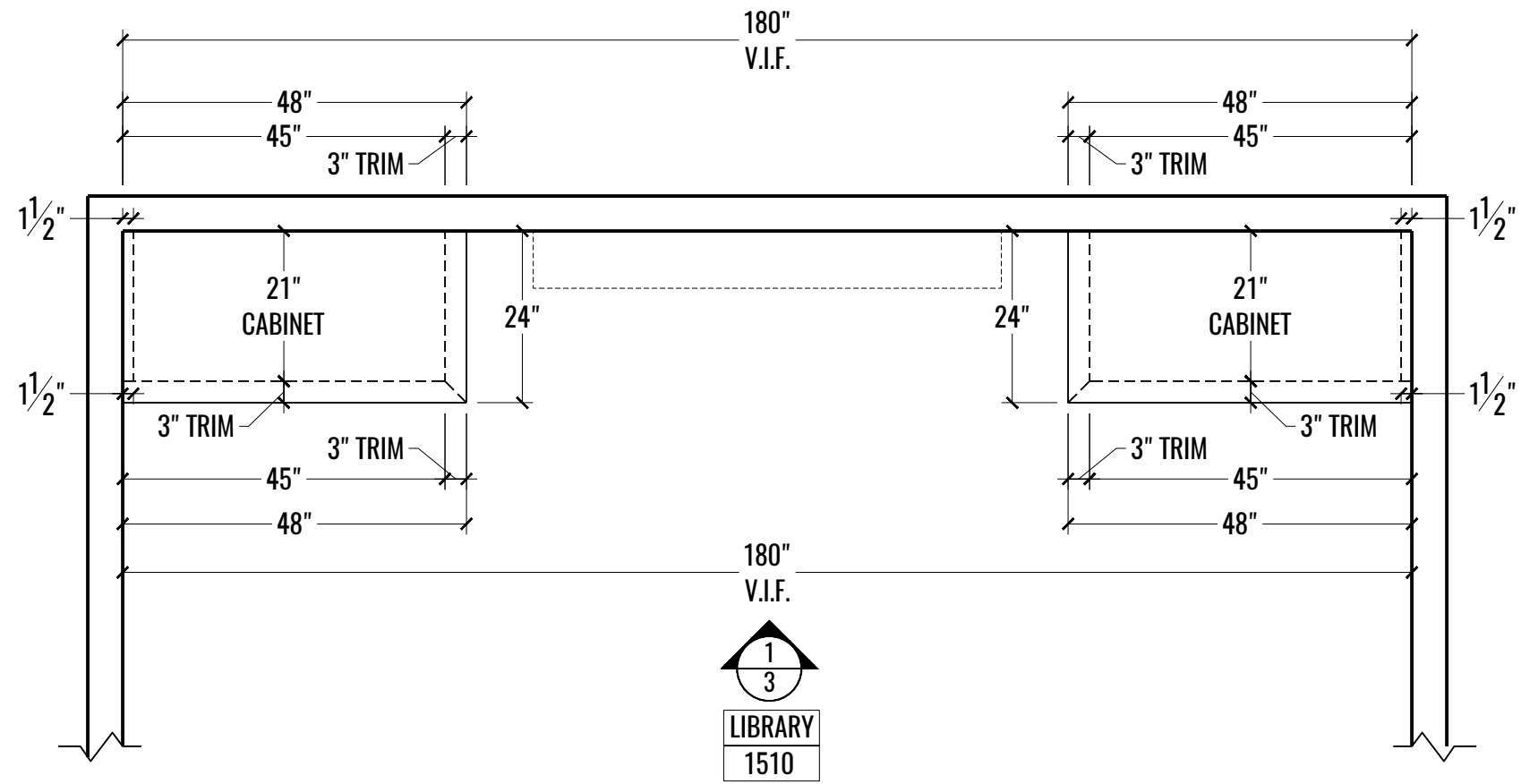

1
3
LIBRARY
1510

1 PLAN: LIBRARY - 1510
2 SCALE: 1/2" = 1'-0"

DRAWING NUMBER
MW2

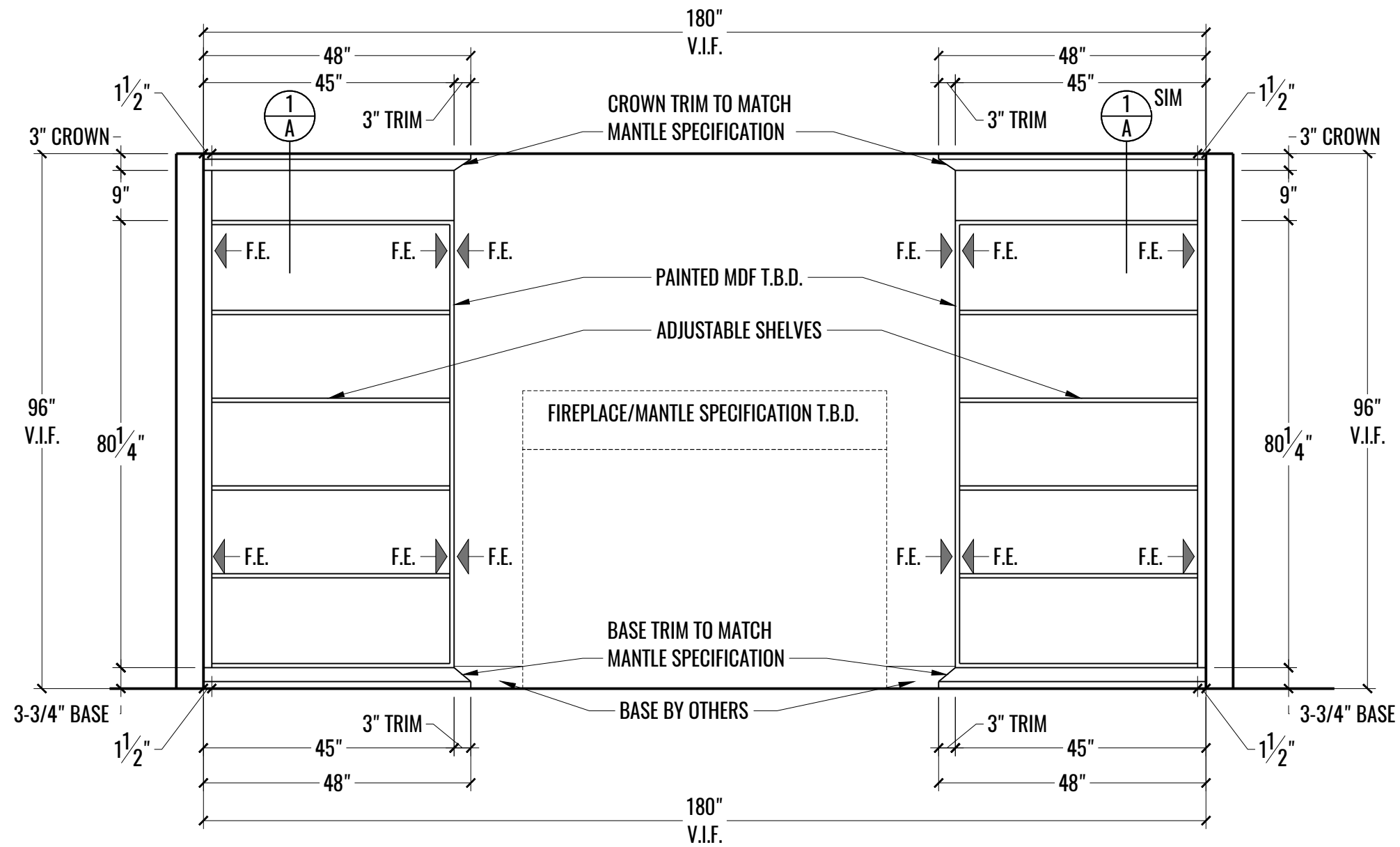

1 ELEVATION: LIBRARY - 1510
 3 SCALE: 1/2" = 1'-0"

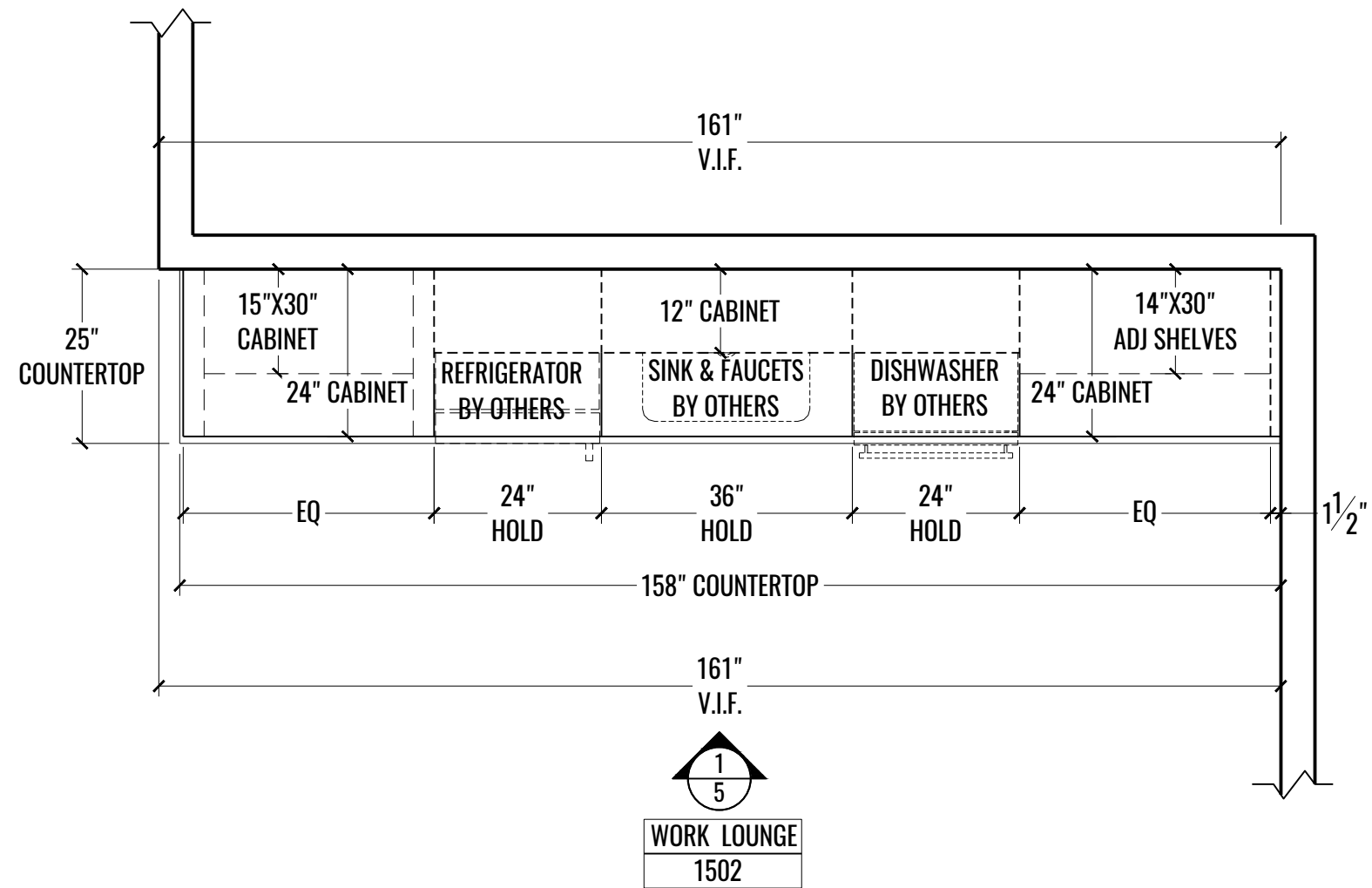

1 PLAN: WORK LOUNGE - 1502
4 SCALE: 1/2" = 1'-0"

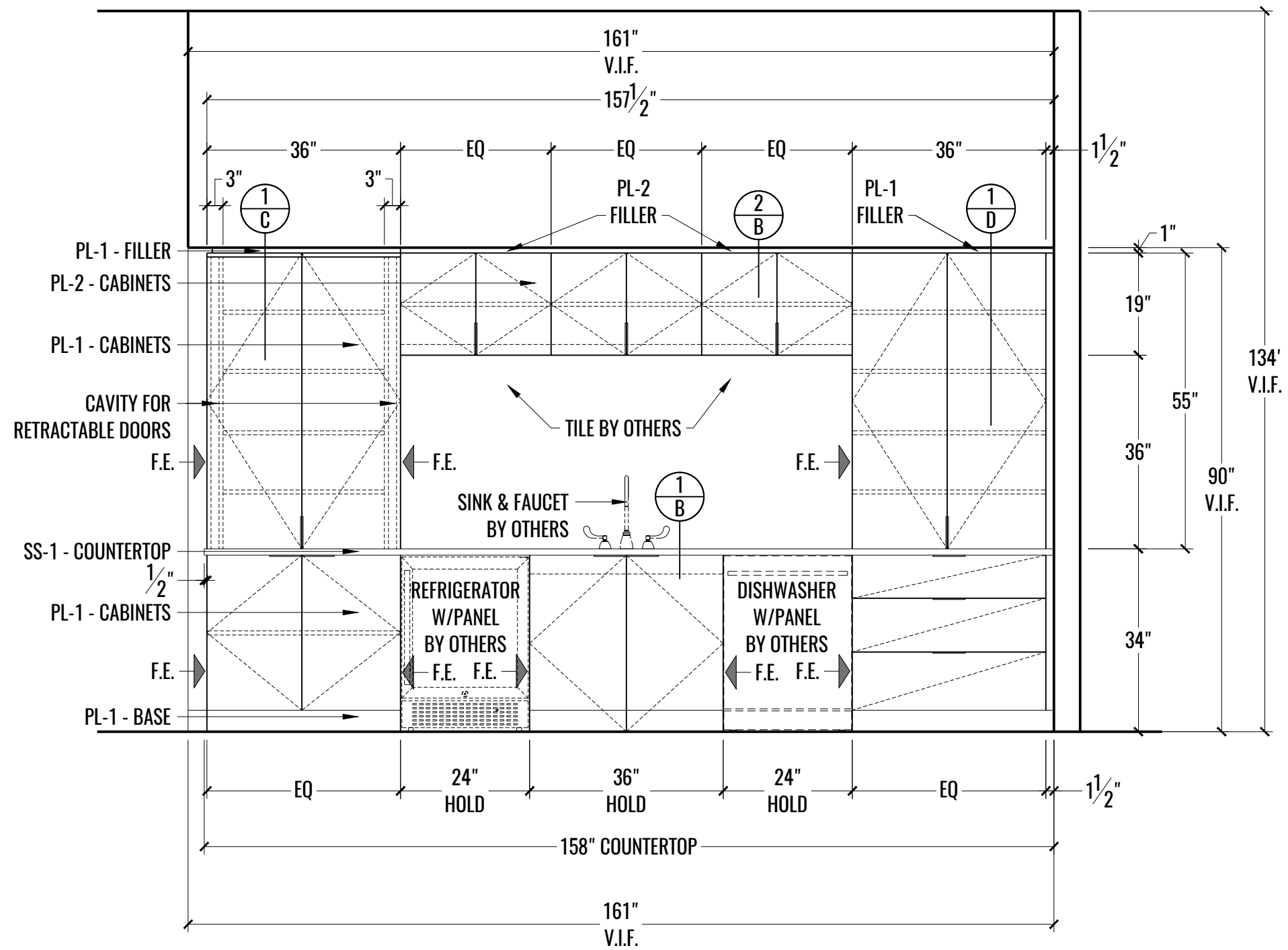

1
 5

ELEVATION: WORK LOUNGE - 1502
 SCALE: 1/2" = 1'-0"

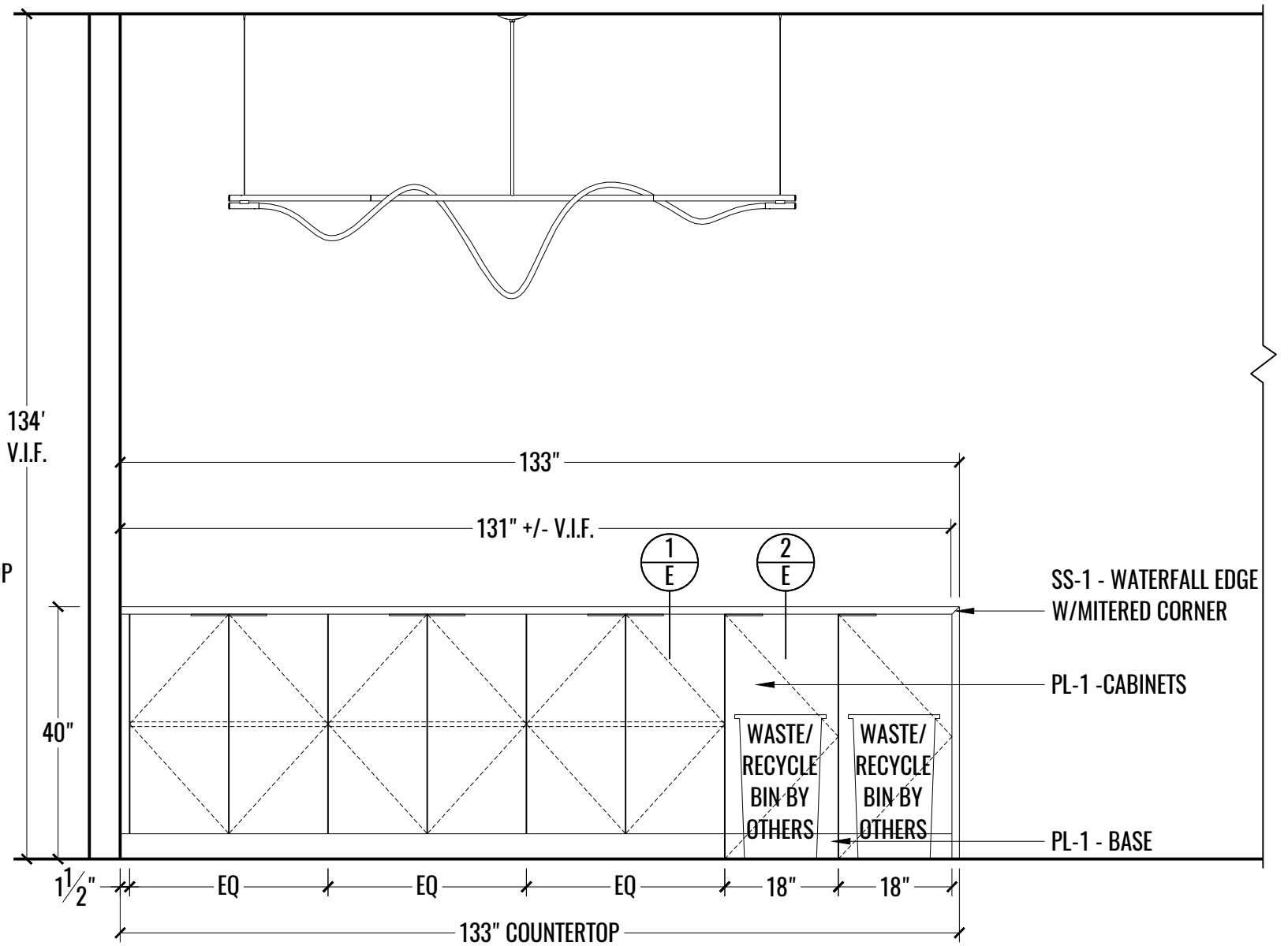
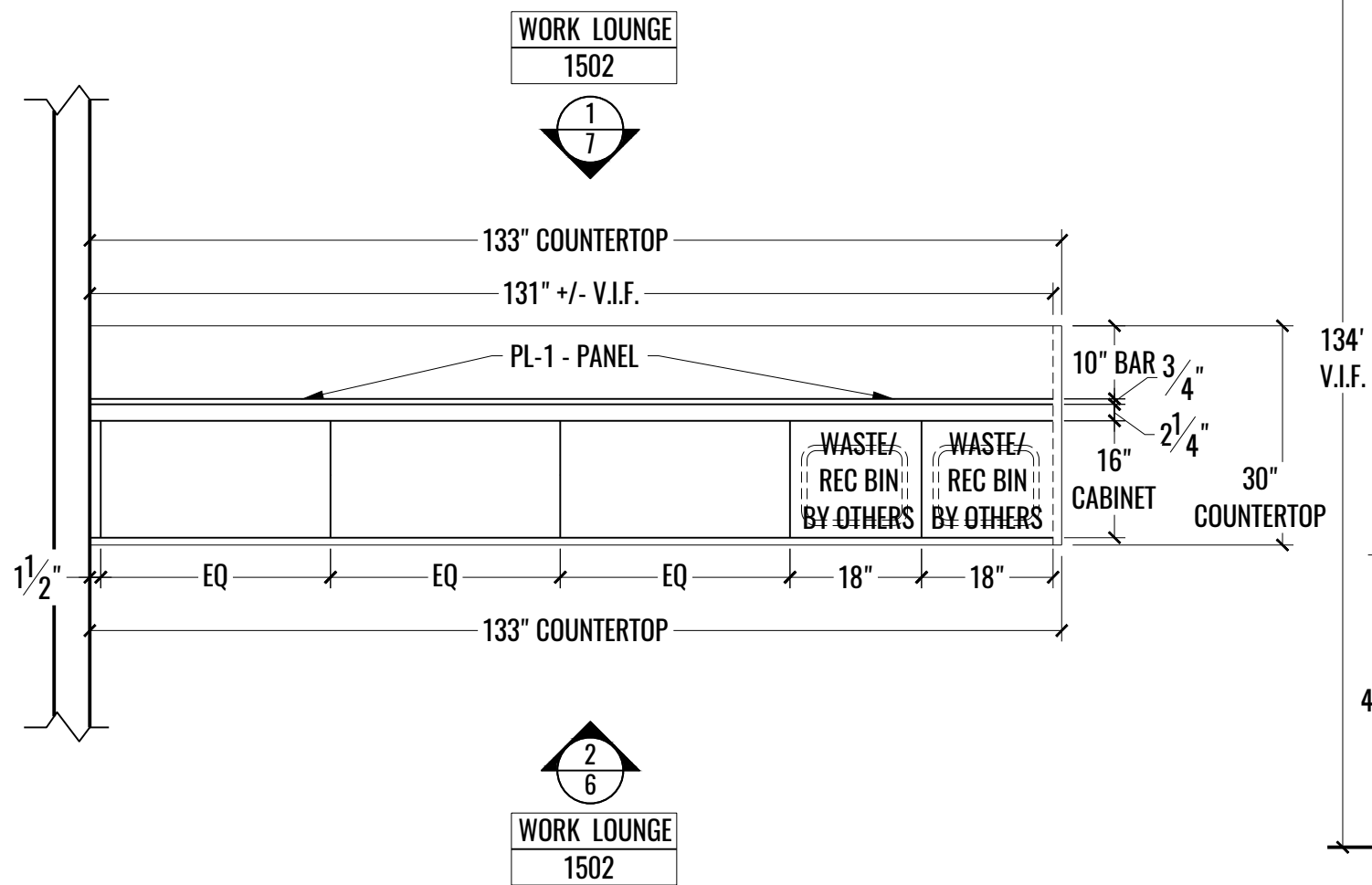

1 PLAN: WORK LOUNGE - ISLAND - 1502
6 SCALE: 1/2" = 1'-0"

2 ELEVATION: WORK LOUNGE - ISLAND (REAR VIEW) - 1502
6 SCALE: 1/2" = 1'-0"

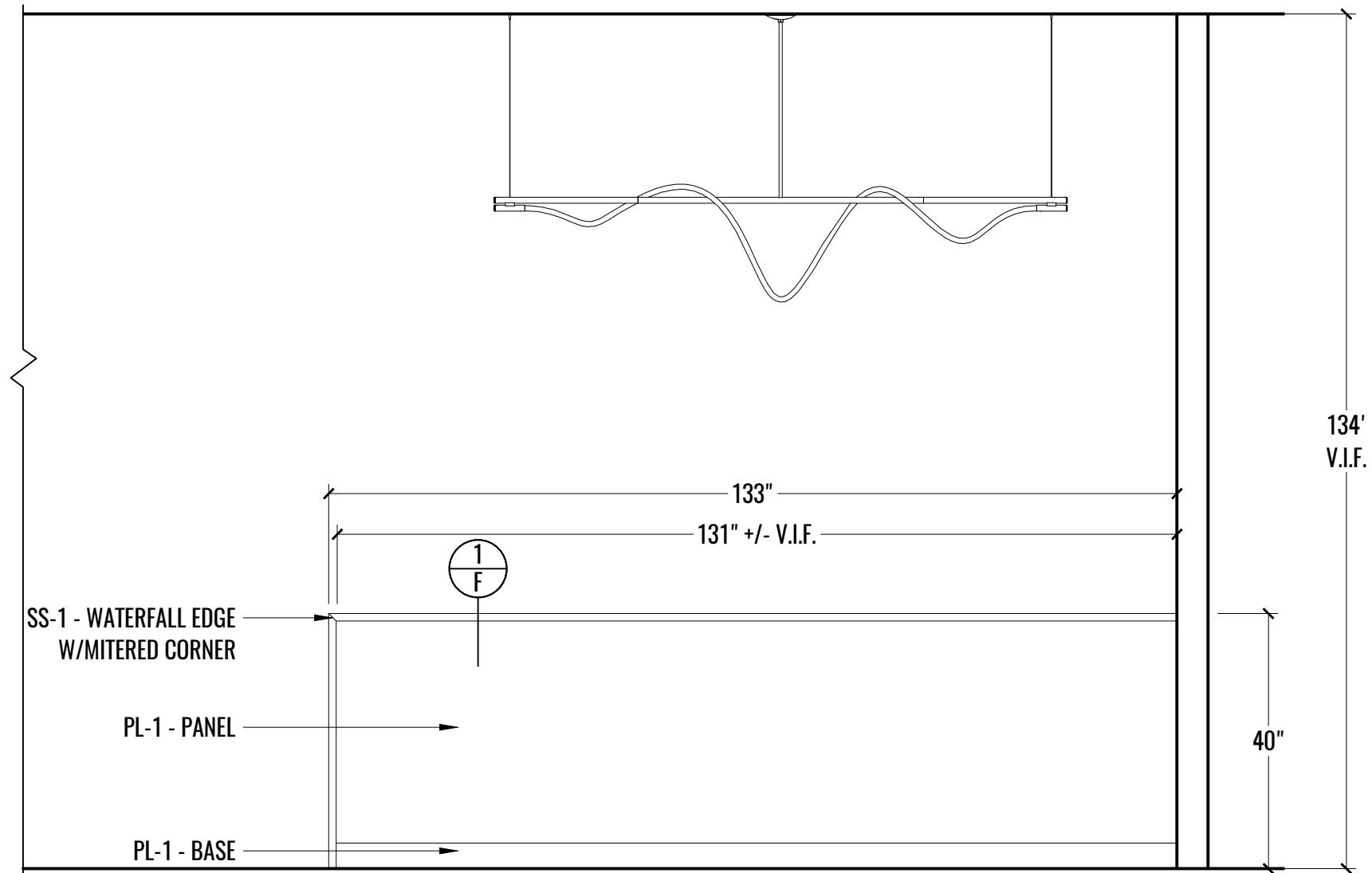

1 ELEVATION: WORK LOUNGE - ISLAND (FRONT VIEW) - 1502
7 SCALE: 1/2" = 1'-0"

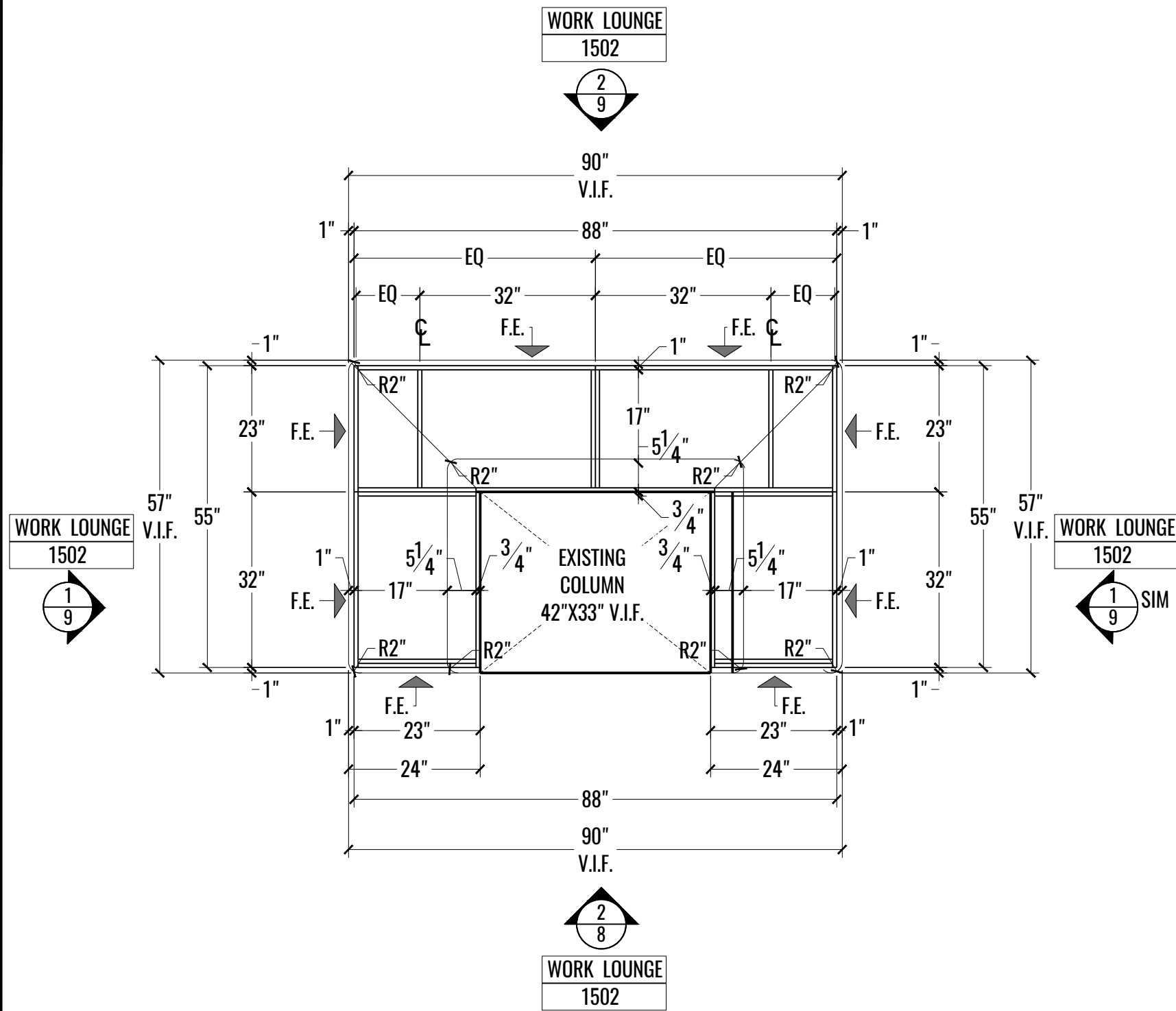

1 PLAN: WORK LOUNGE - BANQUETTE - 1502
 8 SCALE: 1/2" = 1'-0"

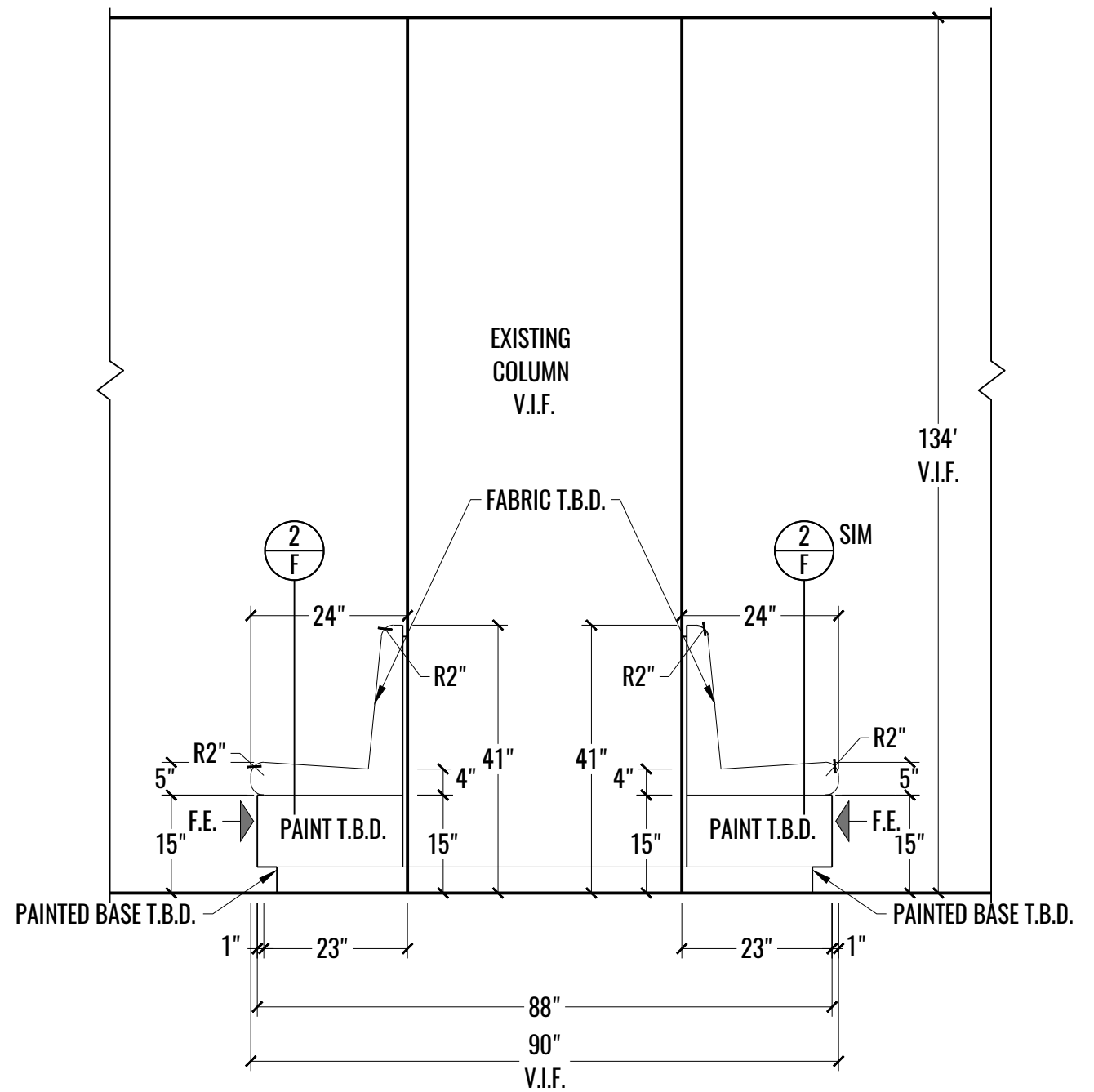

2 ELEVATION: WORK LOUNGE - BANQUETTE - 1502
 8 SCALE: 1/2" = 1'-0"

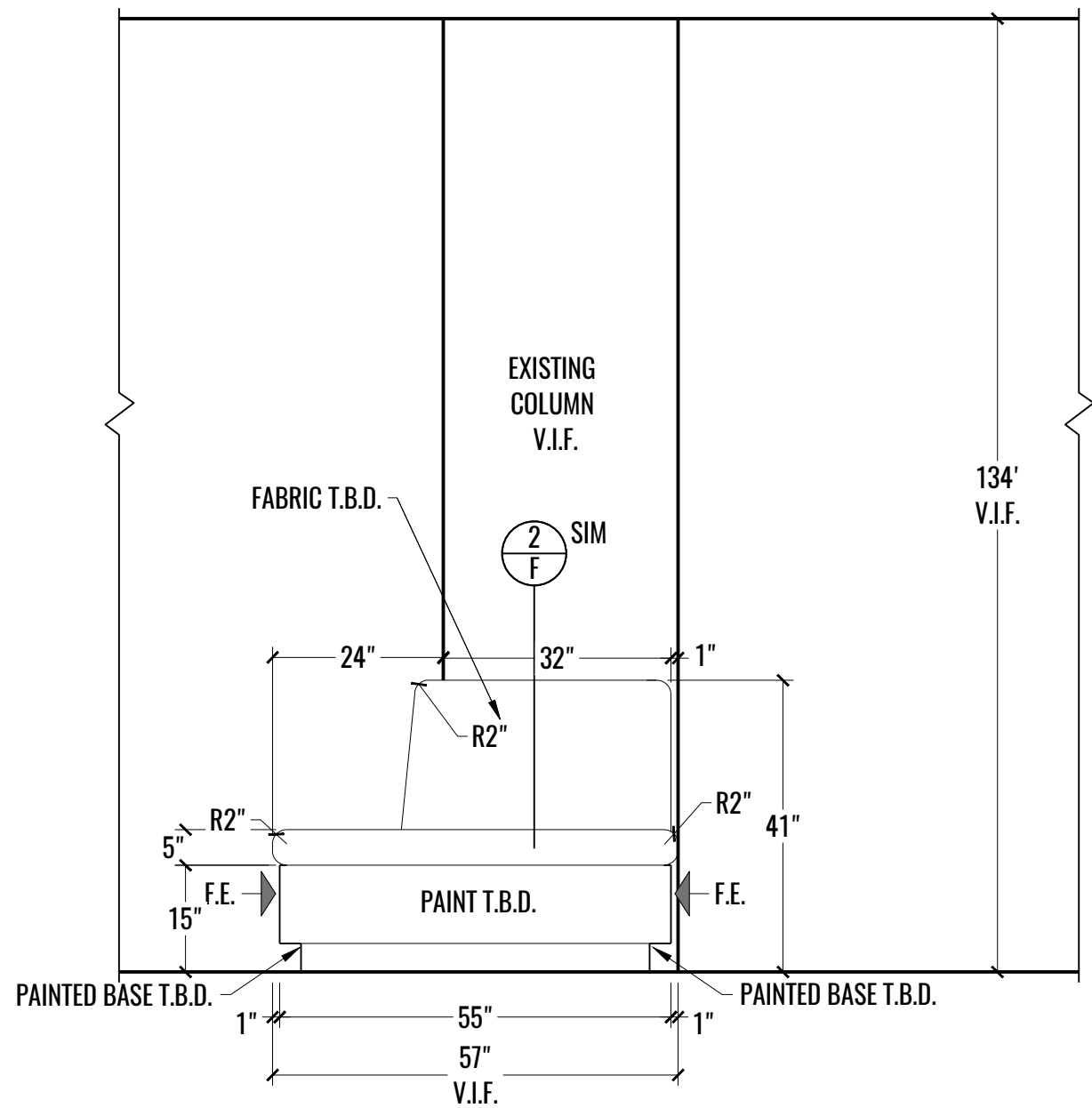

1 PLAN: WORK LOUNGE - BANQUETTE - 1502
 9 SCALE: 1/2" = 1'-0"

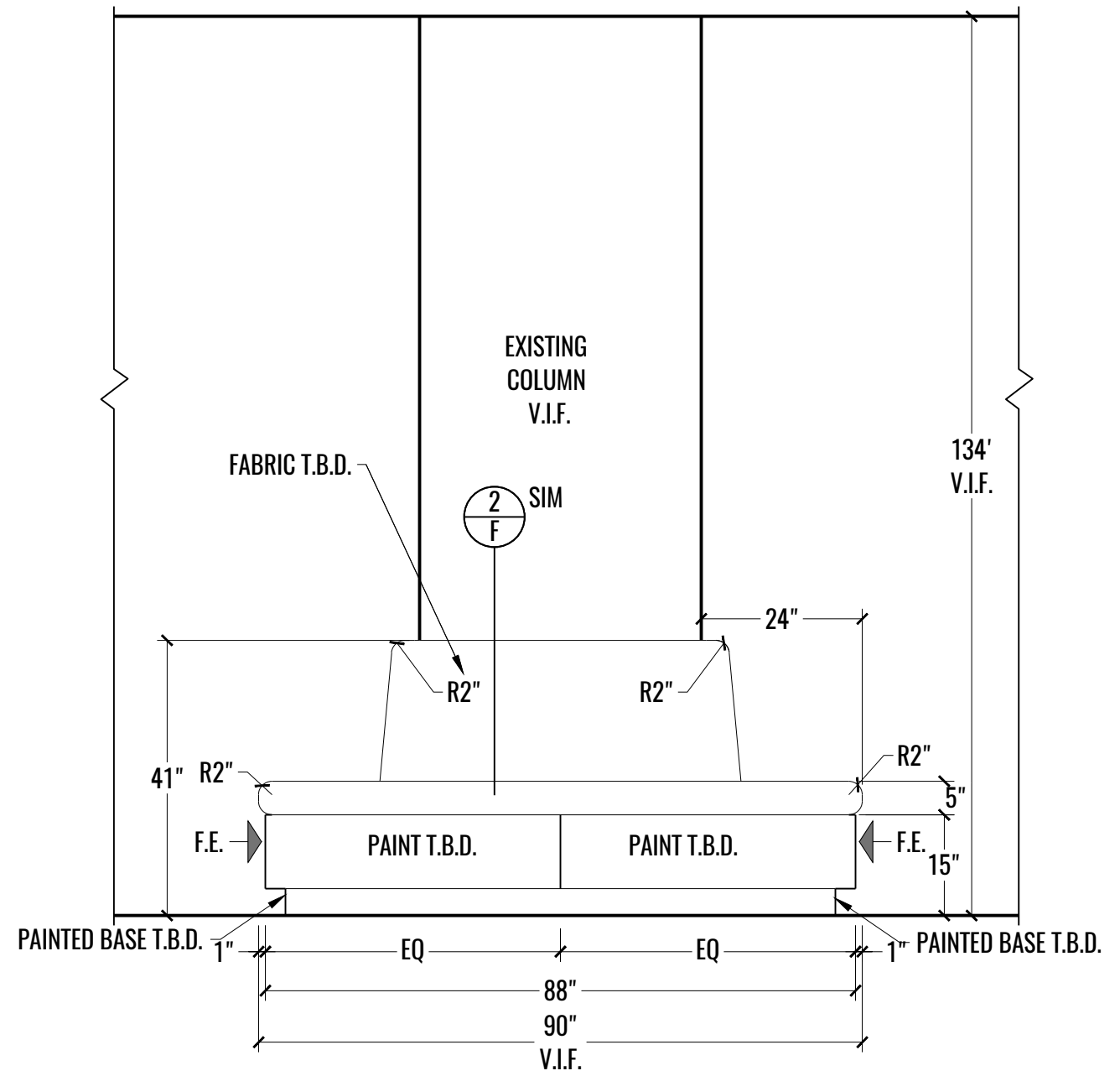

2 ELEVATION: WORK LOUNGE - BANQUETTE - 1502
 9 SCALE: 1/2" = 1'-0"

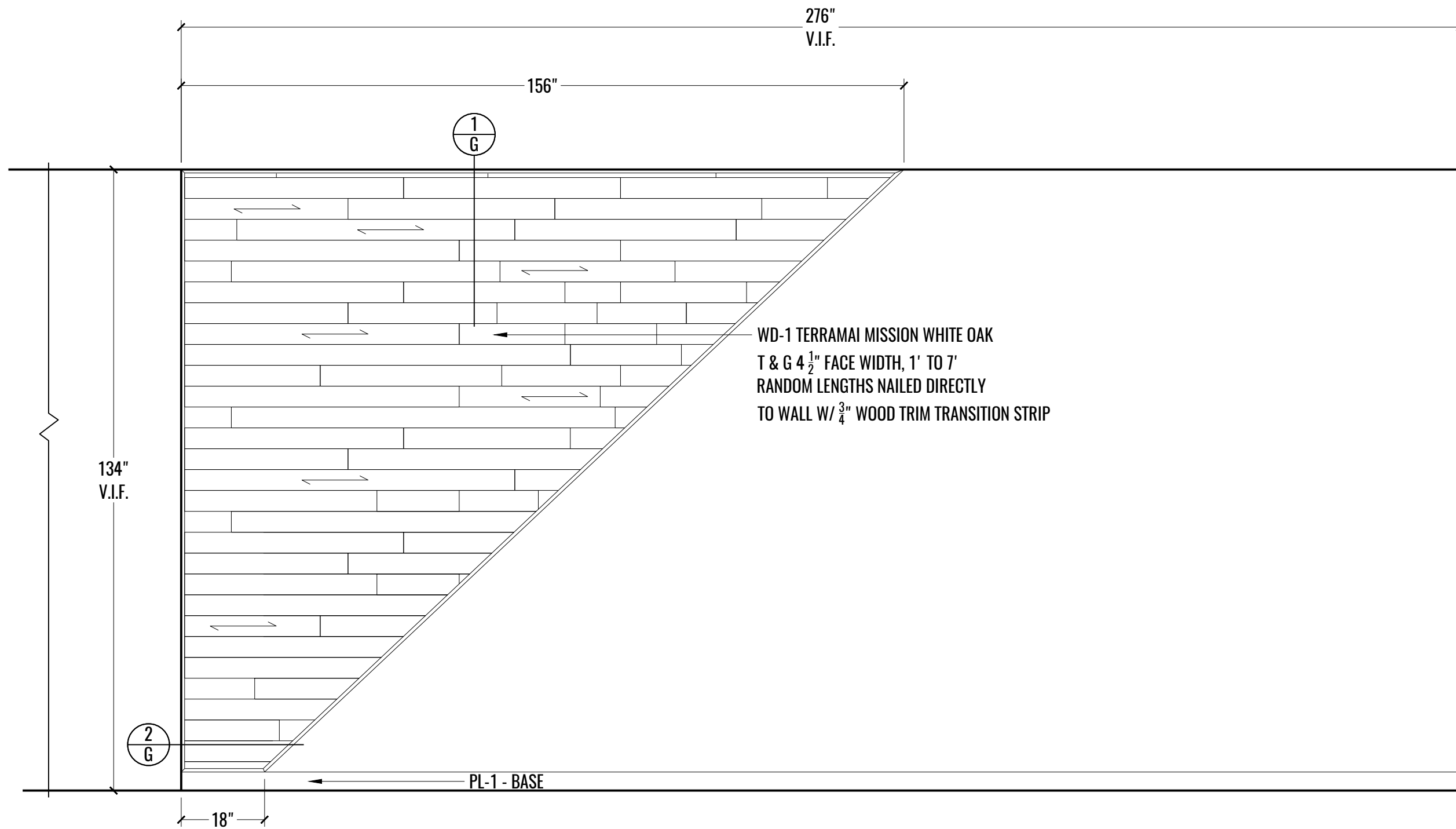

1
10 ELEVATION: WORK LOUNGE - WD-1 FEATURE WALL - 1502
SCALE: 1/2" = 1'-0"

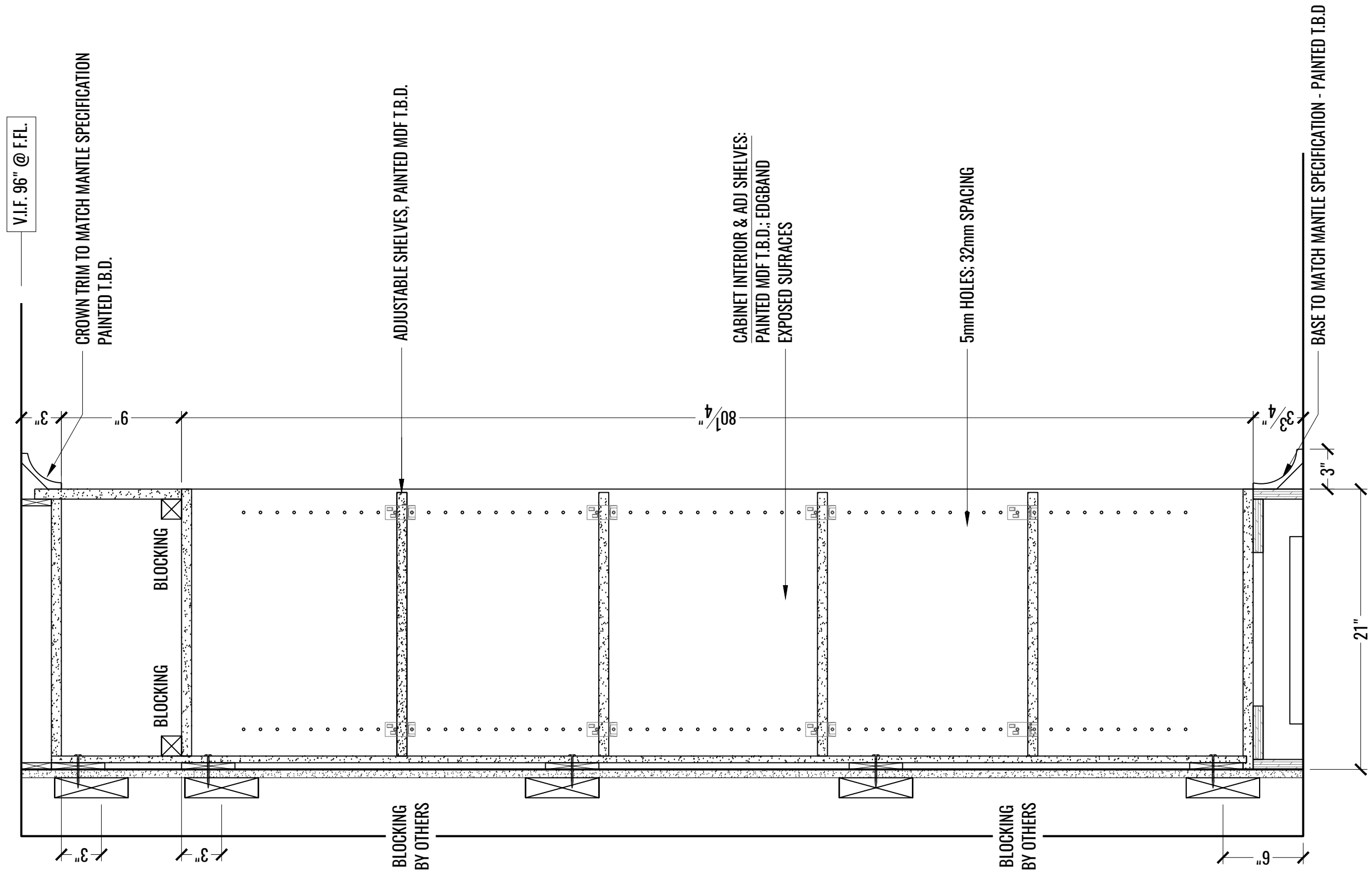

1 SECTION: BOOKSHELVES @ LIBRARY - 1510
 A SCALE: 1-1/2" = 1'-0"

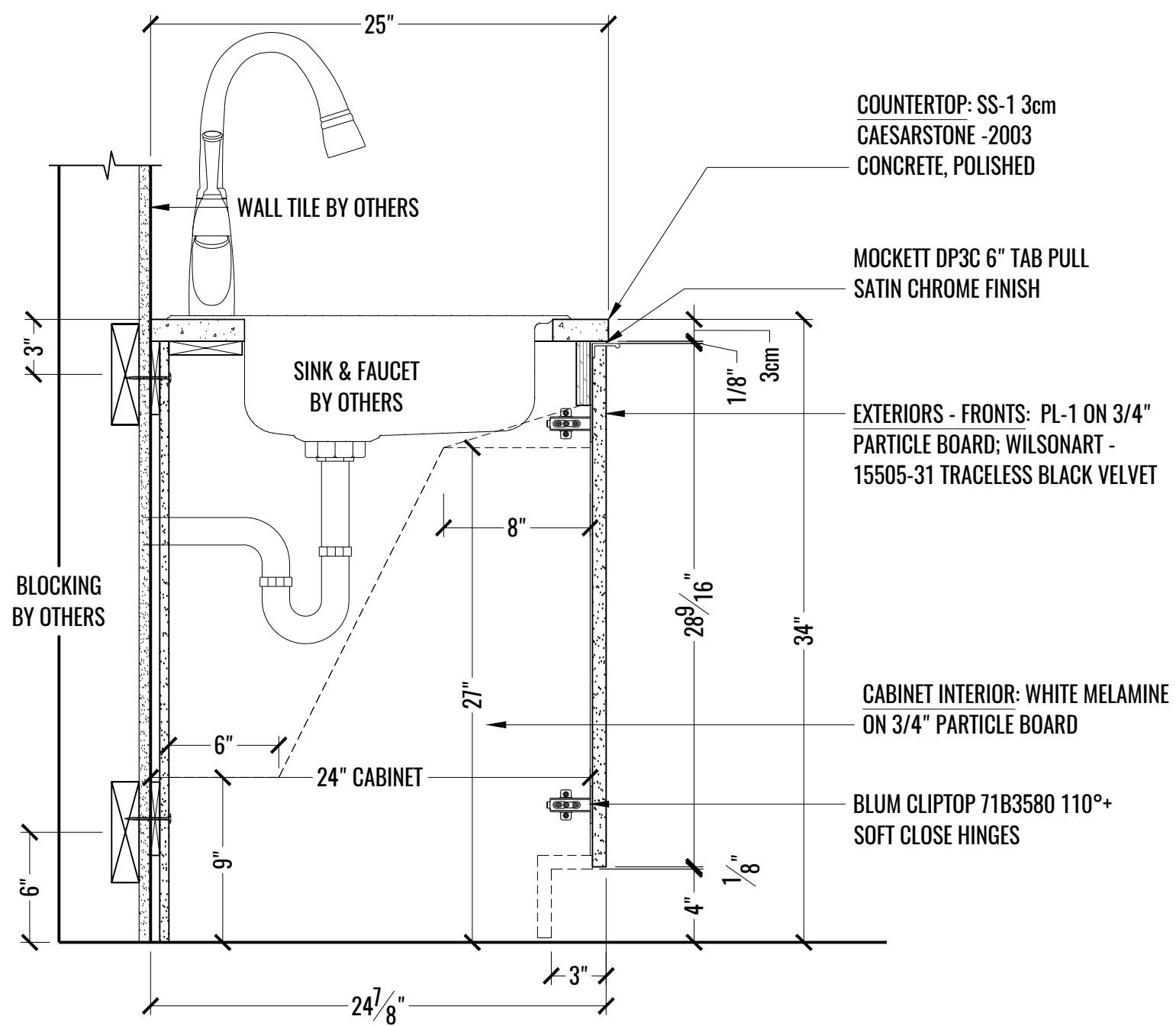

1 SECTION: SINK @ WORK LOUNGE - 1502
B SCALE: 1-1/2" = 1'-0"

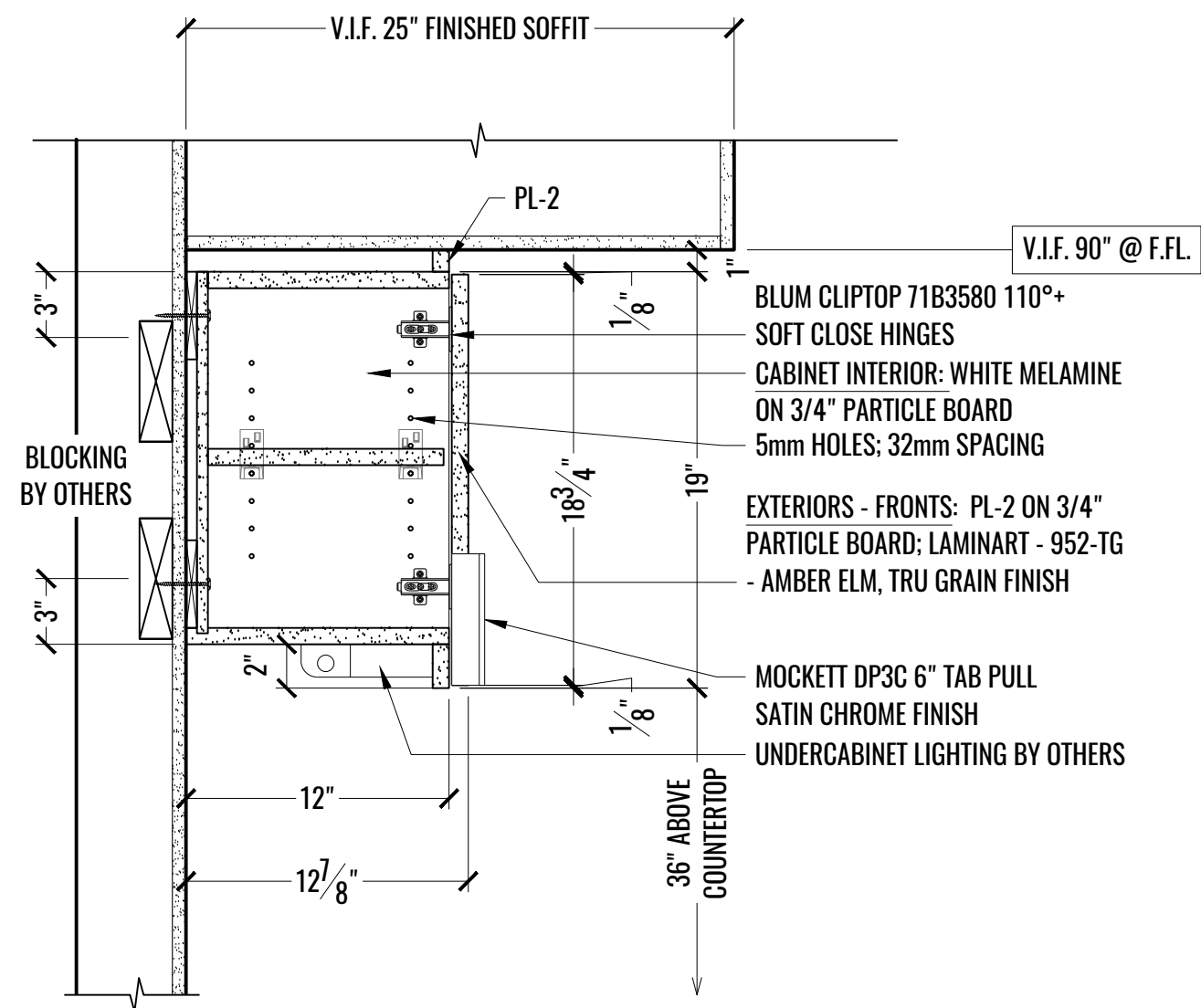

2 SECTION: UPPER CABINETS 19"H @ WORK LOUNGE 1502
B SCALE: 1-1/2" = 1'-0"

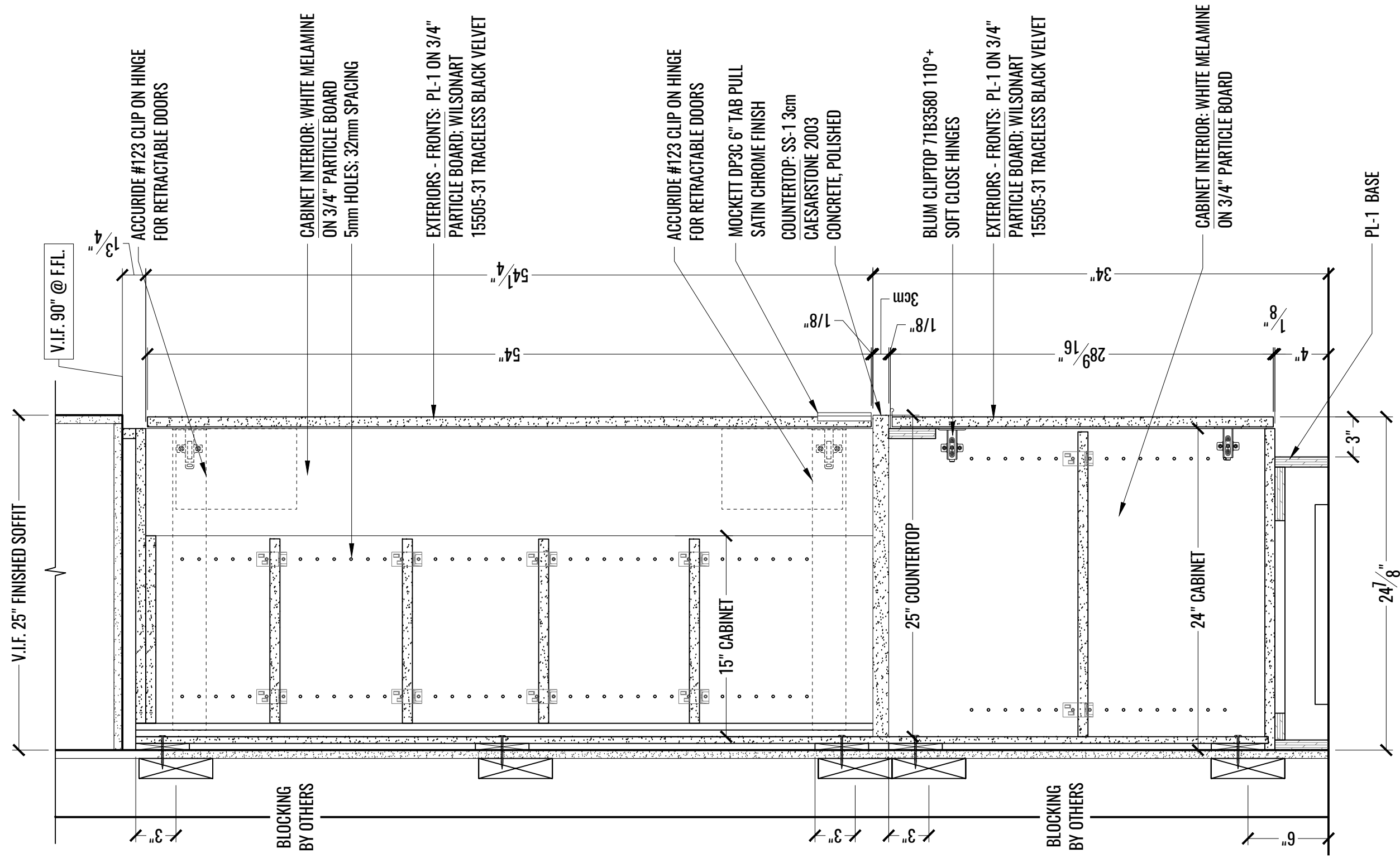

1 SECTION: TALL CABINET W/RETRACTABLE DOORS @ WORK LOUNGE - 1502

C SCALE: 1-1/2" = 1'-0"

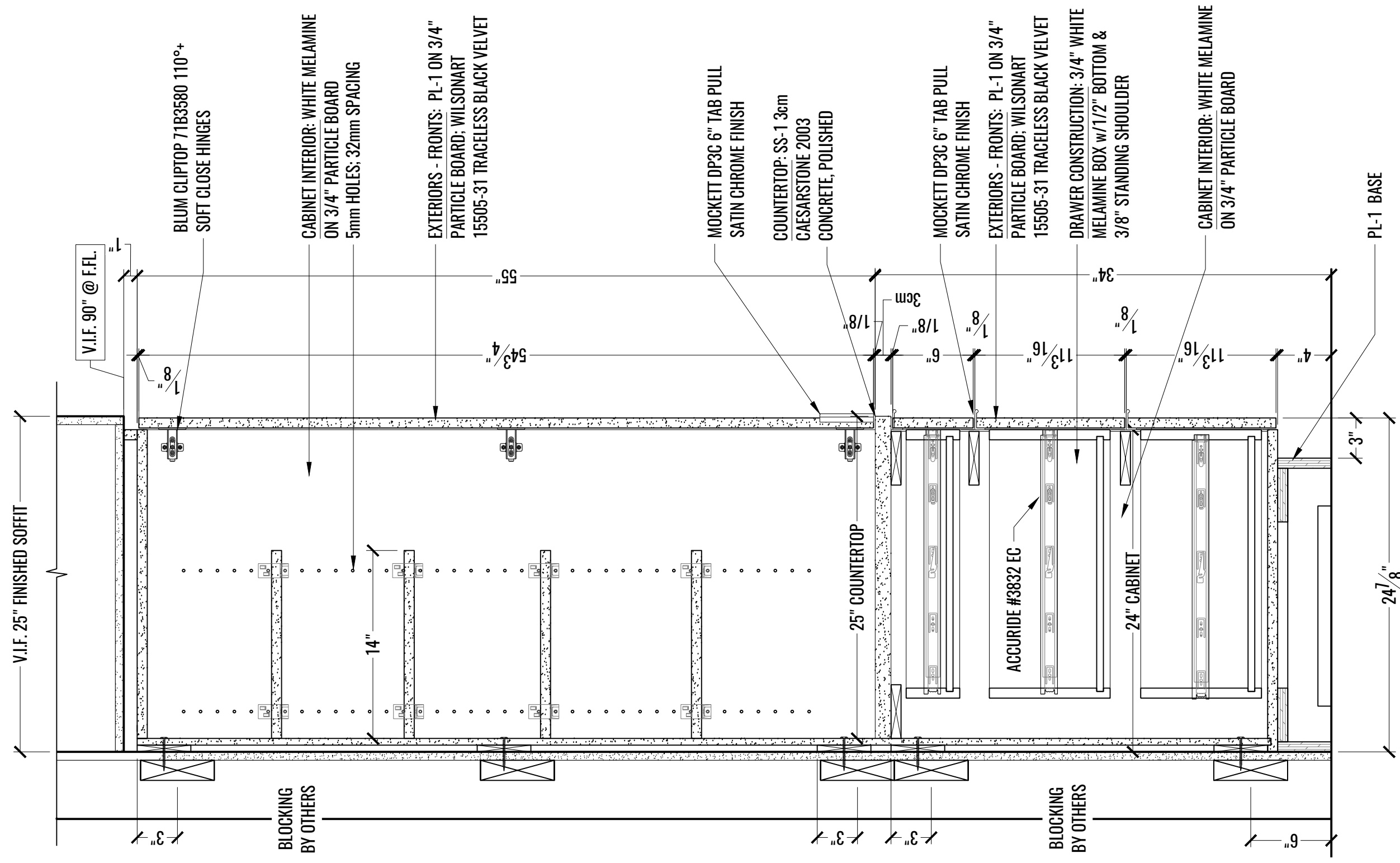

1 SECTION: TALL CABINET W/DRAWERS @ WORK LOUNGE - 1502
 D SCALE: 1-1/2" = 1'-0"

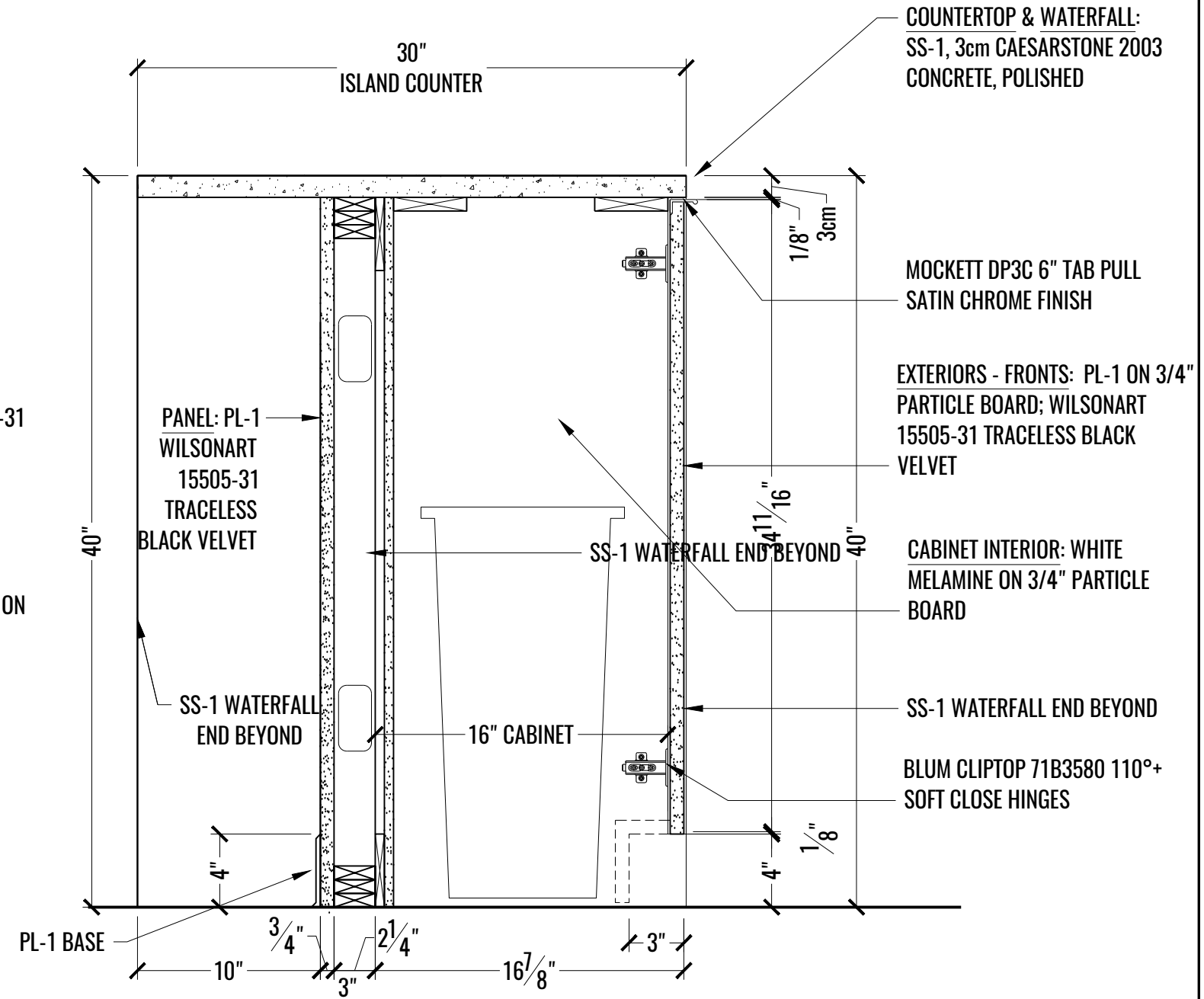
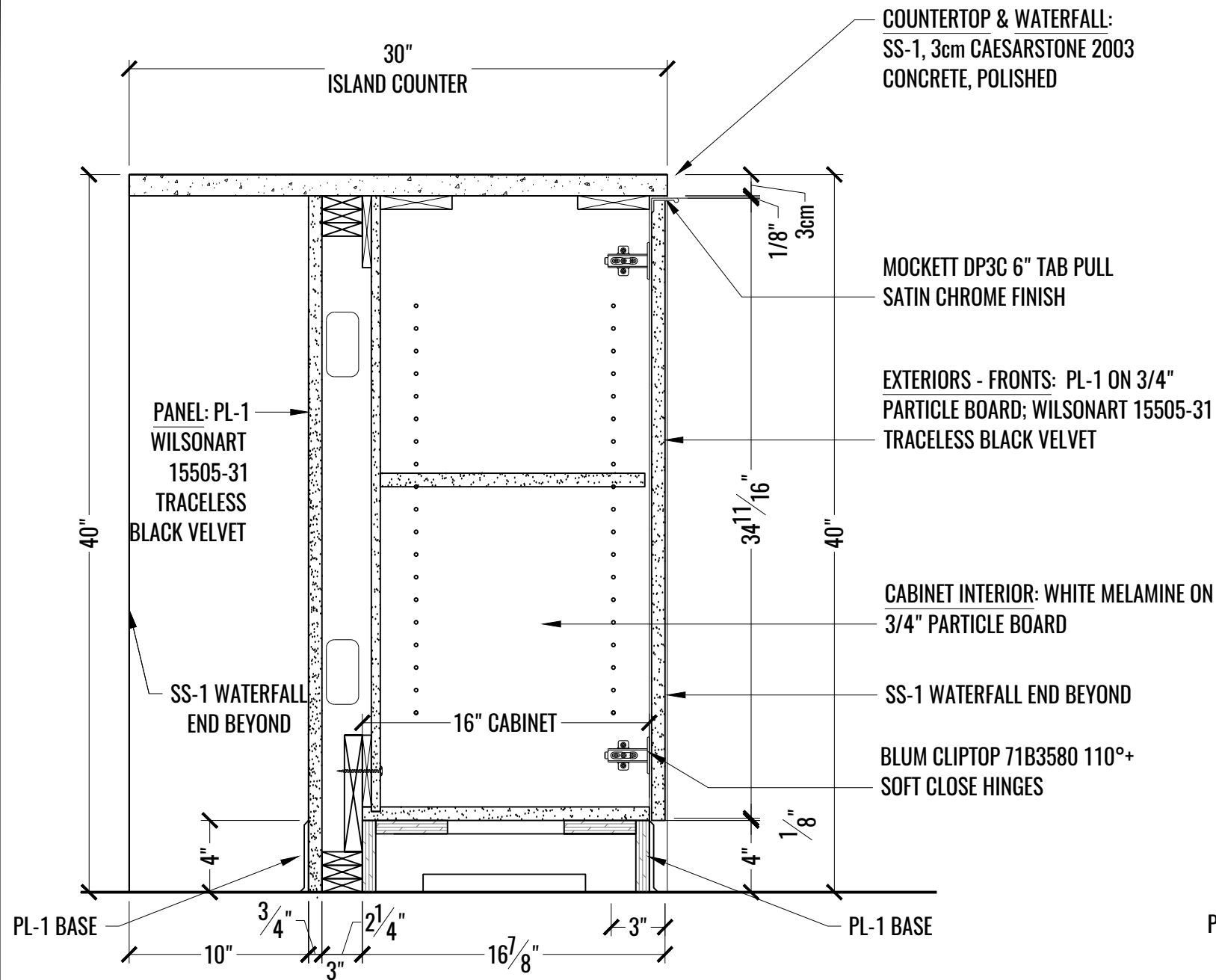

1 SECTION: BASE CABINET @ WORK LOUNGE - ISLAND - 1502
E SCALE: 1-1/2" = 1'-0"

2 SECTION: WASTE/RECYCLE CABINETS @ WORK LOUNGE - ISLAND - 1502
E SCALE: 1-1/2" = 1'-0"

COUNTERTOP & WATERFALL:
SS-1, 3cm CAESARSTONE 2003
CONCRETE, POLISHED

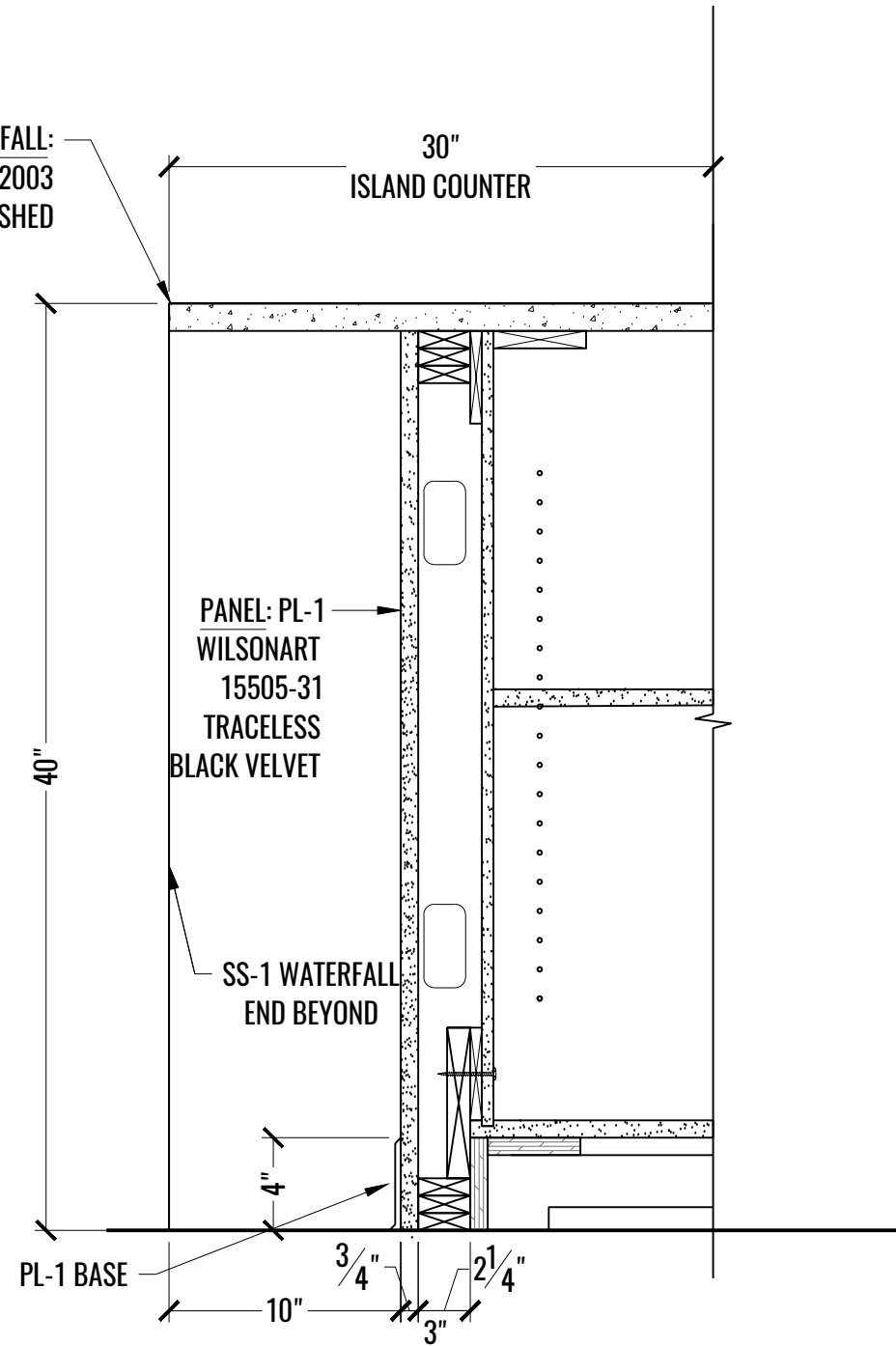

1 SECTION: BAR SEATING AREA @ WORK LOUNGE - ISLAND - 1502
F SCALE: 1-1/2" = 1'-0"

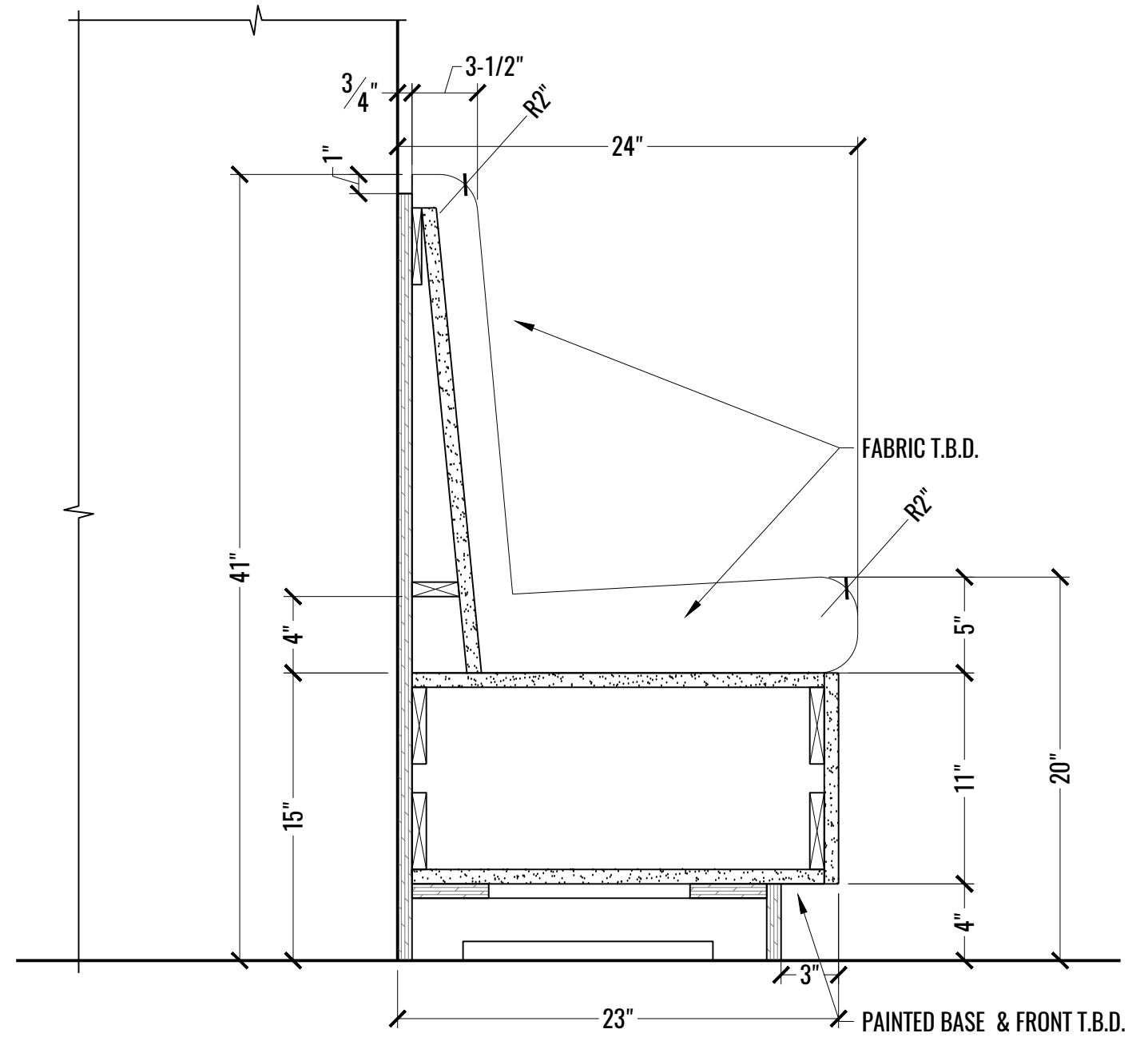

2 SECTION: BANQUETTE @ WORK LOUNGE - 1502
F SCALE: 1-1/2" = 1'-0"

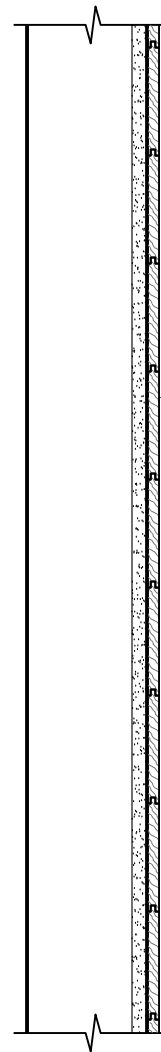

WD-1 TERRAMAI MISSION WHITE OAK
T & G 4 1/2" FACE WIDTH, 1' TO 7' (1/2" THK.)
RANDOM LENGTHS NAILED DIRECTLY
TO WALL

4 1/2"

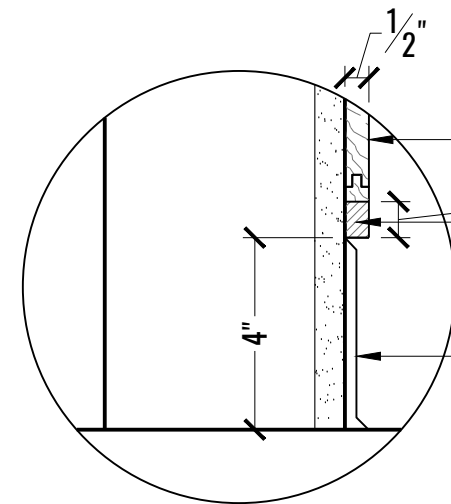

WD-1 TERRAMAI MISSION WHITE OAK & G (1/2" THK.)

WOOD TRANSITION TRIM 1/2" X 3/4" TO MATCH WD-1 FINISH

BASE PL-1

1 SECTION: WORK LOUNGE - WD-1 DETAIL - 1502
G SCALE: 1-1/2" = 1'-0"

2 SECTION: WORK LOUNGE WD-1 DETAIL @ BASE - 1502
G SCALE: 3" = 1'-0"