

CATALOGUE

MANUFACTURERS & SUPPLIERS OF

LUBRICATION & WORKSHOP
EQUIPMENT



ICTUS



ICTUS

CATALOGUE

MANUFACTURERS & SUPPLIERS OF

LUBRICATION &
WORKSHOP EQUIPMENT

Ictus has been manufacturing lubrication equipment since the early 80's. We are also the sole importers & distributors for the exclusive OMPI range from Italy. Our products are second to none & our primary focus is on you the consumer.

Our aim is to provide you with total quality & to make your bash at hand seem effortless & proficient. Our continuous commitment to innovation ensures that we are always a step ahead & that you the consumer can always be supplied with the latest & very best products available. This is the very commitment that has also ensured our substantial growth.

Our Motto:

Ora et Labora

Pray & Work



Air Operated Grease Pumps	Page 01
Ictus Platinum Series	Page 02
Hand Operated Grease Pumps	Page 03
Greasing Accessories	Page 04
Manual Oil & Fuel Dispensing Equipment	Page 05
Air Operated Oil Transfer Pumps	Page 06
Oil Dispensing Equipment	Page 07
Oil Dispensing Guns & Meters	Page 08
Oil Dispensing Accessories	Page 9
Waste Oil Evacuators	Page 10
220V - Diesel - Transfer Kits	Page 11
12 & 24 V Diesel Transfer Kits	Page 11
12V Water & Chemical Sprayers	Page 12
Electric Water Pumps	Page 12
Diesel Dispensing Equipment	Page 13
Retractable Hose Reels	Page 14
Air & Water Accessories	Page 15
Pressure Sprayers & Foamers	Page 15
Pressure Table / Notes	Page 16
Gallery	Page 17



ICT 81840A

50:1 Ratio 15/20 Kg Complete Pump + Trolley

ICT 81840

50:1 Ratio 15/20 Kg Pump Complete Excl Trolley

ICT 81818

50:1 Ratio 15/20 Kg Bare Pump



ICT 81920A

50:1 Ratio 50/60 Kg Complete Pump + Trolley

ICT 81920

50:1 Ratio 50/60 Kg Pump Complete Excl Trolley

ICT 81860

50:1 Ratio 50/60 Kg Bare Pump



ICT 81940A

50:1 Ratio 180 Kg Complete Pump + Trolley

ICT 81940

50:1 Ratio 180 Kg Pump Complete Excl Trolley

ICT 81880

50:1 Ratio 180 Kg Bare Pump

Model	81840A	81818	81920A	81860	81940	81880	81881A	81720	81715
Air Input	2-8 Bar	2-8 Bar	2-8 Bar	2-8 Bar	2-8 Bar	2-8 Bar	2-8 Bar	2-8 Bar	2-8 Bar
Ratio	50:1	50:1	50:1	50:1	50:1	50:1	100:1	30:1	90:1
Flow Rate	2900gr/min	2900gr/min	2900gr/min	2900gr/min	2900gr/min	2900gr/min	1700gr/min	15000gr/min	7000gr/min
Air Connection	F1/4"Bsp	F1/4"Bsp	F1/4"Bsp	F1/4"Bsp	F1/4"Bsp	F1/4"Bsp	F1/4"Bsp	F1/2"Bsp	F1/2"Bsp
Outlet Connection	M1/4"Bsp	M1/4"Bsp	M1/4"Bsp	M1/4"Bsp	M1/4"Bsp	M1/4"Bsp	M1/4"Bsp	M1"Bsp	M1"Bsp
Drum Capacity	15/20 Kg	15/20 Kg	50/60 Kg	50/60 Kg	180 Kg	180 Kg	180 Kg	180 Kg	180 Kg
Hose Length	3m	-	3m	-	3m	-	3m	opt	opt
Weight	15 Kg	3.8 Kg	17 Kg	5 Kg	38 Kg	7 Kg	16 Kg	18 Kg	24 Kg
Pack Dimensions	880x880x445	95x95x690	880x180x450	95x95x1005	880x870x170	880x445x170	880x445x170	350x350x1005	350x350x1005

ICT 81819A

100:1 15/20 Kg Complete

ICT 81861A

100:1 50/60 Kg Complete

ICT 81881A

100:1 180 Kg Complete



ICT 81720

30:1 180 Kg Bulk Transfer Unit



ICT 81715

90:1 180 Kg Bulk Transfer Unit

OPTIONAL:

Different length delivery hoses & quick couplers & regulators
180 Kg Lid + 150 Kg Follower Plate



ICT 80799/180 Kg

Complete Unit Incl Pump
Compacting System +
Follower Plate for Thick Grease



ICT 7-15A

60:1 Ratio 15 Kg Heavy Duty Grease Pump Complete with 3m Hose Gun Lubricator Lid + Follower Plate

ICT 7-15

60:1 Ratio Bare Pump



ICT 7-50A

60:1 Ratio 50 Kg Heavy Duty Grease Pump Complete with 3m Hose Gun Lubricator Lid + Follower Plate

ICT 7-50

60:1 Ratio Bare Pump



ICT 7-180A

60:1 Ratio 180 Kg Complete with 3m Hose, Gun, Swivel, Lubricator, Lid + Follower Plate

ICT7-180

60:1 Ratio Bare Pump

Optional: 180kg Trolley ICT88 (Page 9)



ICT 745-15

45:1 Ratio 50 Kg Lube Free Grease Pump

Optional: 3m Hose, Gun, Swivel Lid & Follower Plate Available in 50 and 180 Kg

Model	ICT7-15A	ICT7-50A	ICT7-180A	ICT745	ICT931
Air Input	3-8 Bar	3-8 Bar	3-8 Bar	3-8 Bar	3-8 Bar
Ratio	60:1	60:1	60:1	45:1	2,7:1
Flow Rate	700 gr/min	700 gr/min	700 gr/min	450 gr/min	16 Lt/min
Max Output Pressure	414 Bar	414 Bar	414 Bar	360 Bar	19 Bar
Air Consumption	0,3m3/mm	0,3m3/mm	0,3m3/mm	0,3m3/mm	0,3m3/mm
Air Connection	F1/4"Bsp	F1/4"Bsp	F1/4"Bsp	F1/4"Bsp	F1/4"Bsp
Max Outlet Connection	M1/4"Bsp	M1/4"Bsp	M1/4"Bsp	M1/4"Bsp	M1/2"Bsp
Drum Capacity	15 Kg	50 Kg	180 Kg	15/50/180 Kg	200Lt
Hose Length	3m	3m	3m	3m	Optional
Weight	9,9 Kg	128 Kg	17 Kg	15 Kg 11.7	7 Kg
Pack Dimensions	340x340x630	420x400x950	680x680x1185	300x340x630	1180x150x150



ICT 7C1 15-18 Kg

ICT 7C2 50 Kg

Ratio 15-18 Kg Complete with Roller Cart



ICT 7 T1
15-18 Kg

ICT 7 T2
50 Kg



ICT 9A Stub

ICT 9 Standard



5:1 Ratio heavy duty Ictus oil transfer pump ideal for lube installations & long distance pumping

- Input air pressure 3-8 Bar
 - Output pressure 7Bar in equals 35Bar out
 - Flow rate 16L/min
 - Air connection F/M 1/4"Bsp
 - Outlet connection F/M 1/2"Bsp
 - Weight
- ICT 9 Standard : 10 Kg
 ICT 9 Stub : 11,2 Kg
 Incl Bracket & 1" x 2m Hose
- Pack Dimensions
- ICT 9 Standard : 1180 x 150 x 150
 ICT 9 Stub : 670 x 150 x 150



ICT 931

2,7:1 Ratio Lube Free Oil Transfer Pump

- Suitable for 210L Drums



- ICT 19**
500Gram Hand Lever
- Complete with rigid tube & Hydraulic coupler
 - Optional flex hoses (see page 4)
 - Weight 1,25 Kg
 - Pack Dimensions 415x135x65



- ICT 80900**
1000Gram
- Air operated grease gun with flex hose & Hydraulic coupler
 - Optional flex hoses (see page 4)
 - Weight 2,0 Kg
 - Pack Dimensions 425x150x80



- ICT 500G**
Cartridge
- Prepacked grease cartridges (24per case)
 - Fits ICT 19
 - Weight 1,25 Kg
 - Pack Dimensions
 - Fill to Customer Requirements



- ICT 80250**
15 Kg Spring Loaded, Light Duty Field Greaser
- Complete with Drum, Cover & Follower Plate & 1.5m Hose & Coupler
- Delivery volume 2.8gram/stroke
 - Develops pressure upto 300Bar (30mPa)
 - Weight 5.5 Kg
 - Pack Dimensions 340x490x630
 - Available in 18 Kg ICT 8025018



- ICT 84000**
15 Kg Bucket Greaser, Light Duty
- Complete with Follower Plate & 1.5m hose & coupler
- Delivery volume 2.8gram/stroke
 - Develops pressure upto 300Bar (30mPa)
 - Weight 6.5 Kg
 - Pack Dimensions 250x500x650



- ICT 4HD0012**
10 Kg Foot Pump
- Complete with 2m hose & coupler
- Delivery volume 3.3gram/stroke
 - Develops pressure upto 420Bar (42mPa)
 - Weight 12.9 Kg
 - Pack Dimensions 460x460x525



- ICT1 Platinum Series**
5 Kg Mini Greaser
- Complete with Drum, 1.5m Hose, Coupler & Follower Plate
- Delivery: 3.0gram/stroke
 - Pressure upto 320Bar
 - Weight 4,2 Kg
 - Pack Dimensions 520x355x355



- ICT2 Platinum Series**
15 Kg Heavy Duty Grease Pump
- Complete with Lid, Follower Plate, 1,5m Discharge Hose, Coupler and Follower Plate
- Delivery: 3.0gram/stroke
 - Pressure upto 320Bar
 - Weight 4 Kg
 - Pack Dimensions 600x600x400



- ICT3 Platinum Series**
16 Kg Heavy Duty Grease Pump
- Complete with Lid, Follower Plate & Drum 1,5m Discharge Hose & Coupler
- Delivery: 3.0gram/stroke
 - Pressure upto 320Bar
 - Weight 6,5 Kg
 - Pack Dimensions 650x500x250



ICT 18R

Grease Control Gun

- Steel body with rigid tube & hydraulic coupler
- 1/4" Male Entry
- Weight 0,70 Kg
- Pack Dimensions 215x185x35



ICT 18F

Grease Control Gun

- Steel body with flexible hose & hydraulic coupler
- 1/4" Male Entry
- Weight 0,70 Kg
- Pack Dimensions 215x185x35



ICT 20

Z Swivel

- 1/4M-FM" Bsp connected between hose & gun
- Allows complete single axis rotation
- Weight 0,35 Kg
- Pack Dimensions 72x70x30



ICT 20-1

Straight Swivel

- M/F 1/4"Bsp connected between hose & gun
- Allows complete single axis rotation



ICT 88300

Digital Greaser Meter

- Complete with grease control
- M/F 1/4"Bsp entry
- Flow rate: 0.2Kg - 2 Kg
- Accuracy +/- 0.3%
- Weight 1.4 Kg
- Pack Dimensions 300x200x50



ICT 88360

Preset Digital Greaser Meter

- Complete with grease control
- M/F 1/4"Bsp entry
- Flow rate: 0.2 Kg - 2 Kg
- Accuracy +/- 0.5%
- Min. preset volume: 0.010 Kg
- Max, preset batch: 9999 Kg
- Weight 1.7 Kg
- Pack Dimensions 300x200x50

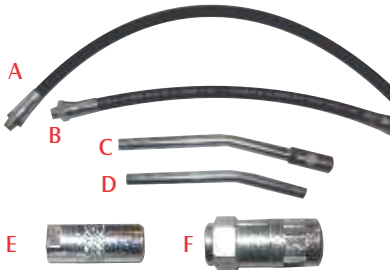

- A 1/8 - 1/8 Flex Hose Available 8",12",18"
- B 1/8 - 1/8 Flex Hose with 3 Jaw
- C 1/8 - 1/8 Rigid Tube with Coupler
- D 1/8 - 1/8 Rigid Tube
- E ICT21 Light Duty Coupler 3 or 4 Jaw
- F ICT22 Heavy Duty Coupler 3 Jaw



ICT 110A

Metric Nipple Kit

ICT 110B

Imperial Nipple Kit

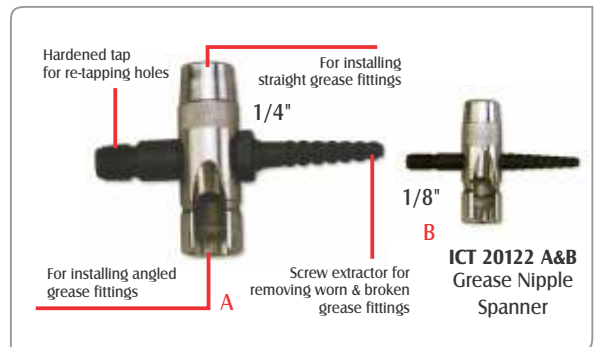

FOLLOWER PLATES & HOSES

Rubber Follower Plates

- 15 Kg ICT 73
- 50 Kg ICT 77
- 180 Kg ICT 80



Hose Lengths for Grease

- From 1m - 20m
- 1/4" - 1/4" for ICT 7 / 1/4" - 1/8" ICT 1/2/3



ICT 2130

One Man Operation Coupler

Can be Screwed onto the Front of the Discharge Hose, Connect to grease nipple & Pump.
No more holding hose coupler onto Grease Nipple.

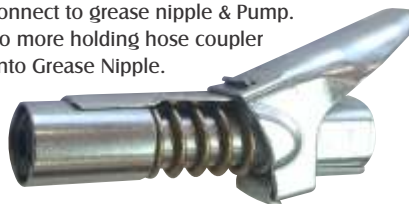

ICT 47702

1/8 Bspm Grease Feeder

- Fits directly onto bearing 1/8"BSP
- Bowl Capacity 170 grams
- Material Polycarbonate
- For use of Grease NLGI 0 to 4





- Diesel
- Paraffin
- Oil

ICT 16
Rotary Hand Pump
 Fits 15/50 & 210 Liter Drums
Optional:
 Discharge Hose
 • Flow Rate 20L p/min
 • Weight 1,8 Kg
 • Diesel Oils, Lube Oil
 • Pack Dimensions 250x250x300



- Chemicals
- Petrol

ICT 16 PT
Propylene Rotary Hand Pump
 Fits 15/50 & 210 Liter Drums
Optional:
 Discharge Hose
 • Flow Rate 20L p/min
 • Weight 2,3 Kg
 • Diesel Oils, Lube Oil
 • Pack Dimensions 250x250x300

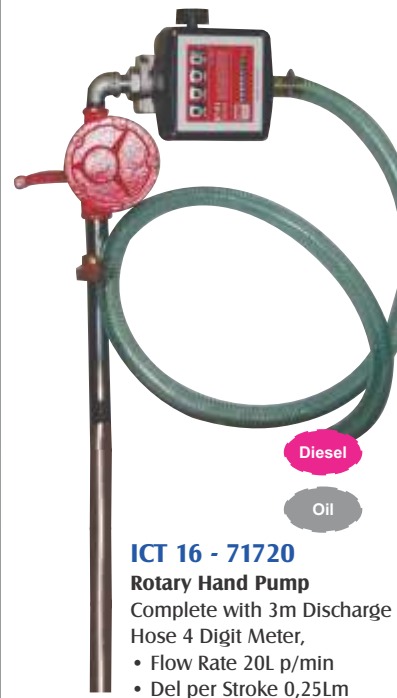

- Diesel
- Oil

ICT 16 - 71720
Rotary Hand Pump
 Complete with 3m Discharge Hose 4 Digit Meter,
 • Flow Rate 20L p/min
 • Del per Stroke 0,25Lm
 • Weight 7 Kg
 • Pack Dimensions 275x250x1300

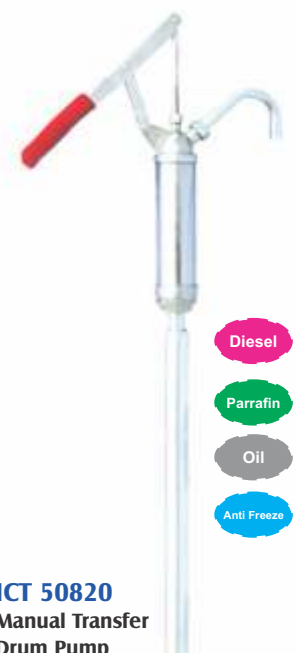

- Diesel
- Paraffin
- Oil
- Anti Freeze

ICT 50820
Manual Transfer Drum Pump
 • Flow Rate 8L p/min
 • Del per Stroke 0,13Lm
 • Weight 2 Kg
 • Pack Dimensions 80x80x135



ICT 100K0
 Model: 1/2" ICT00K0
 L/pm: 11,5L/m
 Delivery: 25m
 Weight: 5.1 Kg
 Ideal for clear light liquids & oils



ICT 100K2
 Model: 1"
 L/pm: 23L/m
 Delivery: 25m
 Weight: 8.7 Kg



ICT 50400
16L Hand Pump with 1.5 Hose & Goose Neck
 • Flow rate 8L/min
 • Delivery 0.13L
 • Weight 7.3 Kg
 • Pack Dimensions 250x320x600



ICT 6 PC
16L Semi Rotary Heavy Duty Gear Pump
 Complete with 2m Hose & Goose Neck for Gear Oil
 • Flow rate adjustable stroke, 250mL/turn
 • Weight 5,15 Kg
 • Pack Dimensions 345x235x1280
 • Weight 7 kg
 • Pack Dimensions 345x235x1280



- Petrol
- Detergents
- Lubricants
- Oil
- Anti Freeze

ICT 04921
3 Piece Telescopic Drum Pump
 Fit 15/50 & 180 Kg Containers
 Smooth Operation
 Delivert 30 L/min
 Weight 5 Kgs
 Pack Dimensions 300X300X1350

**ICT 31247/L****1:1 Ratio oil transfer pump**

- Output pressure 9Bar
- Flow rate 35L/min
- Air connection F $\frac{1}{4}$ "Bsp
- Outlet connection M $\frac{3}{4}$ "Bsp
- Weight 7 Kg
- Pack Dimensions 95x95x1180

**ICT 31248****1:1 Ratio Anti Freez oil transfer pump**

- Output pressure 9Bar
- Flow rate 35L/min
- Air connection F $\frac{1}{4}$ "Bsp
- Outlet connection M $\frac{3}{4}$ "Bsp
- Weight 5 Kg
- Pack Dimensions 110x110x530

**ICT 31242 Kit****3:1 Ratio oil transfer kit**

- Output pressure 18.5Bar
- Flow rate 16L/min
- Air connection F $\frac{1}{4}$ "Bsp
- Outlet connection M $\frac{1}{2}$ "Bsp
- Weight 8 Kg
- Pack Dimensions 95x95x530

**ICT 31231****3:1 Ratio oil transfer pump**

- Output pressure 21Bar
- Flow rate 16L/min
- Air connection F $\frac{1}{4}$ "Bsp
- Outlet connection M $\frac{1}{2}$ "Bsp
- Weight 6 Kg
- Pack Dimensions 95x95x1270

**ICT 31240****5:1 Ratio wall mount oil transfer pump 1 reel for long distance pumps with probe**

- Output pressure 30Bar
- Flow rate 12L/min
- Air connection F $\frac{1}{4}$ "Bsp
- Outlet connection M $\frac{1}{2}$ "Bsp
- Weight 8.2 Kg
- Pack Dimensions 95x95x1270

**ICT 31250****5:1 Ratio for 210L drum including bung adaptor**

- Output pressure
- Flow rate
- Air connection
- Outlet connectionp
- Weight 5.8 Kg
- Pack Dimensions 95x95x1270

**ICT 32135****1,5:1 Ratio**

- Flow rate 122L/min
- Output pressure 12 Bar
- Air Consumption 1,92mc/l
- Fluid Outlets F1:Bsp
- Air Inlet F 1/2" Bsp
- Weight 21 Kg
- Pack Dimensions 95x95x1200

**ICT 31256 EVO****6:1 Ratio**

- Output pressure 48Bar
- Flow rate 32L/min
- Air connection F1/2"Bsp
- Outlet connection M3/4"Bsp
- Weight 12 Kg
- Pack Dimensions 95x95x1270



ICT 98208 Kit
1000L Flow Bin Complete with 3:1 Pump, 3m Hose, Digital Meter & Gun



ICT 98250 1000L Kit
Complete 15m reel, 3:1 ratio, connection hose, meter gun & 1000L flow bin
• Weight 70 Kg
• Pack Dimensions 1100x1100x1400



ICT 31240 kit
15m 1/2" Hose Reel
5:1 ratio, 3m connection hose, pump, digital meter gun
• Weight 42 Kg
• Pack Dimensions 790x900x1400



ICT 80793
Mobile Kit with Hose Reel
3:1 Ratio oil pump complete with 15m 1/2" hose reel oil control gun, digital meter & 3m connection hose gun & meter & trolley
• Weight 62 Kg
• Pack Dimensions 790x900x1400

• Available in Grease Version ICT 81940-1R



ICT 23620
Wall Mounted Oil Bar Kit
• 2x 1:1 Ratio oil pump & hoses
• 2x Digital meters
• Double oil bar bracket
• 2x Safety dispensing cock
Single bar kit available ICT 23020

ICT 80794
Mobile Kit
3:1 Ratio, oil pump 3m hose digital meter, hose, meter gun & 180 Kg Trolley
• Weight 42 Kg
• Pack Dimensions 790x900x1400





ICT 14236

- 1/2" Oil gun with rigid tube & non-drip nozzle
- Weight 0,90kg
- Packing Dimensions 310x165x55



ICT 14201

- 1/2" Oil gun with 90° flex hose & non-drip nozzle
- Weight 0,90kg
- Packing Dimensions 310x165x55



ICT 30

- 1/2" BSP oil gun with flex hose & non-drip nozzle
- Weight 0,85kg
- Packing Dimensions 310x165x55



ICT 71740

- High volume digital meter & oil gun 1" BSP
- Flow rate 20L/min - 70L/min
- Pressure 40Bar max
- Accuracy ±0.5%
- Weight 4 Kg
- Packing Dimensions 380x200x100



ICT 14300

- High volume 1" BSP oil flow gun with 3/4" BSP flex hose & non-drip nozzle
- Delivery 60L/min
- Weight 1 kg
- Packing Dimensions 310x165x55



ICT 15842

- Preset digital meter & oil gun
- Flow rate 2L/min - 20L/min
- Pressure 1 - 40Bar
- Accuracy ±0.5%
- Weight 1.5 Kg
- Packing Dimensions 380x200x100



ICT 15867

- Mechanical analogue meter & gun for Oil & Ant-Freeze
- Connection 1/2" Bsp
- Flow Rate 15 L/min
- Pressure 70Bar



ICT 2830

- Digital meter oil gun 1/2" BSP
- Flow rate 30 L/min
- Pressure Max 70Bar
- Accuracy
- Weight 1,3 Kg
- Packing Dimensions 330x175x60



ICT 15892

- Digital oil meter & gun 16Ø
- Flow rate 1L/min - 20L/min
- Pressure 1-50Bar
- Accuracy ±0.5%
- Weight 3,7 Kg
- Packing Dimensions 380x200x100



Oil

ICT 15863

- Mechanical Analogue Meter
- Connections 1/2" Bsp
- Flow rate 15L/min
- Pressure Max 70 Bar
- Accuracy +- 0,5%



Oil

Diesel

Anti Freeze

ICT 28

- Digital flow meter 1/2" BSP
- For Oil, Diesel & Anti Freeze
- Flow rate 30L/min
- Pressure Max 70 Bar
- Weight 1,3 Kg
- Packing Dimensions 100x90x65



Oil

ICT 15898

- Digital meter
- Flow rate 1L/min - 20L/min
- Viscosity Sae 5 - 240
- 1/2" Male
- Accuracy ±0.5%
- Weight 0.7 Kg
- Packing Dimensions 100x100x100



- Diesel
- Petrol
- Oil
- Veg Oil

ICT 70500

1" BSP inline oil filter

- | | | | | |
|-------------|---------|---------|----------|----------|
| • Flow rate | 60L/min | 90L/min | 100L/min | 100L/min |
| • Type | paper | paper | paper | paper |



ICT 70501

1" BSP inline oil filter

- Flow rate 45L/min
- 30 Micron



ICT 31242

Wall Mount Bracket



ICT 22071

Suction Probe for 210L Drum Non-Return Valve & Bung Adaptor Included

Optional:
1"x 1,5m Suction Hose



ICT 40450
Manual Oil Dispenser

ICT 2360
Oil Bar for 210L drums



ICT 2361

Oil Bar for 210L drums, complete with 3:1 ratio oil pump, meter, hose & regulator



Pouring Jug
1L / 2L / 5L



Funnels
180mm / 200mm

ICT 193 -2 / ICT 193-4
Spill Decks,

2 & 4 Drum Units

2 Drum 600x1200 63 Kg
4 Drum 1200x1200 107 Kg



ICT 49720

Reel & Drum Stand

2x 15m Oil Hose Reels, Guns
Meters 2x3:1 Oil Pumps
Drum Stand & Drip Base



ICT2300-1

Wall-mounted dispensing bar, suitable for oil and antifreeze, quipped with 1 spring operated spigot with splash guard filter and drain valve for drop tray. Connections BSP (F). Unit is prepared for the installation of 2 more spigots.

Optional:

ICT 2300-2 2 Spigot / ICT 2300-3 3 Spigot

ICT88

210 Drum Trolley





ICT 40015

- 1/2"
- Max Head 84m
- Max Flow Rate 57L/min
- Max Particle Ø 2.5mm
- Suction & Discharge Size 1/2"
- Air Inlet Port 1/4" Bsp
- Max Air Input 8.4Bar
- Weight 5kg
- Pack Dimensions 290x200x350

1/2" Double Diaphragm Pump



ICT 40025-1

- 1"
- Max Head 84m
- Max Flow Rate 157L/min
- Max Particle Ø 4mm
- Suction & Discharge Size 1"
- Air Inlet Port 1/2" Bsp
- Max Air Input 8.4Bar
- Weight 10kg
- Pack Dimensions 340x250x490

1" Double Diaphragm Pump



ICT 40050-2

- 2"
- Max Flow Rate 587L/min
- Max Particle Ø 8mm
- Suction & Discharge Size 2"
- Max Air Input 8.4Bar
- Weight 24 Kgs
- Pack Dimensions 500x350x740



ICT 3244

Wall mounted drain assembly

- 10L Swivel basin
- 1:1 Ratio air pump for waste oil



ICT 90120

Wheeled oil drain for under body waste oil

- Capacity 110L
- Attaching connection F1/2" Bsp
- Weight 26Kg
- Pack Dimensions 800x560x180



ICT 90124-A

Wheeled oil drain for waste oil including air operated discharge pump from drain

- Capacity 70L
- Attaching connection F3/8" Bsp
- Flow rate 22L/min
- Output pressure 4Bar
- Weight 34Kg
- Pack Dimensions 800x560x180

Also Available Excl Pump ICT90124



ICT 71476 KIT
Diesel pump with meter & 3/4" BSP hose x 4m & diesel nozzle

- Flow rate 50L/min
- Voltage 220V
- Weight 20 Kg
- Pack Dimensions 430x355x330



ICT 71479 KIT
Diesel oil pump with meter & 1" 10m retractable hose reel complete with diesel gun

- Flow rate 50L/min
- Voltage 220V
- Inlet connection 1"
- Weight 49 Kg
- Pack Dimensions 325x620x500



ICT 71900-1 Kit
Self priming vein pump for diesel with bypass valve

- Flow rate 60L/min
- Voltage 220V
- Max. Pressure 5Bar
- 1" connection ports
- Weight 15 Kg
- Complete with 4m Discharge Hose & Autoflow
- Pack Dimensions 570x430x220



ICT 71900
Self priming vein pump for diesel

- Flow rate 70 - 90L/min
- Voltage 220V
- Max. Pressure 2Bar
- 1" connection ports
- Weight 9 Kg
- Pack Dimensions 290x190x210

Optional

- Suction Pipe for 210 Drum ICT22072 (Page 9)
- 1" meter ICT 71721 (Page 13)
- 1.5 meter Discharge Hose & Gun ICT 71400 / 71490 (Page 13)



12 & 24 V DIESEL TRANSFER KITS



ICT 70495 KIT
Portable diesel transfer pump complete with 5m hose, diesel gun & fitting

- Flow rate 40L/min
- Voltage 12V 70495 / 24V 70495-1
- Weight 9 Kg
- Pack Dimensions 435x355x320



ICT 122437
12V Diesel pump set with diesel meter, 4m hose & auto gun

- Flow rate 40L/min



ICT 852000
12 V Bi Pump

- Flow Rate 60L/min
- Cable Connectors 4m

Optional:

- Hose + Nozzle ICT 71490
- Packaging Dimensions 290x190x250
- Handles wide Range of Fluid Viscosities



ICT 8851
12 V Barrel Pump for 210L Drums
 Ideal for Medium Diesel

- Flow Rate 80 L/min



ICT SP55R1

55L 12V Sprayer

- Self priming pump
- 2.6L/min Open flow 50Psi
- Spray gun with 550mm stainless steel lance
- 6m Delivery hose
- 3m Battery cable
- Constant flow no pump pulsation
- Weight 8 Kg
- packaging dimensions 715x125x360



ICT WP50M1

100L 12V Sprayer

- 12V Non hazardous chemical pump
- 5.3L/min Open flow
- Lock on trigger for continuous spraying
- 3m wiring harness
- 4m 3/4" Delivery hose
- Weight 10 Kg
- packaging dimensions 800x475x395



ELECTRIC OIL PUMPS



ICT 38021

380V

ICT 52522

525V

380V & 525V Electric oils & diesel transfer pumps
 Flow rates from 18 - 70L/min
 Distances up to 2 Kms
 Pump can be connected in tandem series
 made to specifications required



ICT 71478

Self priming pump Gear Pump for Oil

- Flow rate 25L/min
- Voltage 220V
- Max pressure 6Bar
- 1" connection ports
- Weight 13 Kg
- Pack dimensions 360x210x270

Optional:

- Suction probe ICT 22072 (Page 9)
- Meter ICT 71721 (Page 13)
- Delivery hose 5m & gun ICT 71400 or 71490 (Page 13)





Diesel

ICT 7173C

3 Digit meter

- Parts 1" Flanged
- Min Flowrate 20L/m
- Max Pressure 10Bar
- For Diesel
- Gravity Yes
- Calibratory Yes
- Packaging Dimension 220x150x220
- Weight: 2,2 Kg



Diesel

ICT 7174C

4 Digit meter

- Parts 1" Flanged
- Min Flowrate 20L/m
- Max Pressure 10Bar
- For Diesel
- Gravity Yes
- Calibratory Yes
- Packaging Dimension 220x150x220
- Weight: 2,2 Kg



Diesel

ICT 71721

4 Digit mechanical diesel / oil meter

- Flow rate 20-120L/min
- Max Pressure: 3,5 Bar
- Ports 1" female
- Resettable
- Weight 1.3 Kg
- Pack Dimensions 310x310x200



ICT 71400

Diesel / oil gun 1" BSP swivel connection

- Flow rate 60L/min
- Weight 0,95 Kg
- Pack Dimensions 405x190x55

Optional

- 5m Diesel Hose 1" open end ICT 199



ICT 71490

Diesel / oil gun 1" BSP swivel connection with auto stop

- Flow rate 110L/min
- Weight 1,7 Kg
- Pack Dimensions 405x190x55

Optional

- 5m 1" Male to 1" Male Swivel ICT 198



Diesel

ICT 1224/24

Digital Diesel flow meter

- Inlet connection 1" NPT
- Outlet connection 1" Bsp
- Pressure 10Bar



ICT 71490

Diesel / oil gun 3/4" BSP swivel connection with auto stop

- Flow rate 60L/min
- Weight 1,7 Kg
- Pack Dimensions 405x190x55

Optional

- 5m 3/4" Male to 3/4" Male Swivel Hose ICT 198



ICT 1609TP

Diesel / oil gun 1" Inlet

- Flow rate 80L/min
- Built in Flow Meter
- Pack Dimensions 405x190x55



CAM LOCK FITTINGS

Available

- 1/2" to 1.5" cam couplers
- 1/2" to 1.5" cam adaptors
- 1/2" to 1.5" dust covers



ICT 37120
Spring driven bare hose reel with adjustable arms ideal for 20m 1/2" hose for oil

- Optional swivel bracket 39502
- Max pressure 600 Bar
- Inlet M1/2" Bsp outlet F1/2" Bsp
- Hose 1/2" Bsp
- Max hose length 20m excl. hose
- Weight 18 Kg bare
- Pack Dimensions 260x550x450



ICT 39502



ICT 36470
Spring driven bare hose reel with adjustable arms ideal for 1/2" hose 35m for oil

- Optional swivel bracket 39505
- Max pressure 200 Bar
- Inlet M1/2" Bsp outlet F1/2" Bsp
- Hose 1/2" Bsp
- Max hose length 35m
- Weight 26 Kg bare
- Pack Dimensions 260x590x600



ICT 39505



ICT 36216
Spring driven bare hose reel with adjustable arms ideal for 1" 10m hose for oil / diesel 17m 3/4" hose

- Optional swivel bracket 36220
- Max pressure 20 Bar
- Inlet M1" Bsp outlet F1" Bsp
- Hose 1" Bsp
- Max hose length 10m
- Weight 22 Kg bare
- Pack Dimensions 300x550x450



ICT 36220



ICT 36100
Spring driven heavy duty hose reel fixed arms ideal for 15m 1" hose for oils

- Optional swivel bracket 39505
- Max pressure 20 Bar
- Inlet M1" Bsp outlet F1" Bsp
- Hose 1" Bsp
- Max hose length 15m
- Weight 26 Kg bare
- Pack Dimensions 360x550x540



ICT 39505



ICT 35815
20m Spring driven Air reel

- Outer Diameter 10mm Ø

SWIVELS FOR OIL & GREASE



ART. 9969
 1" Male 20 Bar

HOSE STOPS



ART. 37004 3/4"



ART. 37005 1"



ART. 37001 1/4"
ART. 37002 "
ART. 37003 1/8"



ICT 40400
1/4" Regulator & Gauge

ICT40400-1
1/2" Regulator & Gauge



ICT 40360
1/4" Regulator & Gauge + Auto

ICT40360-1
1/2" Regulator & Gauge



ICT 40200
1/4" Air Filter

ICT40200-1
1/2" Air Filter



ICT 40300
1/4" Regulator,
Lubricator
& Filter Kit

ICT 40300-1
1/2" Regulator, Lubricator
& Filter Kit

ICT 40300-2
1" Regulator, Lubricator
& Filter Kit



ICT 22-2PM
1/4" Male with
1/4" Male Thread



ICT 22-2PH
1/4" Male Hose Tale



ICT 22-2SF
1/4" Female



ICT 22-2PF
1/4" Female Thread



ICT 430XX
Available in various
lengths & sizes



ICT 40630
Parafin spray gun



ICT 0473
1" Ball Valve



ICT 1342
1/2" Ball Valve



ICT 1733
3/8" Ball Valve



ICT 50129
40L Foam Sprayer with
7.5m hose & gun
• Weight 15 Kg
• Packing dimensions
400x430x1020



ICT 50155
40L Stainless Steel
Foam Sprayer
• Weight 16 Kg
• Packing dimensions
400x430x1020



PRESSURE TABLE



kPa = 0,01 bar
Mpa = 10,00 bar

1kPa = 0,145 P.S.I
1kp/cm2 = 14,223 P.S.I

kp/cma = 1,00 at
1 P.S.I = 6,895 kPa

kPa	Mpa	bar	kp/cm	P.S.I
5	0,005	0,05	0,05	0,73
10	0,01	0,1	0,10	1,45
25	0,025	0,25	0,25	3,63
50	0,05	0,5	0,51	7,25
75	0,075	0,75	0,76	10,88
100	0,1	1	1,02	14,5
200	0,2	2	2,04	29,0
300	0,3	3	3,06	43,5
400	0,4	4	4,08	58
500	0,5	5	5,10	72,5
600	0,6	6	6,12	87
700	0,7	7	7,14	102
800	0,8	8	8,16	116
900	0,9	9	9,18	131
1000	1	10	10,2	145
2000	2	20	20,4	290
3000	3	30	30,6	435
4000	4	40	40,8	580
5000	5	50	51,0	725
6000	6	60	61,2	870
7000	7	70	71,4	1015
8000	8	80	81,6	1160
9000	9	90	91,8	1305
10000	10	100	102	1450
11000	11	110	112	1595
12000	12	120	122	1740
13000	13	130	133	1885
14000	14	140	143	2030

kPa	Mpa	bar	kp/cm	P.S.I
15000	15	150	152	2175
16000	16	160	163	2320
17000	17	170	173	2465
18000	18	180	183	2610
19000	19	190	194	2755
20000	20	200	204	2900
21000	21	210	214	3045
22000	22	220	224	3190
23000	23	230	235	3335
24000	24	240	245	3480
25000	25	250	255	3625
26000	26	260	265	3770
27000	27	270	275	3915
28000	28	280	286	4060
29000	29	290	296	4205
30000	30	300	306	4350
31000	31	310	316	4495
32000	32	320	326	4640
33000	33	330	337	4785
34000	34	340	347	4930
35000	35	350	357	5075
36000	36	360	367	5220
37000	37	370	377	5365
38000	38	380	387	5510
39000	39	390	398	5655
40000	40	400	408	5800
41000	41	410	418	5945
42000	42	420	428	6090

kPa	Mpa	bar	kp/cm	P.S.I
43000	43	430	438	6235
44000	44	440	449	6380
45000	45	450	459	6525
46000	46	460	469	6670
47000	47	470	479	6815
48000	48	480	489	6950
49000	49	490	500	7105
50000	50	500	510	7250
51000	51	510	520	7395
52000	52	520	530	7540
53000	53	530	540	7685
54000	54	540	551	7830
55000	55	550	561	7975
56000	56	560	571	8120
57000	57	570	581	8265
58000	58	580	591	8410
59000	59	590	602	8555
60000	60	600	612	8700
61000	61	610	622	8845
62000	62	620	632	8990
63000	63	630	642	9135
64000	64	640	653	9280
65000	65	650	663	9425
66000	66	660	673	9570
67000	67	670	683	9715
68000	68	680	693	9860
69000	69	690	704	10005
70000	70	700	714	10150

NOTES



- FIELD SERVICE TRUCKS • REBUILDS • WORKSHOP INSTALLATIONS •
- UNDERGROUND LUBRICATION BAYS • DIESEL & OIL PIPELINE INSTALLATIONS •

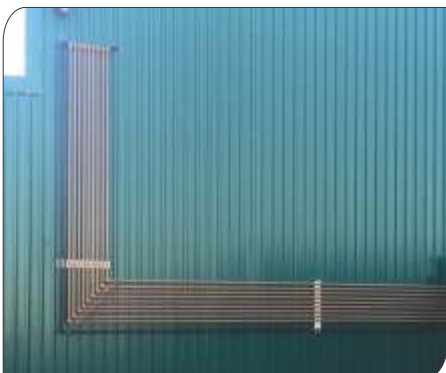



Distributor



HEAD OFFICE

40 Colin Wade Street, Delville
Ext 6, Germiston, 1401
Telephone: +27 (11) 824 2941/5
Facsimilie: +27 (11) 824 3155
Email: sales@ictus.co.za
P.O. Box 14404, Wadeville,
1422, South Africa



ICTUS

CATALOGUE

MANUFACTURERS & SUPPLIERS OF

LUBRICATION &
WORKSHOP EQUIPMENT

CAPE TOWN BRANCH

Unit 198 Prestige Business Park,
3 Platinum Close,
Marconi Beam
Mobile: +27 (82) 521 6388
Email: sales@ictus.co.za

DURBAN BRANCH

90 Columbine Place, Glen Anil
Mobile: +27 (82) 521 6388
Telephone: +27(31) 569 1696
Facsimilie: +27 (86) 514 1322
Email: kzn@ictus.co.za

ZAMBIA BRANCH

142 Eagle Street,
Nkana East, Kitwe,
Zambia
Telephone: 260 2 311163
Email: sales@ictus.co.za