



*Catalogue*  
**MINING**  
**EQUIPMENT**



**ICTUS**

Tel: +27 11 824 2941  
Email: [sales@ictus.co.za](mailto:sales@ictus.co.za)  
Website: [www.ictus.co.za](http://www.ictus.co.za)

# Table of Contents

- PRESSURE TABLE 1
- ABOUT US 2
- AIR OPERATED GROUT PUMPS 3
- AIR OPERATED GROUT PUMP COMBO UNITS 4-5
- HAND OPERATED MIXING COMBO SETS, MIXING UNITS 6
- GROUT ACCESSORIES 7
- CHEMICAL & GROUT INJECTION UNITS 8
- ELECTRIC COMBO UNIT, ELECTRIC GROUT PUMP 9
- SHOTCRETE WET & DRY MACHINES, MINI EXPLOSIVE CHARGING UNITS 10
- INTENSIFIERS, PROPCUTTER & DIAPHRAM PUMPS 11
- DRILL BITS, CABLE TENSIONERS & GROUT GAUGE 12

# Pressure Table

kPa = 0,01 bar  
Mpa = 10,00 bar

1kPa = 0,145 P.S.I  
1kp/cm2 = 14,223 P.S.I

kp/cma = 1,00 at  
1 P.S.I = 6,895 kPa

kPa	Mpa	bar	kp/cm	P.S.I
5	0,005	0,05	0,05	0,73
10	0,01	0,1	0,10	1,45
25	0,025	0,25	0,25	3,63
50	0,05	0,5	0,51	7,25
75	0,075	0,75	0,76	10,88
100	0,1	1	1,02	14,5
200	0,2	2	2,04	29,0
300	0,3	3	3,06	43,5
400	0,4	4	4,08	58
500	0,5	5	5,10	72,5
600	0,6	6	6,12	87
700	0,7	7	7,14	102
800	0,8	8	8,16	116
900	0,9	9	9,18	131
1000	1	10	10,2	145
2000	2	20	20,4	290
3000	3	30	30,6	435
4000	4	40	40,8	580
5000	5	50	51,0	725
6000	6	60	61,2	870
7000	7	70	71,4	1015
8000	8	80	81,6	1160
9000	9	90	91,8	1305
10000	10	100	102	1450
11000	11	110	112	1595
12000	12	120	122	1740
13000	13	130	133	1885
14000	14	140	143	2030

kPa	Mpa	bar	kp/cm	P.S.I
15000	15	150	152	2175
16000	16	160	163	2320
17000	17	170	173	2465
18000	18	180	183	2610
19000	19	190	194	2755
20000	20	200	204	2900
21000	21	210	214	3045
22000	22	220	224	3190
23000	23	230	235	3335
24000	24	240	245	3480
25000	25	250	255	3625
26000	26	260	265	3770
27000	27	270	275	3915
28000	28	280	286	4060
29000	29	290	296	4205
30000	30	300	306	4350
31000	31	310	316	4495
32000	32	320	326	4640
33000	33	330	337	4785
34000	34	340	347	4930
35000	35	350	357	5075
36000	36	360	367	5220
37000	37	370	377	5365
38000	38	380	387	5510
39000	39	390	398	5655
40000	40	400	408	5800
41000	41	410	418	5945
42000	42	420	428	6090

kPa	Mpa	bar	kp/cm	P.S.I
43000	43	430	438	6235
44000	44	440	449	6380
45000	45	450	459	6525
46000	46	460	469	6670
47000	47	470	479	6815
48000	48	480	489	6960
49000	49	490	500	7105
50000	50	500	510	7250
51000	51	510	520	7395
52000	52	520	530	7540
53000	53	530	540	7685
54000	54	540	551	7830
55000	55	550	561	7975
56000	56	560	571	8120
57000	57	570	581	8265
58000	58	580	591	8410
59000	59	590	602	8555
60000	60	600	612	8700
61000	61	610	622	8845
62000	62	620	632	8990
63000	63	630	642	9135
64000	64	640	653	9280
65000	65	650	663	9425
66000	66	660	673	9570
67000	67	670	683	9715
68000	68	680	693	9860
69000	69	690	704	10005
70000	70	700	714	10150



# About US

Ictus Equipment is a mining and lubrication company, founded in 1979. We manufacture pumps that are efficient, robust, reliable and cost effective.

We consist of three divisions; namely a **Mining and Construction division**, a **Lubrication and workshop division** and our **Underground contracting division**.

[The Mining/Construction division](#) offers locally manufactured cement and grout pumps and mobile hand and air grout and cement mixers as well as the newly developed Electric Maxi Mixer which is used for continuous batch mixing and pumping.

[The Lubrication division](#) offers a wide range of oil and grease pumps, hand and air operated, hose reels, meters, dispensing guns and accessories and transfer kits to name a few.

[Our Underground contracting division](#) specializes in pipelines installations, lube bay installations , grouting & whitewashing as well as many custom installations per the individual project specifications

Thanks to the quality of our products we have also secured contracts to design and fit mobile workshops for Government vehicles and are responsible for the servicing and maintaining of the equipment. With the diversification of our customer base we are always introducing new and innovative products helping us to grow and break into new markets.

Our main focus remains on our consumer and we strive to manufacture the best possible quality at the best possible prices in the shortest possible time. Through intensive testing and quality control we have labelled all of our products "Performance Proven", we carry this logo with pride as it is our personal quality guarantee.



**HEAD OFFICE:  
3 COLIN WADE STREET  
DELVILLE EXT 6, GERMISTON  
WWW.ICTUS.CO.ZA  
SALES@ICTUS.CO.ZA  
TEL: +27 11 824 2941**



## ICTUS M300 SERIES

- ROOF BOLTING
- WHITE WASHING
- GROUTING UP TO 10M
- ANCHORS
- RATIO 5:1 BUILT IN LUBRICATOR
- AIR SUPPLY MIN 2,5 BAR, 8 BAR MAX
- MAX WORKING PRESSURE 42 BAR
- FLOW RATE OPEN END 46L/MIN
- OUTLET 3/4" BSP
- AIR INLET 1/2 BSP



ICT 111/300

- TUBE Ø 60MM
- LENGTH 650MM
- WEIGHT 14KG
- PACKING DIMENSIONS 340X260X1090

## MKIII SERIES

MAINLY USED FOR PRESTRESSING OF WEEPING BAGS

- RATIO 10:1 BUILT IN LUBRICATOR
- AIR SUPPLY MIN 3,0 BAR, 8 BAR MAX
- MAX WORKING PRESSURE 96 BAR
- FLOW RATE OPEN END 32L/MIN
- OUTLET 1" BSP
- AIR INLET 1/2 BSP



ICT 123

- TUBE Ø 72MM
- LENGTH 375MM
- WEIGHT 16.5KG
- PACKING DIMENSIONS 460X460X720



ICT 120  
ICTUS M500 DIVORCED SERIES

- GROUTING OF CHEMICAL BASED GROUTS
- PUMP UP TO A 20M HEAD WITH GROUT
- DISCHARGE AWAY FROM MAIN BODY
- RATIO 10:1 BUILT IN LUBRICATOR
- AIR SUPPLY MIN 3.0 BAR MAX 8BAR
- MAX WORKING PRESSURE 110 BAR
- FLOW RATE OPEN END 28L/MIN
- OUTLET 1" BSP
- AIR INLET 1/2 BSP
- TUBE Ø 60MM
- LENGTH 650MM
- WEIGHT 21.2KG
- PACKING DIMENSIONS 460X460X1110



ICT 122

- TUBE Ø 72MM
- LENGTH 650MM
- WEIGHT 14KG
- PACKING DIMENSIONS 460X460X1100

## ICTUS M500 SERIES

- IDEAL FOR GROUTING ANCHORS UP TO 20M, WHILE WASHING & PACK SPRAYING
- RATIO 10:1 BUILT IN LUBRICATOR
- AIR SUPPLY MIN 3,0 BAR, 8 BAR MAX
- MAX WORKING PRESSURE 110 BAR
- FLOW RATE OPEN END 28L/MIN
- OUTLET 1" BSP
- AIR INLET 1/2 BSP



ICT 121  
STANDARD

- TUBE Ø 72MM
- LENGTH 650MM
- WEIGHT 16KG
- PACKING DIMENSION 460X460X1090



ICT 121STUB

- TUBE Ø 60MM
- LENGTH 375MM
- WEIGHT 13.8KG
- PACKING DIMENSION 340X260X1090



ICT 121-4AS-CM

M500 ANTI STATIC FOR COAL MINING



## ICTUS ICT 136 CM5001/500 GROUT PUMP & MIXER

- IDEAL FOR PACKSPRAYING, ANCHORS, VOID FILLING, CONSTRUCTION FOUNDATION PILING, VENTILATION WALLS, PIPE JACKING & FOUNDATION STABILIZATION
- M500 STD GROUT PUMP
- 75LITRE SIDE SHUTE DRUM
- CROSS PLATE MIXING PADDLE
- GEARBOX AIR MOTOR COMPLETE
- AIR MOTOR 7,5KW
- TORQUE AT 30R/M 80NM
- EFFECTIVE MIXING SPEED 30-160 RPM
- MIN AIR CONSUMPTION FOR PUMP 0,011M /SEC 23CFM
- MIXER 0,032 M SEC (45CFM)
- WEIGHT COMBINED 59KG
- PACKING DIMENSIONS - DRUM 470X470X680
- GEARBOX 310X320X460 | PUMP 460X460X1090

### OPTIONAL:

- SPRAY GUNS, DISCHARGE HOSES, FITTINGS, VALVES & OUTPUT PRESSURE GAUGES



## ICTUS 138 CM5002/500 GROUT PUMP & MIXER

- IDEAL FOR PACKSPRAYING, ANCHORS, VOID FILLING, CONSTRUCTION FOUNDATION PILING, VENTILATION WALLS, SOIL NAILING & PIPEJACKING
- M500 STD GROUT PUMP
- 90LITRE SIDE SHUTE DRUM
- CROSS PLATE MIXING PADDLE
- GEARBOX AIR MOTOR COMPLETE
- AIR MOTOR 7,5KW
- TORQUE AT 30R/M 80NM
- EFFECTIVE MIXING SPEED 30-160 RPM
- MIN AIR CONSUMPTION FOR PUMP 0,011M SEC (23CFM)
- MIXER 0,032 M SEC 45CFM
- WEIGHT COMBINED 70KG
- PACKING DIMENSIONS: DRUM 700X700X640
- GEARBOX 310X320X460 | PUMP 460X460X1090

### OPTIONAL:

- SPRAY GUNS, DISCHARGE HOSES, FITTINGS, VALVES & OUTPUT PRESSURE GAUGES



## ICTUS 138 PC CM5002MF/M500 GROUT PUMP & MIXER

- NEW 90 LITRE HEAVY DUTY ROBUST PLASTIC MIXING DRUM, WITH BUILT IN PUMP FLUSHER CHAMBER AND DRAIN VALVE.
- NO MORE DENTING OF DRUM
- GROUT EASY TO WASH OFF
- UNIT IS 15.75KG LESS IN WEIGHT
- CLEAN WATER AVAILABLE FOR FLUSHING AFTER PUMPING
- ALL IS DETACHABLE FOR EASY TRANSPORTATION AND CLEANING
- EFFECTIVE MIXING SPEED 30-160 RPM
- 7.5 KW AIRMOTOR GEARBOX
- M500 STD GROUT PUMP
- 10:1 RATIO
- FLOW RATE 28L/MIN
- MAX WORKING PRESSURE 110 BAR
- OUTLET 1" BSP
- INLET 1/2" BSP FEMALE WITHOUT ADAPTOR
- SUCTION TUBE 60MM



## ICTUS ICT 113 / CEM 300 HAND MIXER & GROUT PUMP

- IDEAL FOR PRESTRESSING OF NOW WEEP BAGS & CAN BE USED FOR UP TO 10M ANCHOR GROUTING
- M300 PUMP DETACHABLE S/STEEL RISER TUBE & LUBRICATOR
- 3/4" BSP OUTLET
- AIR INLET 1/2 BSP
- MIXING CAPACITY 80LITRES
- DOUBLE SCROLL FOR QUICK & EFFECTIVE MIXING
- HOSE 3/4" DISCHARGE 5M
- WEIGHT 34KG
- PACKING DIMENSIONS 610X640X1000



## CM 1001-60 HYDRAULIC GROUT PUMP

- 90L DRUM + MIXING PADDLE
- PUMPING HEAD 6M
- FLOW RATE 32L/PM
- COMPLETE WITH QUICK COUPLERS
- CAN BE MOUNTED ONTO UV PLATFORMS
- PUMP EASILY DETACHABLE FOR CLEANING

### OPTIONAL:

- HYDRAULIC DRIVEN MIXER
- 10M 1" DISCHARGE HOSE
- POWER BACK



## ICTUS ICT 159A AIR CINELE GRAVITY FED MIXER & AIR PUMP

- IDEAL FOR PUMPING UP TO 10M HOLES, ADVANTAGE NO GROUT WASTAGE COMPACT & USER FRIENDLY
- M300 GROUT PUMP S/STEEL RISER TUBE LUBRICATOR
- 3/4" BSP OUTLET
- AIR INLET 1/2 BSP
- MIXING CAPACITY 10LITRES
- HAND MIXER ON CROSS PLATE
- 5M 3/4" DISCHARGE HOSE
- WEIGHT 24KG
- PACKING DIMENSIONS 860X320X720



## ICTUS ICT 112/M300 WHITEWASH COMBO UNIT

- IDEAL FOR WHITE WASHING HAULAGE WAYS, WORKSHOPS ONE MAN OPERATION 100SQM IN 45MINS
- M300 - 2 PUMP INCL LUBRICATOR
- 3/4" BSP OUTLET
- AIR INLET 1/2" BSP
- 70 LITRE AIR AGITATED BUBBLE MIXER WITH T PIECE & VALVES
- 10M 1" DISCHARGE HOSE
- 11M 1/2" AIR HOSE COMPLETE WITH SPRAY GUN
- ICT402 MODEL
- WEIGHT 37KG
- PACKING DIMENSIONS 930X730X880

### OPTIONAL:

- EXTRA DISCHARGE HOSE

# HAND OPERATED MIXING COMBO SETS

## ICTUS ICT 184 MULTI GROUTER COMBO

- IDEAL FOR ANCHORS, HIGH SHEAR, PADDLE REMAINS FIXED.
- MIXING CAPACITY 21 LITRES
- HEAD 10M
- OUTLET 1" BSP
- HIGH SHEAR & MIXING BLADE
- BUILT IN PUMP FLUSHER
- DELIVERY PER STROKE 240ML
- WEIGHT 18.2KG
- PACKING DIMENSIONS 610X350X740

- **OPTIONAL**
- HOSE LENGTH
- AIR GROUT PUMP



## ICTUS ICT 147CM 0100 HAND UNIT

- USED FOR PRESTRESSING OF NON-WEEP SYSTEMS AS WELL AS GROUTING & VOID FILLING.
- 80 LITER DOUBLE SCROLL TYPE MIXER & FRAME
- OUTLET PUMP DISCHARGE 1" BSP
- HEAD 10M
- DISCHARGE HOSE 1" X 5M
- PUMP EASILY DETACHABLE FROM MIXER
- WEIGHT 37KG
- PACKING DIMENSIONS: 610X640X1000

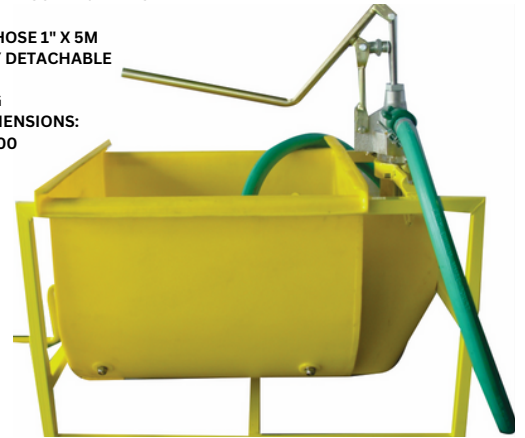

## MIXING UNITS ONLY

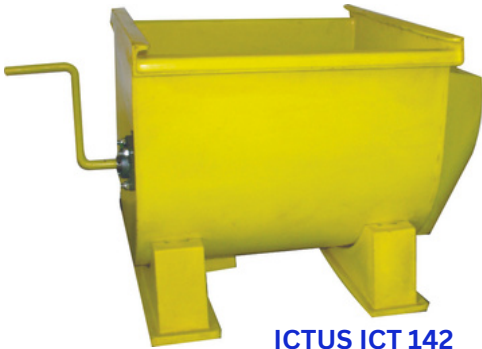

### ICTUS ICT 142 DOUBLE SCROLL MIXER

- 80 LITRE MIXING CAPACITY
- ROBUST (NOT RECYCLED MATERIAL)
- WEIGHT 18KG
- PACKING DIMENSIONS 970X560X820



### ICTUS ICT 141 AIR AGITATOR MIXER

- 70 LITRE MIXING CAPACITY
- COMPLETE WITH T PIECES
- WEIGHT 15KG
- PACKING DIMENSIONS 930X730X880

### ICTUS ICT 138 / 5002

- AIR DRIVEN MIXER
- 75 / 90 LITRE WITH SIDE SHUTE
- GEARBOX MOTOR & PADDLE
- WEIGHT 36KG,
- PACKING DIMENSIONS 700X700X640



### ICTUS ICT 138 PC MIXER & GEARBOX

- NEW 90 LITRE HEAVY DUTY ROBUST PLASTIC MIXING DRUM, WITH BUILT IN PUMP FLUSHER CHAMBER AND DRAIN VALVE.
- GEARBOX MOTOR & PADDLE
- 15.75 KG LIGHTER THAN STEEL DRUM
- PACKING DIMENSIONS 560X640X655



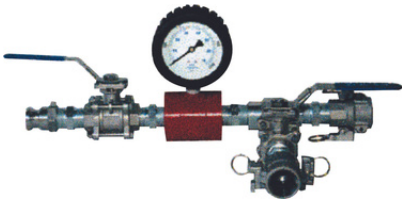

### ICT1678 - GAUGE

- 1" HIGH PRESSURE GAUGE USED TO CONTROL PRESSURE DURING GROUT INJECTION.
- VALVES ARE USED TO BYPASS GROUT BACK TO THE AGITATOR TANK.



### MINING HOSE VARIOUS SIZES & LENGTHS



### HOSE FITTINGS

- A) 1/2" HOSE TAIL SET
- B) 1" HOSE TAIL SET
- C) 1" HEAVY DUTY CLAMP
- D) 1/2" LIGHT DUTY CLAMP
- E) 1/2" STEEL HOSE TAIL SET
- F) 1/2" HEAVY DUTY STEEL CLAMP
- G) 1" STEEL HOSE TAIL SET
- H) 1/2" CLAW COUPLER



### ICT129 - M406 SPRAY GUN

- ROBUST
- 1" FM ENTRY
- AIR CONTROL VALVE
- IDEAL FOR APPLYING VISCOUS & NON VISCOUS MATERIAL AS WELL AS ABRASIVE
- WEIGHT 1.6KG
- PACKAGING 405X240X80



### ICT 133 - MOTOR

- ROTARY MOTOR
- AIR MOTOR POWER 7.5KW
- WEIGHT 5KG
- PACKING DIMENSION 260X180X180
- CAN BE USED FOR MANY OTHER APPLICATIONS.

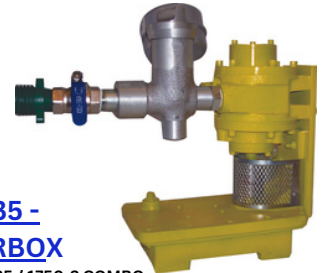

### ICT135 - GEARBOX

- ICTUS 135 / 1750-2 COMBO
- 7.5KW AIR MOTOR WITH REDUCTION SPEED GEARBOX
- TORQUE AT 30RPM = 80NM
- EFFECTIVE MIXING SPEEDS 30-160 RPM
- DRIVES ALL TYPES OF HIGH SHEAR PADDLES
- INLINE LUBRICATOR ICT68
- HEX BOTTOM FM ENTRY
- WEIGHT 18.2KG
- PACKING DIMENSIONS 310X320X460



### ICT 0473 - BALL VALVES



### ICT211 - CYLINDER COVER



### ORANGE MINING HOSE VARIOUS SIZES & LENGTHS

## ICTUS TSL SPRAY UNITS

### ICT 204 - TSL DIVORCED UNIT

TSL GRAVITY FED AIR DRIVEN UNIT SPRAYS MOST KINDS OF TSL PRODUCTS

- AIR INLET 1" BSP & OUTLET
- MIXING CAPACITY 70L
- MIXING SPEEDS 30-160R/PM
- M500 DIVORCED PUMP
- 10M DISCHARGE HOSE WITH SPRAY GUN AND CONNECTION HOSES
- OUTPUT PRESSURE: 80BAR
- DETACHABLE BUCKET
- 3 IN 1 AIR VALVE
- MINIMUM INPUT PRESSURE 4-8 BAR
- WEIGHT 85KG
- PACKAGING DIMENSIONS 1555 X 750 X 1300

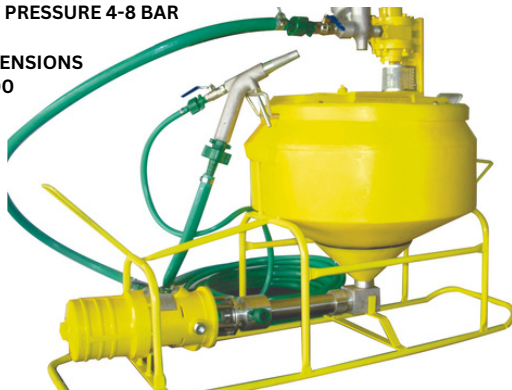

### ICTUS ICT 206 CONTINUOUS MIXER & DIVORCED PUMP

IDEAL FOR CONTINUOUS PUMPING & SPRAYING OF LARGE VOLUMES OF TSL & WHITEWASH & EASILY MANOEUVRED ON WHEELS.

- TOP MIXER CAPACITY 80L
- BOTTOM MIXER CAPACITY 85L
- OUTPUT PRESSURE UP TO 60 BAR
- AIR DRIVEN MIXING SPEEDS 30/160R/PM
- 3 IN 1 AIR VALVE ALL 1" BSP
- DETACHABLE M500DV PUMP
- OUTPUT PRESSURE 80BAR
- COMPLETE WITH 10M HOSE, SPRAY GUN & CONNECTION HOSES
- WEIGHT 144KG
- PACKING DIMENSIONS 1400X800X1650







## ICT 175 THIN LINE MEMBRANE UNITS

- ICTUS ICT 175 DOUBLE BARREL INJECTION PUMPS
- IDEAL FOR PUMPING TWO COMPONENTS AT VARIOUS RATIOS OR THE SAME INDIVIDUALLY TO THE SPRAY GUN OR SEPARATELY THROUGH THE OUTLET PORTS.
- 1:1 OR VARIABLE PUMPING CHAMBERS ALL STAINLESS STEEL
- 1" OUTLET PORTS OR 1X COMBINED OUTLET PORT
- AIR INLET 1" FEMALE
- WEIGHT 30KG
- PACKING DIMENSIONS 500X460X1000
- IDEAL FOR HIGH PRESSURE WATER
- SEALING & CHEMICAL APPLICATIONS

## M70B60 1:1 RATIO DOUBLE BARREL GROUT PUMP WITH IN-LINE MIXER.

- IDEAL FOR 2 COMPONENT GROUTS AND CHEMICALS
- STAINLESS STEEL IN-LINE MIXER
- DISCHARGE BLOCK
- STAINLESS STEEL FLUID SECTIONS
- 6,5 BAR AIR INLET PRESSURE = 130 BAR OUT
- 7 BAR AIR INLET PRESSURE = 150 BAR OUT
- 112 STROKES PER MINUTE
- 48 LITRES PER MINUTE



## ICTUS 8000-2 SERIES DOUBLE BARREL FOR 2 COMPONENT GROUTS

- RATIO AIR MOTOR 12:1 RATIO WET END DOUBLE BARREL 1:1
- DISPLACEMENT ROD Ø 35 OD PUMP DISPLACEMENT STROKE 105MM
- WET END, TUBE S/S Ø 48 X 43 ID WET END TUBE LENGTH 310MM
- AIR INLET 1" BSP CHAMBER OUTLET THREADS 1" BSP
- PUMP WEIGHT 40 KG PACKAGE SIZE 460 X 460 X 1090



### OPTIONAL:

- OUTLET HIGH PRESSURE VALVES FOR 2 CHAMBERS
- OUTLET GAUGES WITH GAUGE BLOCKS
- HIGH PRESSURE DOUBLE WIRE HOSES, AS REQUIRED
- DIFFERENT WET END LENGTHS AVAILABLE
- SUCTION HOSES, CAMLOCK FITTINGS AND DRUM PROBES

INPUT AIR	VOLUME PER STROKE, PER CHAMBER	STROKES PER MINUTE	LITRES PER MINUTE, PER CHAMBER	OUTPUT STALL PRESSURE
4 BAR	260ML	62	16,12±	48 BAR±
5 BAR	260ML	65	16,9±	60 BAR±
6 BAR	260ML	75	19,5±	72 BAR±
7 BAR	260ML	77	20,0±	84 BAR±

## ICTUS 8000-1 SERIES SINGLE BARREL

- RATIO AIR MOTOR 52.5:1
- DISPLACEMENT ROD: Ø 25
- PUMP DISPLACEMENT STROKE: 1 MIN = 106 STROKES
- 100ML / STROKE = 10.6L PER MIN
- 4 BAR IN = 210 BAR OUT
- WET END, TUBE S/S: Ø 48 X 43 ID
- WET END, TUBE LENGTH: 605MM
- AIR INLET: 1" BSP
- OUTLET THREADS: 1" BSP
- PUMP WEIGHT: 30 KG
- PACKAGE SIZE: 460 X 460 X 1090
- PUMP SUPPLIED COMPLETE WITH INLET LUBRICATOR FILTER & REGULATOR 1" AIR BALL VALVE.



## ICT 2014-2 ICTUS MAXI GROUTER

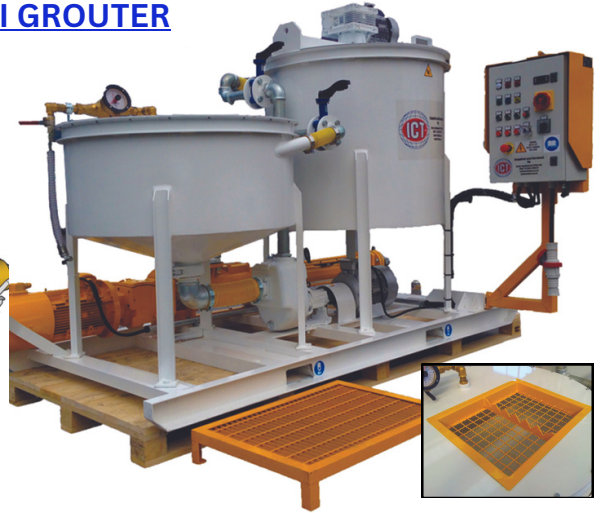
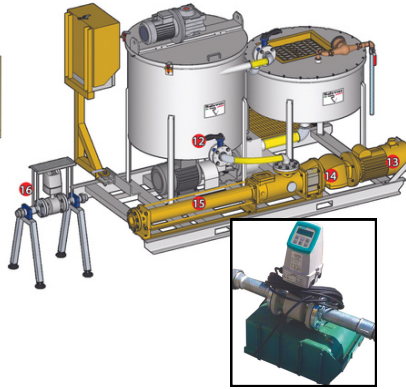
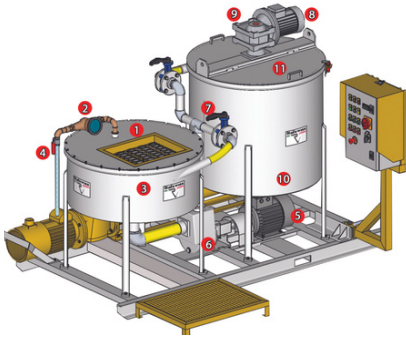

### TECHNICAL DATA:

HEIGHT 195CM  
 WIDTH 130CM  
 LENGTH 270CM  
 WEIGHT 1100KG

### ELECTRIC MOTORS

7,5KW HIGH SHEAR MIXER  
 3,0 KW AGITATOR  
 7,5 KW GROUTING PUMP  
 0,75 KW FAN MOTOR

### ELECTRONIC GROUT FLOW METER

#### FLOW RATE:

- 5M /H WITH POTENTIOMETER SET AT 5'
- 10M /H WITH POTENTIOMETER SET AT 10'

### COMPONENTS

1. CHARGING HOPPER WITH BAG BREAKER
2. MANUAL WATER METER
3. MIXING TANK
4. ELECTRIC MOTOR
5. IMPELLER
7. THROTTLES
8. ELECTRIC MOTOR
9. ADAPTER
10. AGITATOR TANKS
11. SAFETY COVERS
12. THROTTLE
13. ELECTRIC MOTOR
14. ADAPTER
15. PUMP UNIT
16. FLOW METER





TANK CAPACITY 350 LITRES HIGH SHEAR MIXER  
 700 LITRES AGITATOR  
 MAX PRESSURE 20 BAR  
 MAX FLOW RATE 3 10M /H - 166L/MIN

USED FOR FLUID MIXTURES SUCH AS MORTAR,  
 BENTONITE, ADDITIVES & CONCRETE  
 AGGREGATE  
 WITH A MAXIMUM OF 4MM GRAIN

# ELECTRIC GROUT PUMP

## ICT2010 - ELECTRIC GROUT PUMP

THE MARMOTTA 2010 MIXING PUMP ALLOWS TO MIX & PUMP CEMENT MORTARS WITH A GRAIN SIZE OF 3MM CONTINUOUSLY. ONE CAN ALSO USE IT TO SPRAY MORTAR (WITH USE OF A COMPRESSOR) DRY MORTAR OR CEMENT ARE PLACED INTO THE HOPPER & MOVE THROUGH THE WORM CONVEYER INTO THE MIXING CHAMBER IN WHICH A CONTINUOUS WATER FLOW MIXERS THE PUMPABLE MATERIAL, AFTER MIXING THE MATERIAL IS PUMPED THROUGH THE PUMP TO A MAXIMUM OF 100M AT AROUND 80 BAR, FLOW RATE WILL VARY DEPENDING ON BODY SIZE USED IDEAL FOR VOID FILLING & FOUNDATION PILING.

	MP2	MP3	MP7	MP8	MP13
STATOR					
ROTOR	240 lit/h	750 lit/h	960 lit/h	1380 lit/h	2160 lit/h
MOTOR 5.5 KW 400RPM	400 lit/h	1250 lit/h	1600 lit/h	2300 lit/h	3600 lit/h

### SPECIFICATIONS

- POWER SUPPLY 380V / 50HZ GEAR MOTOR 40KW 242RPM
- PUMPING DISTANCE 100M
- MAX GRAIN SIZE 3MM
- DISCHARGE HOSE R1-1" WITH MALE TO FEMALE SWIVEL
- TOTAL LENGTH 25M COMPLETE WITH 1" STAINLESS STEEL CAMLOCK COUPLERS
- TOTAL WEIGHT 180KG
- PACKING DIMENSIONS 1550X640X835

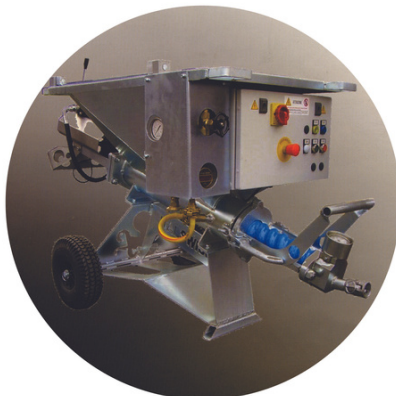



**ICT 45001 DRY MODEL**

- TECHNICAL DATA:
- LENGTH : 900MM
- WIDTH : 600MM
- HEIGHT : 900MM
- WEIGHT : 200KG
- OUTPUT UP TO 4 TONS/HOUR
- DISCHARGE:
- HORIZONTALLY 200M,
- VERTICALLY 100M
- AIR REQ. 4 - 6 BAR @ 240CFM
- ELECTRIC DRIVE 4 - 6 BAR @ 450CFM



**ICT 65002 DRY MODEL**

- TECHNICAL DATA:
- LENGTH : 1400MM
- WIDTH : 700MM
- HEIGHT 1200MM /
- WITH MIXER 1400MM
- WEIGHT +/- 500KG
- OUTPUT UP TO 4 CU.M/HOUR
- DISCHARGE HORIZONTALLY 180M
- AIR REQ. 4 - 6 BAR @ 750CFM
- ELECTRIC DRIVE
- 4 - 6 BAR @ 450CFM



**ICT 70004 WET MODEL**

- TECHNICAL DATA:
- LENGTH : 900MM
- WIDTH : 600MM
- HEIGHT : 900MM
- WEIGHT : 200KG
- OUTPUT UP TO 3 CU.M/HOUR
- PUMPING HEIGHT : 10M ,
- PUMPING DISTANCE 20M
- AGGREGATE SIZE 10MM, PAN MIXER 180L
- DISCHARGE:
- HORIZONTALLY UP TO 60M ,
- VERTICALLY UP TO 15M
- AIR REQ. 4 - 6 BAR @ 100CFM
- APPLICATIONS:
- TUNNEL SUPPORT, DAMS,
- VENTS SEALS, SHAFT &
- PIPE LININGS , BRIDGE REPAIRS

**OPTIONAL:**

- HOSES & NOZZLES

## MINI BULK EXPLOSIVE CHARGING UNITS

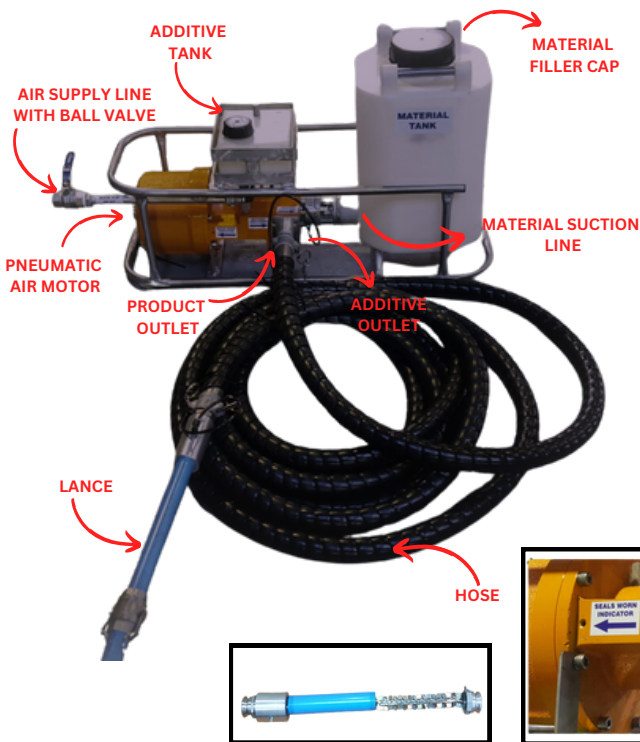

**ICT 600R - EMULSION PUMP**

- USED FOR PUMPING EMULSIONS IN CONFINED SPACES
- OR TWO COMPONENT MATERIALS.
- GASSING OR ADDITIVE RATIO MADE TO REQUIREMENT FOR MIXING.
- EASILY DETACHED FROM HOLDING TANK.
- MIXING ONLY TAKES PLACE AT THE FRONT NOZZLE THROUGH INLINE MIXER.
- THE EMULSION PUMP IS EQUIPPED WITH A PISTON PUMP CHOSEN FOR ITS
- SAFETY AND ABILITY TO HANDLE PRODUCT/MATERIAL WITH SHEAR SENSITIVE
- TENDENCIES AND HIGH VISCOSITIES.

DELIVERY LINE (M)	MASS FLOW RATE KG/MIN			
	3 BAR	4 BAR	5 BAR	6 BAR
3M		± 6,8 KG/MIN	± 9,2 KG/MIN	± 14 KG/MIN
5M	NEGLIGIBLE FLOW	± 8,2 KG/MIN	± 10.0 KG/MIN	± 11,7 KG/MIN
10M	NEGLIGIBLE FLOW	± 3,8 KG MIN	± 5,7 KG/MIN	± 8,1 KG/MIN
15M	NEGLIGIBLE FLOW	NEGLIGIBLE FLOW	NEGLIGIBLE FLOW	± 4,3 KG/MIN

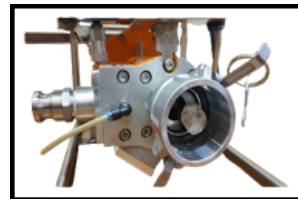

## PROPCUTTER



**ICT 183 PROP CUTTER**

- MAX CUTTING Ø 300MM
- AVERAGE CUTTING TIME Ø220 Ø19 SECS
- EXHAUST AIR KEEPS CHAIN LUBRICATED
- BUILT-IN SAFETY TRIGGER LATCH
- TUNGSTEN CHAIN
- AIR MOTOR SPEED 4 BAR 6500PPM
- AIR INLET 1"FM
- DECIBELS 97
- MIN AIR PRESSURE 3,5 BAR
- MAX AIR PRESSURE 8 BAR
- LUBRICATOR CAPACITY 25ML
- WEIGHT 28,5KG INCL OIL
- PACKING DIMENSION 850X350X490



## ICT 171-15 AIR INTENSIFIER

- 15MPA AIR INTENSIFIER
- ROBUST FOR MINING CONDITIONS
- FLOW RATE 8,3 LT P/MIN
- INPUT PRESSURE 4BAR = 15MPA
- INPUT PRESSURE 3,5BAR = 14MPA
- HOSES 5&3M & AUTO RELEASE ON GUN
- IDEAL FOR TOP HATS, ROCKPROPS & PRESTRESS PLATES
- PACKING DIMENSION 680X480X260 • WEIGHT 15KG



## ICT 171-28 AIR INTENSIFIER

- 28MPA AIR INTENSIFIER
- ROBUST FOR MINING CONDITIONS
- FLOW RATE 8,3 LT P/MIN
- INPUT PRESSURE 4BAR = 28MPA
- INPUT PRESSURE 3,5BAR = 24MPA
- HOSES 5&3M & AUTO RELEASE ON GUN
- IDEAL FOR SWELLEX BOLTS & OTHER
- PACKING DIMENSION 680X480X260 • WEIGHT 16KG



## ICT 171-40 AIR INTENSIFIER

- 40MPA AIR INTENSIFIER
- ROBUST FOR MINING CONDITIONS
- FLOW RATE 8,3 LT P/MIN
- INPUT PRESSURE 4BAR = 40MPA
- INPUT PRESSURE 3,5BAR = 36MPA
- DOUBLE WIRE HOSES 5&3M & AUTO RELEASE ON GUN
- IDEAL FOR STATIONERY PROPS
- PACKING DIMENSION 680X480X260 • WEIGHT 17KG



## HAND INLINE INTENSIFIER

- 15MPA HAND INTENSIFIER
- DIRECT WATER FEED OR TANK OPTION
- HOSE 4M WITH STEKO FITTING & COUPLER
- RELEASE VALVE ON OUTLET
- TANK CAPACITY 4 LITRES
- IDEAL FOR TOP HATS
- PACKING DIMENSION 360X155X300
- WEIGHT 12KG



## ICT 127/0875

## HAND INTENSIFIER

- 15MPA HAND INTENSIFIER
- DIRECT WATER FEED OR TANK OPTION
- HOSE 4M WITH STEKO FITTING & COUPLER
- RELEASE VALVE ON OUTLET
- TANK CAPACITY 4 LITRES
- IDEAL FOR TOP HATS
- PACKING DIMENSION 360X155X300
- WEIGHT 12KG



- A) ICT 1086** 3M STEKO-1/2" MALE
- B) ICT 1093** 5M STEKO-3/8" MALE
- C) ICT 173** HOSE ASSEMBLY 5+3M GUN, RELEASE VALVE, HOSE SPRING & COUPLER

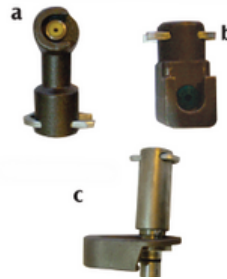

- A) ICT 156/0720** STEKO LIGHT DUTY SLIDE COUPLER + STEKO CLIP
- B) ICT 160** STEKO HEAVY DUTY SLIDE COUPLER + STEKO CLIP
- C) ICT 161** ROCKPROP CONNECTOR



## ICT 1087 / 1092

- HIGH PRESSURE TRIGGER GUN
- COMPLETE WITH SPRING RELEASE
- PRESSURE VALVE

## DOUBLE DIAPHRAM PUMPS



### ICT 40025

- MAX HEAD 84M
- MAX FLOW RATE 57L/MIN
- MAX PARTICLE Ø 2.5MM
- SUCTION & DISCHARGE SIZE 1/2"
- AIR INLET PORT 1/4" BSP
- MAX AIR INPUT 8.4BAR
- WEIGHT 5KG
- PACK DIMENSIONS 290X200X350

### ICT 40050

- MAX HEAD 84M
- MAX FLOW RATE 157L/MIN
- MAX PARTICLE Ø 4MM
- SUCTION & DISCHARGE SIZE 1"
- AIR INLET PORT 1/2" BSP
- MAX AIR INPUT 8.4BAR
- WEIGHT 10KG
- PACK DIMENSIONS 340X250X490



## DRILL BITS



**OUR 7 BUTTON CARBIDE DRILL BITS FROM 32MM UP, HIGH-GRADE MATERIAL FOR THE BODY WITH A HIGH WEAR RESISTANCE FACTOR.**

## CABLE TENSIONERS



**THE LIGHTEST AND MOST ERGONOMICAL FRONT GRIPPING JACK ON THE MARKET.**

**SUITABLE FOR TENSIONING 15MM (25T) AND 18MM (38T) CABLE ANCHORS.**

**ERGONOMICAL PLASTIC ENCASED HANDLES  
WEIGHT ONLY 15KG (16.3KG INCLUDING STANDARD PIPE AND SAFETY SLING).**

## GROUT GAUGE



### SPECIFICATIONS

- DIMENSIONS: 75MM(W) X 120MM(H) X 35MM(D)
- NR. OF SENSOR CHANNELS: 3
- DOWNLOAD & CHARGE INTERFACE: MINI-USB BATTERY
- TYPE: LITHIUM POLYMER
- BATTERY VOLTAGE AND CAPACITY: 3.7V 1100MAH
- CHARGING TIME: ±4 HOURS
- MAXIMUM CHARGE CURRENT: 300MA
- OPERATING TEMPERATURE RANGE: -10OC TO 55OC
- ENVIRONMENTAL RATING: IP54
- APPLICATION OPERATING SYSTEM: WINDOWS 7 & 10
- ENCLOSURE MATERIAL: FLAME-RESISTANT ABS UL94V-0

# Ictus EQUIPMENT

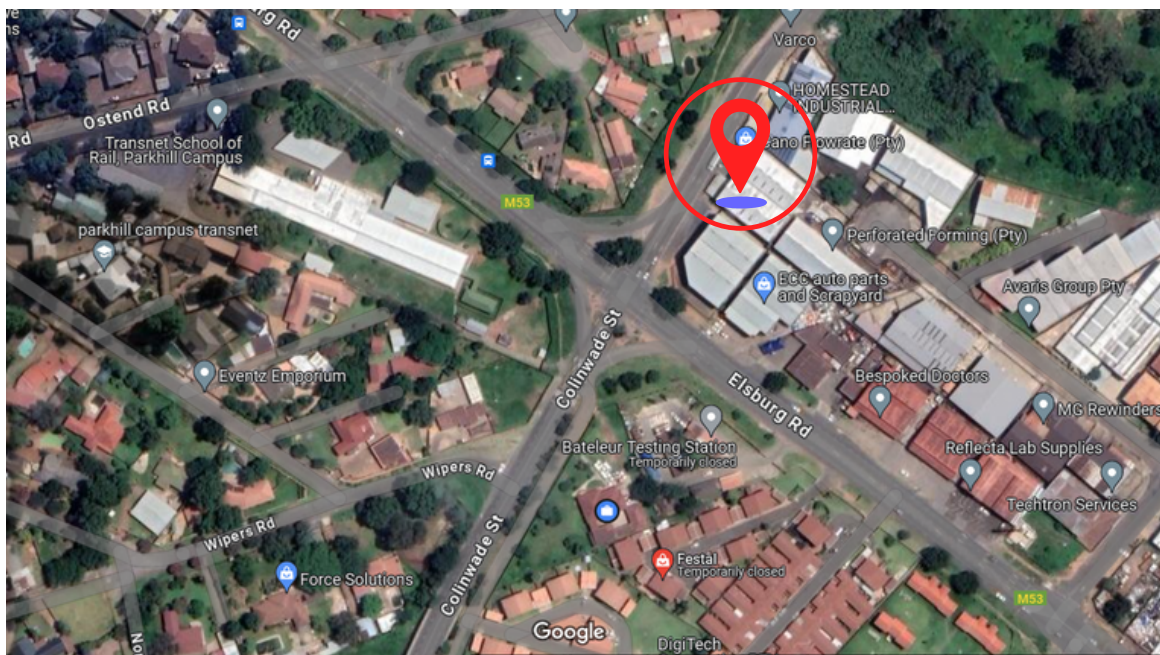

## TALK TO US

+27 11 824 2941  
SALES@ICTUS.CO.ZA  
WWW.ICTUS.CO.ZA

## FIND US

3 Colin Wade street  
Delville Ext 6  
Germiston, South Africa

