



FHT257-777 - 'TUNNEL TROUBLES'



FIREHOUSE TALES

©2005 Warner Bros. This Material is the PROPERTY OF WARNER BROS. TELEVISION ANIMATION. It is unpublished and must not be taken from the studio, duplicated or used in any manner, except for production purposes, and may not be sold or transferred.

Page 1

Sc.

Panel

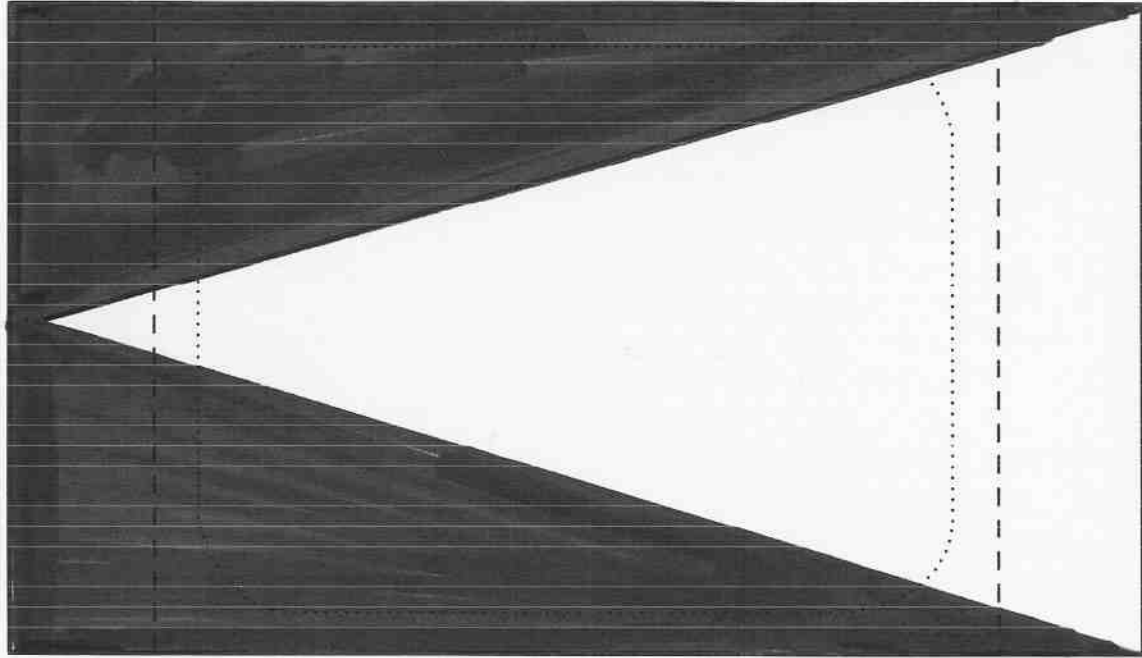

Dialogue Action

FADE IN.

Sc. 1

Panel

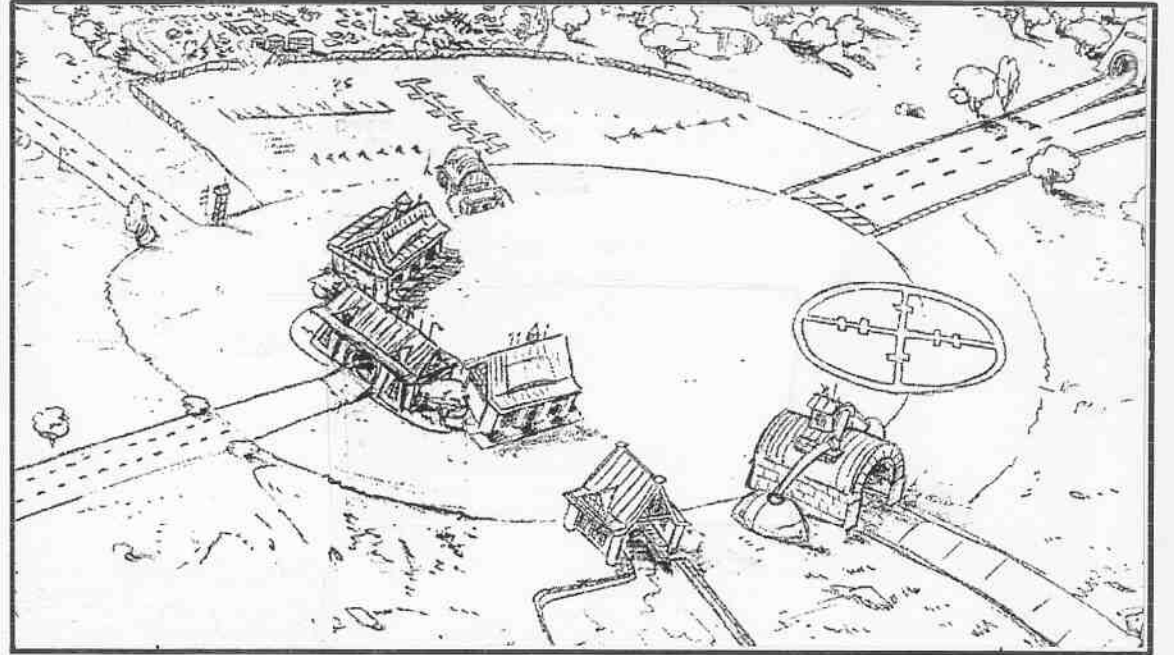

Dialogue Action

EXT. FIREHOUSE (DOWNSHOT) - NIGHT
TRUCK IN (A) + (B) (X-DISS DURING TRUCK IN)

X-DISS TO.



SFX: (CRICKETS CHIRPING, OWLS HOOTING etc)

WISER: (VO) "TUNNEL TROUBLE."

257-777



FIREHOUSE TALES

©2005 Warner Bros. This Material is the PROPERTY OF WARNER BROS. TELEVISION ANIMATION. It is unpublished and must not be taken from the studio, duplicated or used in any manner, except for production purposes, and may not be sold or transferred.

Sc. 2

Panel

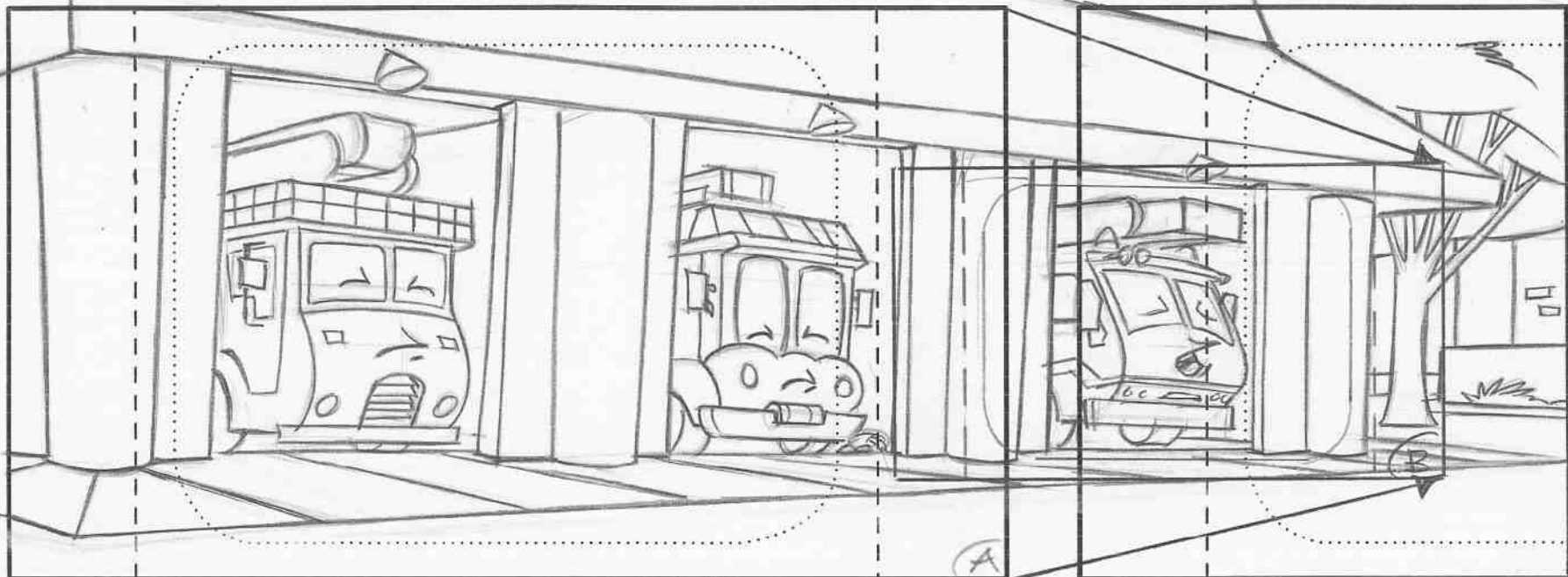

X-DISS FROM

Action EXT. FIREHOUSE - (NIGHT).
ANGLE ON THE SLEEPING TRUCKS.
PAN & TRUCK IN (A) → (B)

Dialogue WISER: (CONTD).

" ..AND ALL WAS PEACEFUL & QUIET "

Action

CUT

257-777



FIREHOUSE TALES

©2005 Warner Bros. This Material is the PROPERTY OF WARNER BROS. TELEVISION ANIMATION. It is unpublished and must not be taken from the studio, duplicated or used in any manner, except for production purposes, and may not be sold or transferred.

Sc. 3

Panel

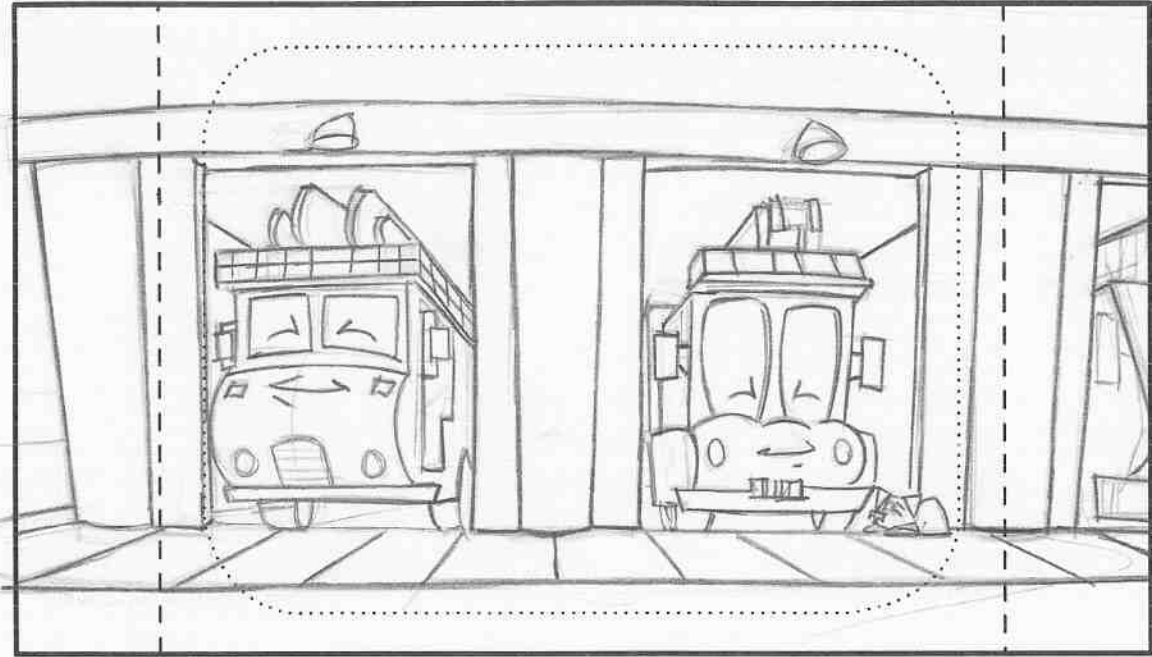

CUT **Action** ANGLE ON PETROL & RED SLEEPING PEACEFULLY. SQUIRT IS ALSO ASLEEP BY RED.

Dialogue ④ WISER: (VO)
WELL ALMOST QUIET.

Sc. CONTD

Panel ③

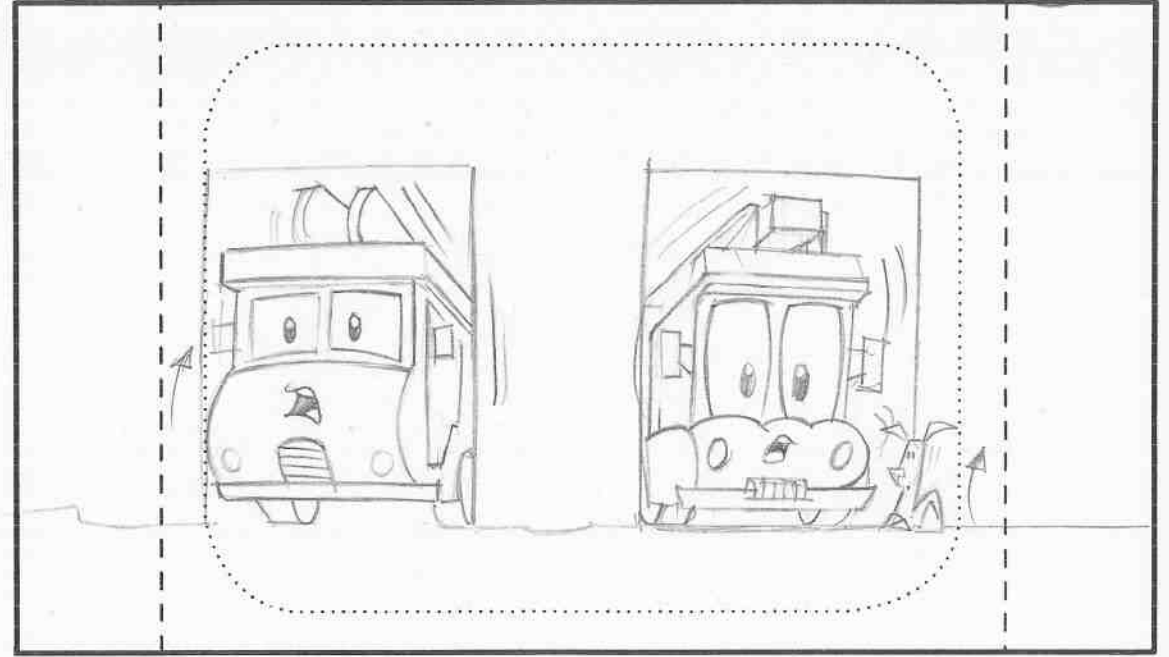

Action RED, PETROL & SQUIRT ARE SUDDENLY STARTLED AWAKE BY AN O.S. RUMBLING.

SFX: < RUMBLING! >
③ RED & PETROL:
HUH ?!

257-777



FIREHOUSE TALES

©2005 Warner Bros. This Material is the PROPERTY OF WARNER BROS. TELEVISION ANIMATION. It is unpublished and must not be taken from the studio, duplicated or used in any manner, except for production purposes, and may not be sold or transferred.

Sc. 3 CONTD

Panel (C)

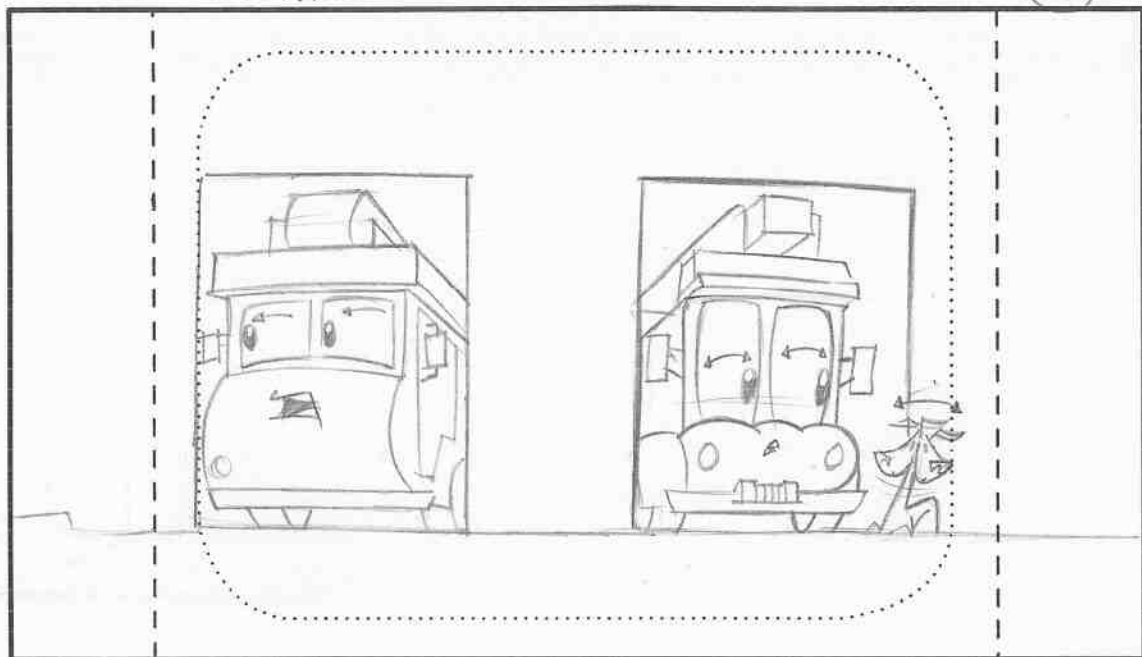

Dialogue Action PETROL, RED & SQUIRT LOOK AROUND

(CUT)

(5) PETROL:
BUST ME BLINKERS!

Sc. 4

Panel (A)

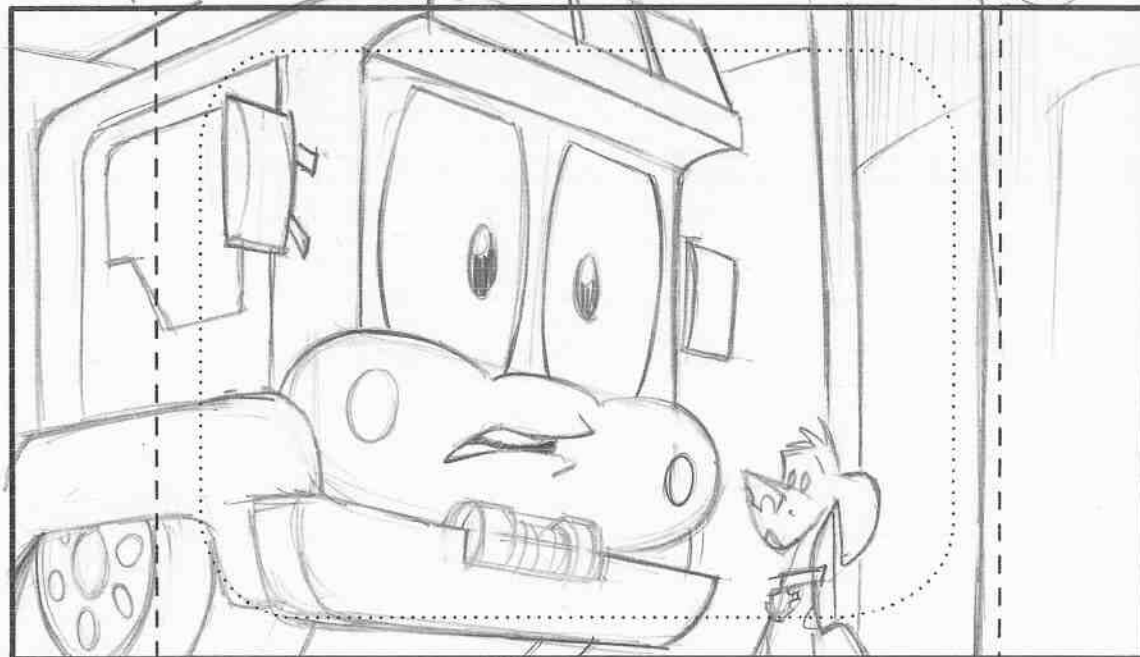

Dialogue Action CLOSE ON RED & SQUIRT

(6) RED:
NOT AGAIN!

257-777



FIREHOUSE TALES

©2005 Warner Bros. This Material is the PROPERTY OF WARNER BROS. TELEVISION ANIMATION. It is unpublished and must not be taken from the studio, duplicated or used in any manner, except for production purposes, and may not be sold or transferred.

Sc. 4 CONTD.

Panel B

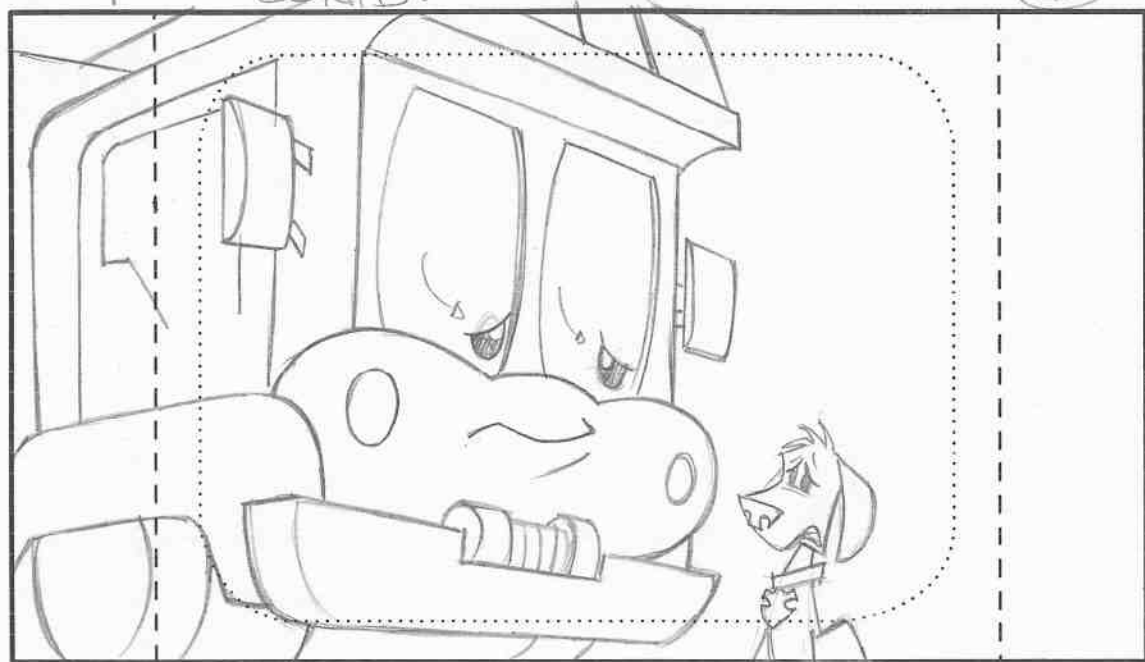

Action SQUIRT STARTS TO WHINE. RED LOOKS DOWN AT HIM.

Dialogue SQUIRT:
<WHINE, WHINE!>

CUT

Sc. 5

Panel A

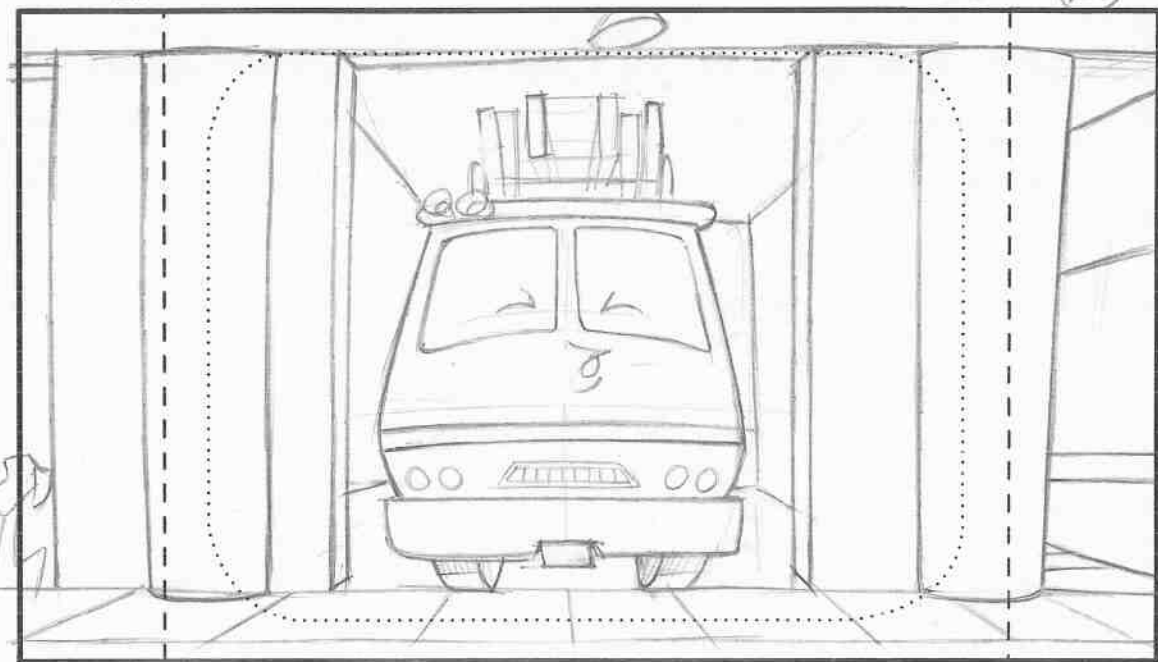

Action CLOSE ON CRABBY, SNORING AWAY.

Dialogue CRABBY:
<SNORING!>



FIREHOUSE TALES

©2005 Warner Bros. This Material is the PROPERTY OF WARNER BROS. TELEVISION ANIMATION. It is unpublished and must not be taken from the studio, duplicated or used in any manner, except for production purposes, and may not be sold or transferred.

Sc. 5 CONTD.

Panel (B)

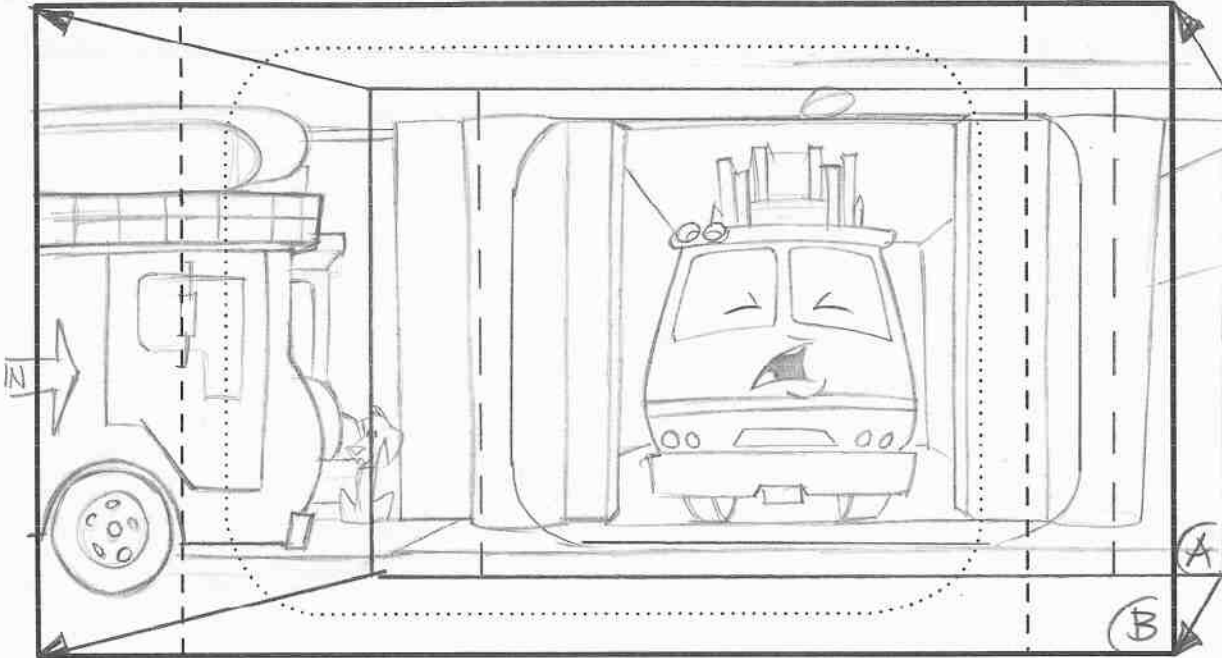

Dialogue Action TRUCK OUT (A) → (B) PETROL ROLLS IN.

Dialogue Action

Sc. CONTD.

Panel (C)

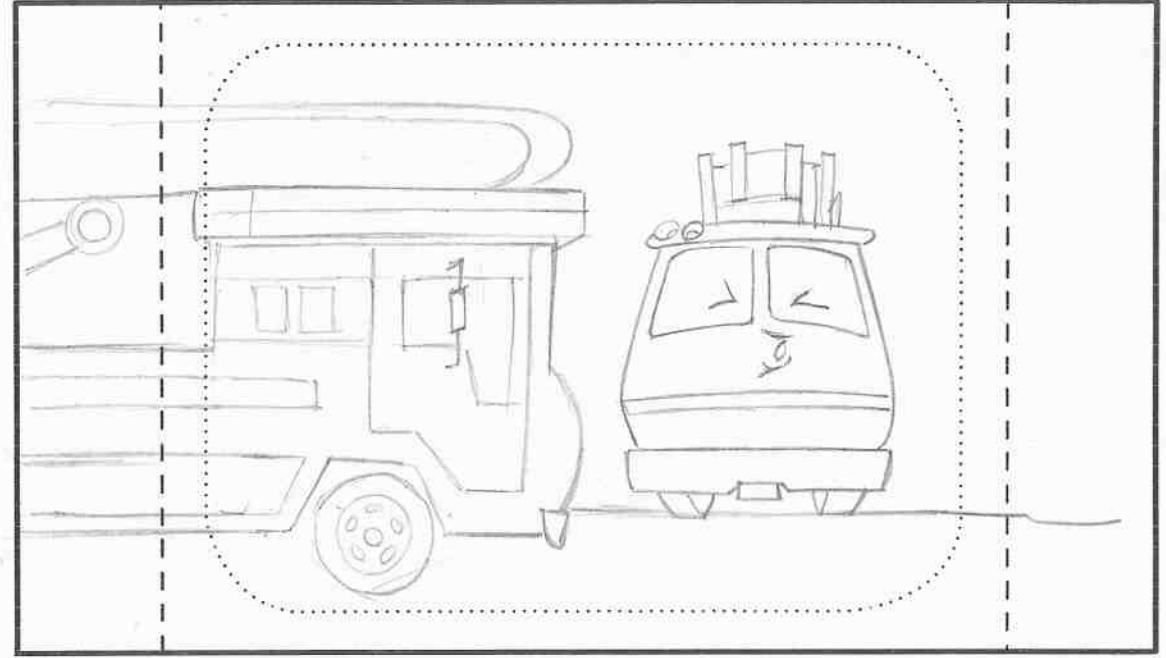

Dialogue Action (7) PETROL:
CRABBY?! CRABBY?!

Dialogue Action



FIREHOUSE TALES

©2005 Warner Bros. This Material is the PROPERTY OF WARNER BROS. TELEVISION ANIMATION. It is unpublished and must not be taken from the studio, duplicated or used in any manner, except for production purposes, and may not be sold or transferred.

Sc. 5 CONTD.

Panel (D)

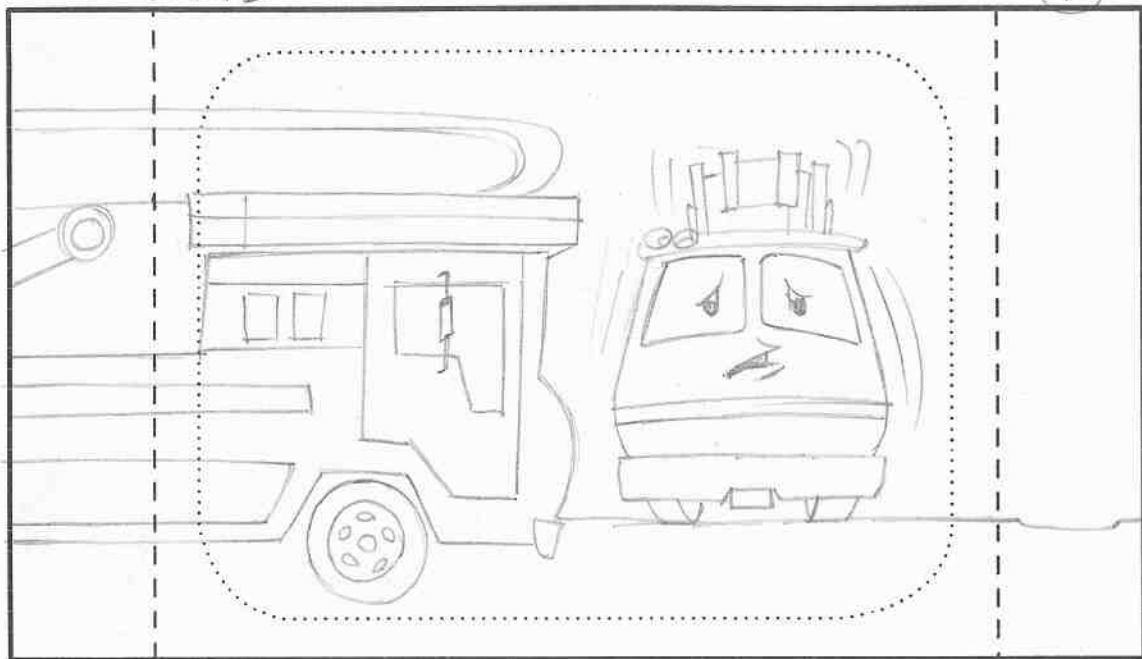

CRABBY "SNORTS" AWAKE.

Dialogue Action

CUT

(8) CRABBY:

HUH? WHA'?

Sc. 6

Panel

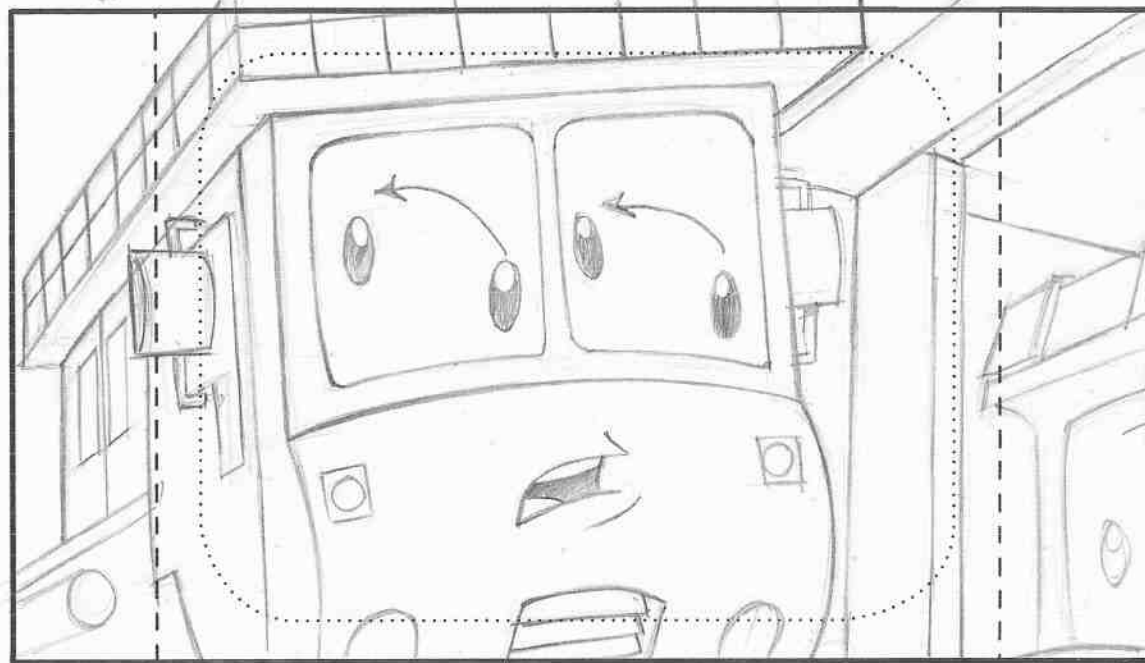

CLOSE ON PETROL. HIS EYE'S SHIFT

Dialogue Action

CUT

(9) PETROL:

DO YOU HEAR THAT NOISE?

257-777



FIREHOUSE TALES

©2005 Warner Bros. This Material is the PROPERTY OF WARNER BROS. TELEVISION ANIMATION. It is unpublished and must not be taken from the studio, duplicated or used in any manner, except for production purposes, and may not be sold or transferred.

Sc. 7

Panel

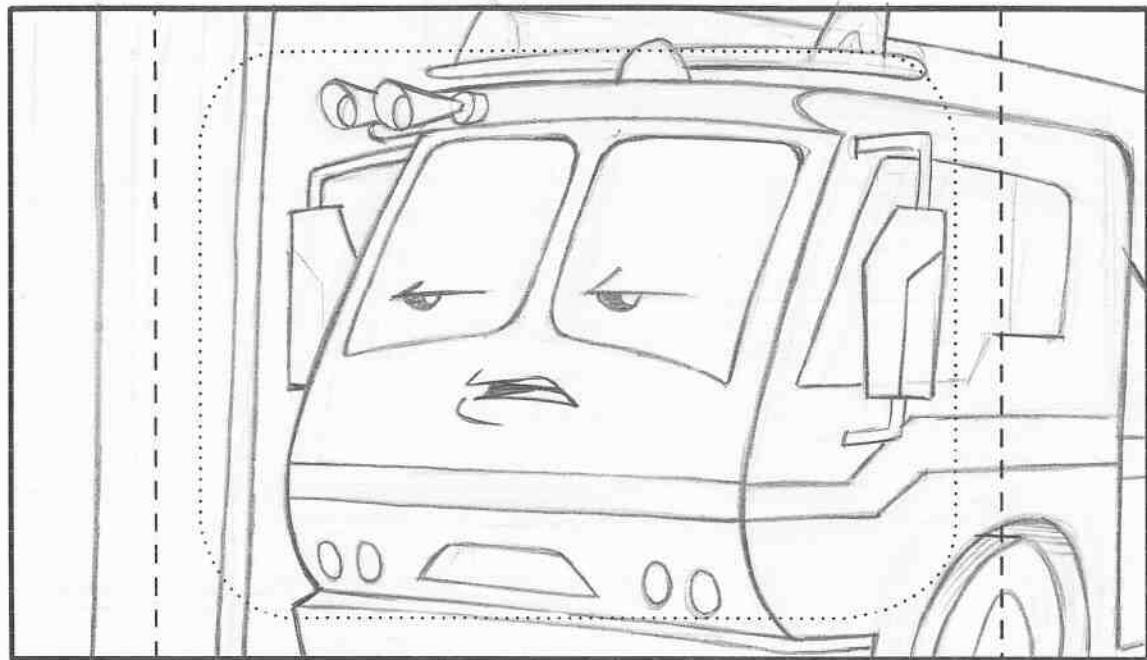

CUT

Dialogue Action

CLOSE ON CRABBY 'SHOOTING' PETROL A LOOK.

⑩ CRABBY:

I DO NOW!

Sc. 8

Panel

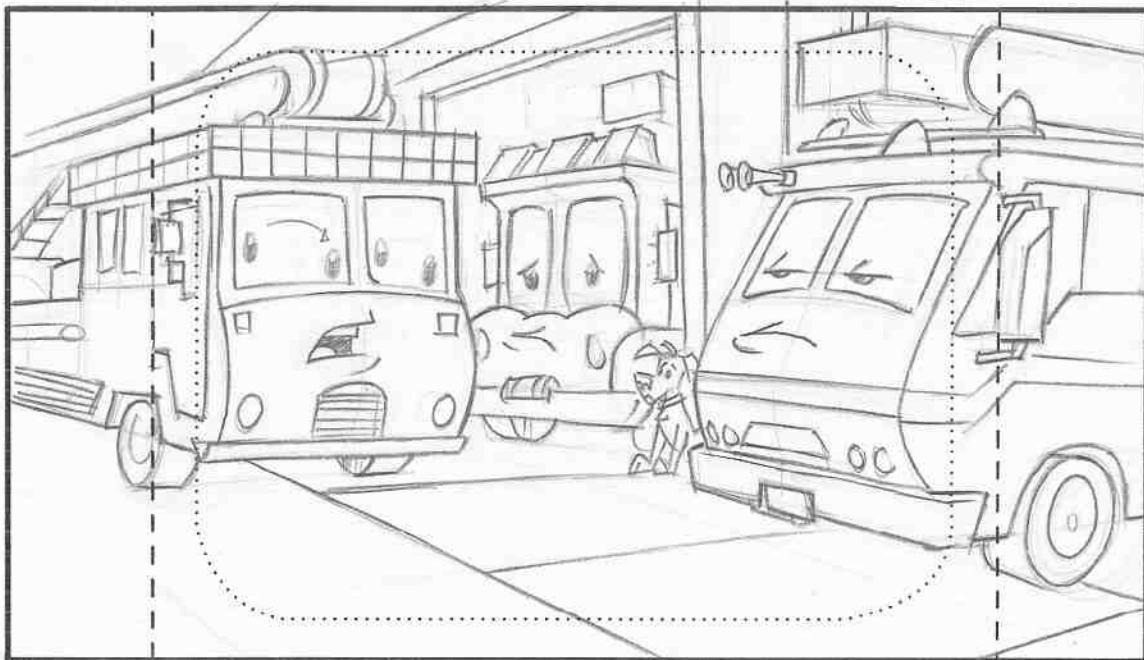

CUT

Dialogue Action

WIDE ON OUR TRIO. PETROL LOOKS OVER AT CRABBY.

⑪ PETROL:

EVERY NIGHT IT KEEPS ME AWAKE ..

CUT

257-777



FIREHOUSE TALES

©2005 Warner Bros. This Material is the PROPERTY OF WARNER BROS. TELEVISION ANIMATION. It is unpublished and must not be taken from the studio, duplicated or used in any manner, except for production purposes, and may not be sold or transferred.

Sc. 9

Panel

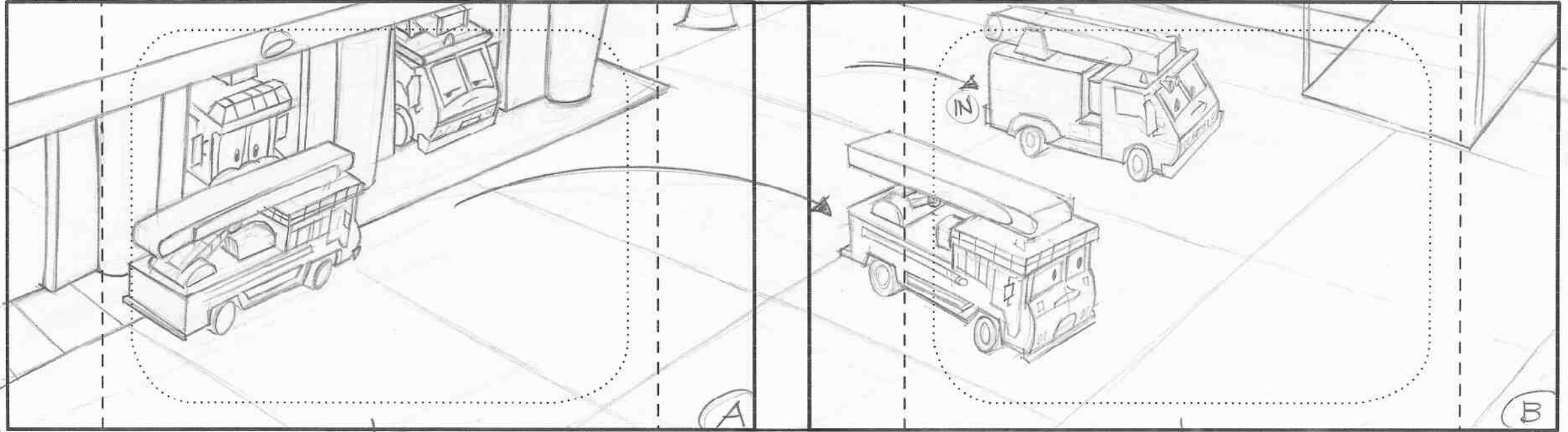

CUT

START

PAN

STOP

Dialogue Action WIDE ON COURTYARD (NIGHT) PETROL DRIVES FWD.

Dialogue Action PAN W/ANIM (A → B) AND STOPS. CRABBY FOLLOWS IN.

257-777



FIREHOUSE TALES

©2005 Warner Bros. This Material is the PROPERTY OF WARNER BROS. TELEVISION ANIMATION. It is unpublished and must not be taken from the studio, duplicated or used in any manner, except for production purposes, and may not be sold or transferred.

Sc. 9 COND.

Panel (B)

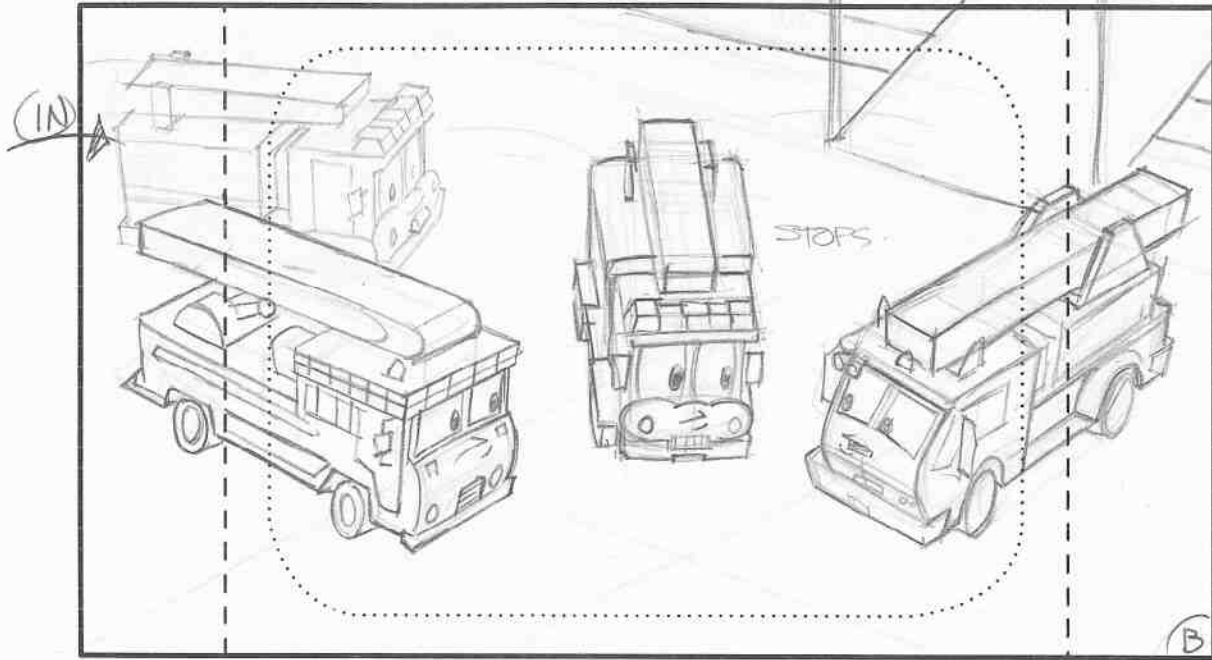

Dialogue Action ...AND STOPS NEAR PETROL. RED DRIVES IN STOPPING BETWEEN THEM.

(12) CRABBY:

IT'S OUT HERE TOO!

CUT

Sc. 10

Panel (A)

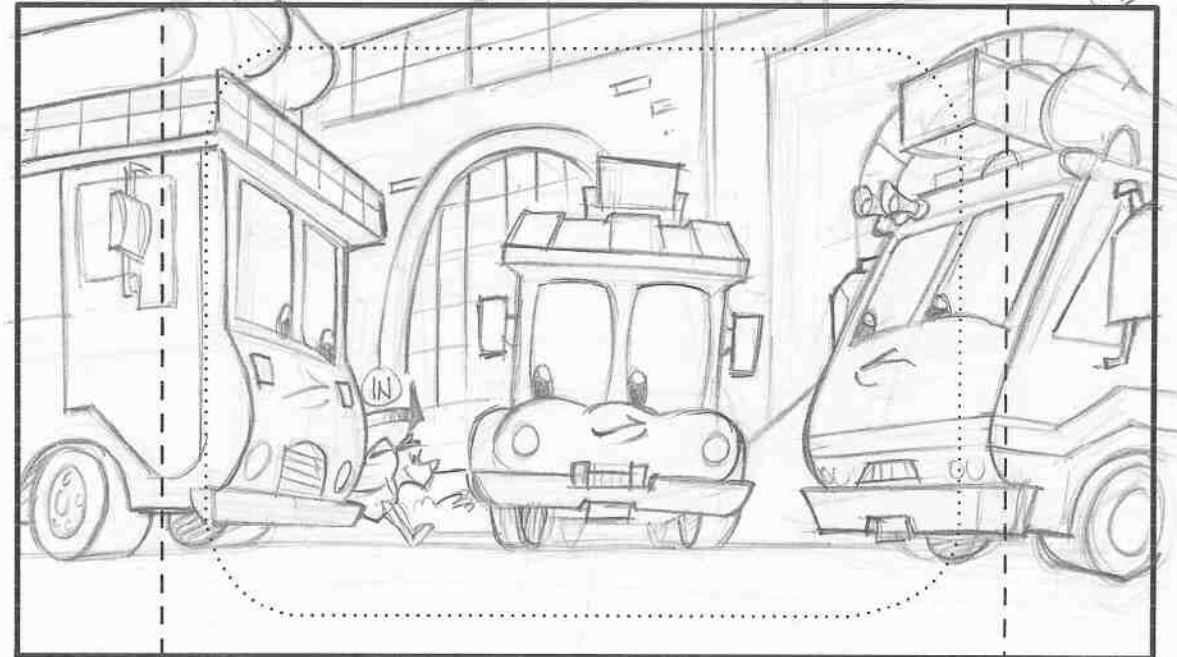

Dialogue Action ANGLE ON TRIO - SQUIRT RUNS IN

257-777



FIREHOUSE TALES

©2005 Warner Bros. This Material is the PROPERTY OF WARNER BROS. TELEVISION ANIMATION. It is unpublished and must not be taken from the studio, duplicated or used in any manner, except for production purposes, and may not be sold or transferred.

Sc. 10 CONTD

Panel B

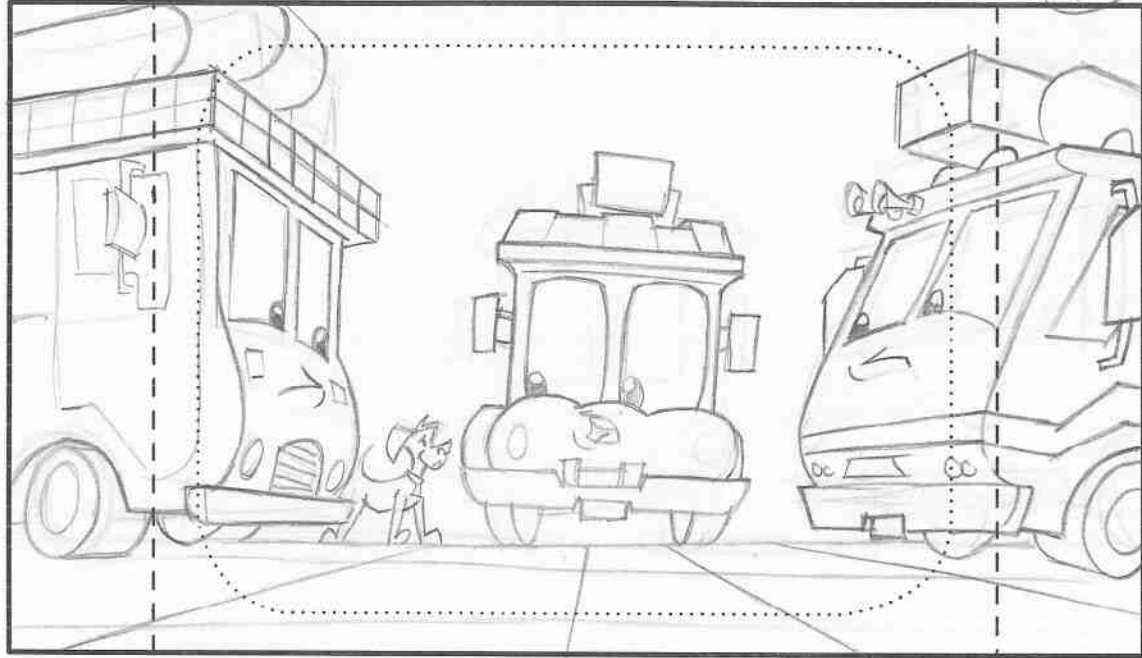

Dialogue Action

SQUIRT STOPS BESIDE RED.

(13) RED:

SQUIRT, CAN YOU TELL WHERE IT'S COMING FROM?

CUT

Sc. 11

Panel A

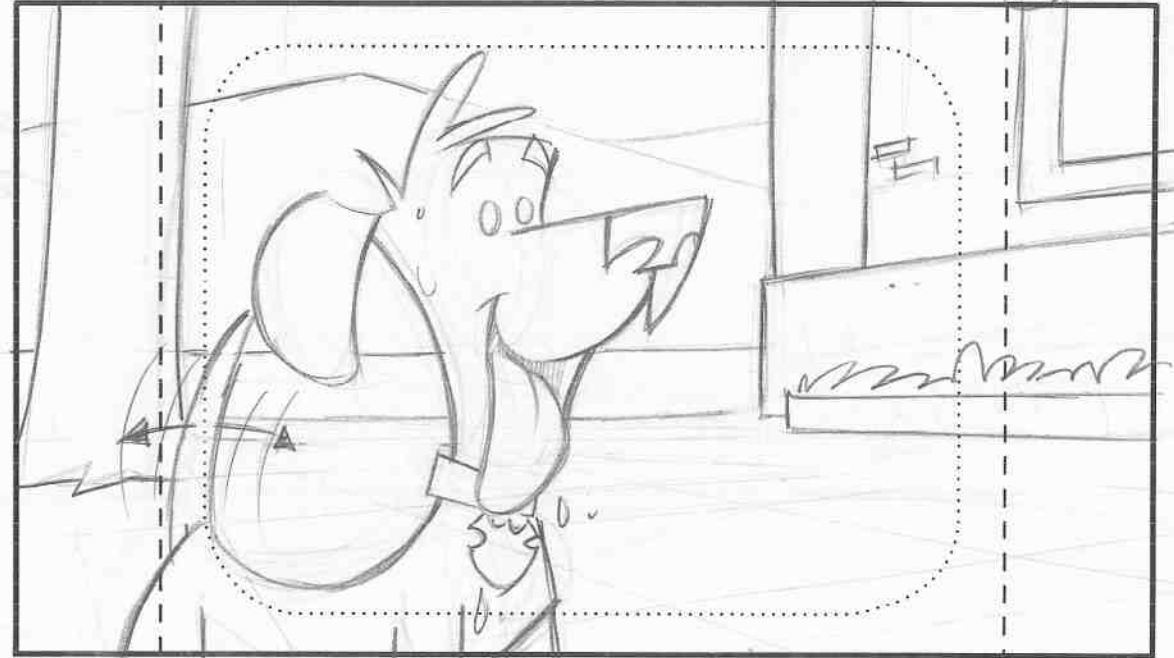

Dialogue Action

ANGLE ON SQUIRT.

EFX: (S/T DRUOL)



FIREHOUSE TALES

©2005 Warner Bros. This Material is the PROPERTY OF WARNER BROS. TELEVISION ANIMATION. It is unpublished and must not be taken from the studio, duplicated or used in any manner, except for production purposes, and may not be sold or transferred.

Sc. 11 CONTD

Panel (B)

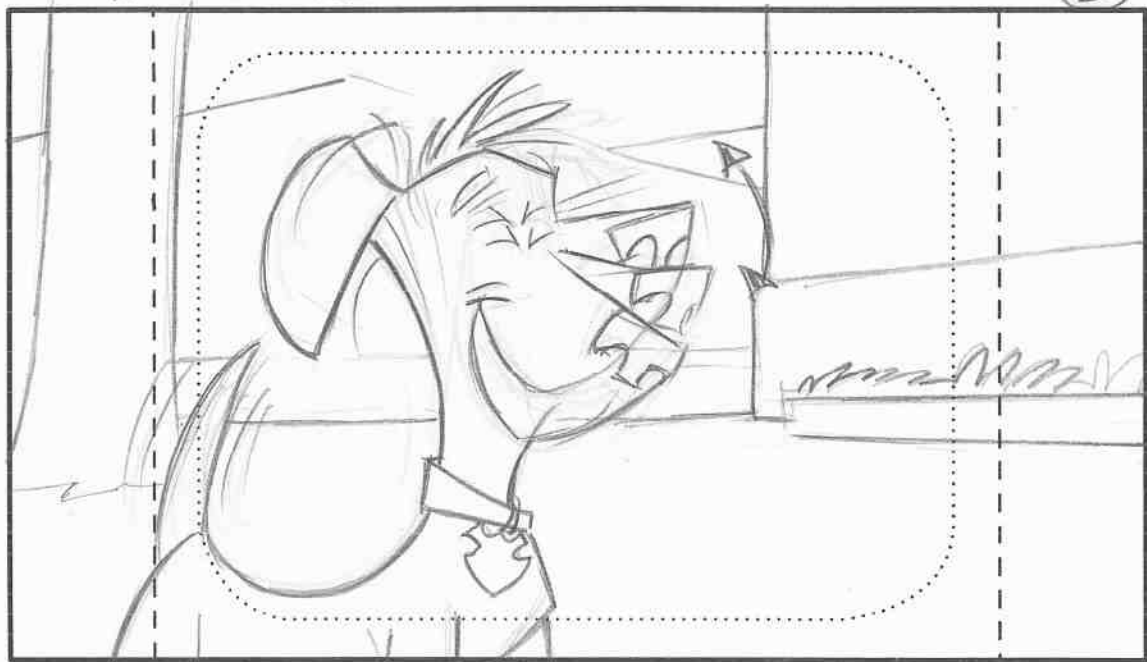

Dialogue Action

SQUIRT NODS HIS HEAD.

EFFX: (D/B BLUR)

Sc. CONTD

Panel (C)

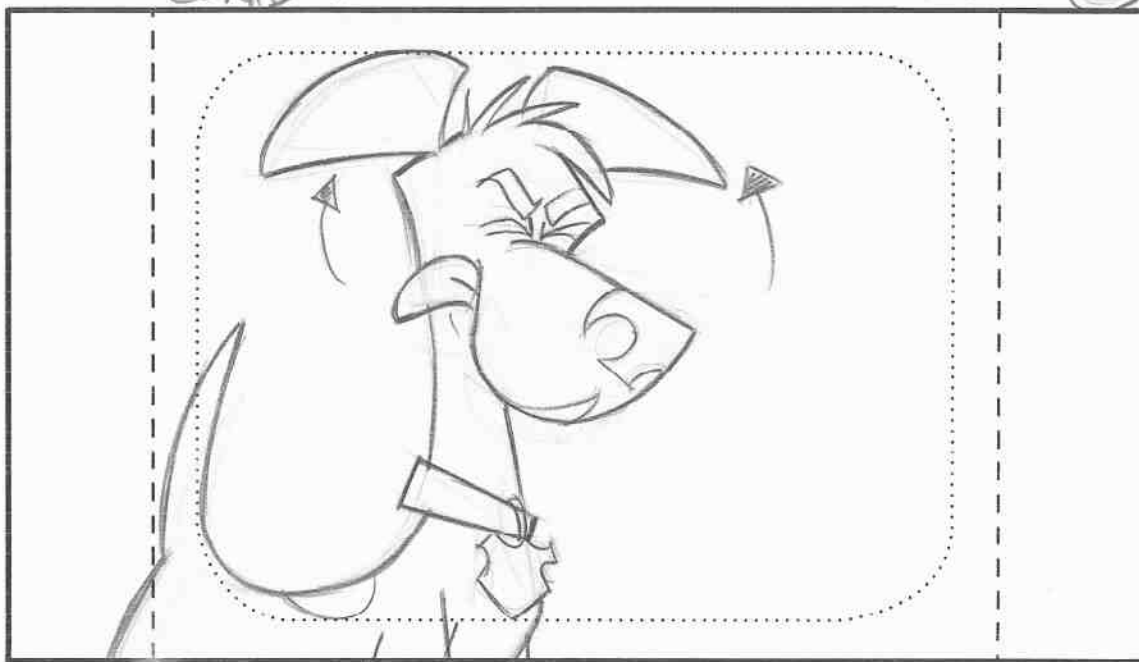

Dialogue Action

SQUIRT FROWNS IN CONCENTRATION. HIS EARS PERK UP.

257-777



FIREHOUSE TALES

©2005 Warner Bros. This Material is the PROPERTY OF WARNER BROS. TELEVISION ANIMATION. It is unpublished and must not be taken from the studio, duplicated or used in any manner, except for production purposes, and may not be sold or transferred.

Sc. 11 CONTD

Panel (D)

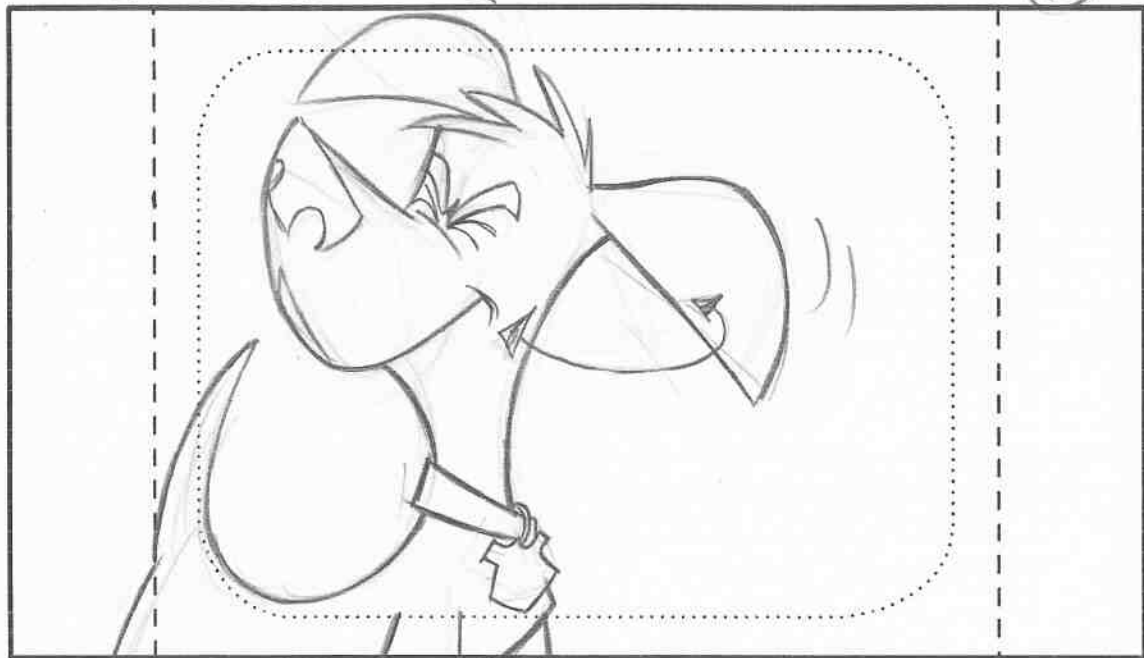

Dialogue Action

SQUIRT'S HEAD TURNS SLOWLY BACK AND FORTH.

Sc. CONTD

Panel (E)



Dialogue Action

SUDDENLY HE STIFFENS.

CUT

257-777



FIREHOUSE TALES

©2005 Warner Bros. This Material is the PROPERTY OF WARNER BROS. TELEVISION ANIMATION. It is unpublished and must not be taken from the studio, duplicated or used in any manner, except for production purposes, and may not be sold or transferred.

Sc. 12

Panel

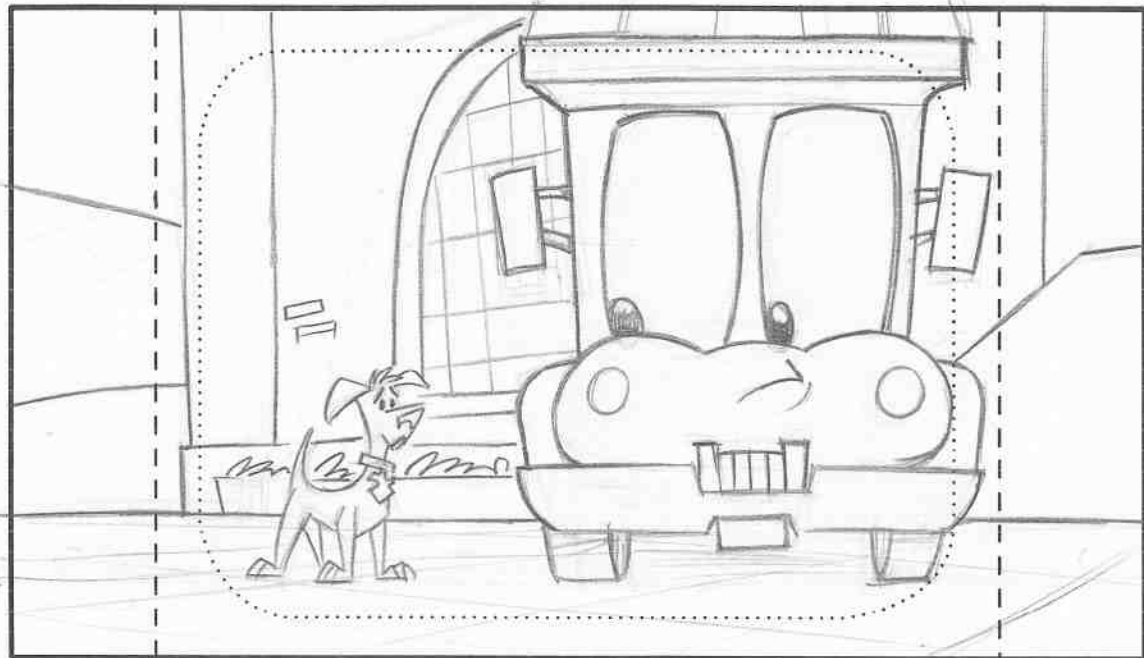

HU

CUT

Dialogue Action

WIDER ON SQUIRT AND RED.

Sc.

CONT'D

Panel B

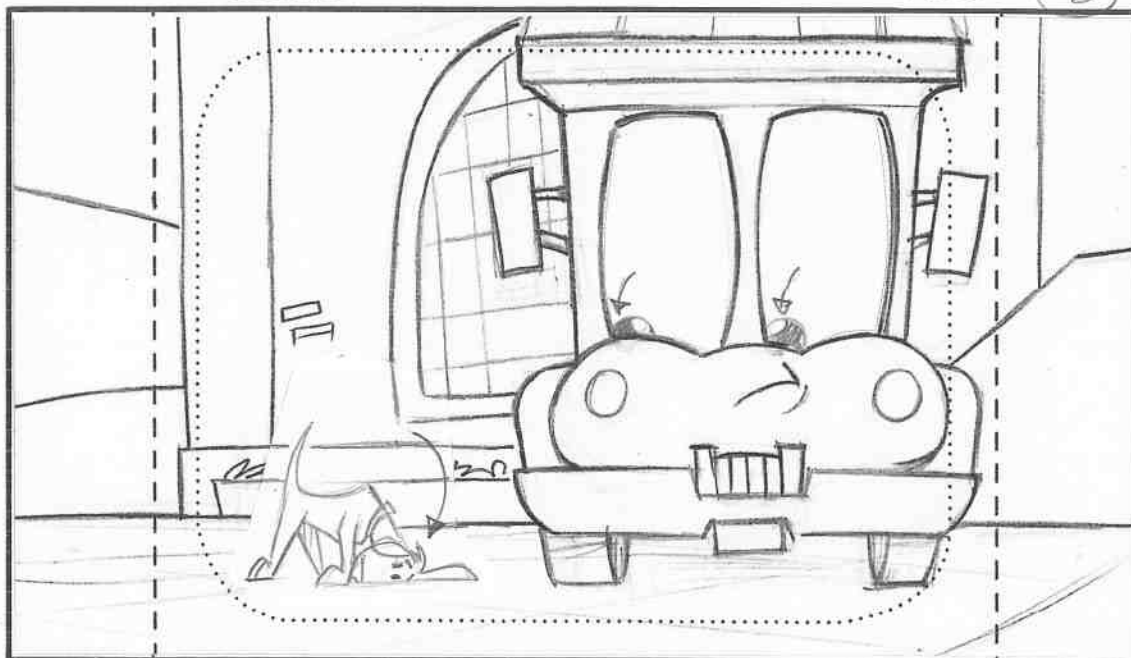

Dialogue Action

SQUIRT PUTS HIS HEAD TO THE GROUND. RED WATCHES HIM.

CUT

257-777



FIREHOUSE TALES

©2005 Warner Bros. This Material is the PROPERTY OF WARNER BROS. TELEVISION ANIMATION. It is unpublished and must not be taken from the studio, duplicated or used in any manner, except for production purposes, and may not be sold or transferred.

Sc. 13

Panel (A)

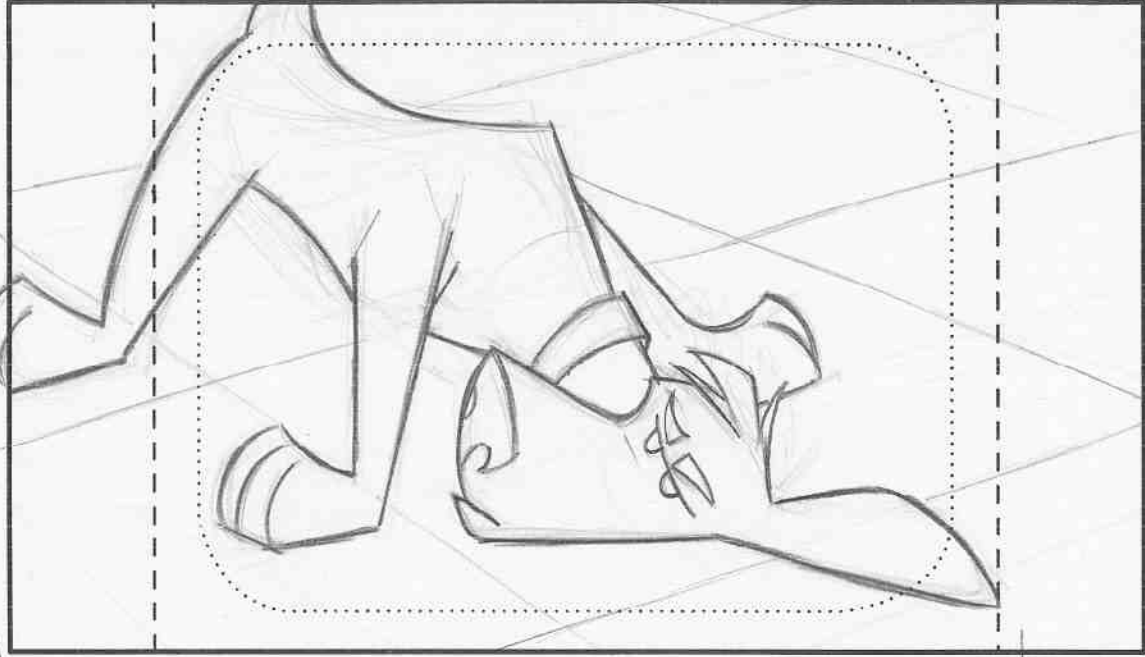

Sc.

CONTD

Panel (B)

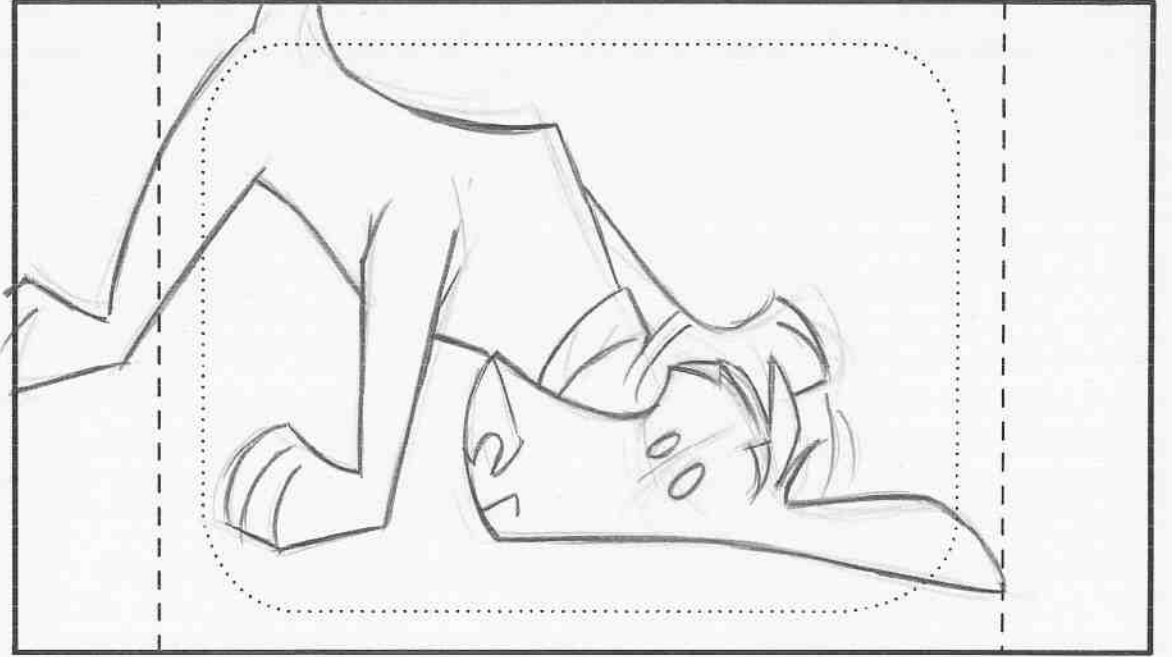

HA

CUT

Dialogue Action

CLOSE ON SQUIRT WITH HIS EAR TO THE GROUND LISTENING INTENTLY.

*GRID FOR REF. ONLY

Dialogue Action

SUDDENLY SQUIRTS EYES WIDEN.

257-777



FIREHOUSE TALES

©2005 Warner Bros. This Material is the PROPERTY OF WARNER BROS. TELEVISION ANIMATION. It is unpublished and must not be taken from the studio, duplicated or used in any manner, except for production purposes, and may not be sold or transferred.

Sc. 13 CONTD

Panel C



SHIFT W/ANIM (A) -> (B) SQUIRT RAISES HIS HEAD

Sc.

Panel B

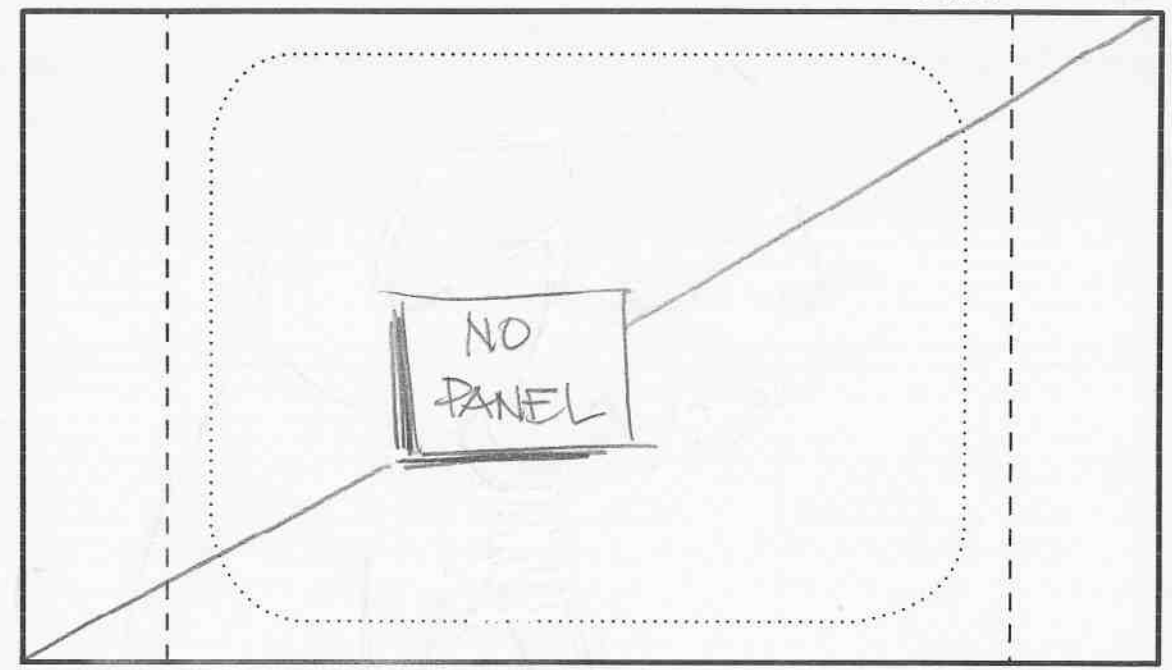

Dialogue Action

⚠ SQUIRT:
<ARF! ARF!>

257-777



FIREHOUSE TALES

©2005 Warner Bros. This Material is the PROPERTY OF WARNER BROS. TELEVISION ANIMATION. It is unpublished and must not be taken from the studio, duplicated or used in any manner, except for production purposes, and may not be sold or transferred.

Sc. 14

S/A B&10 Panel (A)

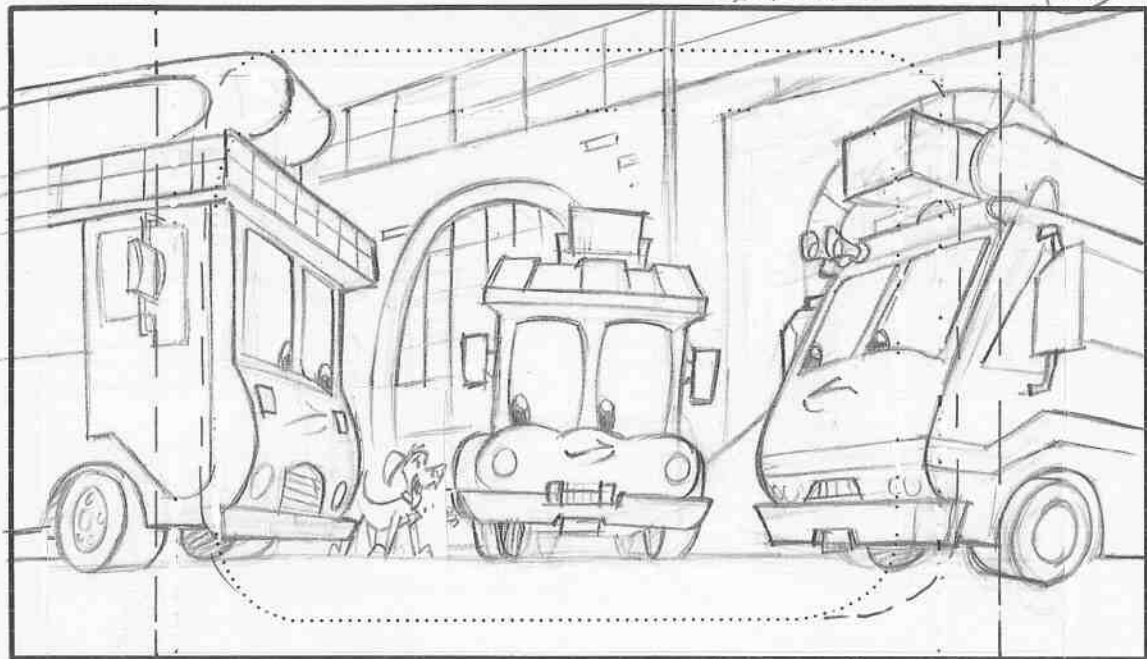

HU

CUT

Dialogue Action

EXT. FIREHOUSE (COURTYARD) (NIGHT)
WIDE ON GROUP.

Sc.

CONTD.

Panel (B)

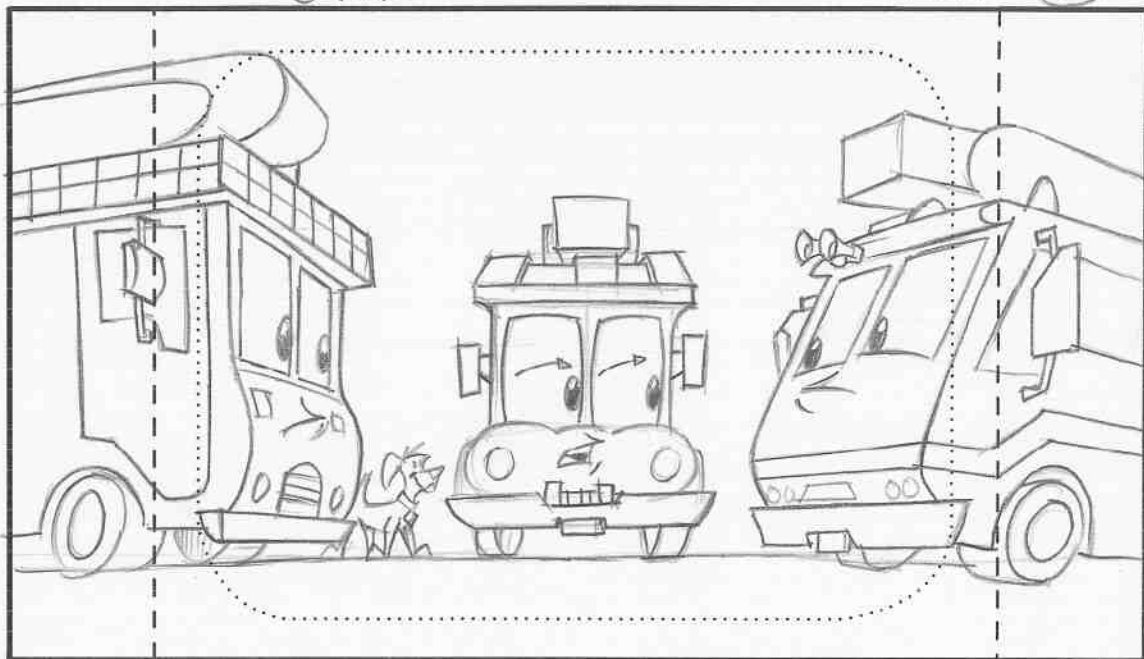

Dialogue Action

RED LOOKS UP OVER AT CRABBY.

(A) RED:

HE SAYS THE NOISE IS COMING FROM UNDERGROUND.

257-777



FIREHOUSE TALES

©2005 Warner Bros. This Material is the PROPERTY OF WARNER BROS. TELEVISION ANIMATION. It is unpublished and must not be taken from the studio, duplicated or used in any manner, except for production purposes, and may not be sold or transferred.

Sc. 14 CONTD.

Panel (C)

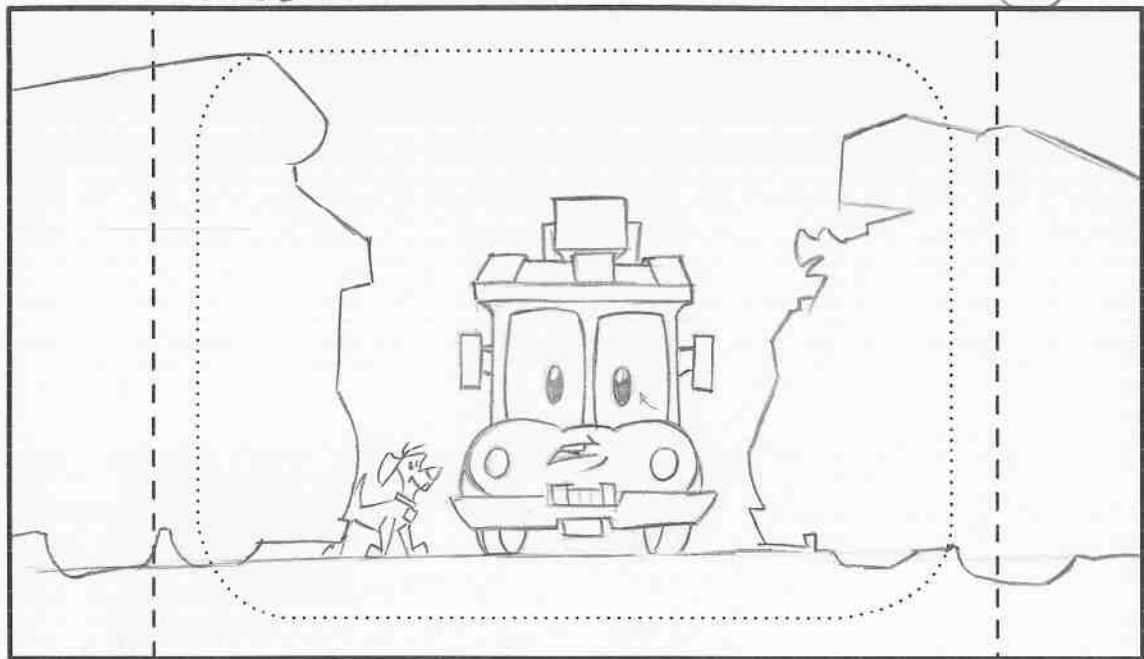

RED LOOKS TO CAMERA

Dialogue Action

(14) RED: (CONTD)

WHAT COULD IT BE?

Sc. 15

Panel (A)

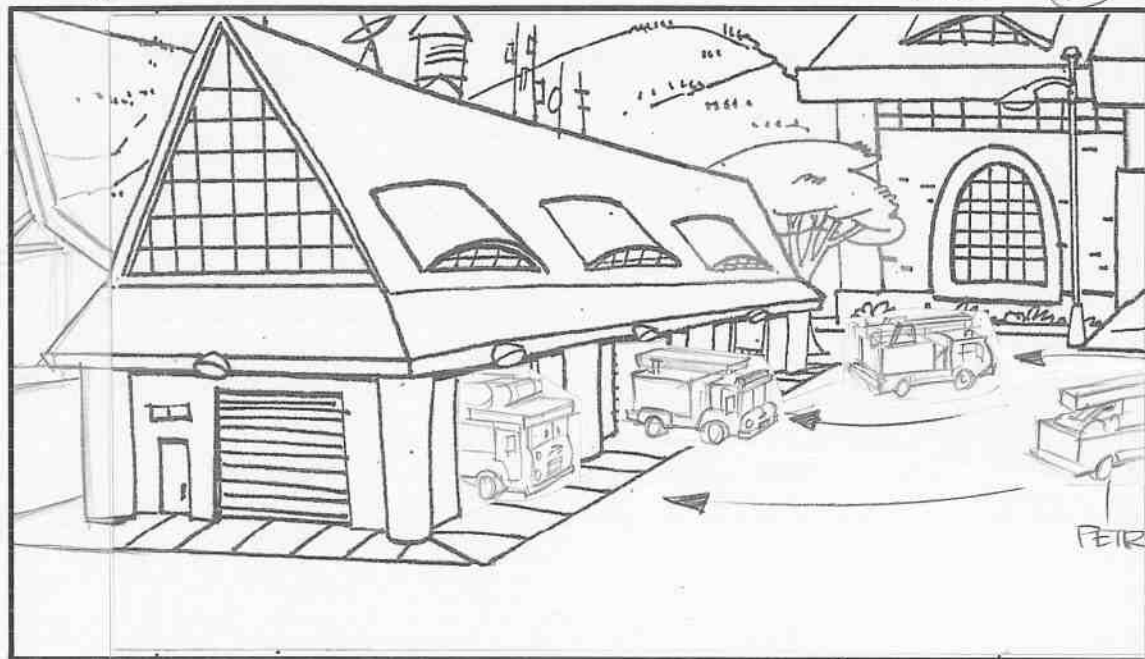

EXT. FIREHOUSE COURTYARD - (NIGHT)
THE TRUCKS BACK INTO THEIR "ROOMS"

SFX: < RUMBLING >

CUT

Dialogue Action

(15) WISER: (VO)

RED HAD ALL NIGHT TO WONDER,
FOR THE MYSTERIOUS NOISE ...

257-777



FIREHOUSE TALES

©2005 Warner Bros. This Material is the PROPERTY OF WARNER BROS. TELEVISION ANIMATION. It is unpublished and must not be taken from the studio, duplicated or used in any manner, except for production purposes, and may not be sold or transferred.

Sc. 15 CONTD.

Panel (B)

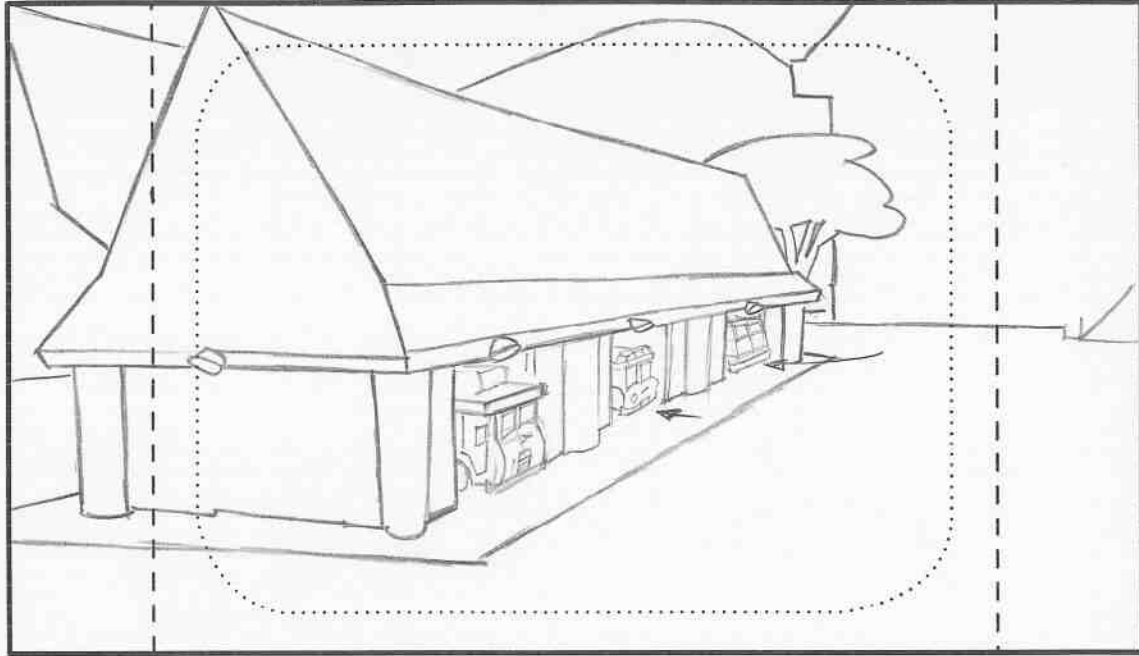

Dialogue Action

THE TRUCKS SETTLE DOWN FOR THE NIGHT, BUT THE RUMBLING CONTINUES.

SFX: <RUMBLING> (CONTD)

(15) WISER: (VO) (CONTD)

... DIDN'T STEP UNTIL ...



Sc. 16

Panel

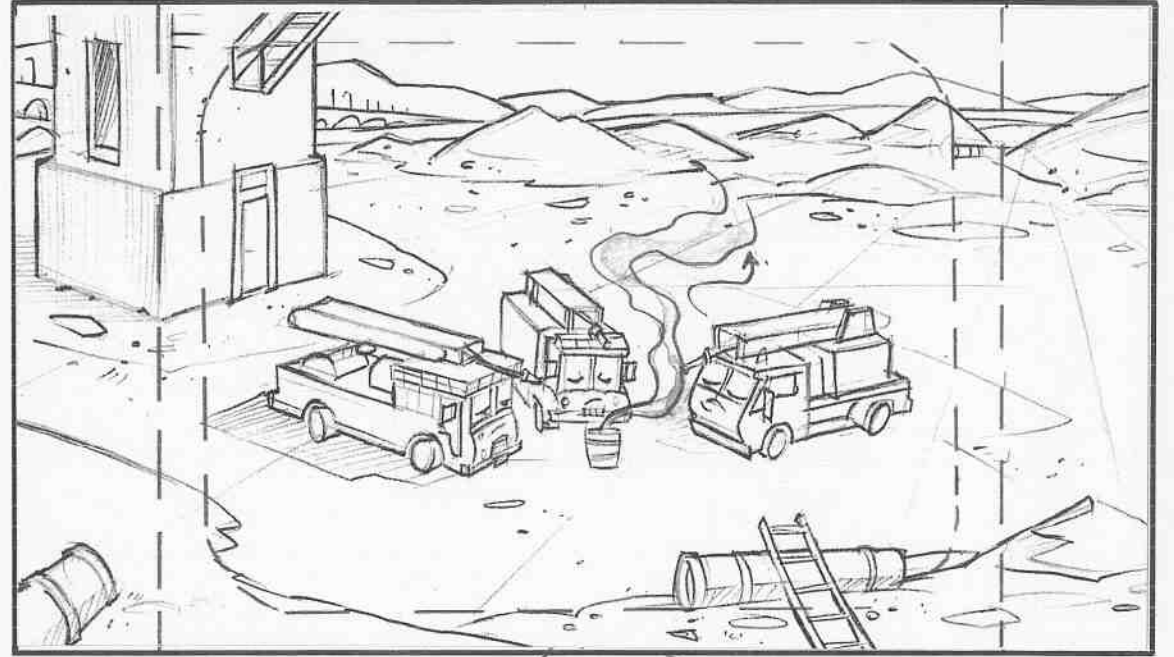

Dialogue Action

EXT. PRACTISE YARD (DAY)

THE SLEEPY TRUCKS STAND AROUND A SMOKING BARREL.

SFX: (DX SMOKE)

CUT

(15) WISER: (VO) CONTD

... THE NEXT MORNING



FIREHOUSE TALES

©2005 Warner Bros. This Material is the PROPERTY OF WARNER BROS. TELEVISION ANIMATION. It is unpublished and must not be taken from the studio, duplicated or used in any manner, except for production purposes, and may not be sold or transferred.

Sc. 17

Panel

Sc.

Panel

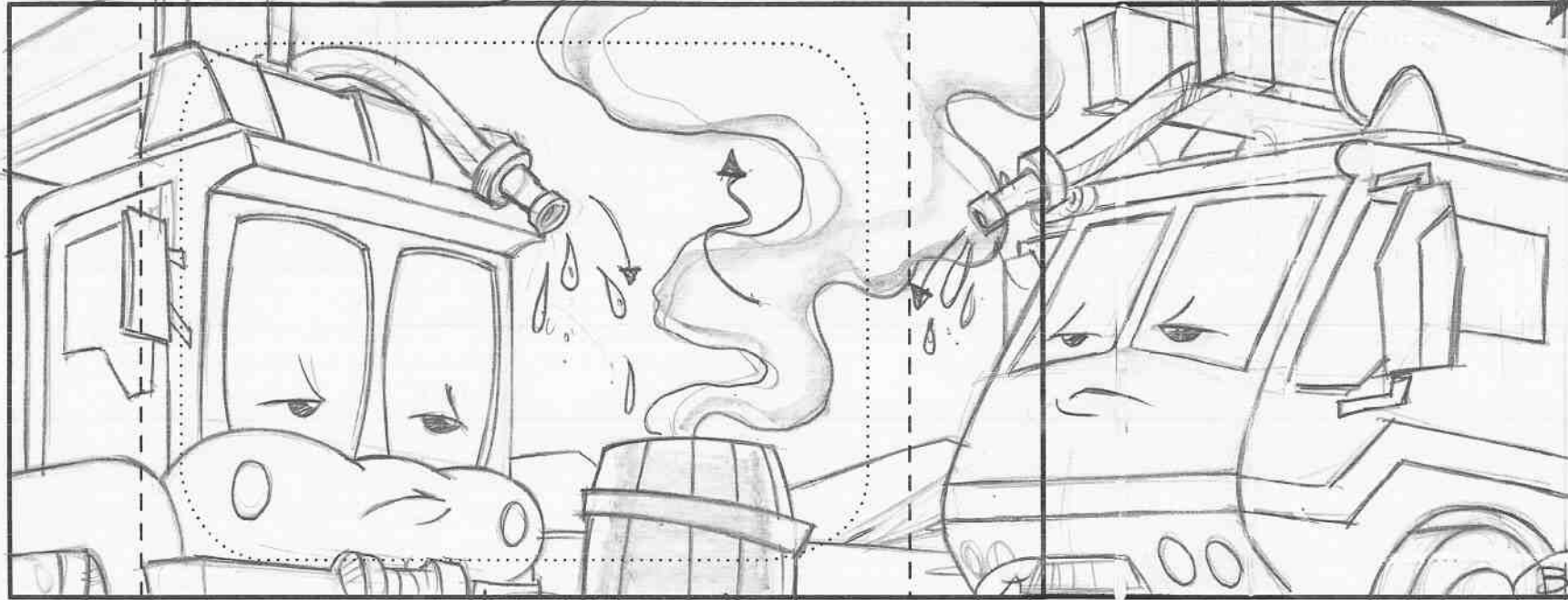

THU

CUT

Dialogue Action

CLOSE ON A VERY SLEEPY RED, HE CAN ONLY MANAGE A COUPLE OF SQUIRT (START) PAN OVER TO CRABBY (STOP)

SFX: (DX SMOKE / ST. DRIPS)

16 WISER: (VO) (CONTD)

..THE TIRED TRUCKS WERE TO POOPED TO PRACTICE.

Dialogue Action

(PAN (A) (B)) HE LOOKS PRETTY TIRED TOO!

257-777



FIREHOUSE TALES

©2005 Warner Bros. This Material is the PROPERTY OF WARNER BROS. TELEVISION ANIMATION. It is unpublished and must not be taken from the studio, duplicated or used in any manner, except for production purposes, and may not be sold or transferred.

Sc. 17 CONTD.

Panel (B)

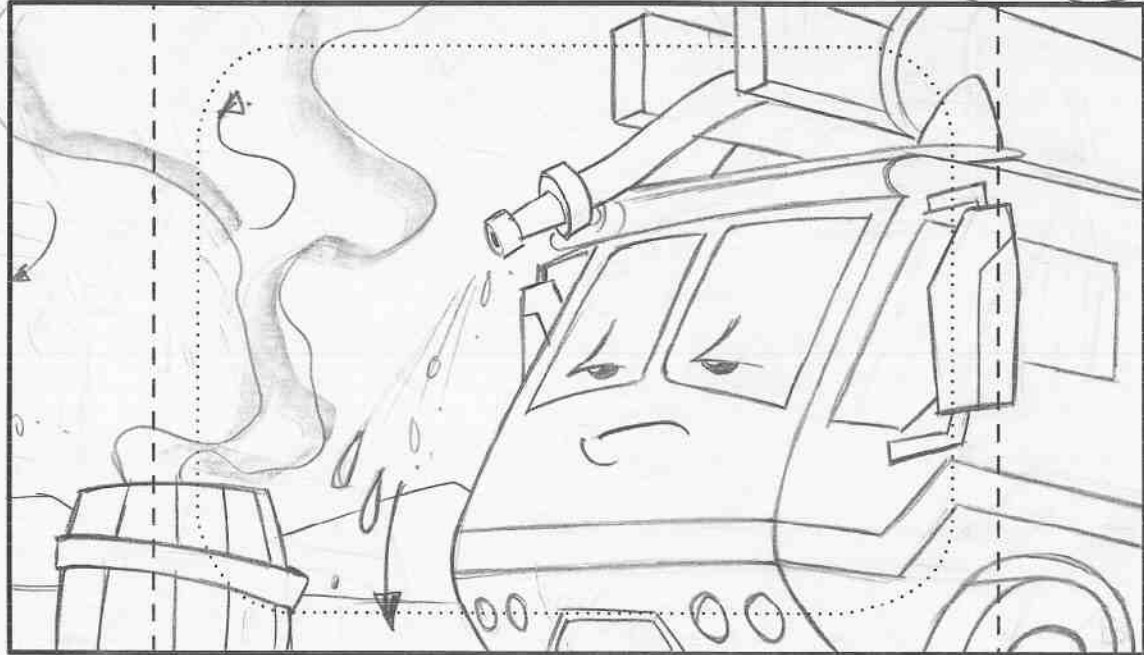

Action RED'S HOSE DROPS OUT OF SCENE. CRABBY SQUIRTS A COUPLE MORE DROPS...

Dialogue

Sc. CONTD.

Panel (C)

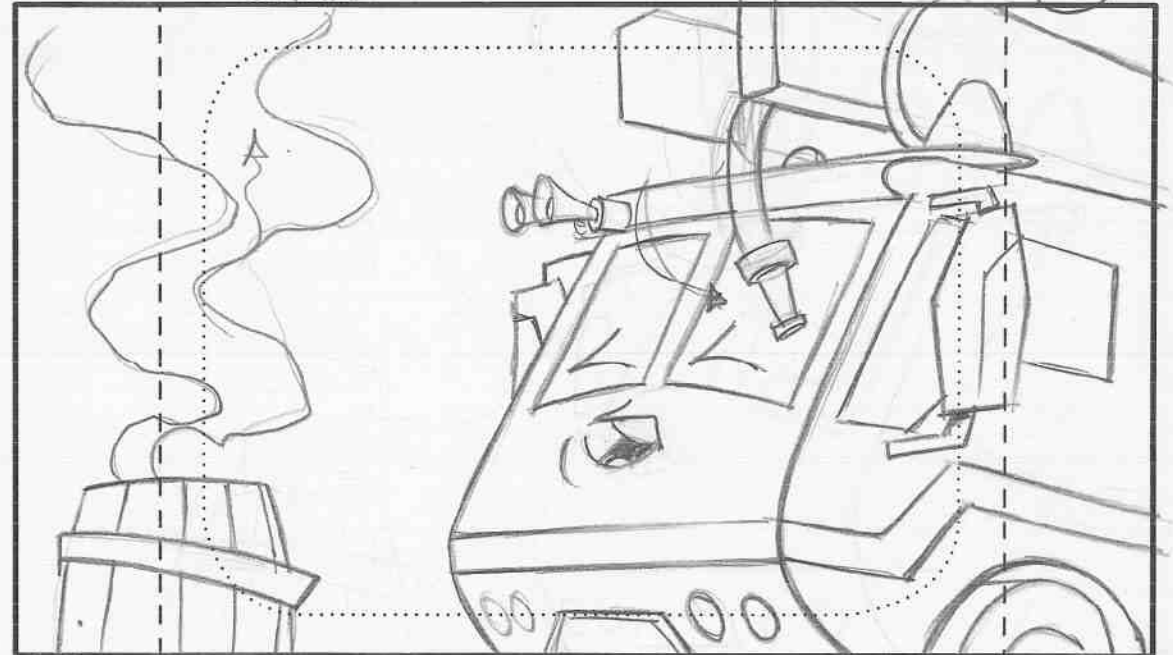

.. THEN FALLS ASLEEP, HE HOSE DROOPS.

(CUT)

Action CRABBY:
<SOFT SNORING.>



FIREHOUSE TALES

©2005 Warner Bros. This Material is the PROPERTY OF WARNER BROS. TELEVISION ANIMATION. It is unpublished and must not be taken from the studio, duplicated or used in any manner, except for production purposes, and may not be sold or transferred.

Sc. 18

Panel

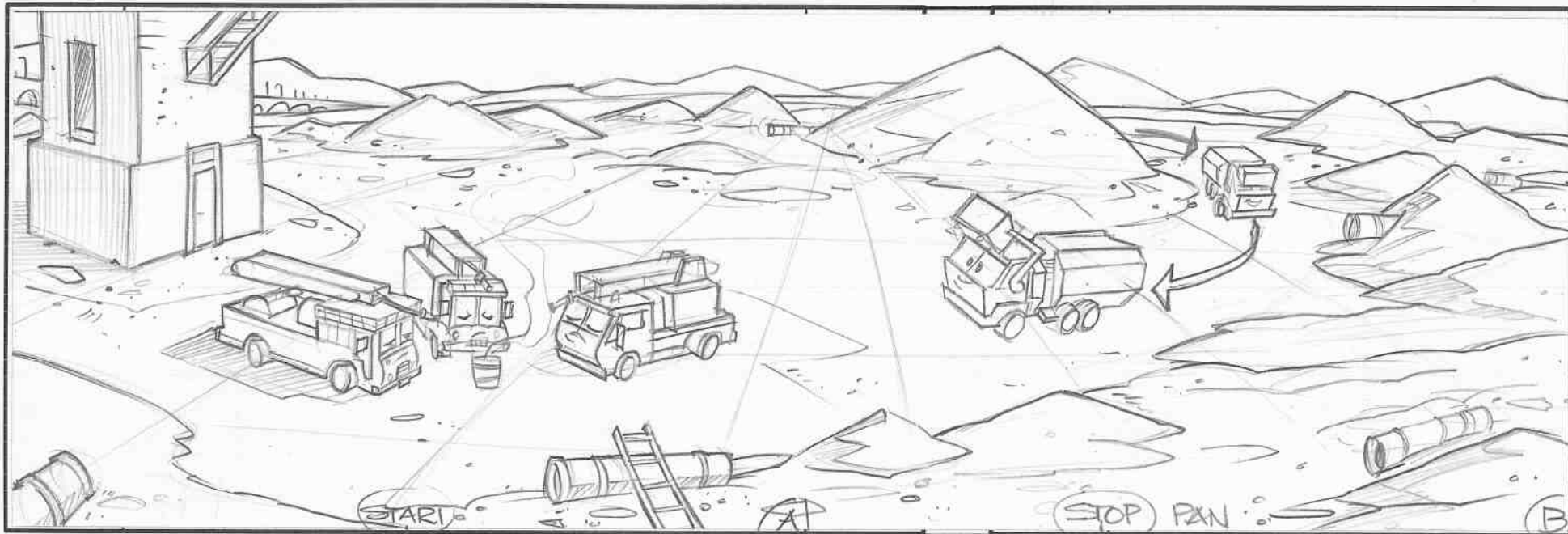

CUT

Dialogue Action

EXT. PRACTISE YARD - DAY

WIDE ON OUR GANG - ALL ASLEEP.
(SMOKE FADES OFF)

PAN (A) → (B)

EFF (BY SMOKE)

Dialogue Action

STINKY ENTERS CARRYING A DUMPSTER.
HE ROLLS TOWARDS THE SLEEPING TRUCKS.

CUT

(17) STINKY:

DUM DE DUM ~~~~~>

257-777



FIREHOUSE TALES

©2005 Warner Bros. This Material is the PROPERTY OF WARNER BROS. TELEVISION ANIMATION. It is unpublished and must not be taken from the studio, duplicated or used in any manner, except for production purposes, and may not be sold or transferred.

Sc. 19

Panel

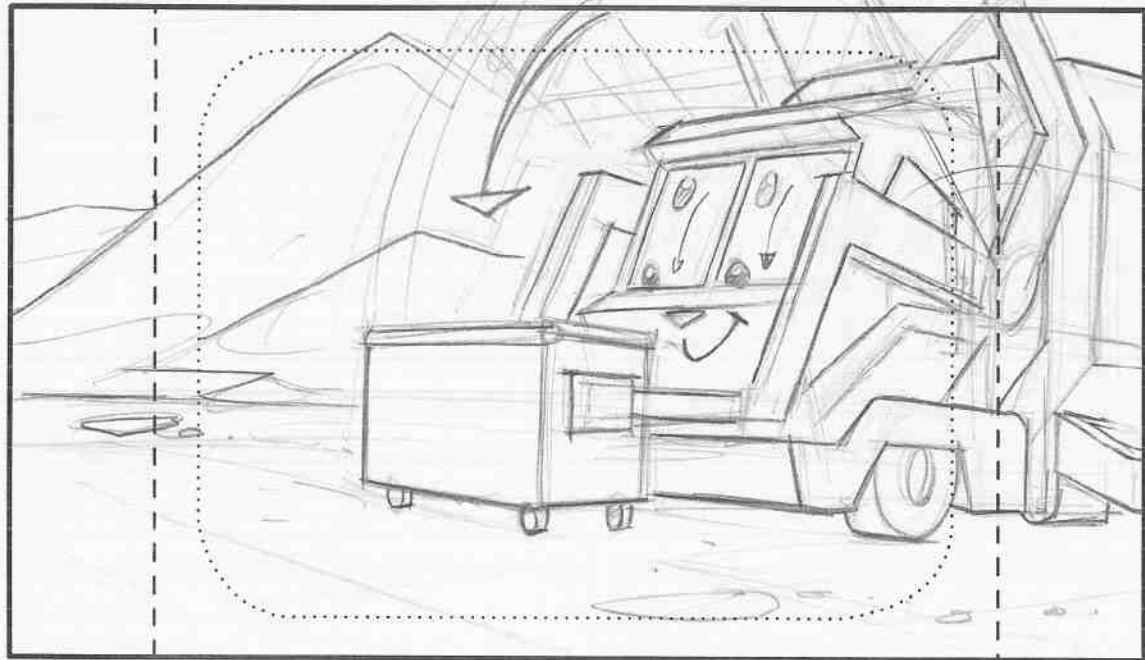

CUT

Dialogue Action ANGLE ON STINKY HE STARTS TO PUT THE DUMPSTER DOWN.

CUT

Sc. 20

Panel

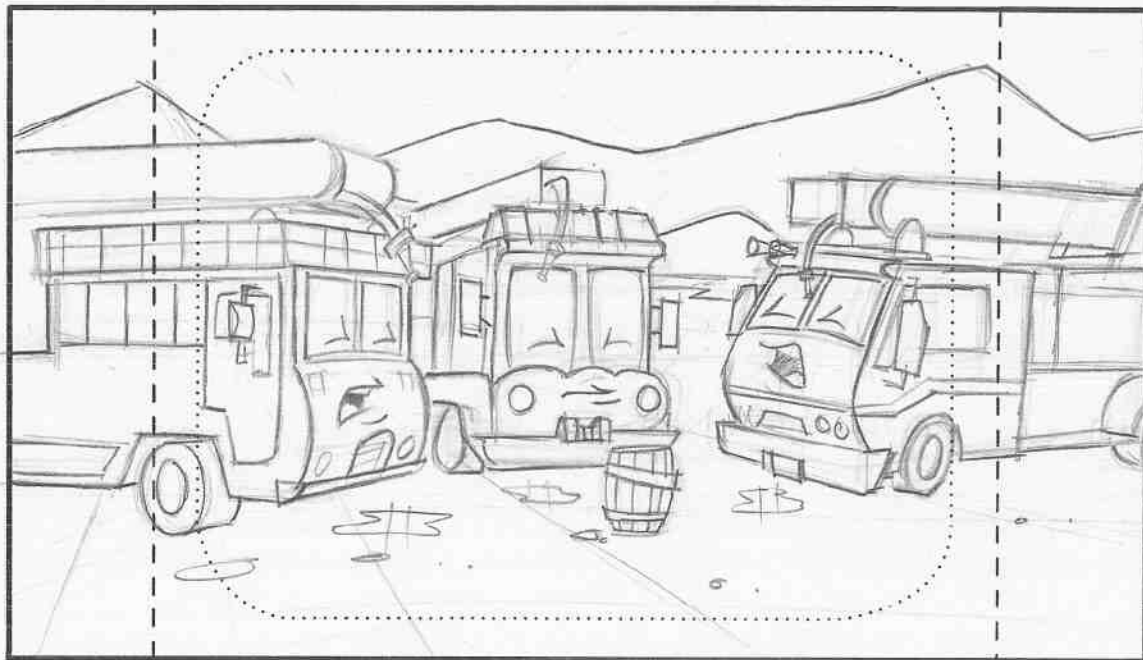

Dialogue Action ANGLE ON SLEEPING FIRETRUCKS

257-777



FIREHOUSE TALES

©2005 Warner Bros. This Material is the PROPERTY OF WARNER BROS. TELEVISION ANIMATION. It is unpublished and must not be taken from the studio, duplicated or used in any manner, except for production purposes, and may not be sold or transferred.

Sc. 20 CONTD.

Panel B.

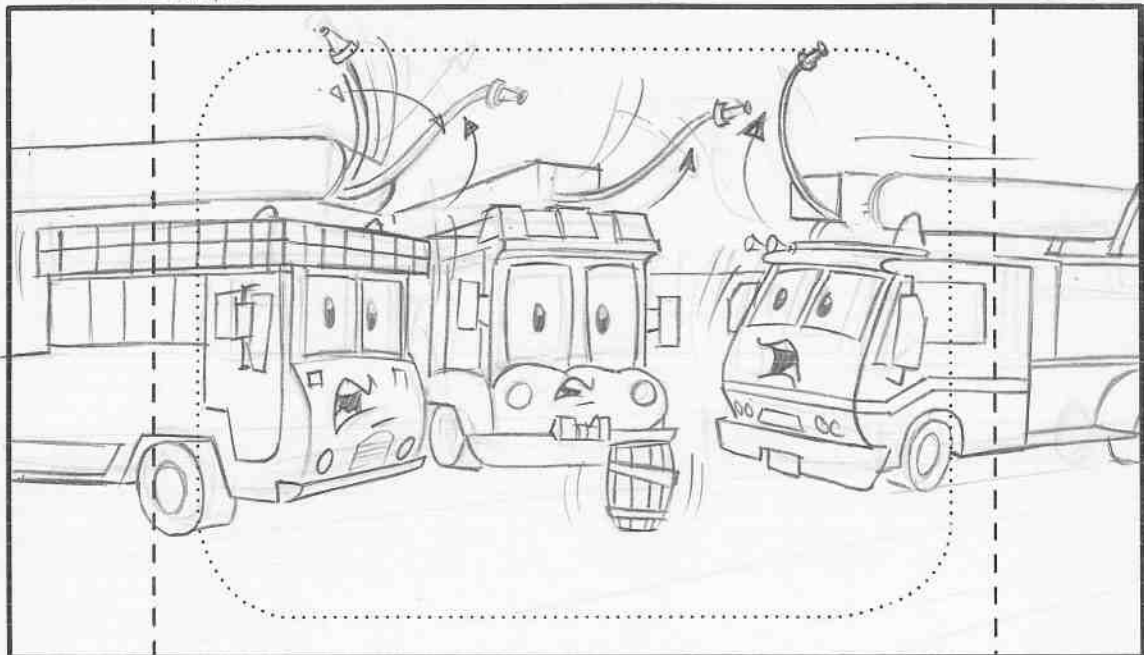

Action THE BANGING OF THE O.S DUMPSTER STARTLES OUR GANG AWAKE

CUT

Dialogue SFX: <BANG> (CS)
⑱ RED/PETROL/CRABBY:
(CRIES OF SURPRISE !)

Sc. 21

SA 19 Panel

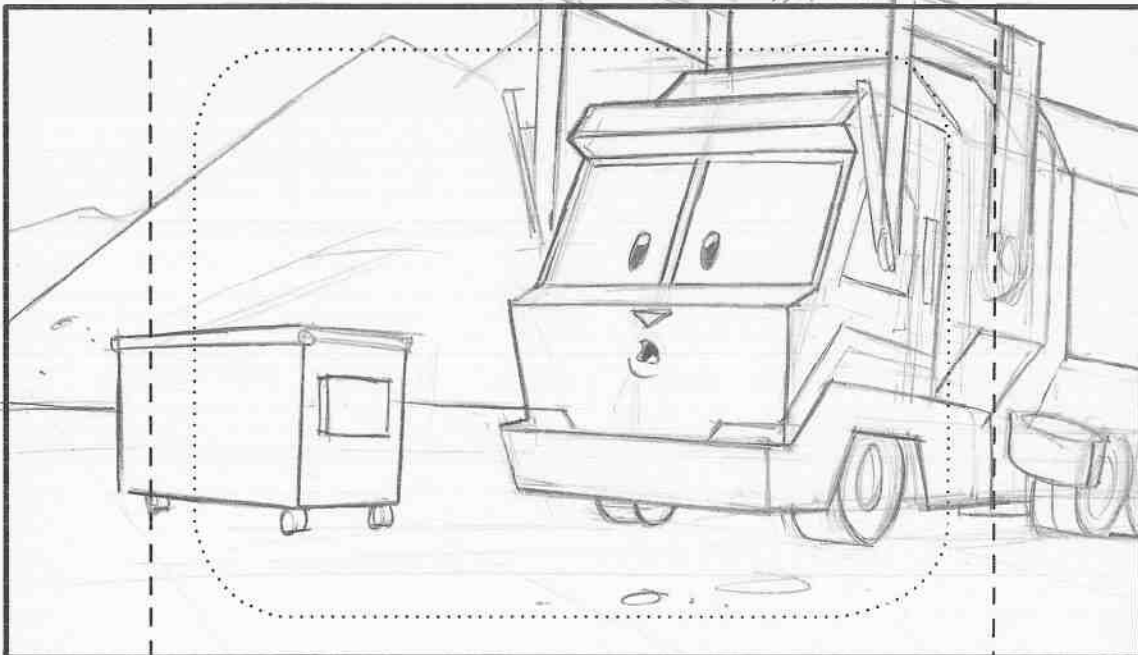

Action ANGLE ON STINKY, LOOKING SURPRISED

CUT

Dialogue ⑲ STINKY:
HEY WHAT'S THE MATTER?



FIREHOUSE TALES

©2005 Warner Bros. This Material is the PROPERTY OF WARNER BROS. TELEVISION ANIMATION. It is unpublished and must not be taken from the studio, duplicated or used in any manner, except for production purposes, and may not be sold or transferred.

Sc. 22

Panel

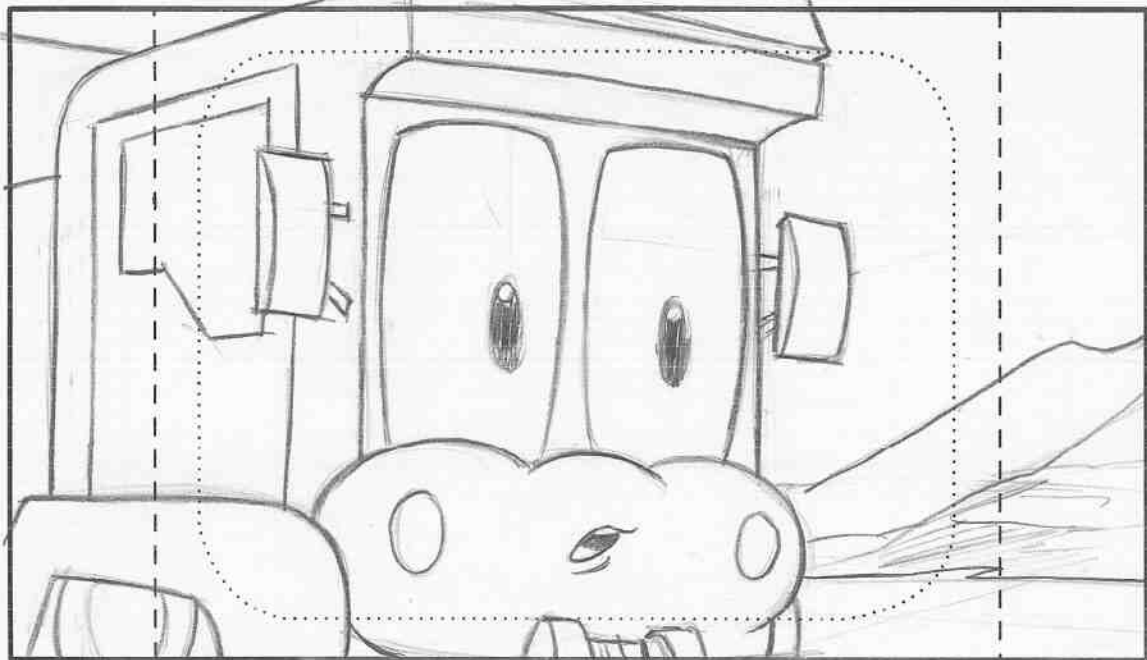

CUT

CLOSE ON RED.

Dialogue Action

(20) RED:

SORRY STINKY WE DIDNT GET ANY SLEEP LAST NIGHT BECAUSE OF A LOUD NOISE.

CUT

Sc. 23

Panel

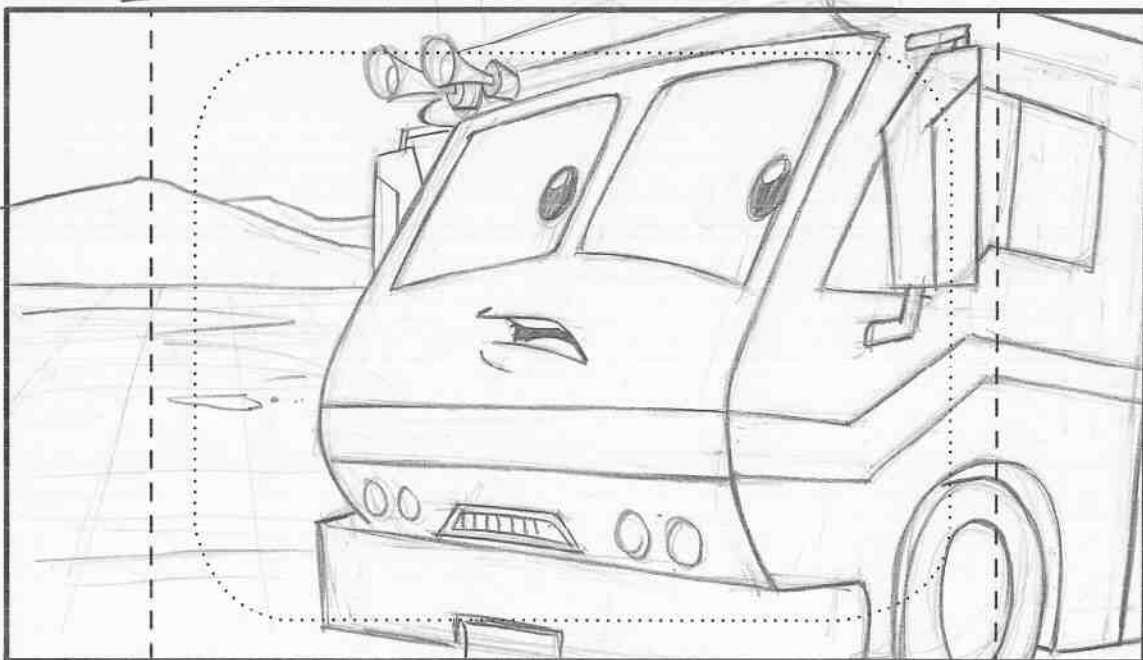

CLOSE ON CRABBY.

Dialogue Action

(21) CRABBY:

YEAH IT CAME FROM UNDERGROUND. WHAT A RACKET!

CUT

257-777



FIREHOUSE TALES

©2005 Warner Bros. This Material is the PROPERTY OF WARNER BROS. TELEVISION ANIMATION. It is unpublished and must not be taken from the studio, duplicated or used in any manner, except for production purposes, and may not be sold or transferred.

Sc. 24

Panel

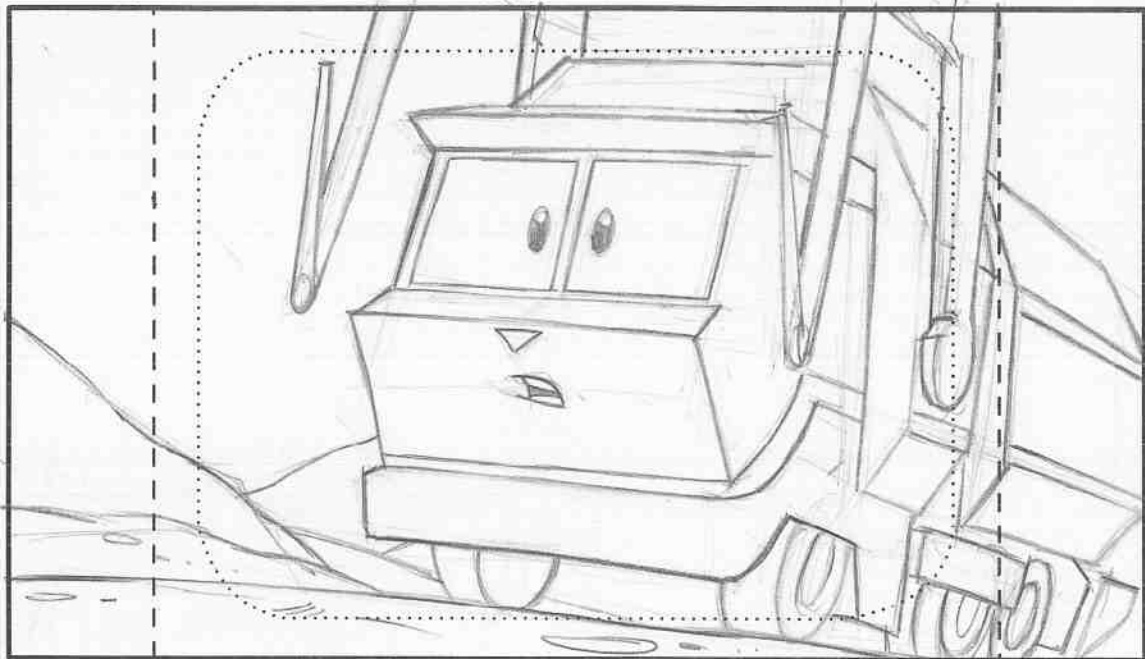

cut

Dialogue Action

ANGLE ON STINKY.

(22) STINKY:

HMM.. I HEAR THEY'RE DIGGING TUNNELS

AT..

Sc. CONTD.

Panel (B)

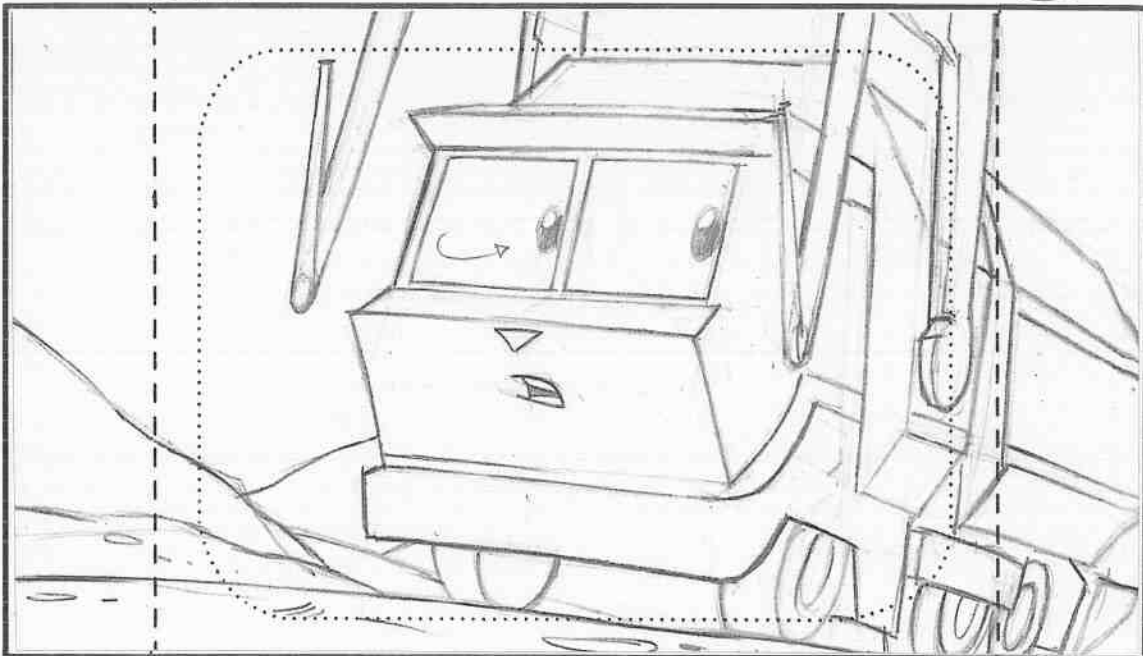

Dialogue Action

STINKY'S EYES SHIFT.

(22) STINKY: (CONTD)

.. THE NORTH END OF TOWN.



FIREHOUSE TALES

©2005 Warner Bros. This Material is the PROPERTY OF WARNER BROS. TELEVISION ANIMATION. It is unpublished and must not be taken from the studio, duplicated or used in any manner, except for production purposes, and may not be sold or transferred.

Sc. 24 CONTD.

Panel C

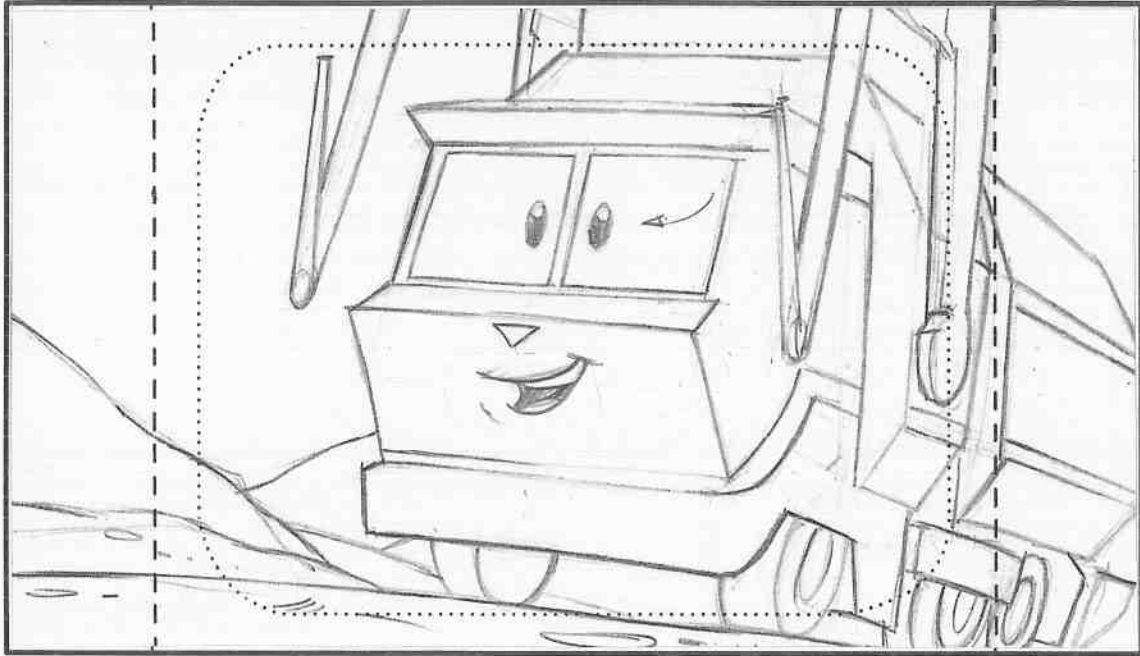

Dialogue Action

STINKY LOOKS BACK AT THE OS TRUCKS SMILING.

(22) STINKY: (CONTD).

MAYBE THAT'S WHERE YOUR NOISE IS COMING FROM.

Sc. CONTD.

Panel D

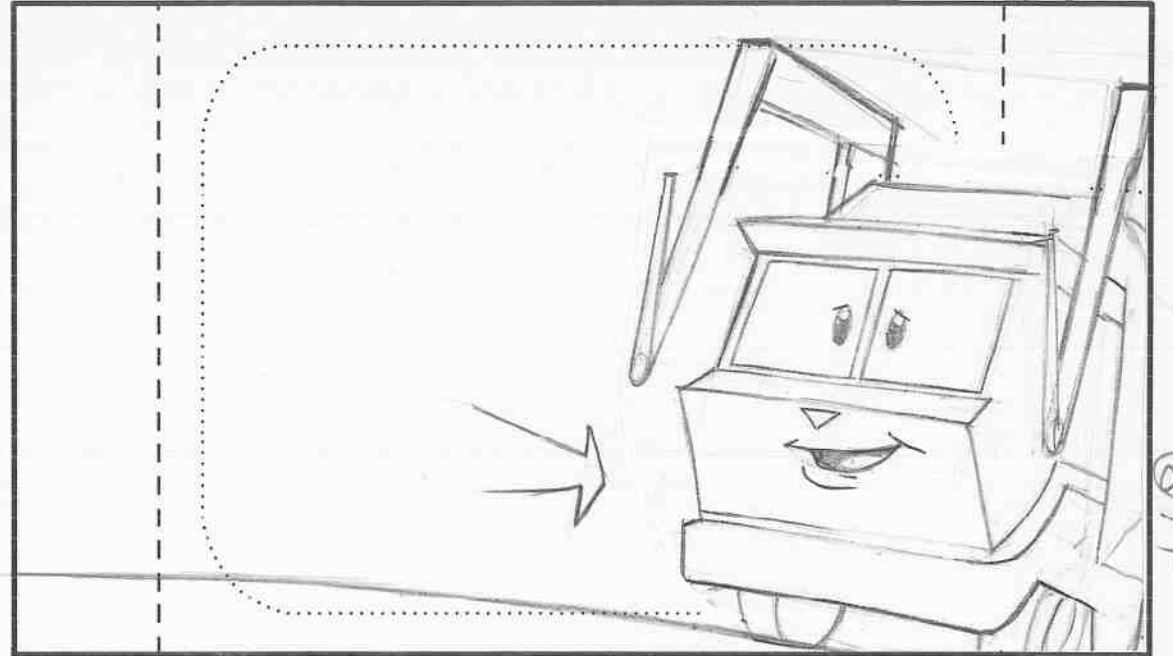

Dialogue Action

STINKY BACKS OUT HUMMING

(22) STINKY:

DUM-DE-DUM-DUM..



FIREHOUSE TALES

©2005 Warner Bros. This Material is the PROPERTY OF WARNER BROS. TELEVISION ANIMATION. It is unpublished and must not be taken from the studio, duplicated or used in any manner, except for production purposes, and may not be sold or transferred.

Sc. 25

SA BG-20 Panel

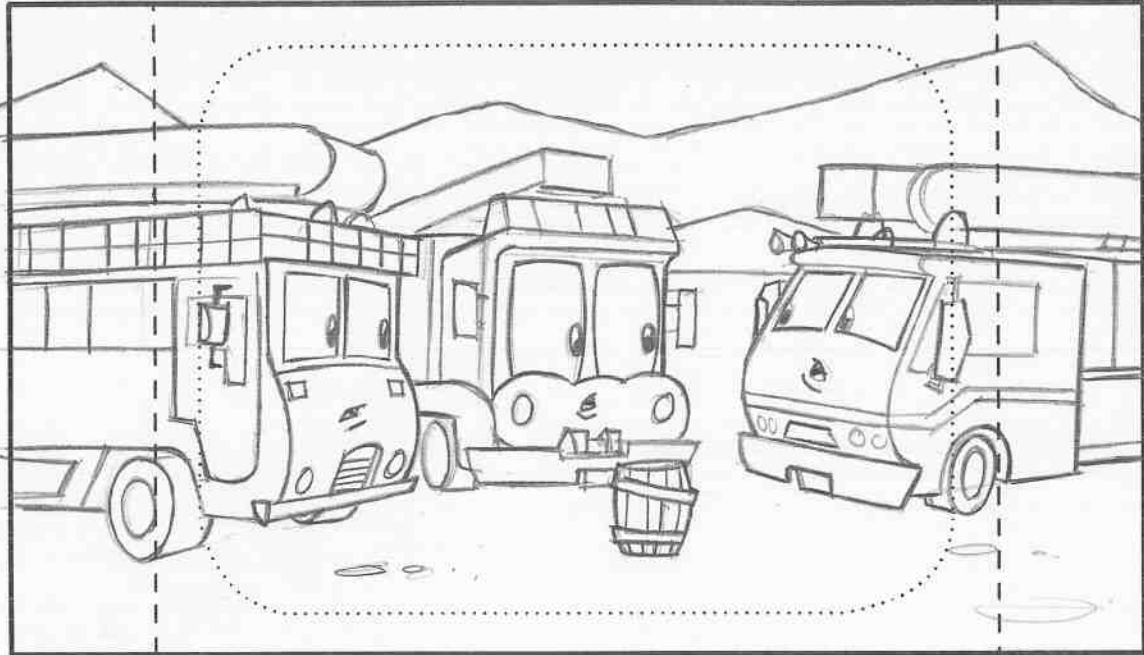

WIDE ON OUR HEROS. THEY EXCHANGE LOOKS. X-DISS

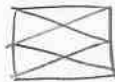

Dialogue Action

CUT

Sc. 26

Panel

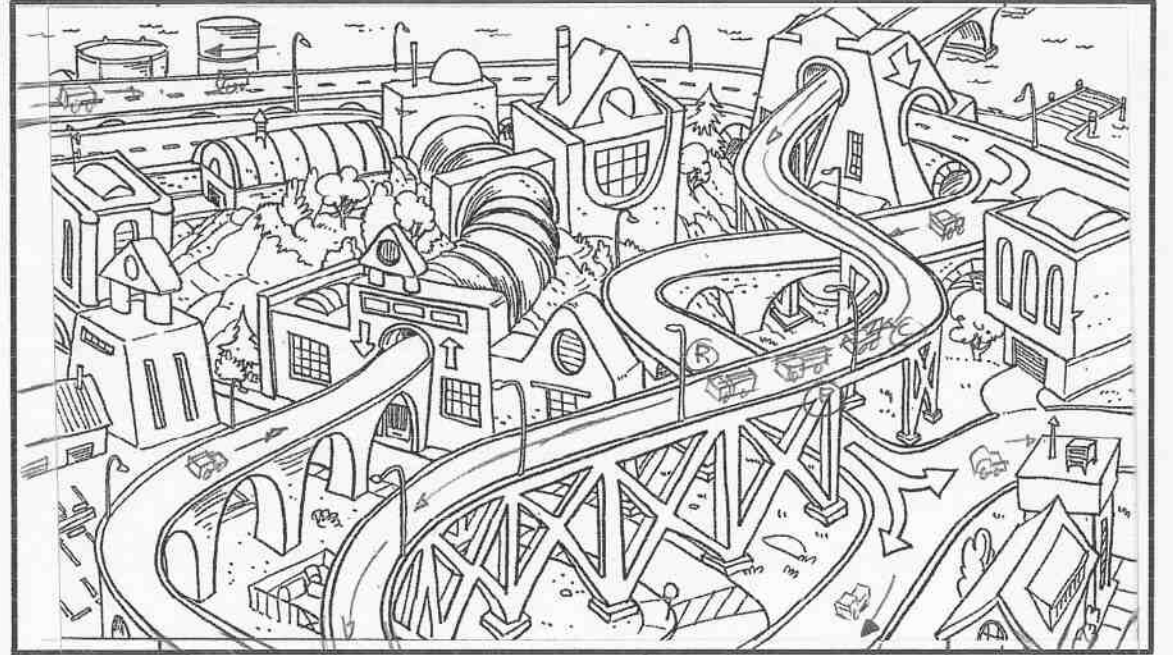

EXT. ELEVATED ROADS 2 (DAY)

RED, PETROL & CRABBY DRIVE ALONG THE ROADWAY

CUT

Dialogue Action

257-777



FIREHOUSE TALES

©2005 Warner Bros. This Material is the PROPERTY OF WARNER BROS. TELEVISION ANIMATION. It is unpublished and must not be taken from the studio, duplicated or used in any manner, except for production purposes, and may not be sold or transferred.

Sc. 27

Panel

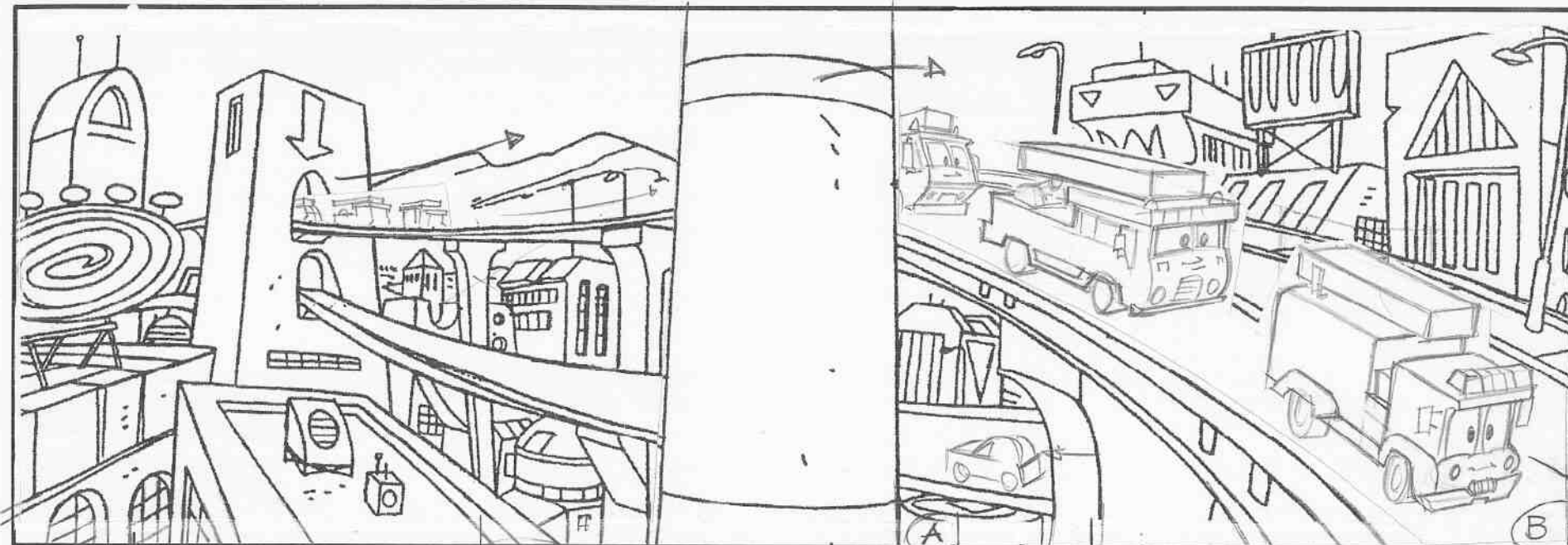

CUT

Dialogue Action
EXT. CITY TWO-LEVEL FREEWAY - (DAY)
PAN W/ANIM (A) → (B) OUR TRUCKS DRIVE ALONG THE FREEWAY

Dialogue Action

CUT

CUT

257-777



FIREHOUSE TALES

©2005 Warner Bros. This Material is the PROPERTY OF WARNER BROS. TELEVISION ANIMATION. It is unpublished and must not be taken from the studio, duplicated or used in any manner, except for production purposes, and may not be sold or transferred.

Sc. 28

Panel

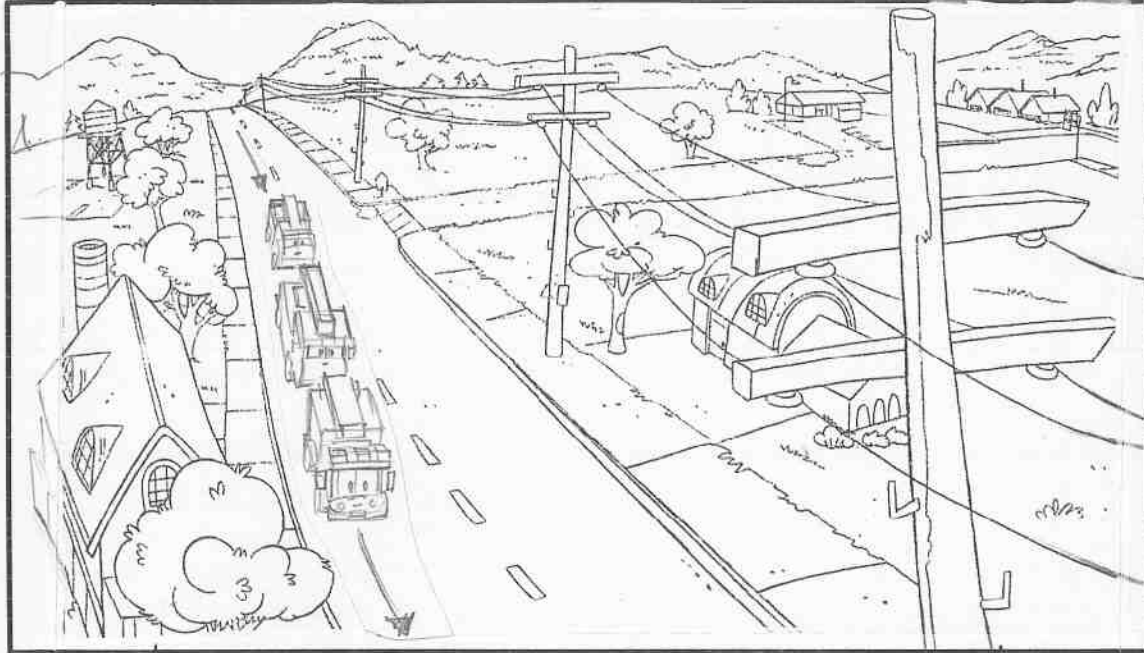

Sc.

Panel

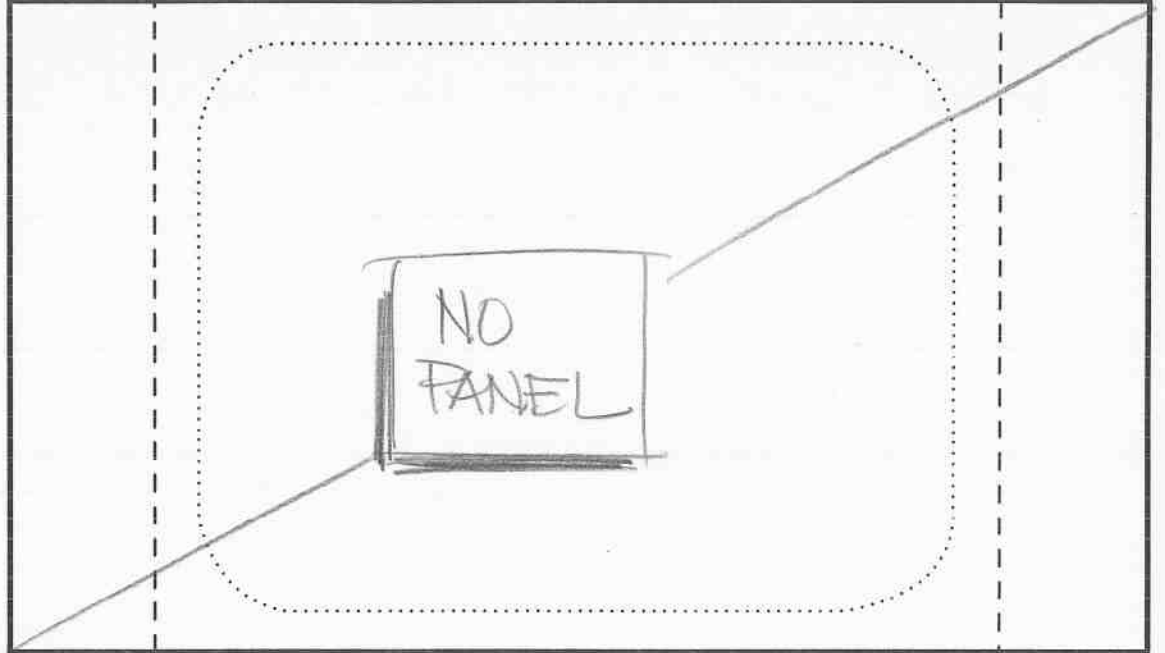

CUT

Action EXT STREET WITH TELEPHONE POLES - DAY
THE TRUCKS CONTINUE TO DRIVE ALONG THE STREETS.

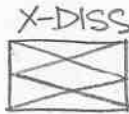

Dialogue (23) WISER: (VO)
SO, THE THREE JUNIOR FIRE TRUCKS
DROVE NORTH

Action



FIREHOUSE TALES

©2005 Warner Bros. This Material is the PROPERTY OF WARNER BROS. TELEVISION ANIMATION. It is unpublished and must not be taken from the studio, duplicated or used in any manner, except for production purposes, and may not be sold or transferred.

Sc. 29

Panel

Sc.

Panel

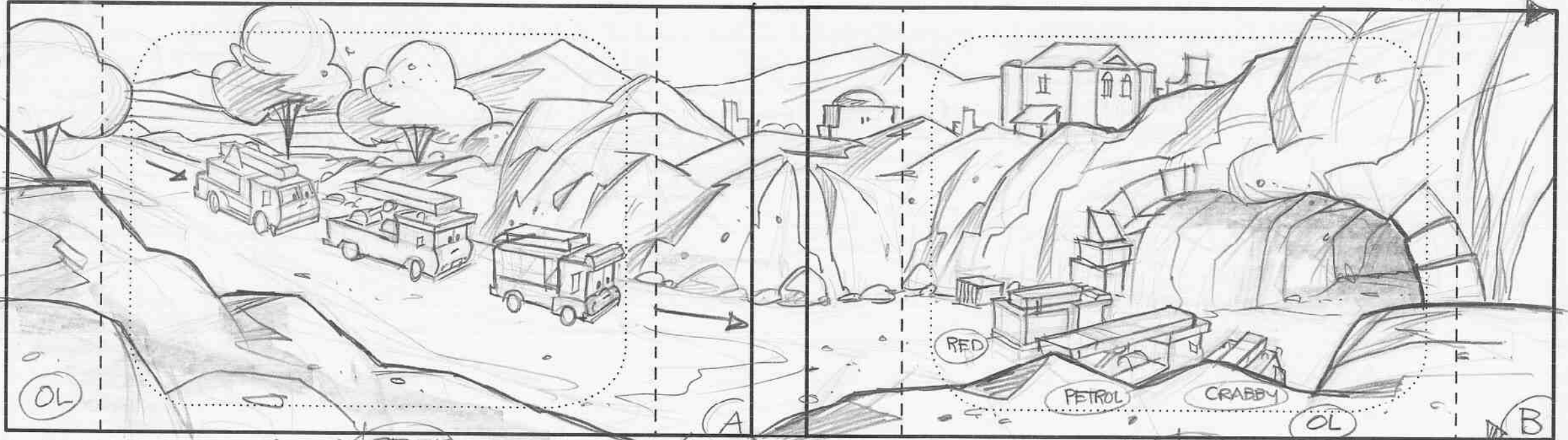

X-DISS FROM

Action

EXT. TUNNEL - (DAY) START (PAN) →

RED, PETROL & CRABBY DRIVE TOWARDS A HUGE TUNNEL ENTRANCE.

PAN W/ANIM (A) → (B)

(23) WISER: (VO) (CONTD)

.. WHERE THEY FOUND A GIANT ..

Action

→ STOP (CUT)

THEY STOP NEAR THE ENTRANCE OF A LARGE TUNNEL.

(23) WISER: (VO) CONTD.

..AND MYSTERIOUS TUNNEL

257-777



FIREHOUSE TALES

©2005 Warner Bros. This Material is the PROPERTY OF WARNER BROS. TELEVISION ANIMATION. It is unpublished and must not be taken from the studio, duplicated or used in any manner, except for production purposes, and may not be sold or transferred.

Sc. 30

Panel

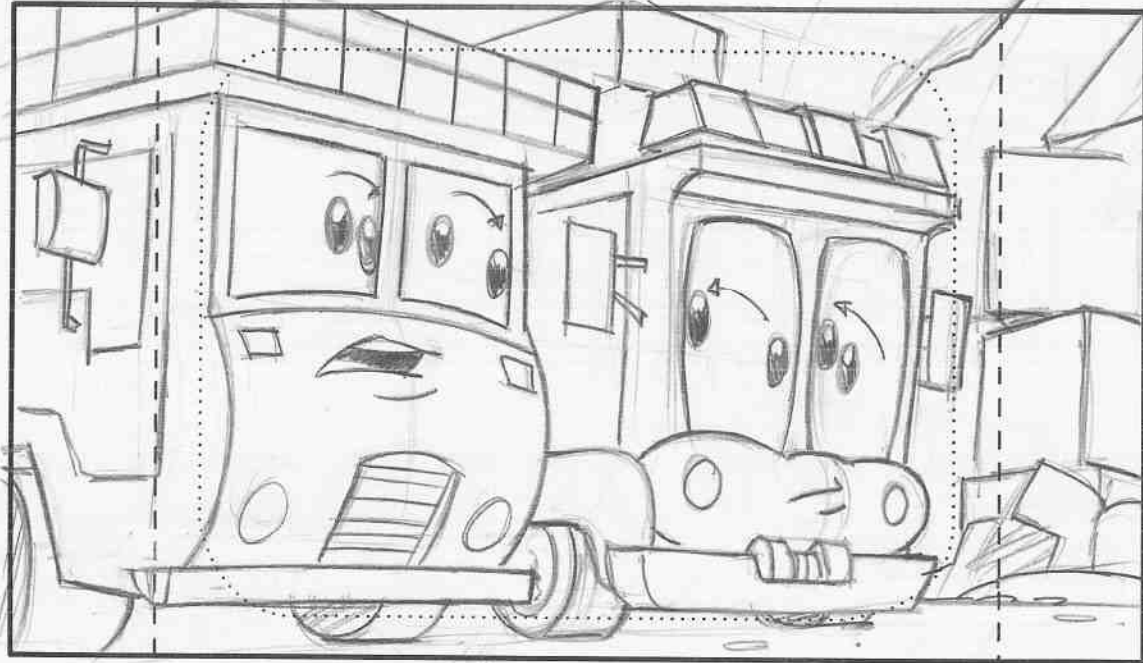

CLOSE ON PETROL & RED. THEY LOOK AT EACH OTHER.

CUT

Dialogue Action

(24) PETROL: (QUIVERING)

OH MY GOODNESS! WHAT COULD'VE DONE THIS?

Sc. 31

Panel (A)

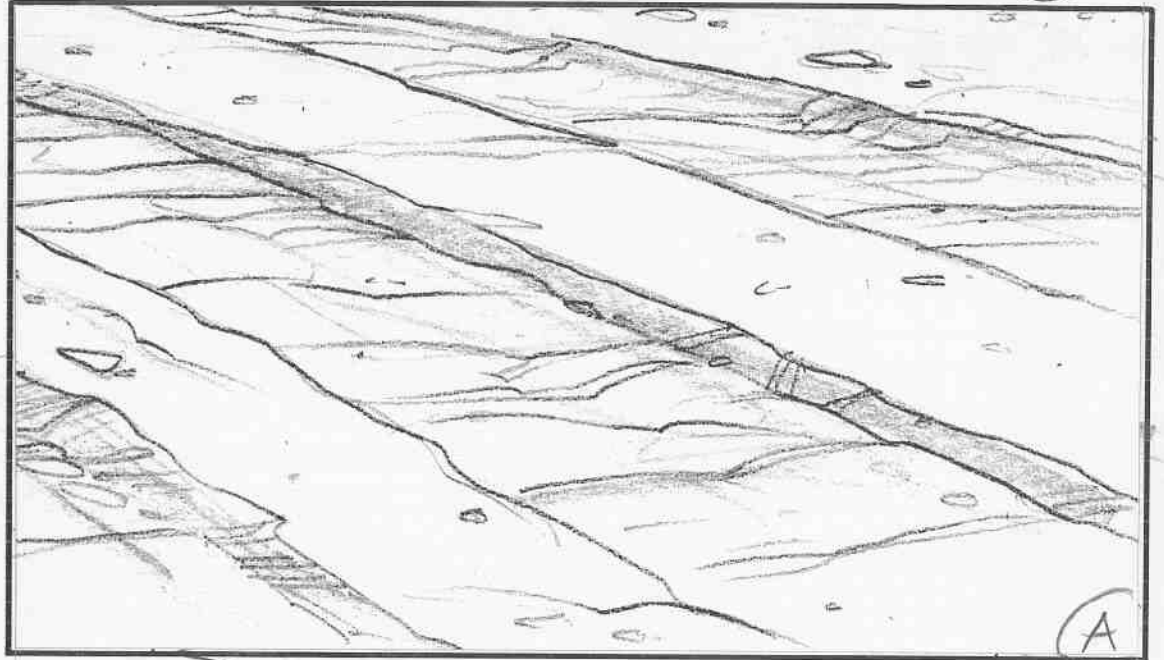

ANGLE ON HUGE TIRE TRACKS.

CUT

Dialogue Action



FIREHOUSE TALES

©2005 Warner Bros. This Material is the PROPERTY OF WARNER BROS. TELEVISION ANIMATION. It is unpublished and must not be taken from the studio, duplicated or used in any manner, except for production purposes, and may not be sold or transferred.

Sc. 31 CONTD.

Panel

(B)

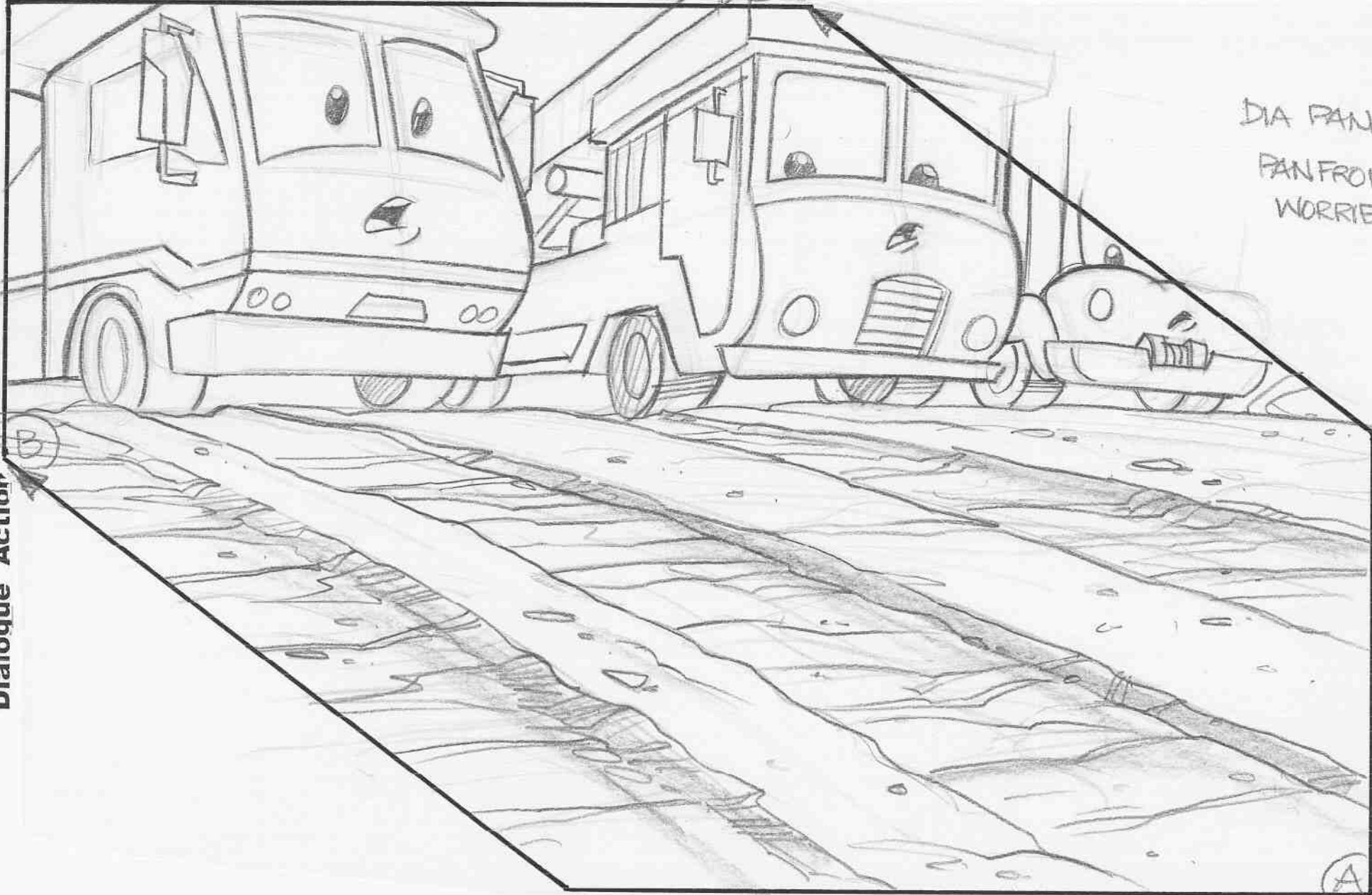

DIA PAN FROM (A) → (B)
PAN FROM TRACKS TO A
WORRIED LOOKING CRABBY!

Dialogue Action

(25) CRABBY!
SOMETHING BIG!
CUT

257-777

(A)



FIREHOUSE TALES

©2005 Warner Bros. This Material is the PROPERTY OF WARNER BROS. TELEVISION ANIMATION. It is unpublished and must not be taken from the studio, duplicated or used in any manner, except for production purposes, and may not be sold or transferred.

Sc. 32

Panel

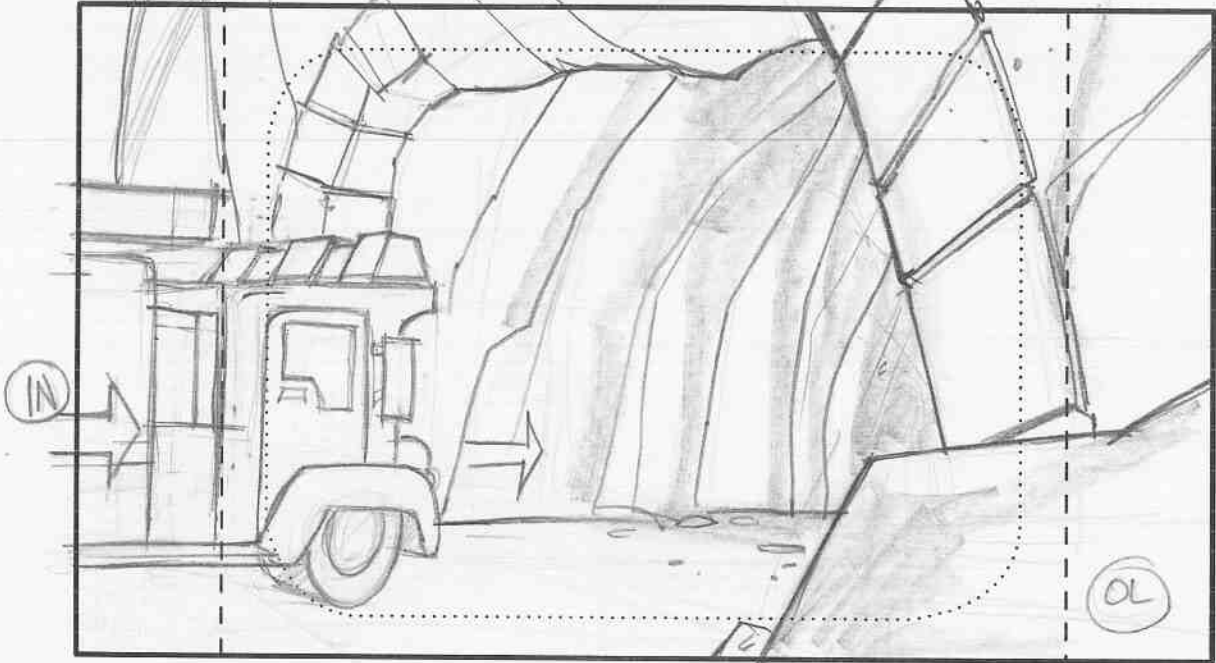

CUT **Action** ANGLE ON TUNNEL ENTRANCE - (CONTINUOUS)
RED CAUTIOUSLY APPROACHS THE ENTRANCE ...

Dialogue SFX: (ENGINE RUMBLE)

Sc. CONTD -

Panel B

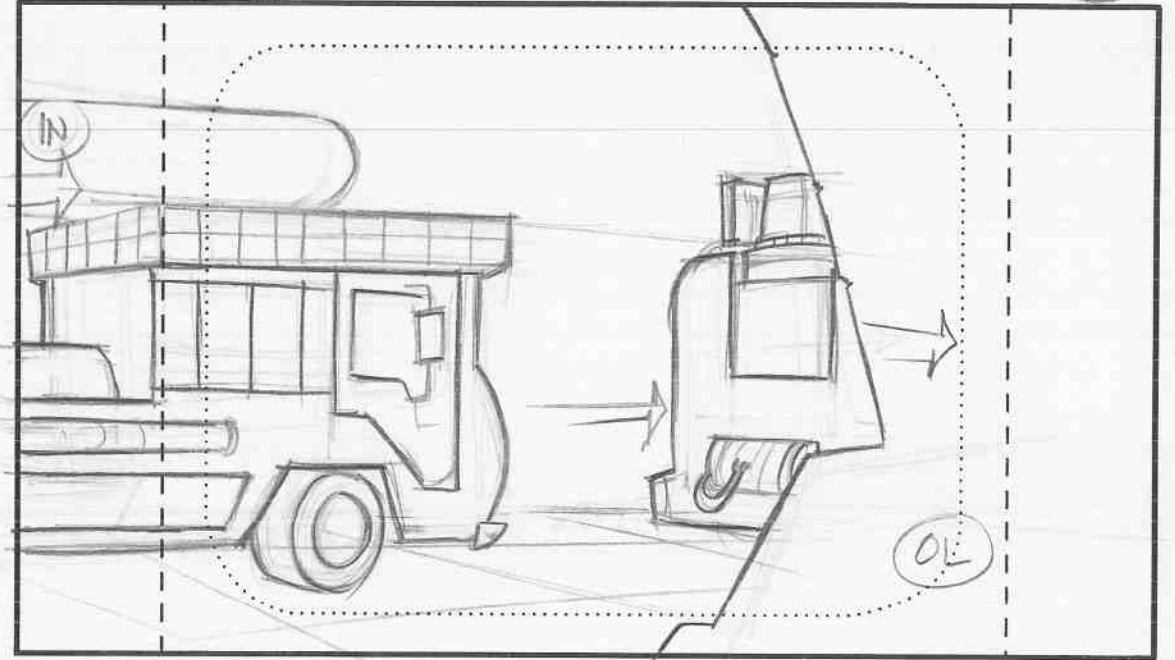

Action RED DRIVES INTO THE TUNNEL FOLLOWED BY PETROL.

CUT

Dialogue

257-777



FIREHOUSE TALES

©2005 Warner Bros. This Material is the PROPERTY OF WARNER BROS. TELEVISION ANIMATION. It is unpublished and must not be taken from the studio, duplicated or used in any manner, except for production purposes, and may not be sold or transferred.

Sc. 33

Panel

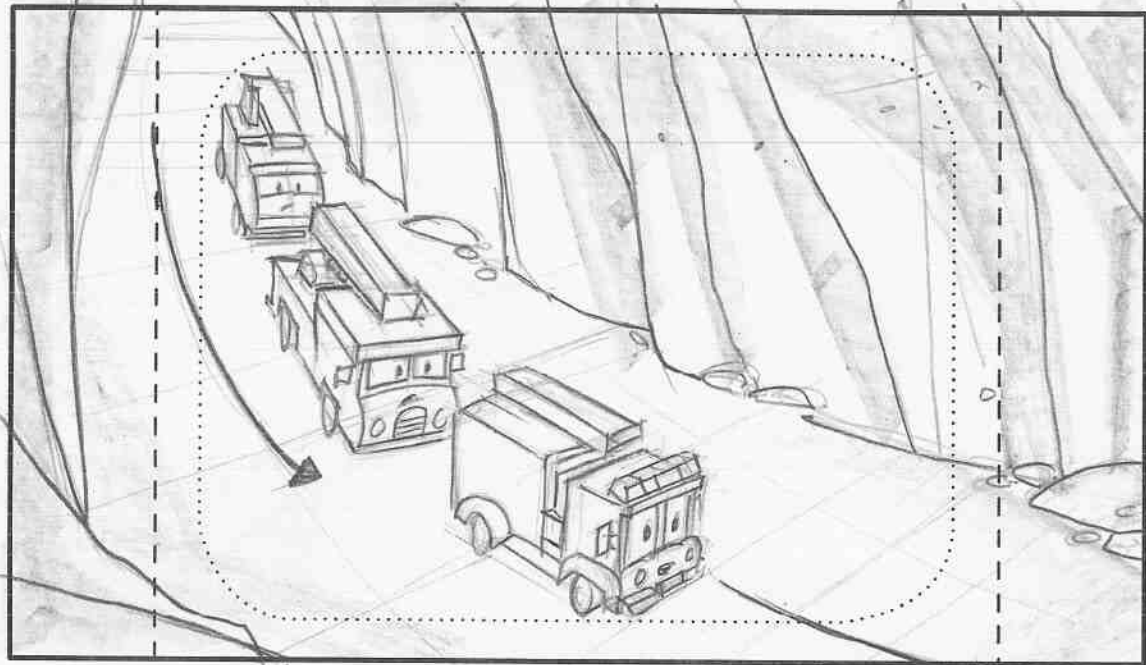

Dialogue Action
INT. TUNNEL
ANGLE ON TRUCKS CAUTIOUSLY DRIVING THROUGH. **OUT**

Dialogue (26) RED:
WE HAVE TO FIND OUT WHERE THE NOISE IS
COMING FROM.

Sc. 34

Panel

(A)

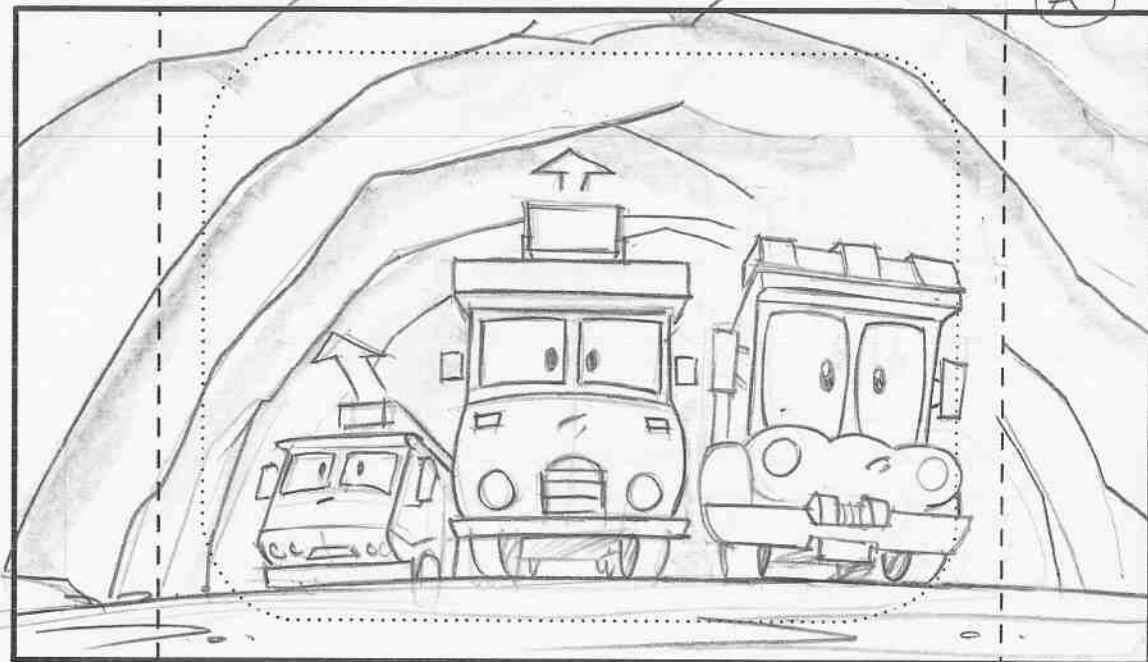

Dialogue Action
ANGLE ON RED. HE'S STOPPED. PETROL &
CRABBY PULL UP NEXT TO HIM. **CUT**

Dialogue

257-777



FIREHOUSE TALES

©2005 Warner Bros. This Material is the PROPERTY OF WARNER BROS. TELEVISION ANIMATION. It is unpublished and must not be taken from the studio, duplicated or used in any manner, except for production purposes, and may not be sold or transferred.

Sc. 3A CONTD

Panel (B)

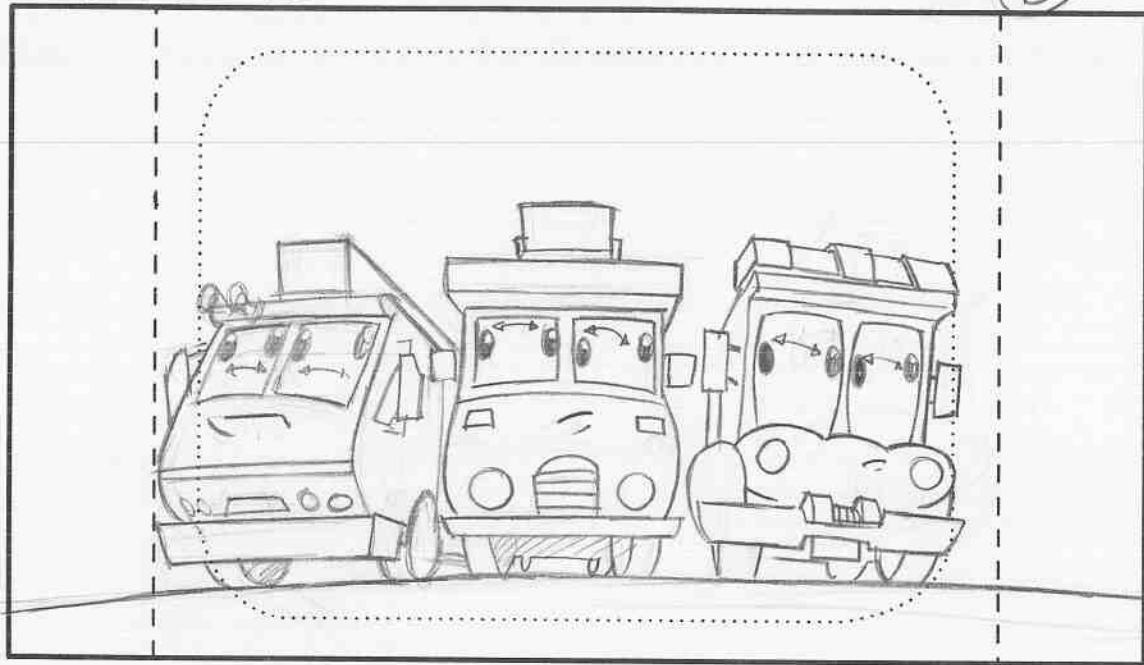

Dialogue Action THEY HUDDLE CLOSE TOGETHER, LOOKING FROM SIDE TO SIDE

Sc. CONTD

Panel (C)

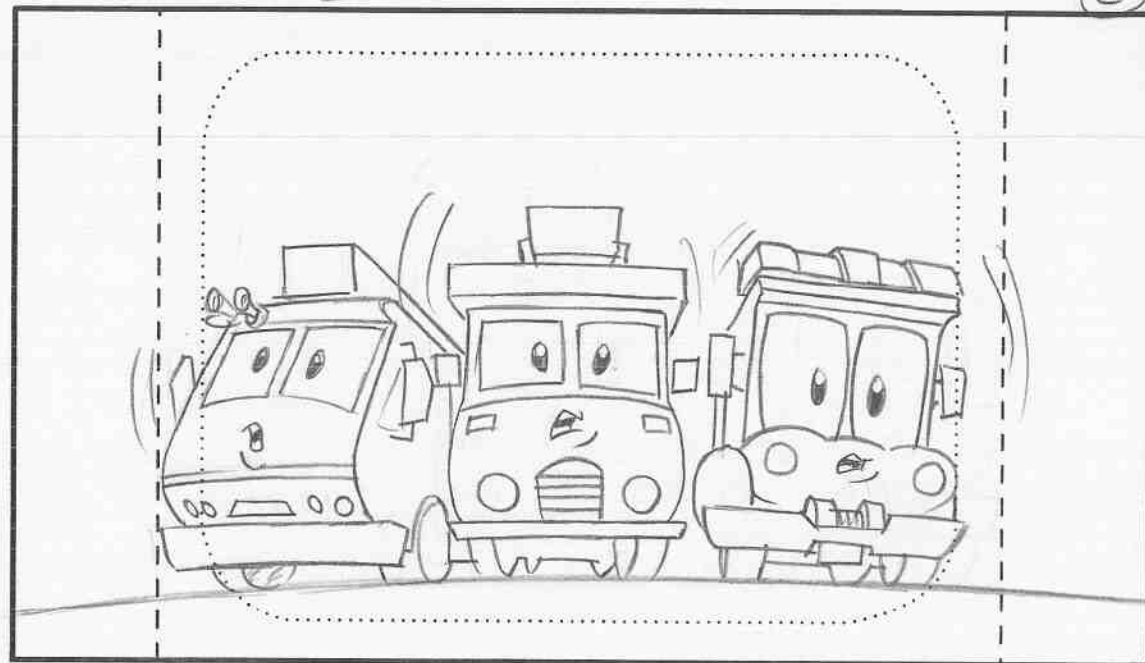

Dialogue Action SUDDENLY A RUMBLING NOISE STARTLES THEM.

SFX: < RUMBLING >

(27) RED/CRABBY/PETROL:

(WHOA!)

CUT

257-777



FIREHOUSE TALES

©2005 Warner Bros. This Material is the PROPERTY OF WARNER BROS. TELEVISION ANIMATION. It is unpublished and must not be taken from the studio, duplicated or used in any manner, except for production purposes, and may not be sold or transferred.

Sc. 35

S/A Bk 32 Panel

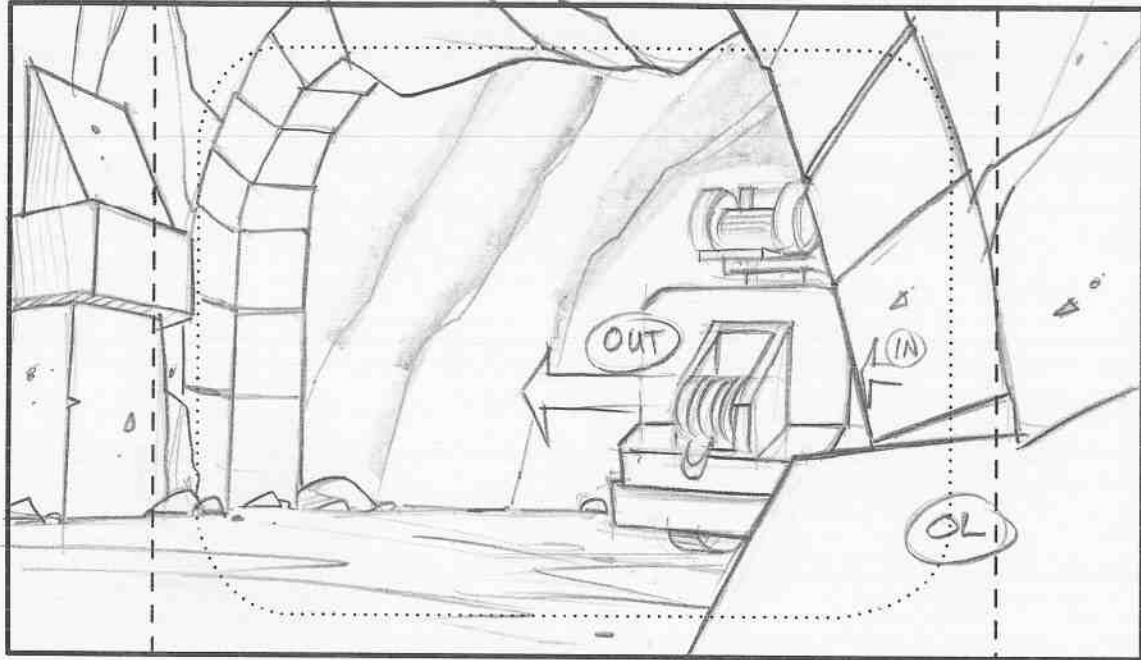

CUT Dialogue Action
EXT TUNNEL ENTRANCE -
CRABBY RUSHES OUT, (PAN W/ANIM (A) → (B))
HE'S SPEEDING BACKWARDS.

Dialogue Action

Sc.

Panel

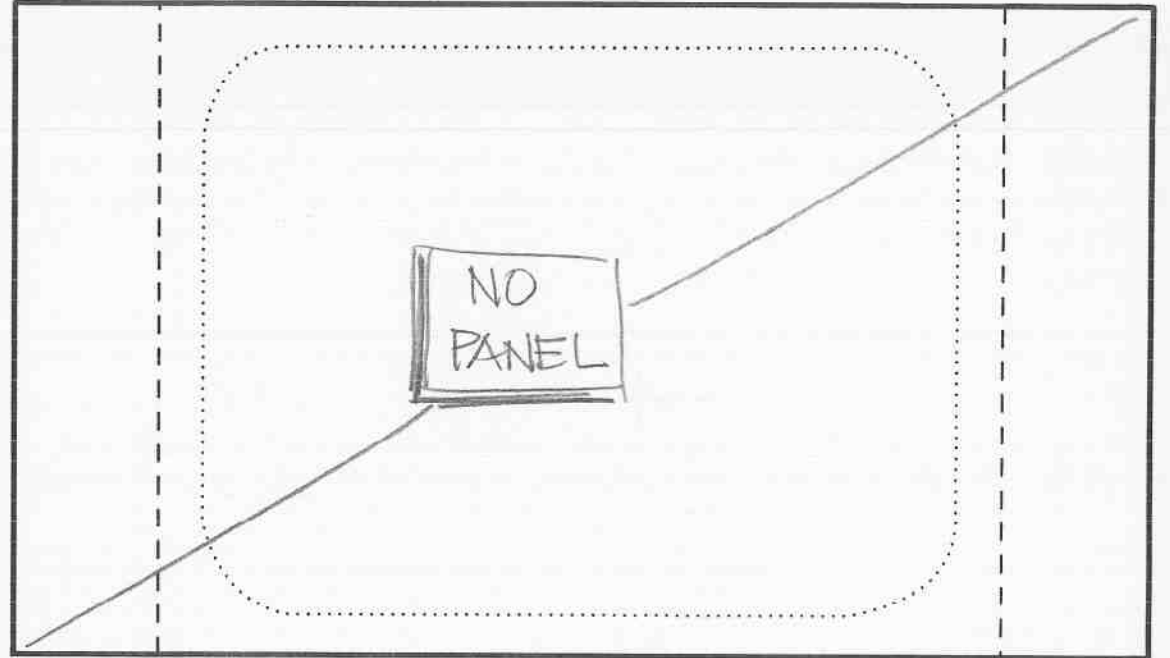

Dialogue Action

Dialogue Action

257-777



FIREHOUSE TALES

©2005 Warner Bros. This Material is the PROPERTY OF WARNER BROS. TELEVISION ANIMATION. It is unpublished and must not be taken from the studio, duplicated or used in any manner, except for production purposes, and may not be sold or transferred.

Sc. 35 CONTD.

Panel (B)

Sc.

Panel

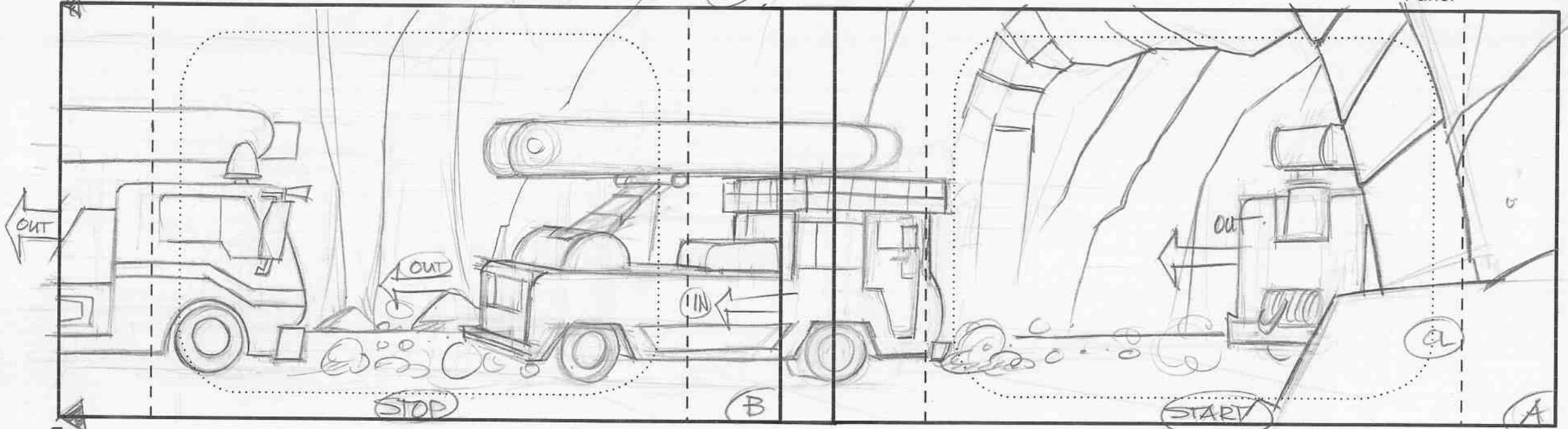

Dialogue Action

STOP PAN AS CRABBY EXITS. PETROL FOLLOWS THROUGH SCENE FOLLOWED BY RED.

Dialogue Action

EFF: (DX DUST)

CUT

257-777



FIREHOUSE TALES

©2005 Warner Bros. This Material is the PROPERTY OF WARNER BROS. TELEVISION ANIMATION. It is unpublished and must not be taken from the studio, duplicated or used in any manner, except for production purposes, and may not be sold or transferred.

Sc. 36

Panel A

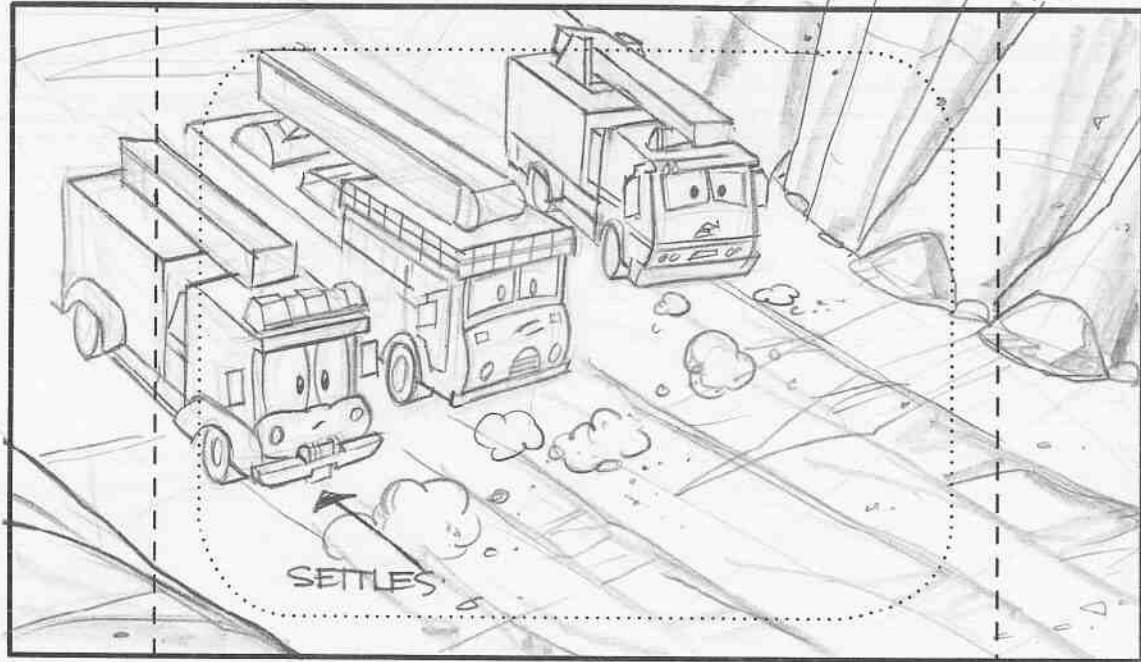

Sc.

CONTD.

Panel B

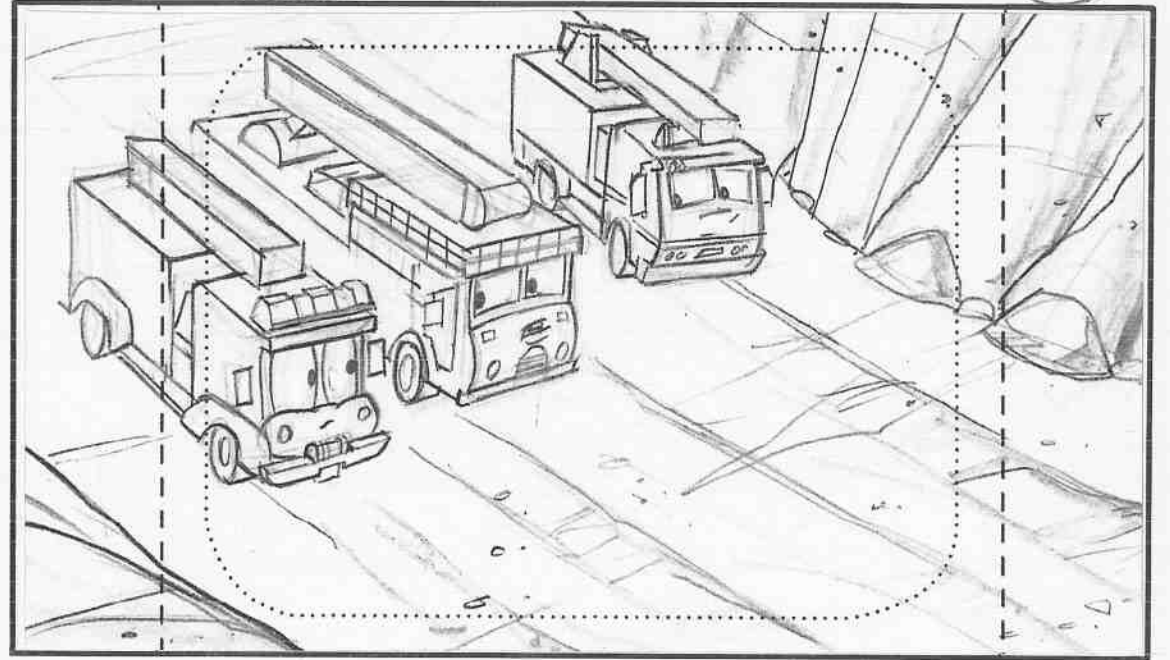

Action WIDE ON OUR GANG. RED SETTLES IN SCENE. THE DUST SETTLES.

EFX: CDX DUST.

Dialogue (28) CRABBY:
YEP. THAT'S WHERE IT'S COMING FROM.

SFX: <RUMBLING> ~~~~~> STOPS.

Action PETROL LOOKS OVER AT RED.

(29) PETROL:
CAN WE GO HOME NOW?

CUT

257-777



FIREHOUSE TALES

©2005 Warner Bros. This Material is the PROPERTY OF WARNER BROS. TELEVISION ANIMATION. It is unpublished and must not be taken from the studio, duplicated or used in any manner, except for production purposes, and may not be sold or transferred.

Sc. 37

Panel

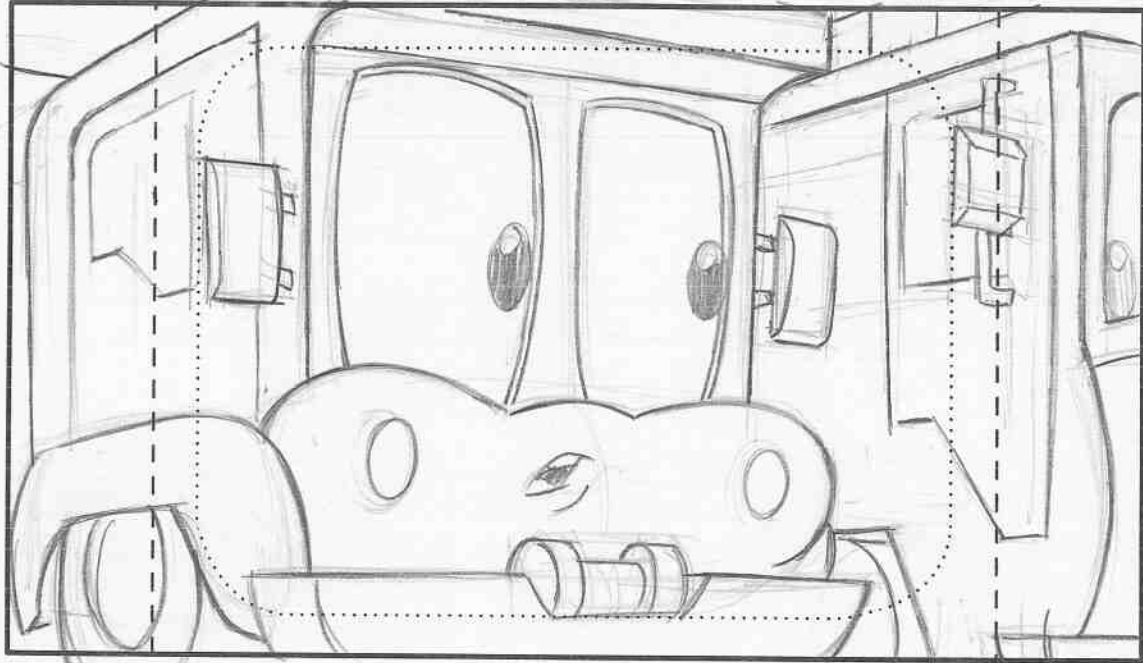

CLOSE ON RED

PETROL

CUT
Dialogue Action

(30) RED:

AND LOSE ANOTHER NIGHT'S SLEEP?

Sc.

CONTD

Panel (B)

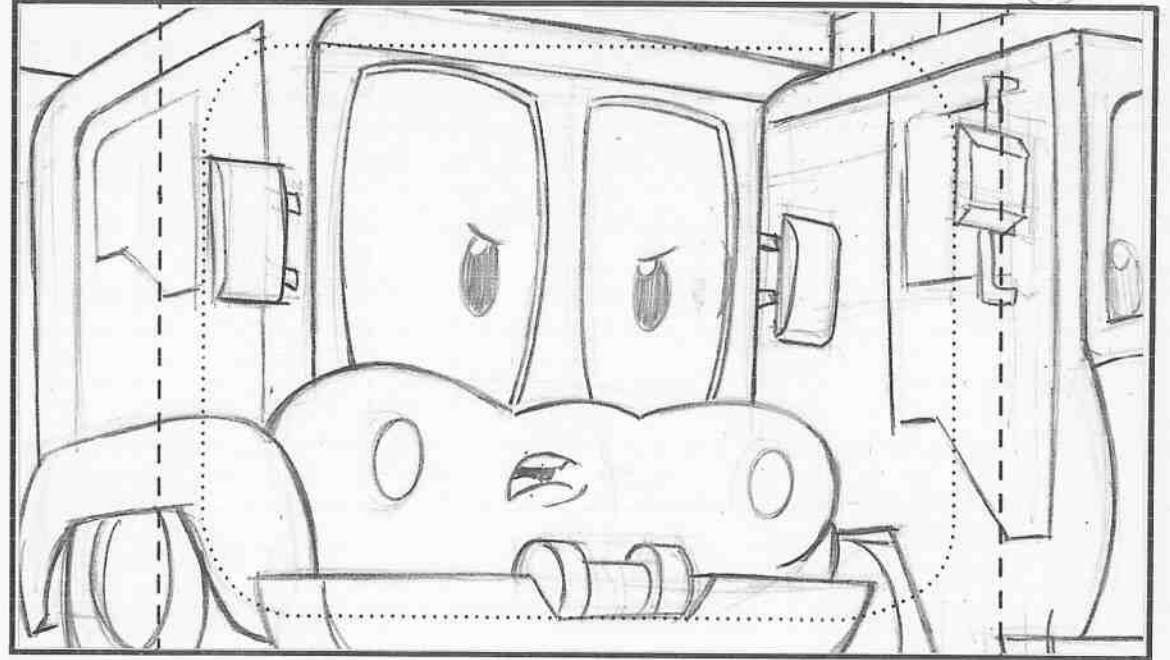

RED LOOKS BACK AT THE O.S. TUNNEL

Dialogue Action

(30) RED: (CONTD).

NO WAY!



FIREHOUSE TALES

©2005 Warner Bros. This Material is the PROPERTY OF WARNER BROS. TELEVISION ANIMATION. It is unpublished and must not be taken from the studio, duplicated or used in any manner, except for production purposes, and may not be sold or transferred.

Sc. 37 CONTD.

Panel C

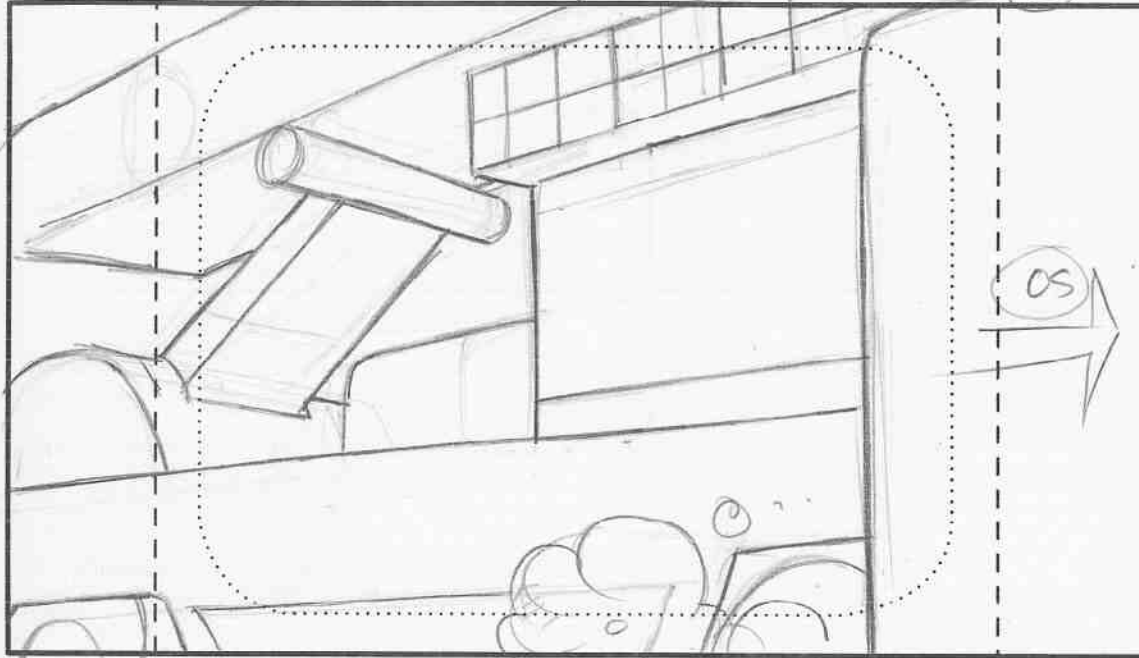

Dialogue Action

RED EXITS SCENE

EFX: (DX DUST

(30) RED: (CONTD)

COME ON!

CUT

Sc.

Panel

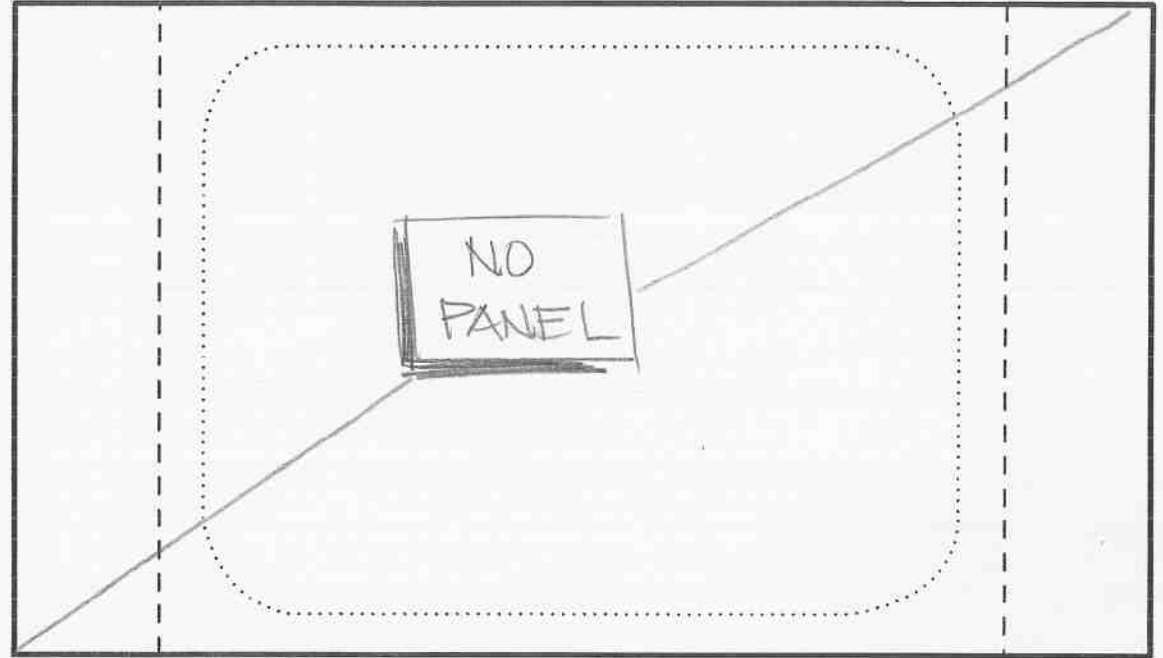

Dialogue Action



FIREHOUSE TALES

©2005 Warner Bros. This Material is the PROPERTY OF WARNER BROS. TELEVISION ANIMATION. It is unpublished and must not be taken from the studio, duplicated or used in any manner, except for production purposes, and may not be sold or transferred.

Sc. 38

S/ABG 32 Panel (A)

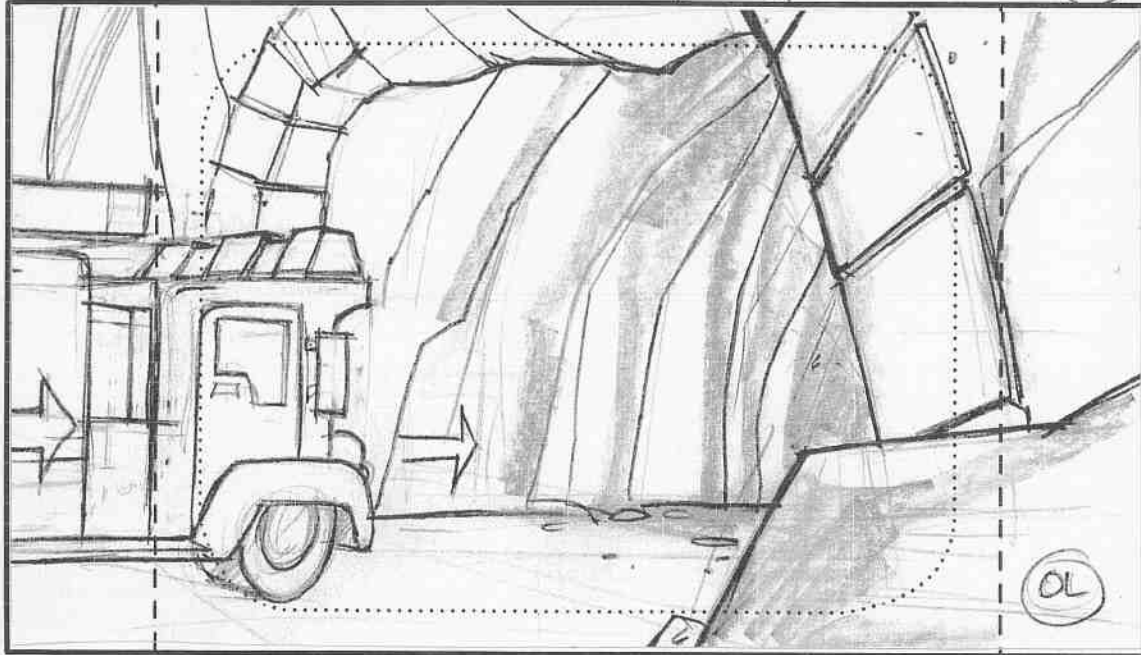

RED (Z)

CUT

Dialogue Action

EXT TUNNEL. —
RED DRIVES CAUTIOUSLY TOWARDS THE TUNNEL ENTRANCE.

Sc. CONTD -

Panel (B)

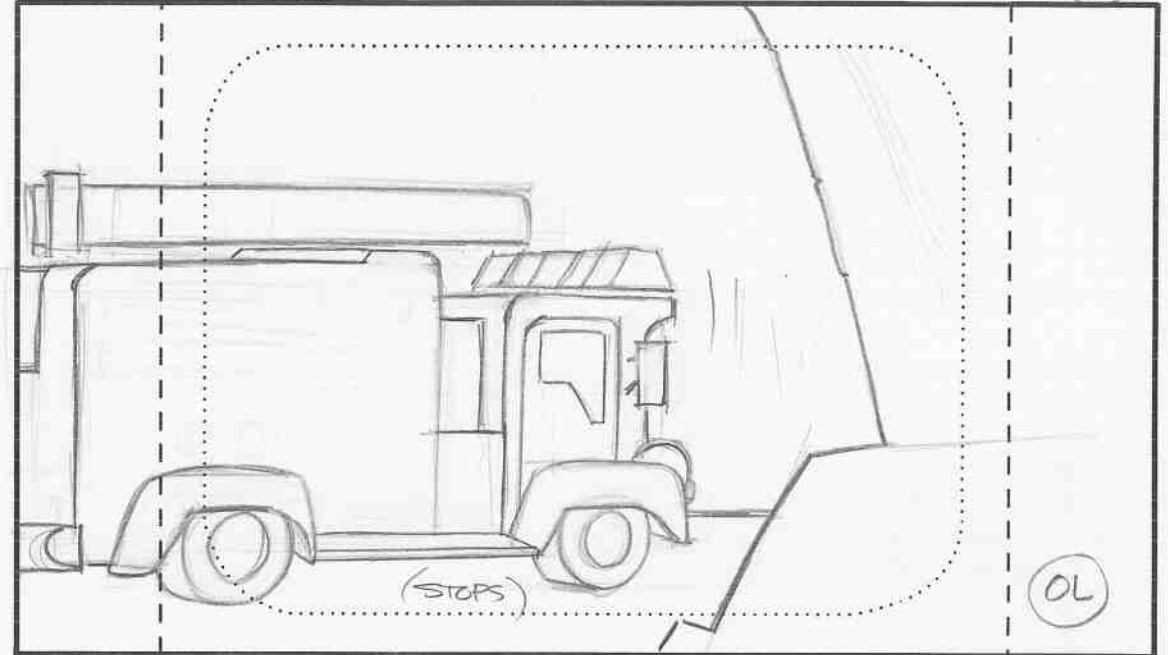

(STOPS)

Dialogue Action

SUDDENLY RED STOPS. A BIG MOTOR SOUND COMES FROM INSIDE THE TUNNEL.

SFX: <RUMBLING> ~~~~~>



FIREHOUSE TALES

©2005 Warner Bros. This Material is the PROPERTY OF WARNER BROS. TELEVISION ANIMATION. It is unpublished and must not be taken from the studio, duplicated or used in any manner, except for production purposes, and may not be sold or transferred.

Sc. 38

CONT'D.

Panel

(C)

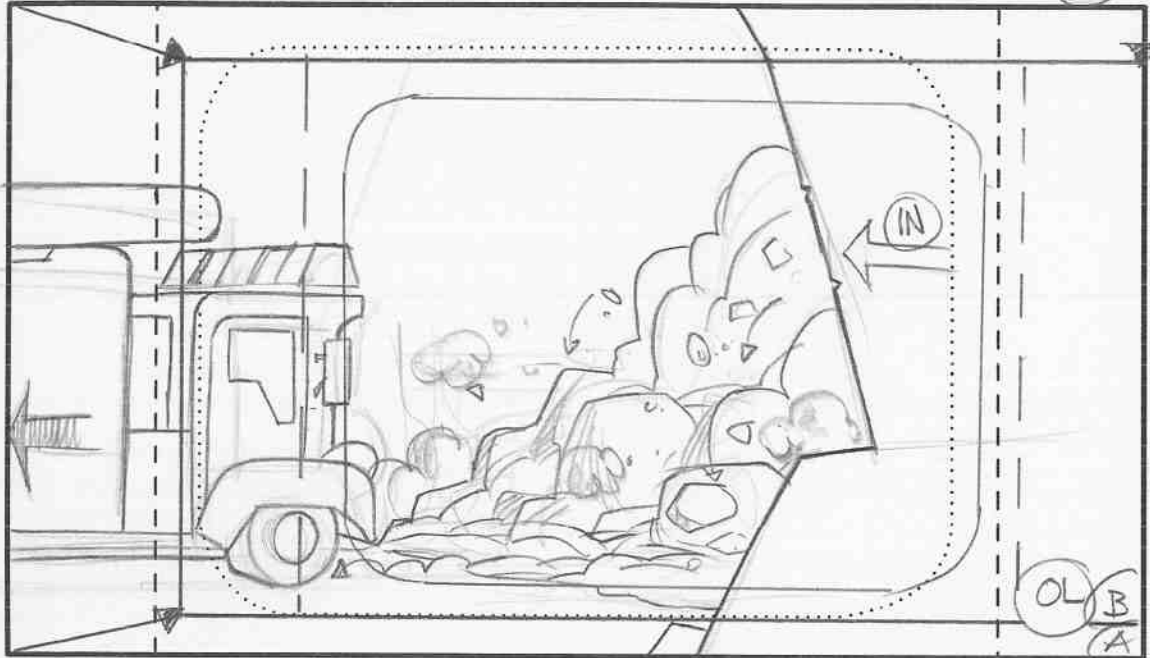

Dialogue Action

RED BACKS OUT QUICKLY AS A WALL OF DIRT RUMBLES OUT OF THE TUNNEL. TRUCK IN (A) → (B)

(31) RED:

(WHOA!)

SFX: <BIG MOTOR> EFX: (DX DUST)

Sc.

CONT'D.

Panel

(D)

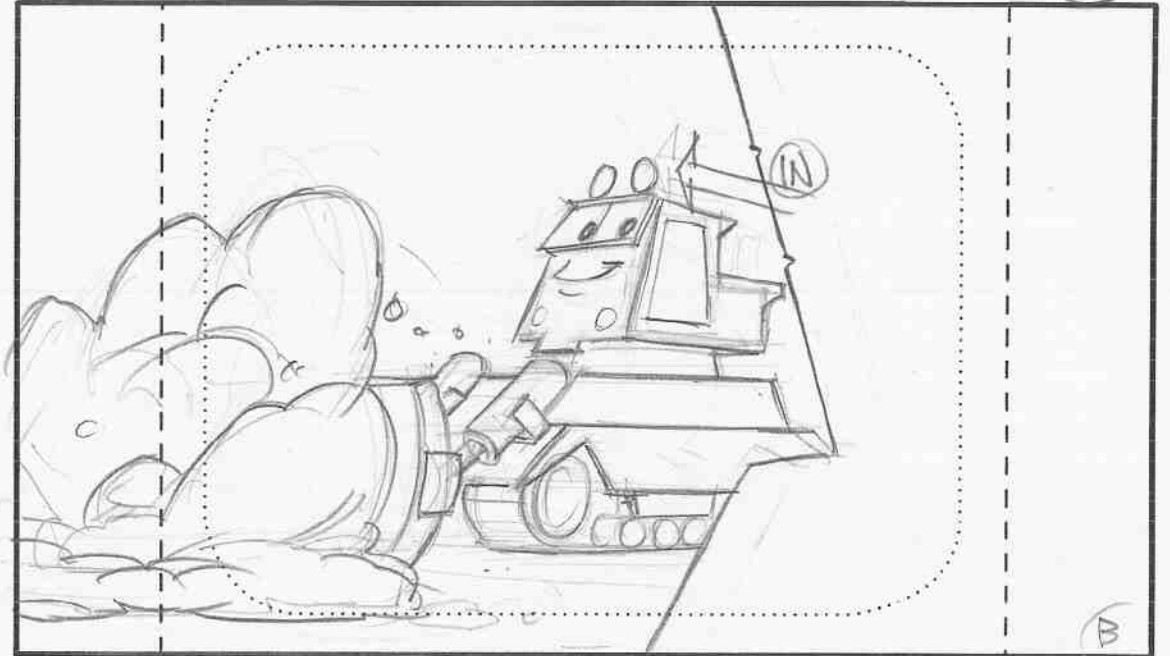

Dialogue Action

BUBBA RUMBLES INTO SCENE.



FIREHOUSE TALES

©2005 Warner Bros. This Material is the PROPERTY OF WARNER BROS. TELEVISION ANIMATION. It is unpublished and must not be taken from the studio, duplicated or used in any manner, except for production purposes, and may not be sold or transferred.

Sc. 39

Panel

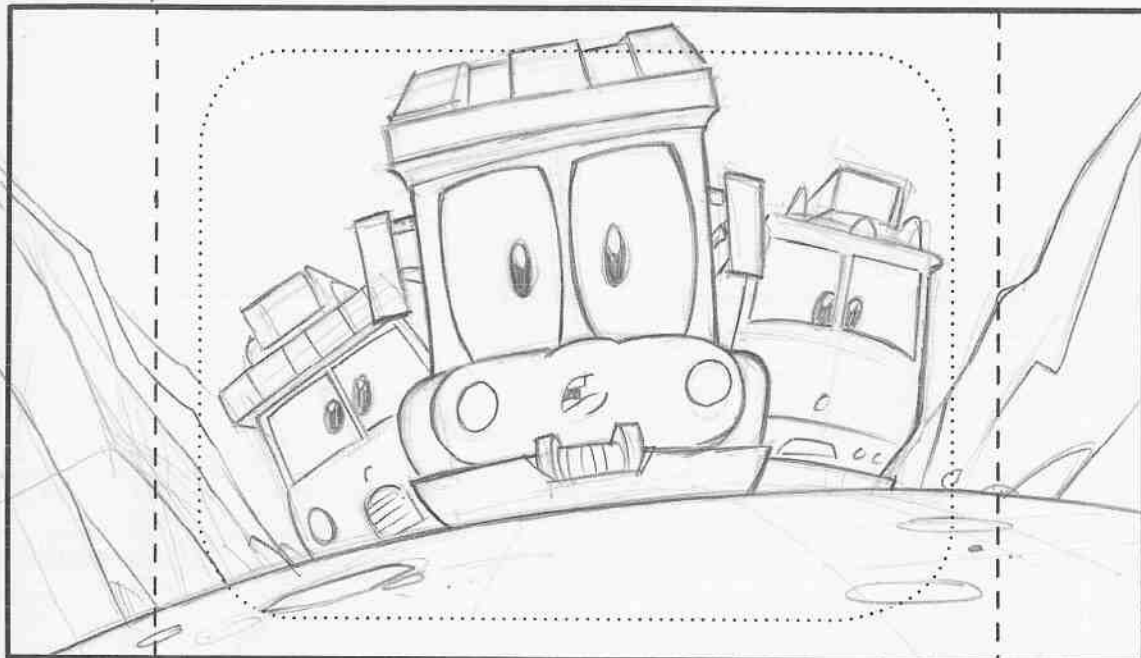

CUT
Action ANGLE ON RED. PETROL AND CRABBY PEEK OUT FROM BEHIND HIM

Dialogue (32) RED : (EXCITED & RELIEVED)
BUBBA ? WHAT'RE YOU DOING HERE ?

Sc. 40

Panel (A)

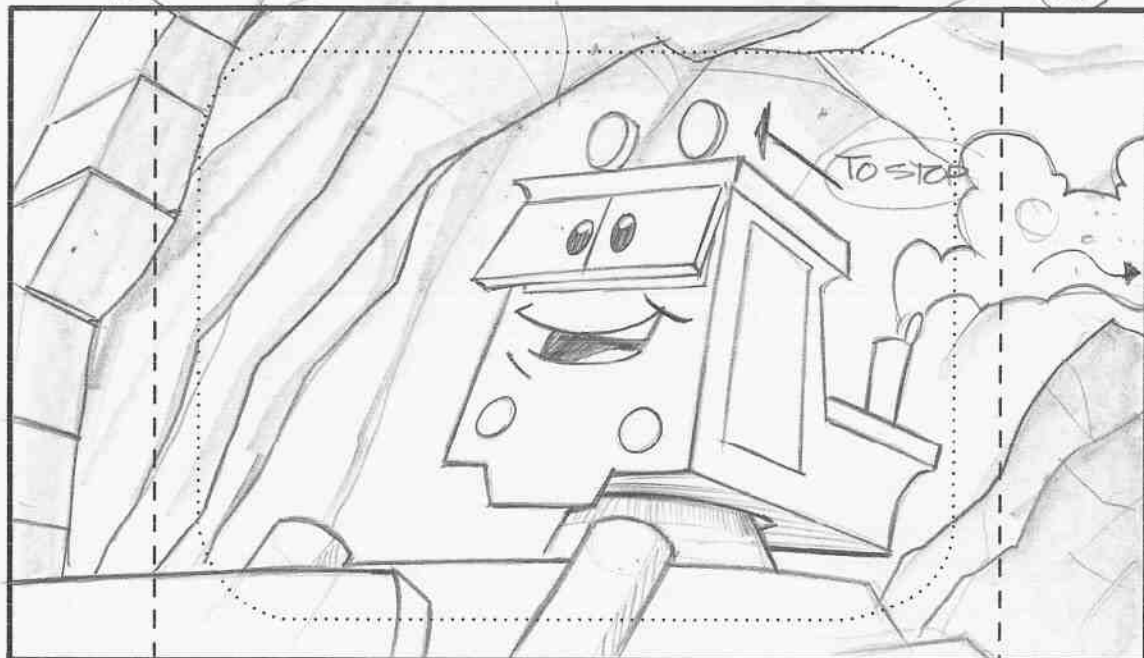

CUT
Action CLOSE ON BUBBA HE ROLLS TO A STOP

EFX: (DX EXHAUST)
(33) BUBBA :
HEY GUYS ! I'M HELPING OUT WITH THE NEW SUBWAY THAT'S BEING BUILT.



FIREHOUSE TALES

©2005 Warner Bros. This Material is the PROPERTY OF WARNER BROS. TELEVISION ANIMATION. It is unpublished and must not be taken from the studio, duplicated or used in any manner, except for production purposes, and may not be sold or transferred.

Sc. 40 CONTD

Panel (B)

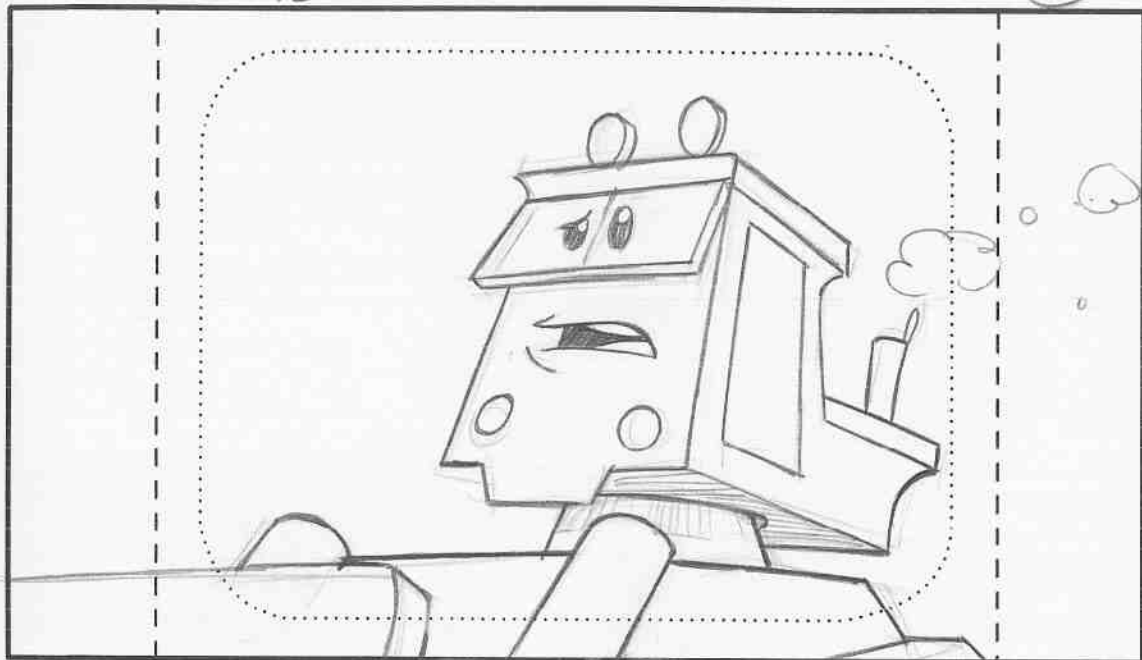

Dialogue Action

BUBBA IS CURIOUS.

(33) BUBBA: (CURIOUS)

WHAT'RE YOU DOING HERE?

CUT

Sc.

Panel

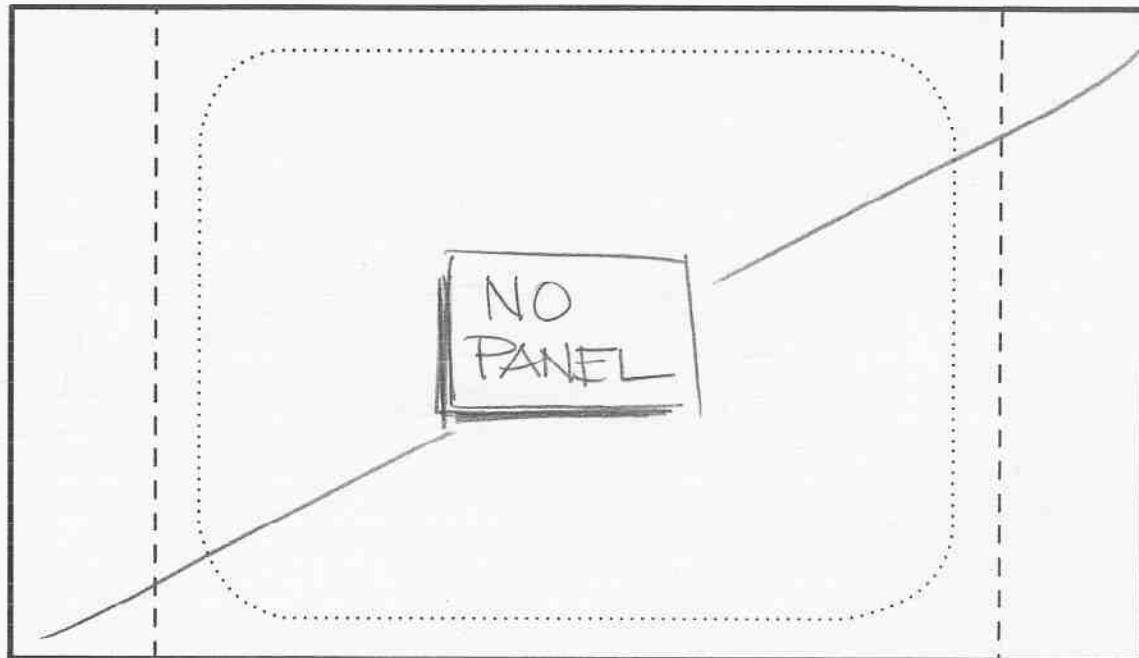

Dialogue Action

257-777



FIREHOUSE TALES

©2005 Warner Bros. This Material is the PROPERTY OF WARNER BROS. TELEVISION ANIMATION. It is unpublished and must not be taken from the studio, duplicated or used in any manner, except for production purposes, and may not be sold or transferred.

Sc. 41

Panel

Sc.

Panel

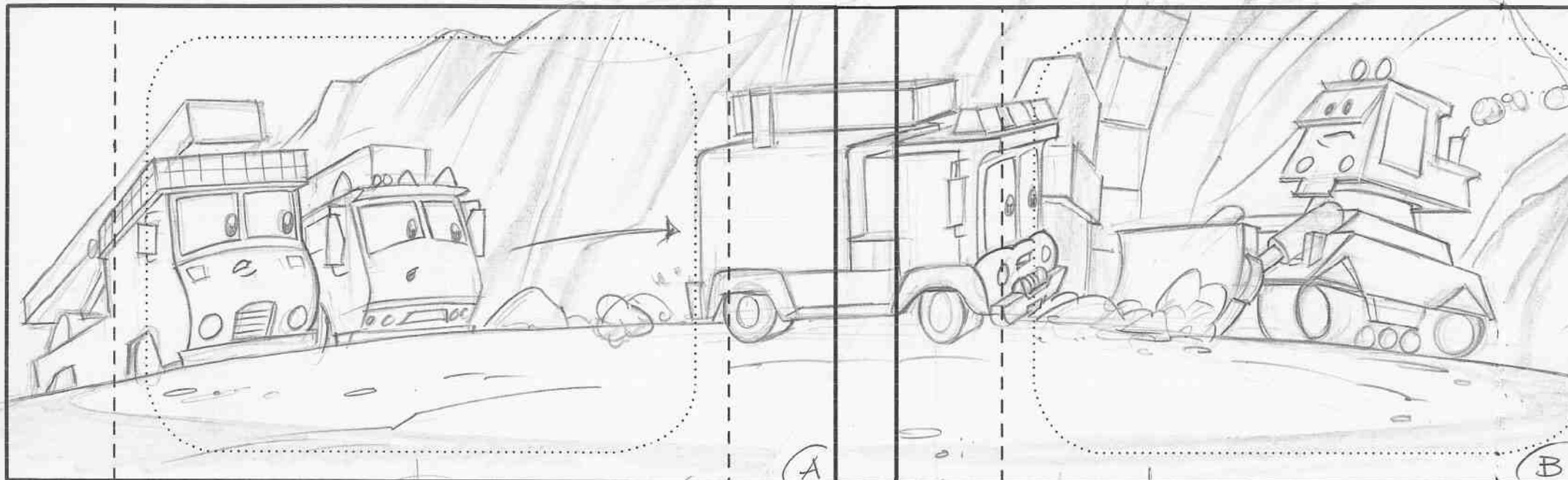

(START) ————— (PAN W/ANIM) ————— (STOP)

CUT

Action WIDE ON FIRETRUCKS, RED DRIVES FORWARD, (PAN W/ANIM (A) → (B)), AND STOPS IN FRONT OF BUBBA.

EFFX: (DX EXHAUST & DUST)

CUT

Dialogue (34) RED:
THERE'S A TERRIBLE NOISE COMING FROM THE TUNNEL. IT'S BEEN KEEPING US AWAKE ALL NIGHT.

Dialogue

257-777



FIREHOUSE TALES

©2005 Warner Bros. This Material is the PROPERTY OF WARNER BROS. TELEVISION ANIMATION. It is unpublished and must not be taken from the studio, duplicated or used in any manner, except for production purposes, and may not be sold or transferred.

Sc. 42

S/ABG 40 Panel (A)

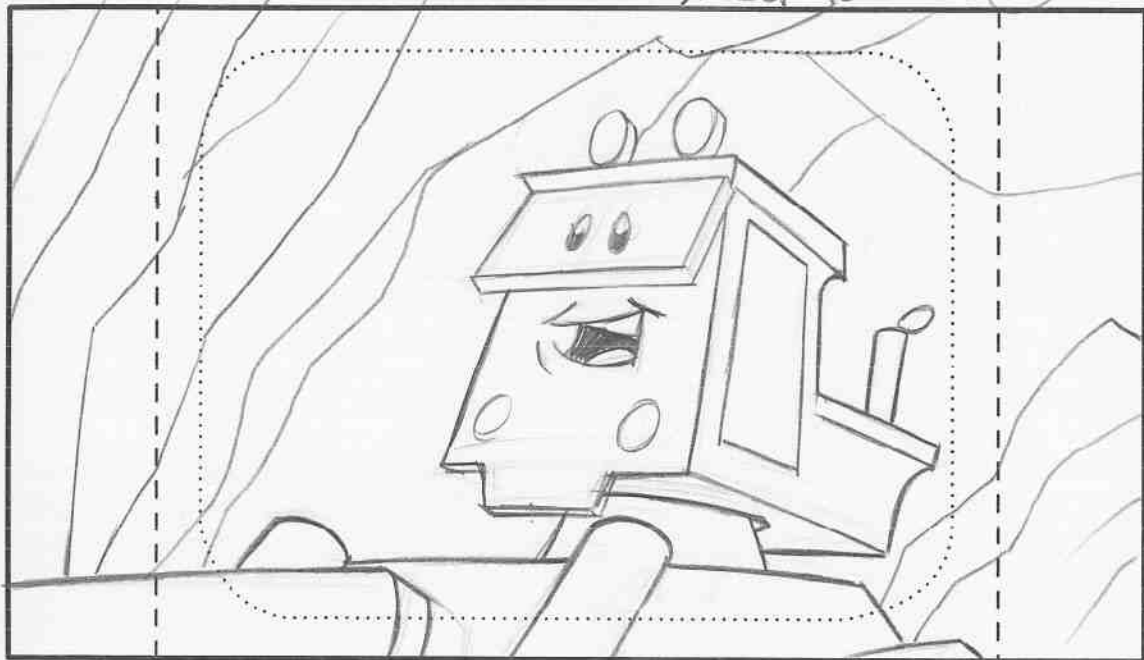

CUT

Dialogue Action

ANGLE ON BUBBA

(35) BUBBA:

OH, I BET THAT'S NOSEY. HE'S THE DIGGER ON THIS JOB.

Sc. CONTD -

Panel (B)

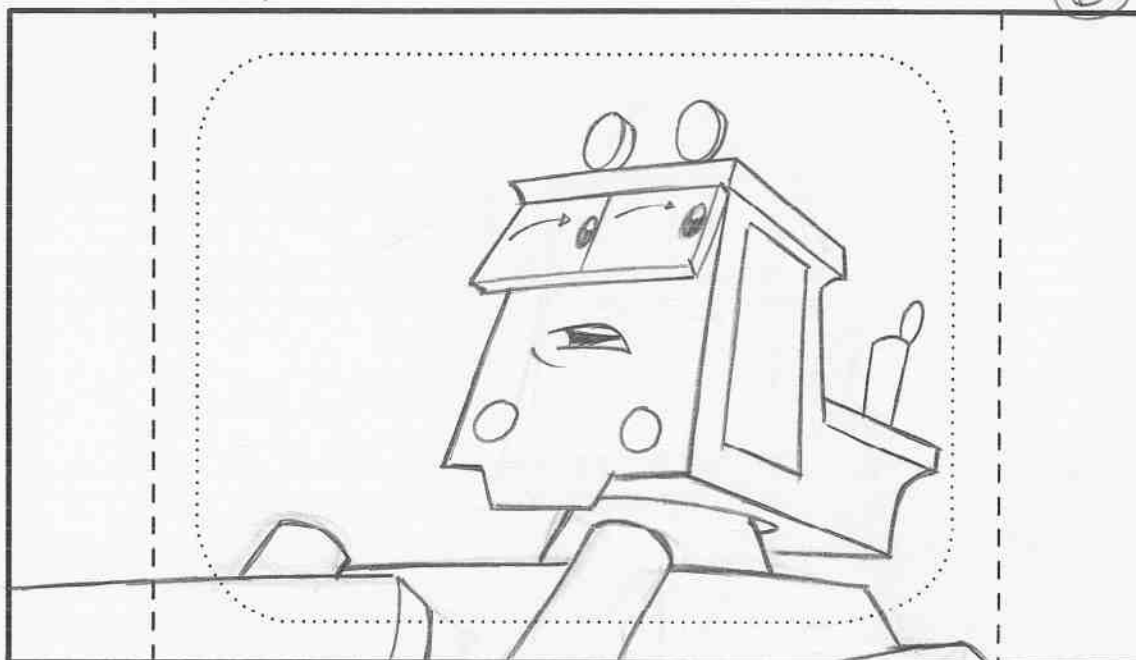

CUT

Dialogue Action

BUBBA LOOKS OVER HIS SHOULDER

(35) BUBBA: (CONTD)

HE'S BEEN PRETTY CRANKY LATELY!

257-777



FIREHOUSE TALES

©2005 Warner Bros. This Material is the PROPERTY OF WARNER BROS. TELEVISION ANIMATION. It is unpublished and must not be taken from the studio, duplicated or used in any manner, except for production purposes, and may not be sold or transferred.

Sc. 43

Panel

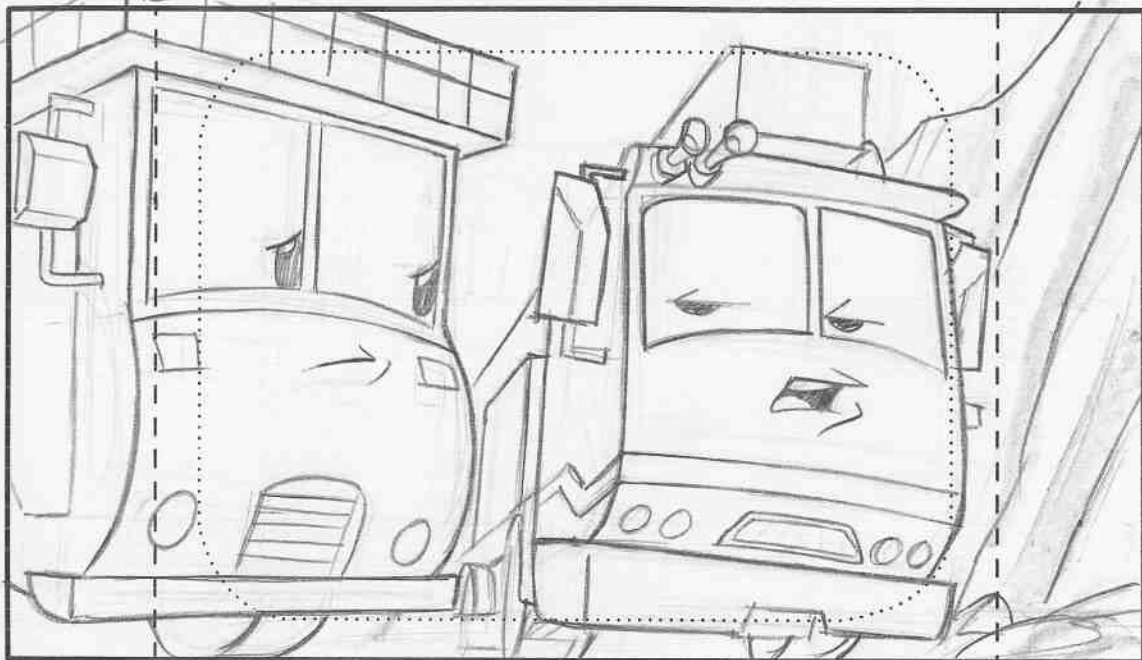

CUT

Dialogue Action

CLOSE ON CRABBY & PETROL
THEY LOOK AT EACH OTHER.

36 CRABBY:

I KNOW THE FEELING.

Sc. 44

SABG 4 Panel



CUT

Dialogue Action

ANGLE ON RED & DUBBA

37 RED:

WHY'S HE SO CRANKY?

257-777



FIREHOUSE TALES

©2005 Warner Bros. This Material is the PROPERTY OF WARNER BROS. TELEVISION ANIMATION. It is unpublished and must not be taken from the studio, duplicated or used in any manner, except for production purposes, and may not be sold or transferred.

Sc. 44 CONTD

Panel (B)

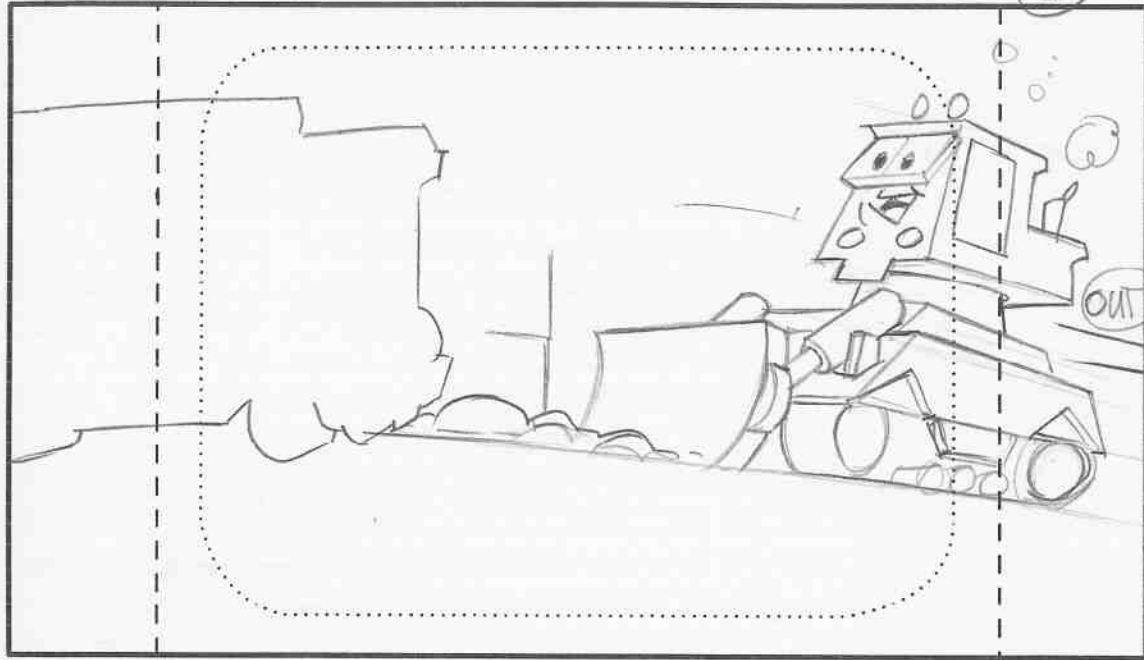

Dialogue Action

BUBBA BACKS OUT-

EFX: (DX EXHAUST)

(38) BUBBA:

I'll show you, c'mon!

SFX: <MOTOR NOISE>

CUT

Sc. 45

Panel (A)

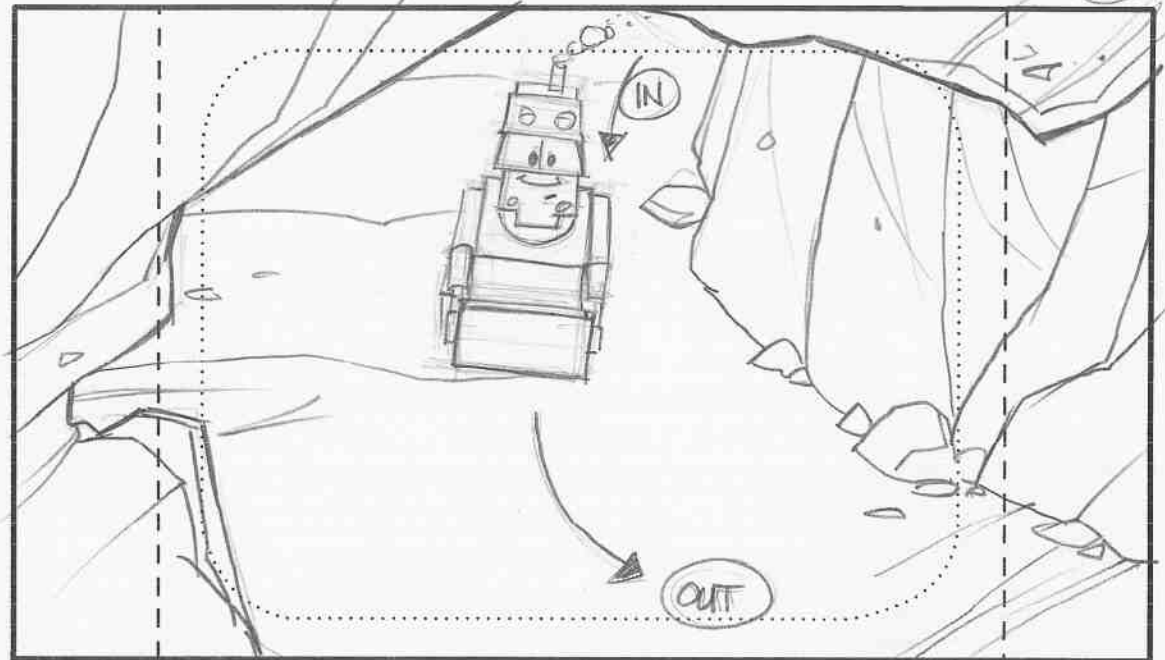

Dialogue Action

INT. TUNNEL. -

BUBBA ROUNDS THE CORNER AND CHUGS PAST CAMERA.

EFX: (DX EXHAUST)

SFX: <MOTOR NOISE>

257-777



FIREHOUSE TALES

©2005 Warner Bros. This Material is the PROPERTY OF WARNER BROS. TELEVISION ANIMATION. It is unpublished and must not be taken from the studio, duplicated or used in any manner, except for production purposes, and may not be sold or transferred.

Sc. 45 CONTD.

Panel B

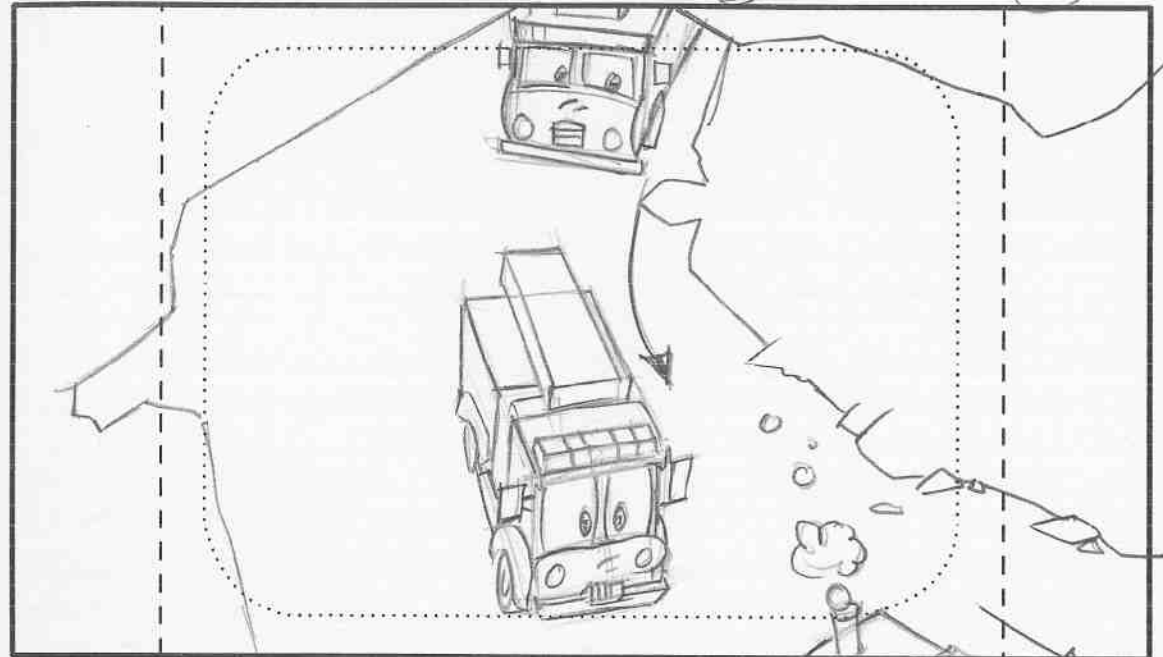

Dialogue Action

BUBBA IS FOLLOWED BY RED, WHO IS FOLLOWED BY PETROL.

BUBBA OUT

SFX: <MOTOR NOISE>

Sc.

Panel

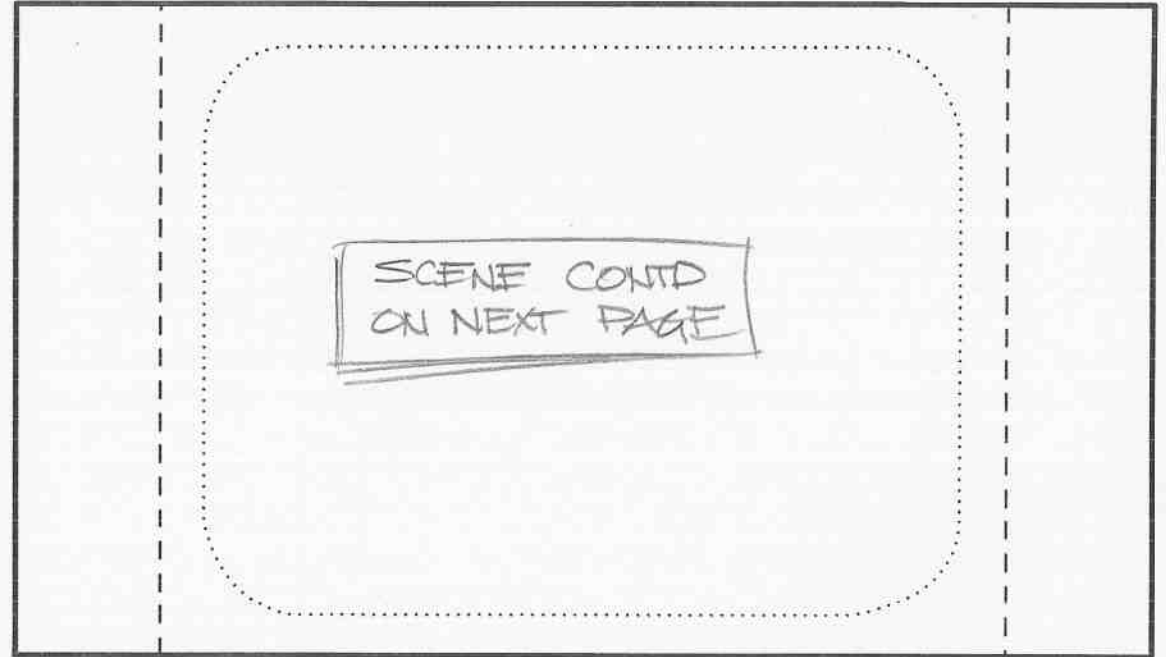

Dialogue Action



FIREHOUSE TALES

©2005 Warner Bros. This Material is the PROPERTY OF WARNER BROS. TELEVISION ANIMATION. It is unpublished and must not be taken from the studio, duplicated or used in any manner, except for production purposes, and may not be sold or transferred.

Sc. 45 CONTD

Panel (C)



Dialogue Action

PETROL IS FOLLOWED BY
CRABBY. PAN & TRUCK OUT
(A) → (B)

CUT

257-777



FIREHOUSE TALES

©2005 Warner Bros. This Material is the PROPERTY OF WARNER BROS. TELEVISION ANIMATION. It is unpublished and must not be taken from the studio, duplicated or used in any manner, except for production purposes, and may not be sold or transferred.

Sc. 46

Panel

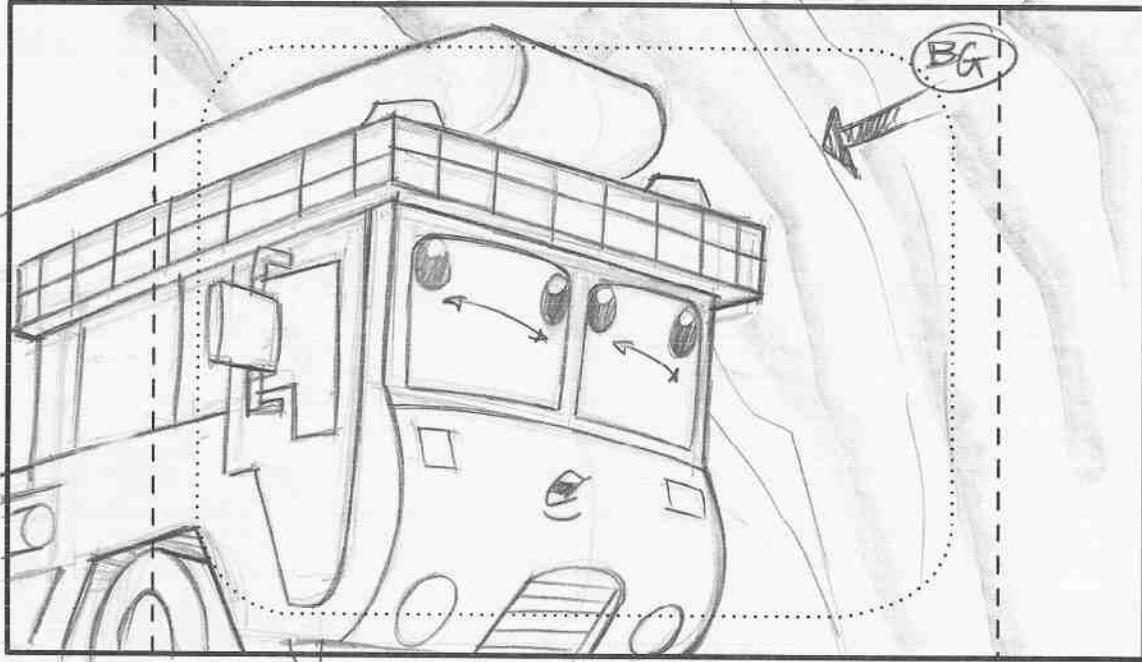

CUT

Dialogue Action

CLOSE ON PETROL LOOKING AROUND.

PAN BG

CUT

(39) PETROL:

GOODNESS GRACIOUS, IT SURE IS BIG IN HERE.

Sc. 47

Panel

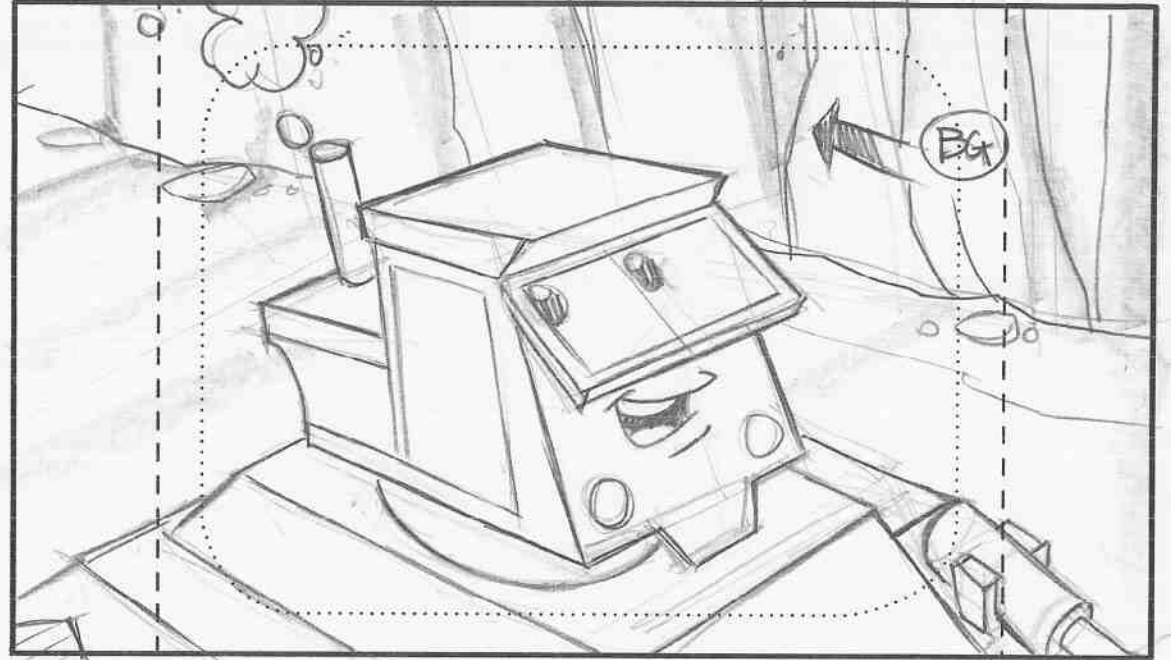

Dialogue Action

ANGLE ON BUBBA HE LOOKS BACK OVER HIS

'SHOULDER'

(PAN BG)

(40) BUBBA:

YOU HAVEN'T SEEN BIG YET!



FIREHOUSE TALES

©2005 Warner Bros. This Material is the PROPERTY OF WARNER BROS. TELEVISION ANIMATION. It is unpublished and must not be taken from the studio, duplicated or used in any manner, except for production purposes, and may not be sold or transferred.

Sc.

Panel

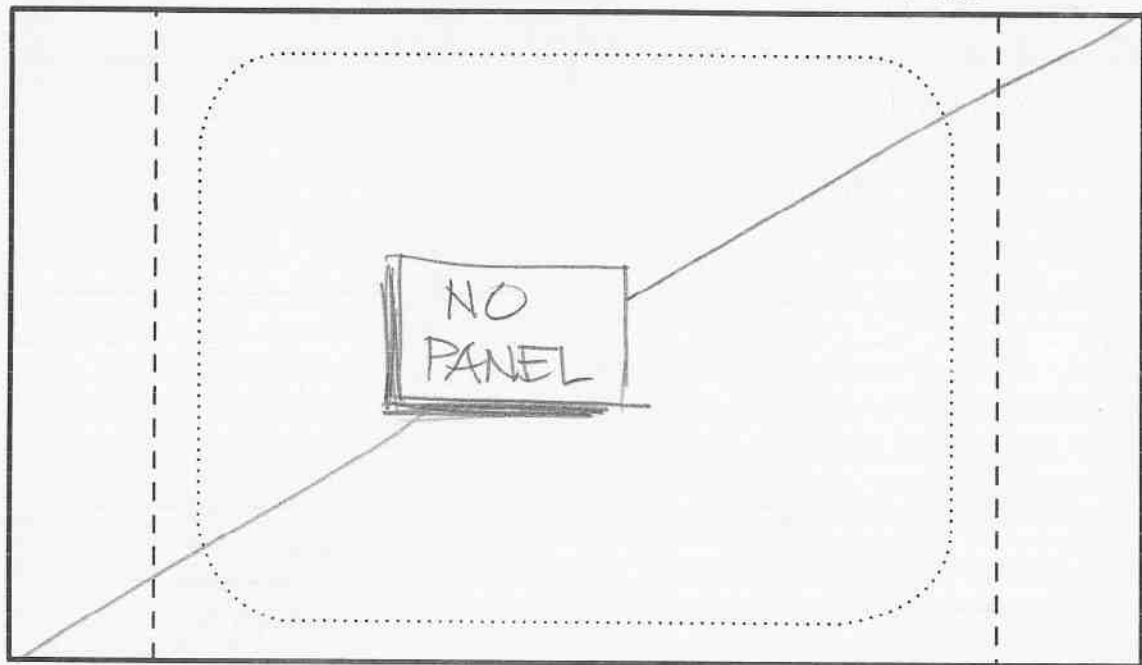

Dialogue Action

Three horizontal lines for dialogue and action notes.

Sc. 48

Panel

(A)



Dialogue Action

INT. MAIN TUNNEL CHAMBER -
BUBBA ENTERS FROM THE TUNNEL..

Three horizontal lines for dialogue and action notes.

257-777



FIREHOUSE TALES

©2005 Warner Bros. This Material is the PROPERTY OF WARNER BROS. TELEVISION ANIMATION. It is unpublished and must not be taken from the studio, duplicated or used in any manner, except for production purposes, and may not be sold or transferred.

Sc. 48 CONTD.

Panel (B)

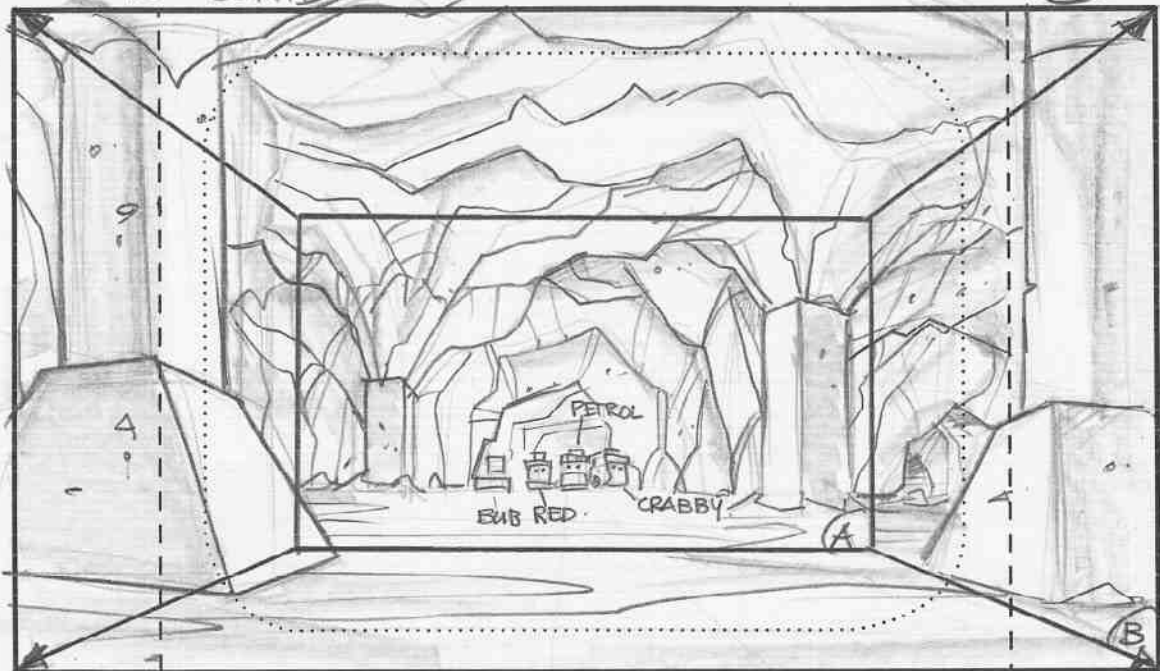

Dialogue Action TRUCK OUT (A) → (B) AS BUBBA COMES TO A STOP FOLLOWED BY RED, PETROL & CRABBY.

(CUT)

Dialogue (40A) RED/PETROL/CRABBY:
<AWE!>

Sc. 49

Panel

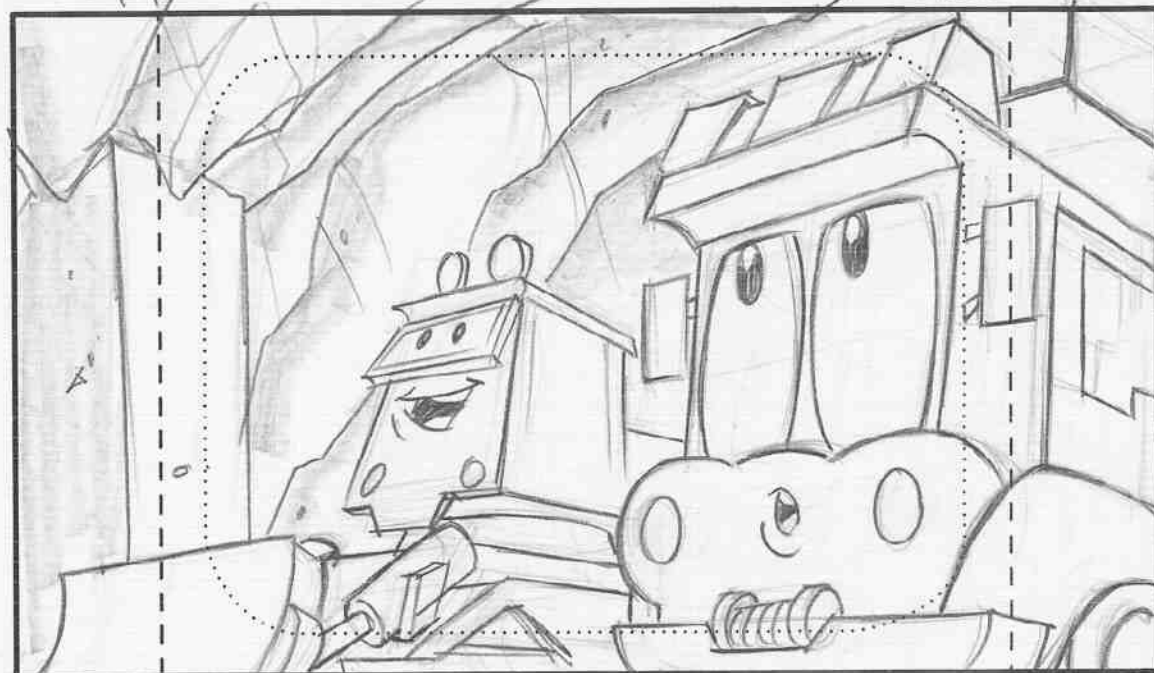

Dialogue Action ANGLE ON BUBBA & RED.

Dialogue (A) BUBBA:
THIS IS WHERE THE SUBWAY STATION...

257-777



FIREHOUSE TALES

©2005 Warner Bros. This Material is the PROPERTY OF WARNER BROS. TELEVISION ANIMATION. It is unpublished and must not be taken from the studio, duplicated or used in any manner, except for production purposes, and may not be sold or transferred.

Sc. 49 - CONTD

Panel B

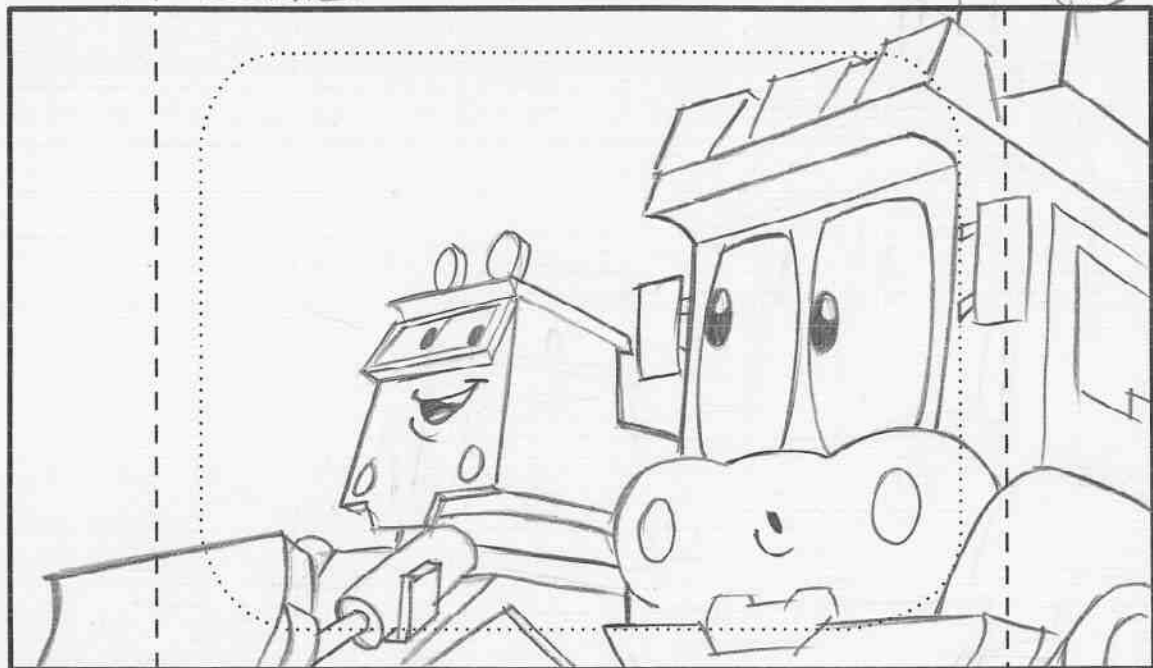

BUBBA LOOKS OVER AT RED.

Dialogue Action

41) BUBBA: (CONTD)

.. IS GOING TO BE!

Sc. CONTD

Panel C

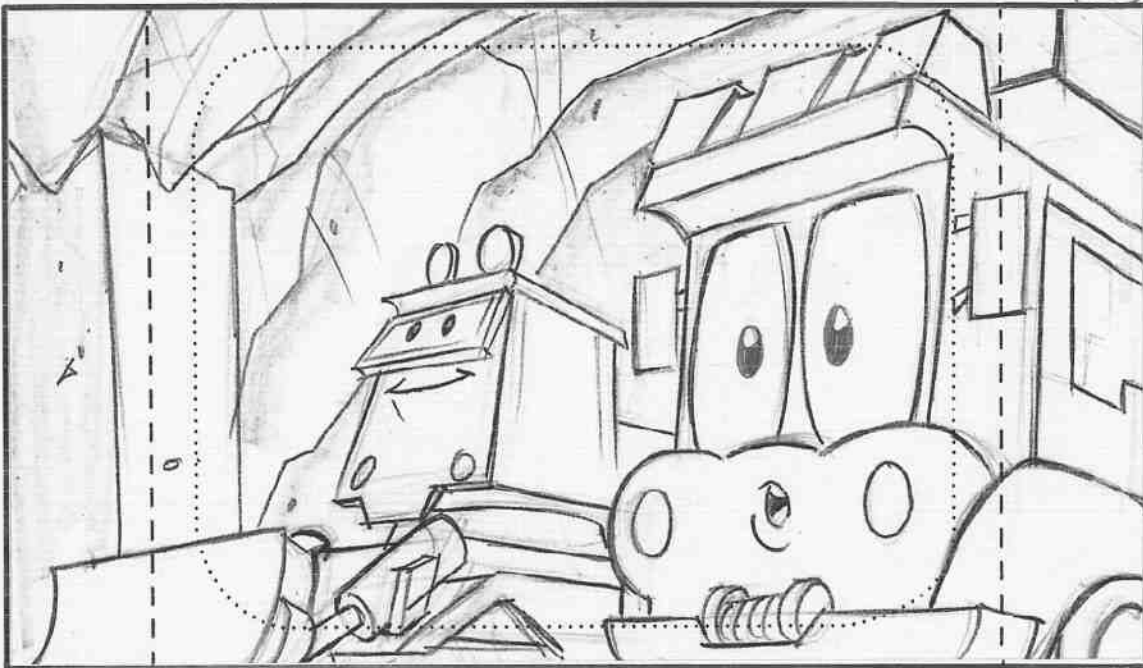

SUDDENLY THE RUMBLING STARTS AGAIN STARTLING RED.

Dialogue Action

SFX: < RUMBLING >

CUT

257-777



FIREHOUSE TALES

©2005 Warner Bros. This Material is the PROPERTY OF WARNER BROS. TELEVISION ANIMATION. It is unpublished and must not be taken from the studio, duplicated or used in any manner, except for production purposes, and may not be sold or transferred.

Sc. 50

Panel (A)

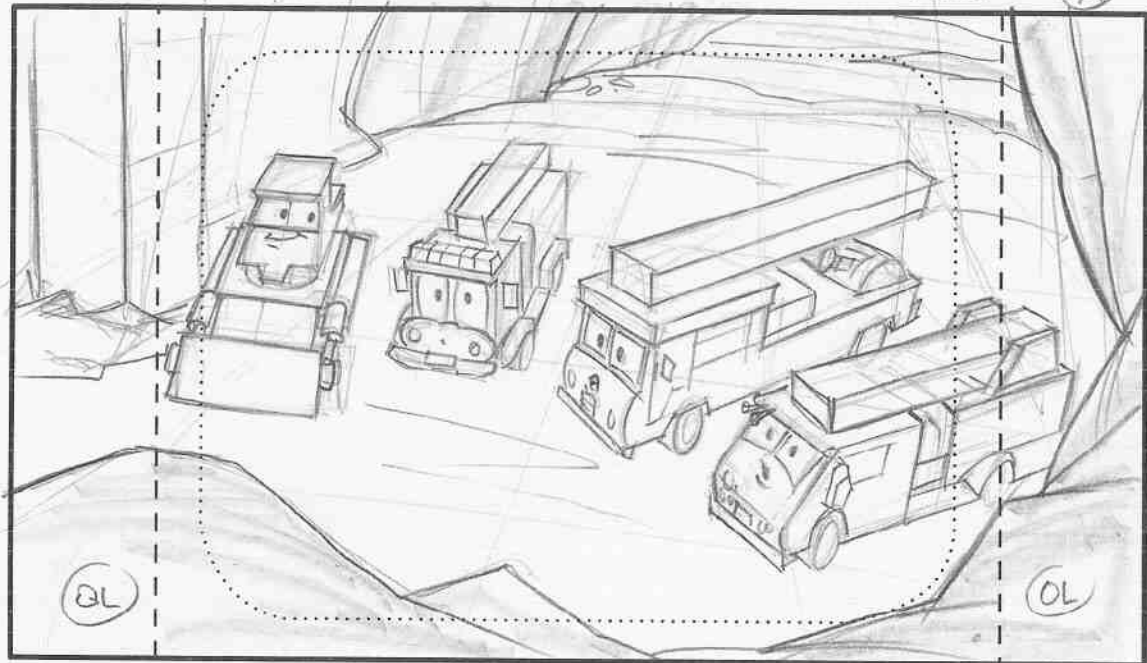

Sc. CONTD

Panel (B)

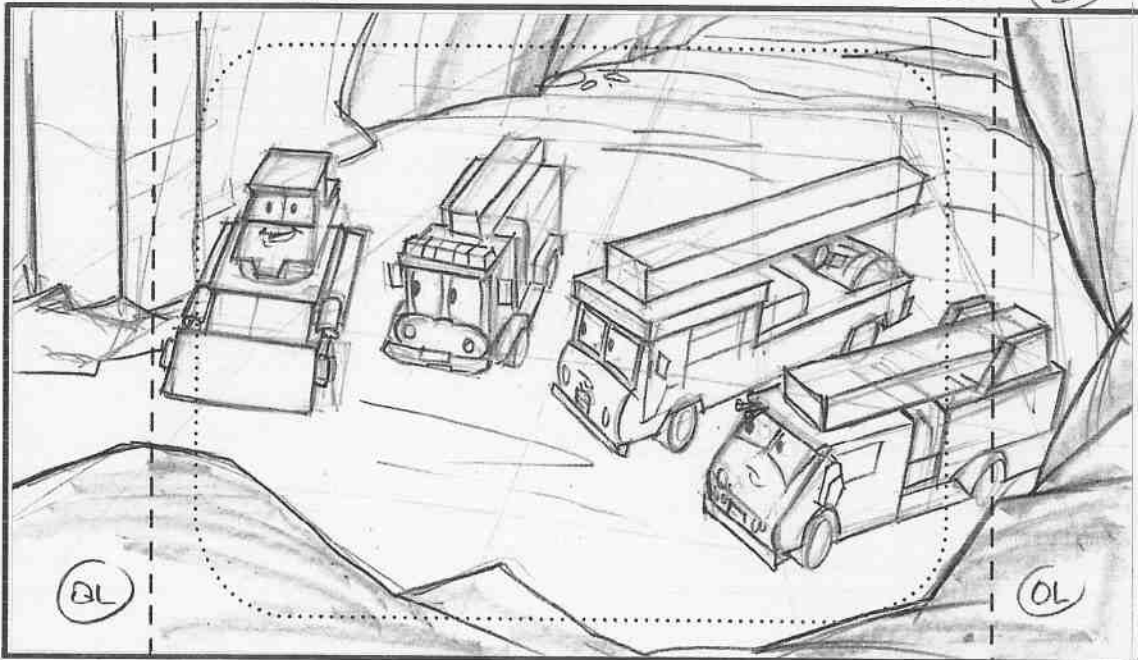

CUT

Dialogue Action

WIDE ON THE GROUP.

SFX: <RUMBLE>

(42) PETROL:

WHAT'S THAT.

Dialogue Action

(43) BUBBA:

THAT'S NOSEY!



FIREHOUSE TALES

©2005 Warner Bros. This Material is the PROPERTY OF WARNER BROS. TELEVISION ANIMATION. It is unpublished and must not be taken from the studio, duplicated or used in any manner, except for production purposes, and may not be sold or transferred.

Sc. 51

Panel

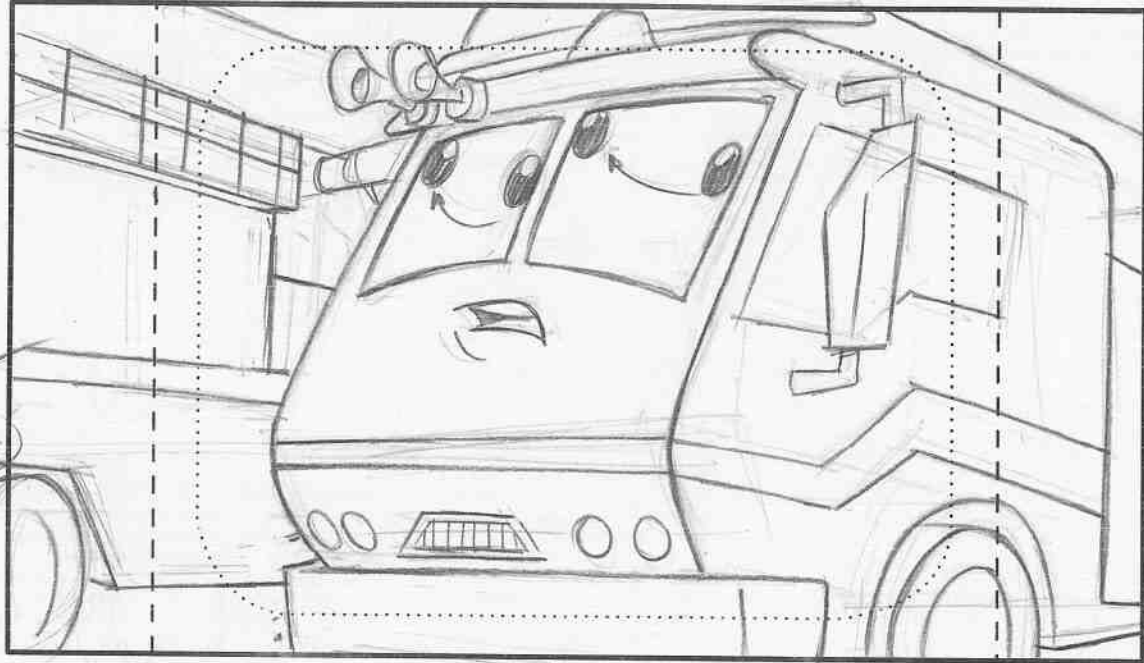

CUT CLOSE ON CRABBY, LOOKING AROUND.

Dialogue Action

SFX: < RUMBLING >

44 CRABBY:

WHERE? I DON'T SEE HIM.

Sc. 52

Panel

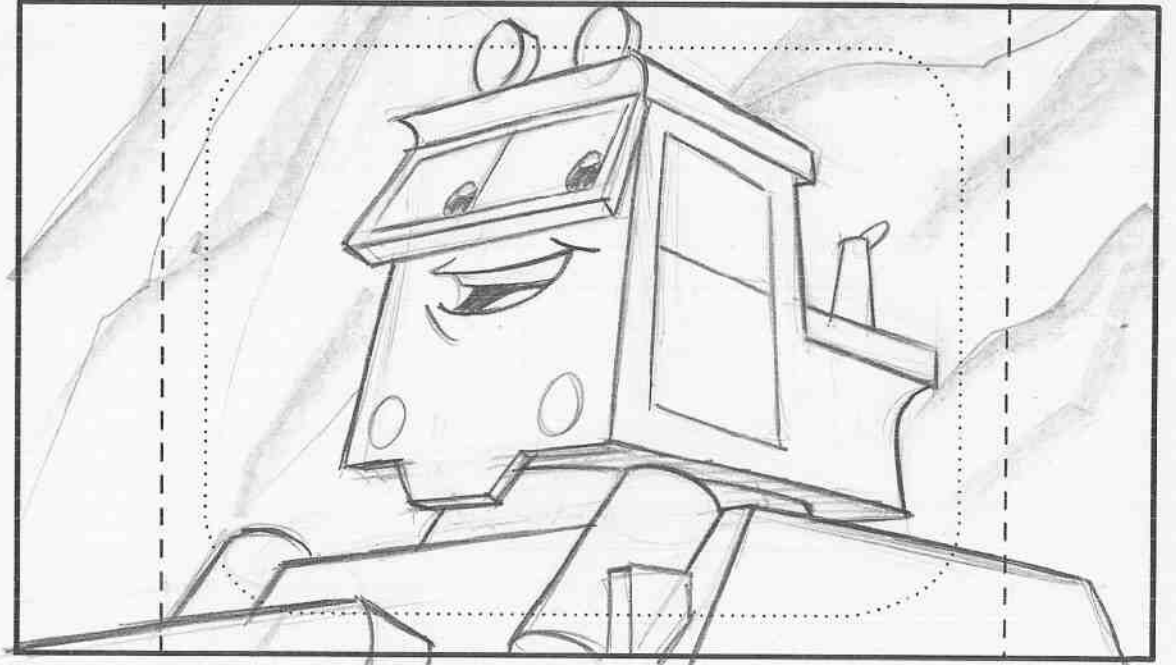

CUT CLOSE ON BUBBA

Dialogue Action

SFX: < RUMBLING >

45 BUBBA:

YOU WILL!

CUT



FIREHOUSE TALES

©2005 Warner Bros. This Material is the PROPERTY OF WARNER BROS. TELEVISION ANIMATION. It is unpublished and must not be taken from the studio, duplicated or used in any manner, except for production purposes, and may not be sold or transferred.

Sc. 53

Panel

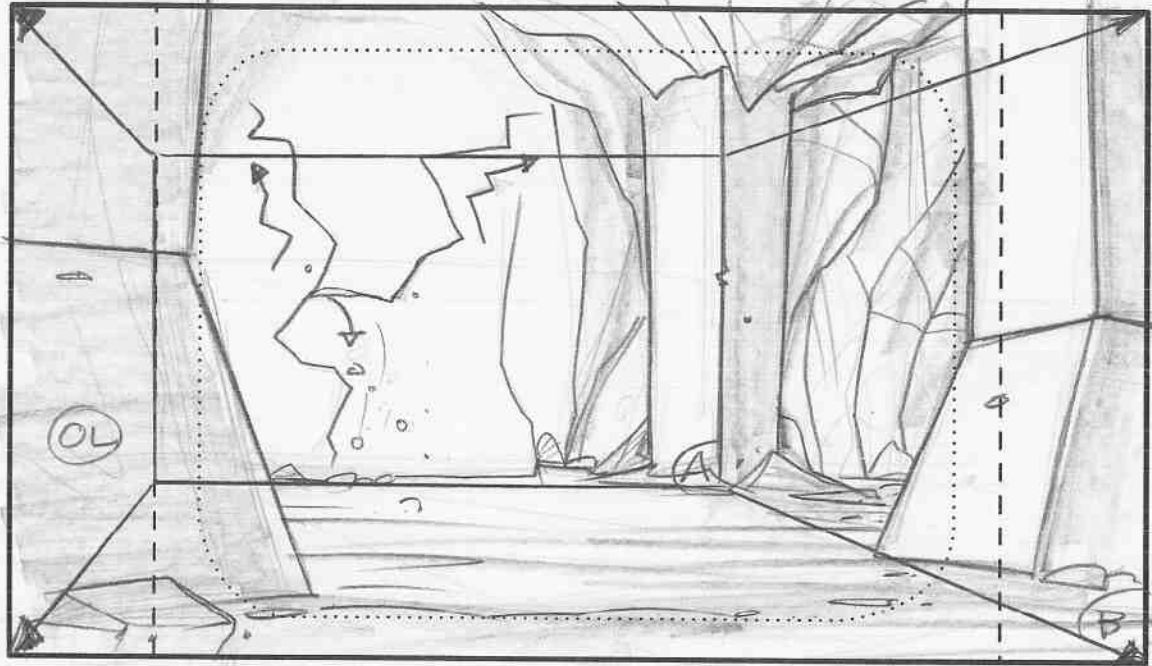

CUT
Dialogue Action ANGLE ON A SIDE WALL. A CRACK FORMS, SPREADING UP & OUT. THE RUMBLING GETS LOUDER.

SFX: <RUMBLING, ROCK CRACKING>

Sc. CONT'D

Panel (B)

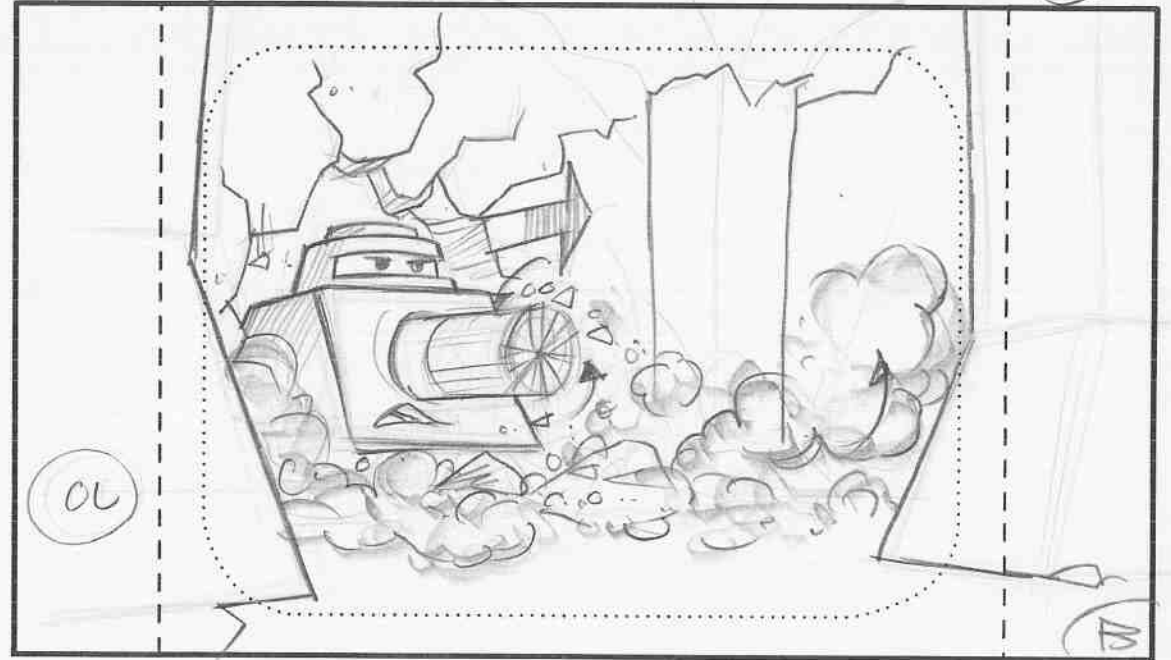

Dialogue Action TRUCK OUT (A) → (B) AS THE WALLS CRUMBLES AND NOSEY PUSHES FORWARD.

EFX: (DX DUST)
SFX: <ROCK CRUMBLING>



FIREHOUSE TALES

©2005 Warner Bros. This Material is the PROPERTY OF WARNER BROS. TELEVISION ANIMATION. It is unpublished and must not be taken from the studio, duplicated or used in any manner, except for production purposes, and may not be sold or transferred.

Sc. 53 CONTD

Panel (C)

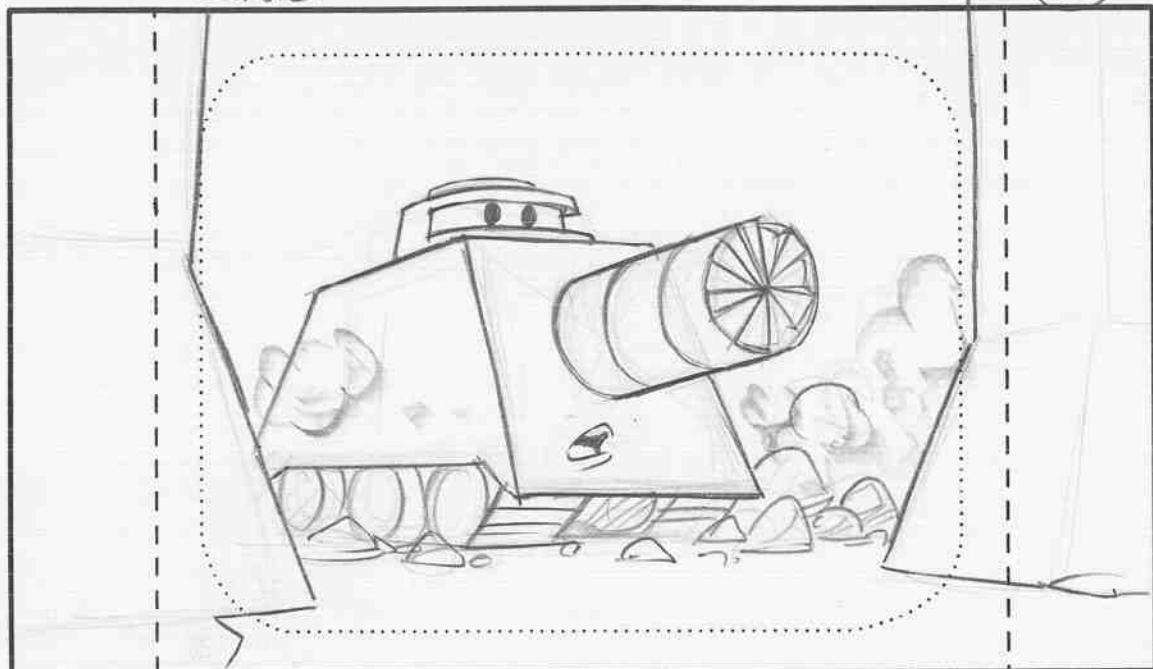

Action NOSEY'S NOSE STOPS SPINNING. HE IS SURPRISED BY THE O.S. FIRETRUCKS. THE DUST DISSIPATES.
EFX: (DX DUST)

CUT

Dialogue

(46) NOSEY:

HEY! WHO'RE THEY?

Sc. 5A

Panel

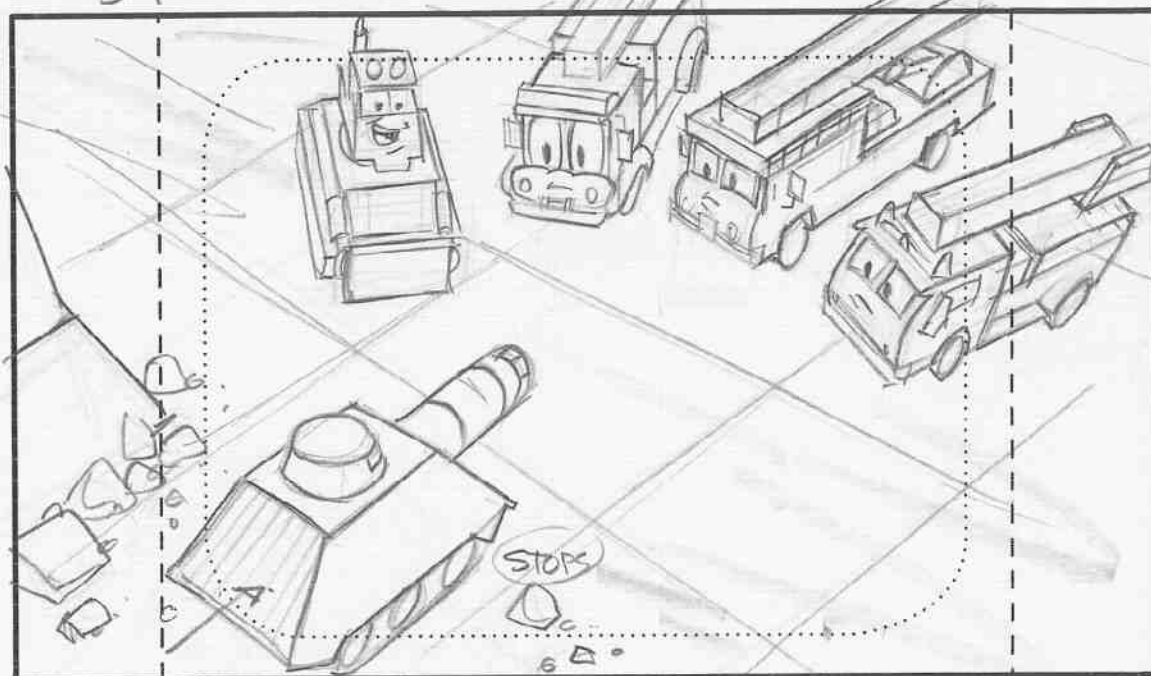

Action WIDE ON THE GROUP, NOSEY TRUNDLES CLOSER TO THE TRUCKS AND STOPS IN FRONT OF THEM. BUBBA MAKES THE INTRO'S.

CUT

Dialogue

(47) BUBBA:

THESE ARE MY FRIENDS FROM THE FIREHOUSE NOSEY. THEY, UH HAVE A LITTLE PROBLEM WITH YOU.

257-777



FIREHOUSE TALES

©2005 Warner Bros. This Material is the PROPERTY OF WARNER BROS. TELEVISION ANIMATION. It is unpublished and must not be taken from the studio, duplicated or used in any manner, except for production purposes, and may not be sold or transferred.

Sc. 55

Panel

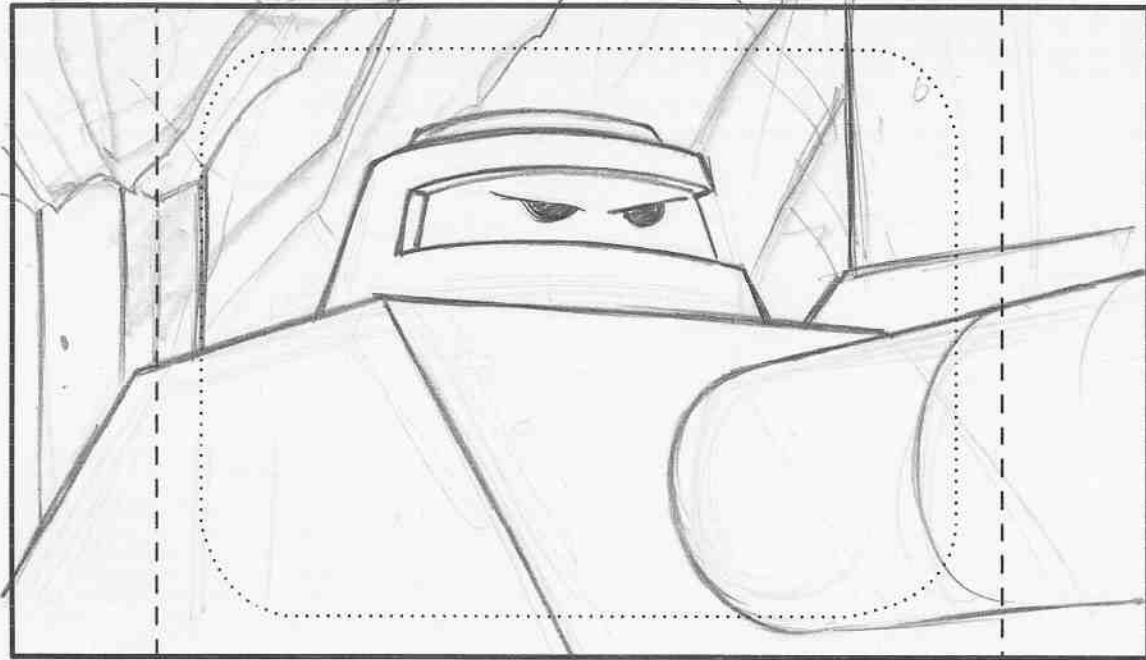

Action CLOSE ON NOSEY LOOKING ANNOYED

Dialogue (18) NOSEY:
LIKE WHAT?

Sc. 56

Panel (A)

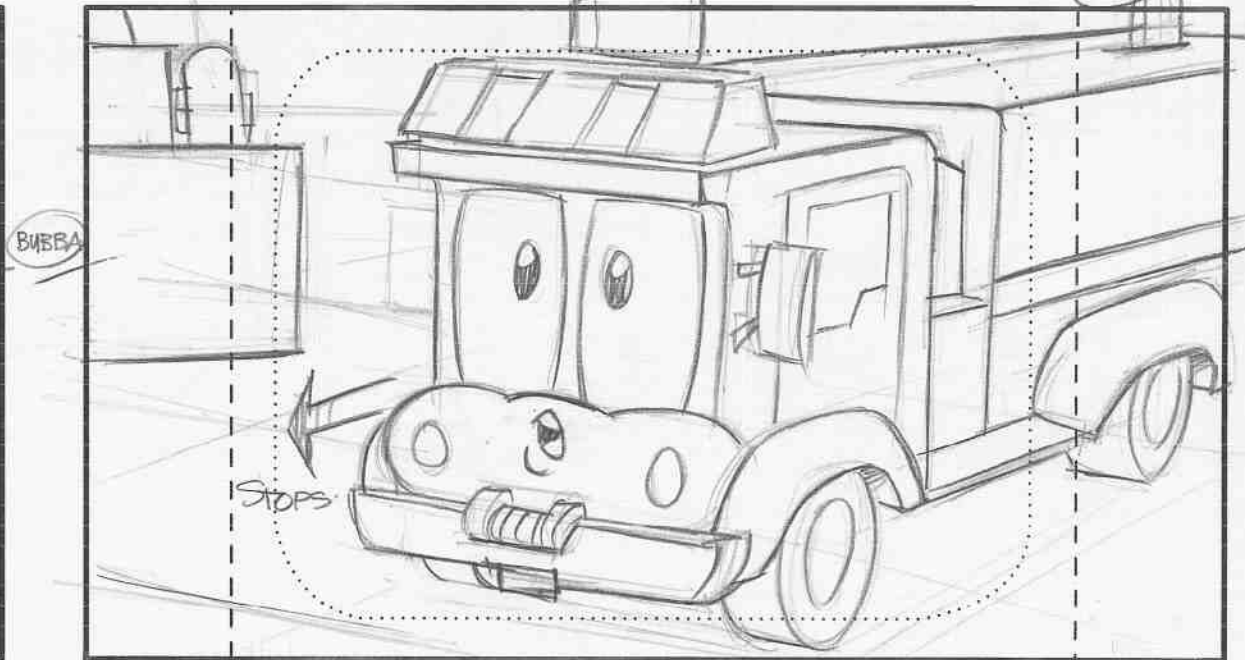

Action CLOSE ON RED. HE INCHES FORWARD. HE'S A BIT ANXIOUS.

Dialogue (19) RED:
WELL, YOU SEE MR., UH, NOSE, YOUR DRILLING IS KEEPING US UP AT NIGHT...



FIREHOUSE TALES

©2005 Warner Bros. This Material is the PROPERTY OF WARNER BROS. TELEVISION ANIMATION. It is unpublished and must not be taken from the studio, duplicated or used in any manner, except for production purposes, and may not be sold or transferred.

Sc. 57 CONTD

Panel (B)

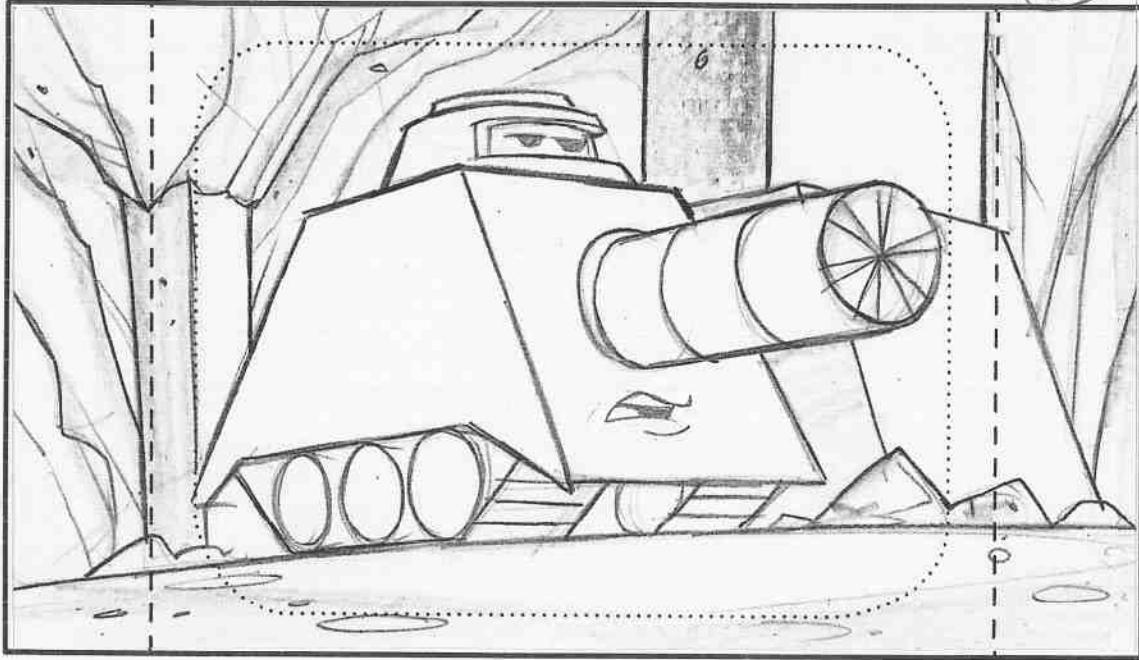

Dialogue Action

NOSEY HARDENS.

(50) NOSEY: (CONTD)

.. BUT THERE'S NOTHING I CAN DO ABOUT IT!

Sc. CONTD.

Panel (C)

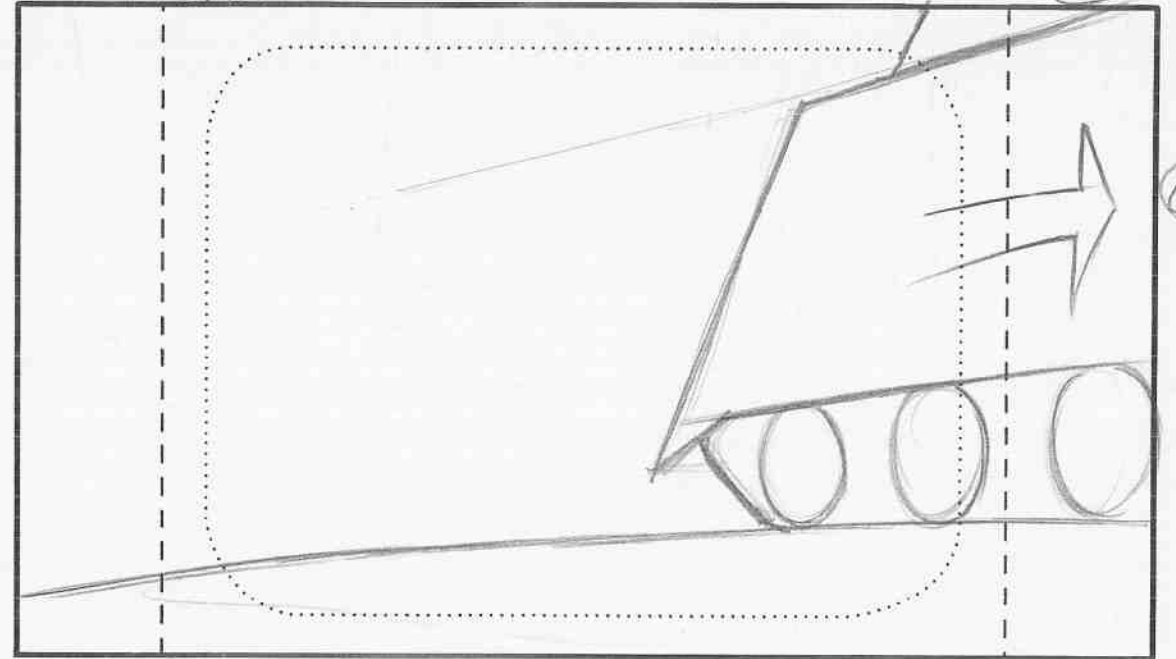

Dialogue Action

NOSEY FUMBLES FORWARD.

SFX: < ENGINE RUMBLE >

OUT

CUT

257-777



FIREHOUSE TALES

©2005 Warner Bros. This Material is the PROPERTY OF WARNER BROS. TELEVISION ANIMATION. It is unpublished and must not be taken from the studio, duplicated or used in any manner, except for production purposes, and may not be sold or transferred.

Sc. 58

Panel A

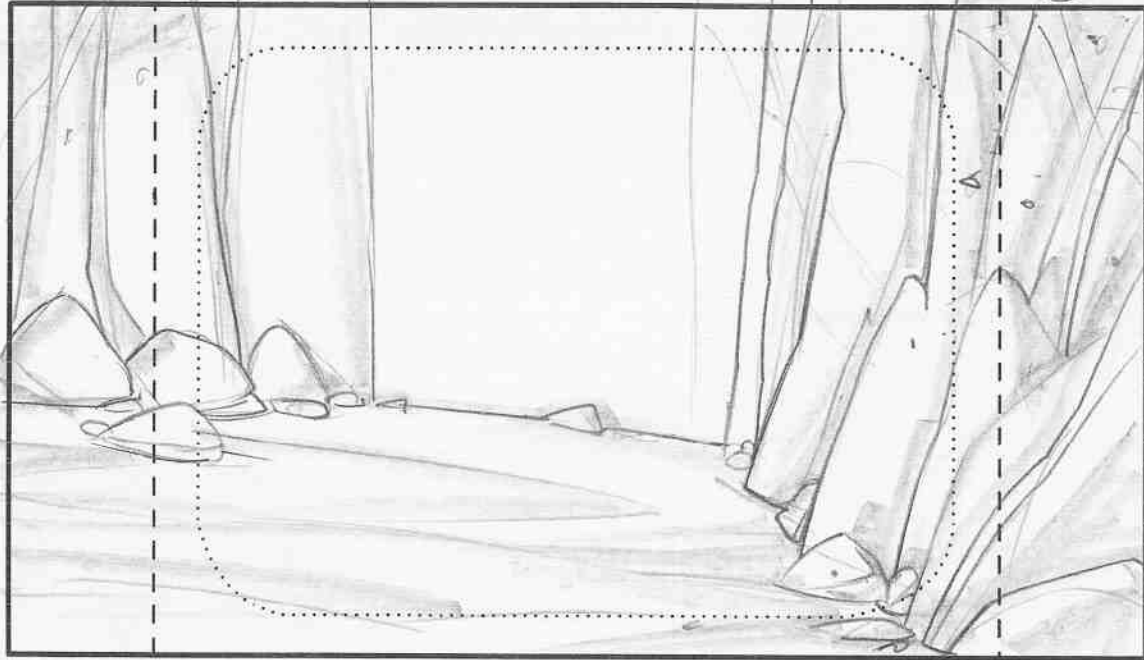

CUT

Dialogue Action

ANGLE ON A WALL OF ROCK

SFX: < RUMBLE >

Sc.

CONTD

Panel B

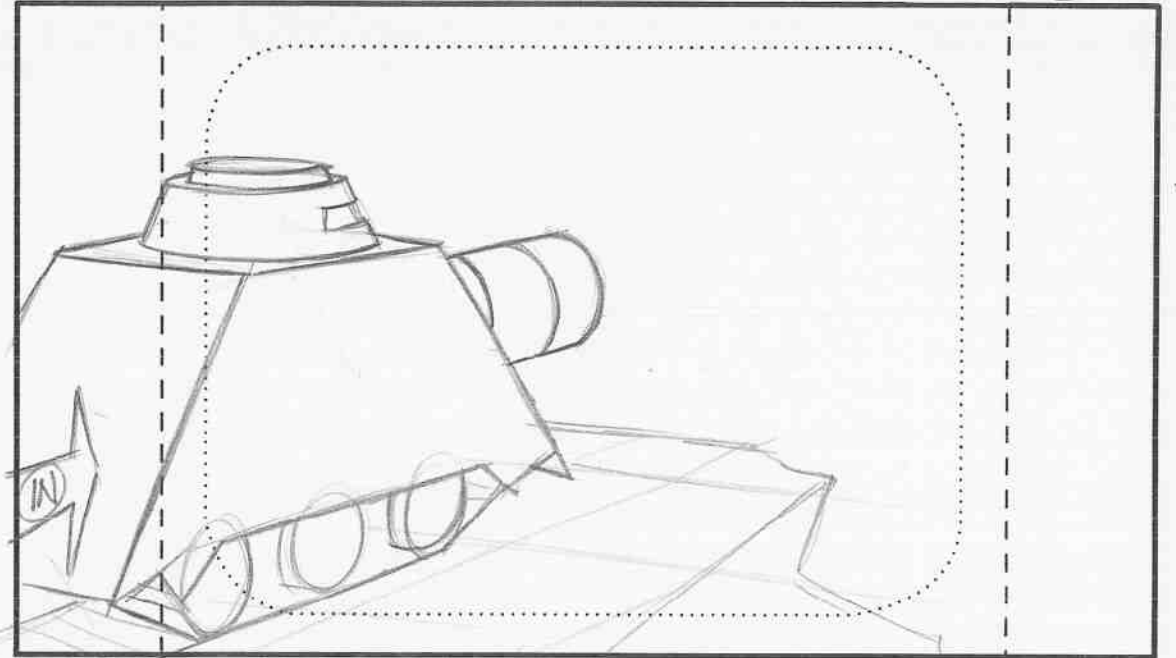

CUT

Dialogue Action

NOSEY RUMBLES INTO SCENE AND STOPS IN FRONT OF THE WALL

SFX: < ENGINE IDLE >



FIREHOUSE TALES

©2005 Warner Bros. This Material is the PROPERTY OF WARNER BROS. TELEVISION ANIMATION. It is unpublished and must not be taken from the studio, duplicated or used in any manner, except for production purposes, and may not be sold or transferred.

Page 64

Sc. 59

Panel

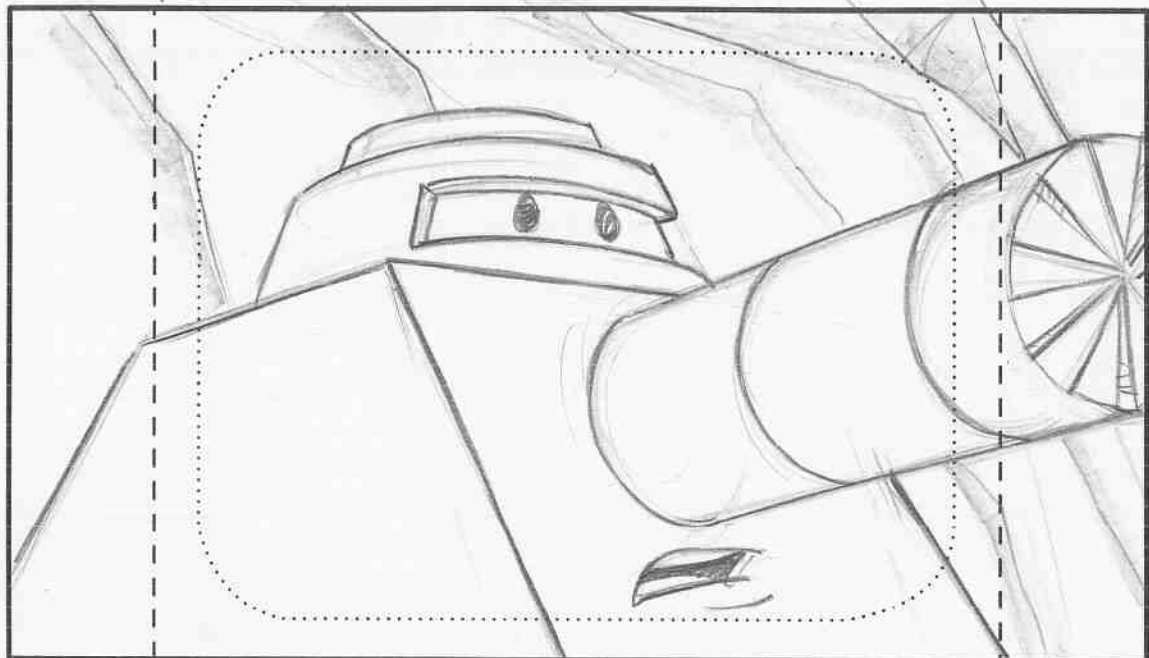

ANGLE ON NOSEY (SLIGHT UPSHOT)

CUT
Dialogue Action

Sc. 60

Panel

(A)

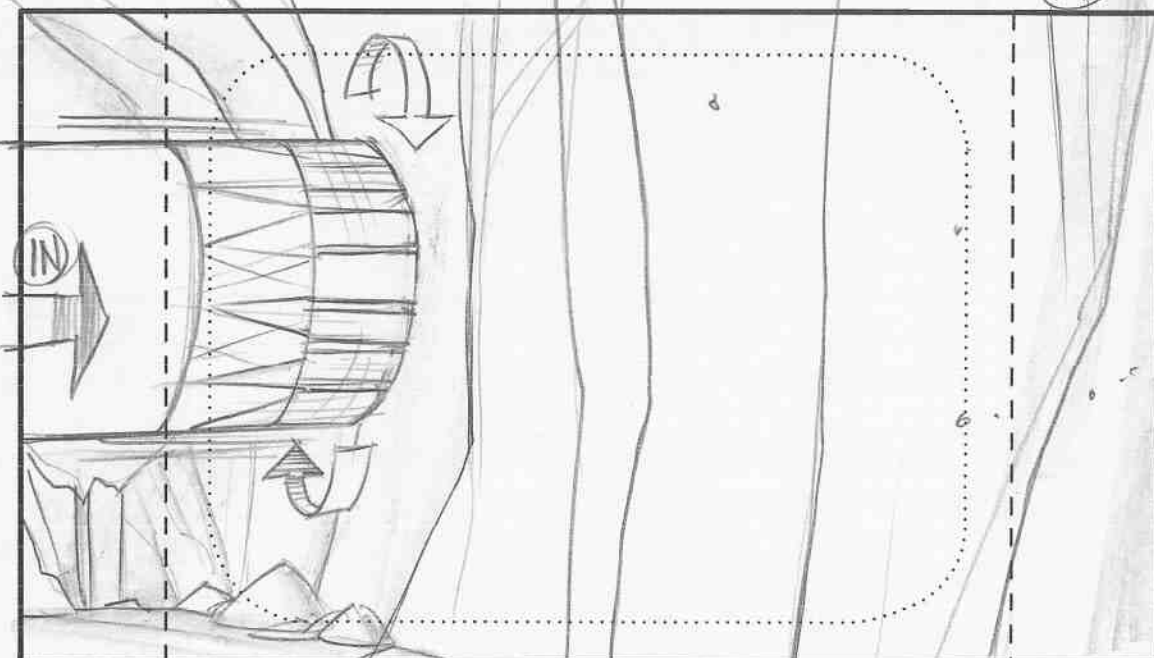

CLOSE ON THE ROCK WALL - NOSEY'S SPINNING NOSE ENTERS.

CUT

Dialogue Action

SFX: <BIG DRILL SOUND> EFX: (BLUR)

257-777



FIREHOUSE TALES

©2005 Warner Bros. This Material is the PROPERTY OF WARNER BROS. TELEVISION ANIMATION. It is unpublished and must not be taken from the studio, duplicated or used in any manner, except for production purposes, and may not be sold or transferred.

Sc. 60 CONTD.

Panel (B)

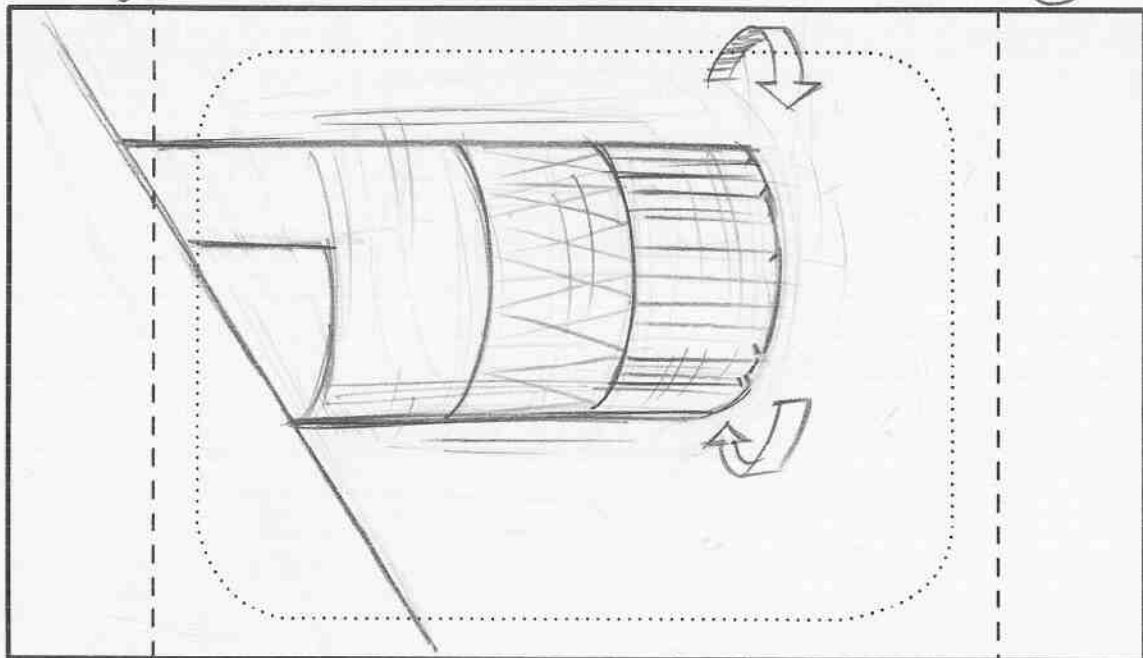

Dialogue Action NOSEY'S NOSE TOUCHES THE WALL. IT DOESN'T EVEN LEAVE A SCRATCH.

SFX: <ROCK DRILLING>

(52) NOSEY:
(GRUNTING AND EFFORTS)

Sc. 61

Panel



Dialogue Action ANGLE ON THE TRUCKS STARING IN AMAZEMENT.

SFX: <DRILLING>

(52) NOSEY: (OS CONT'D)
(GRUNTING AND EFFORTS)

CUT

CUT

257-777



FIREHOUSE TALES

©2005 Warner Bros. This Material is the PROPERTY OF WARNER BROS. TELEVISION ANIMATION. It is unpublished and must not be taken from the studio, duplicated or used in any manner, except for production purposes, and may not be sold or transferred.

Page 66

Sc. 62

Panel A

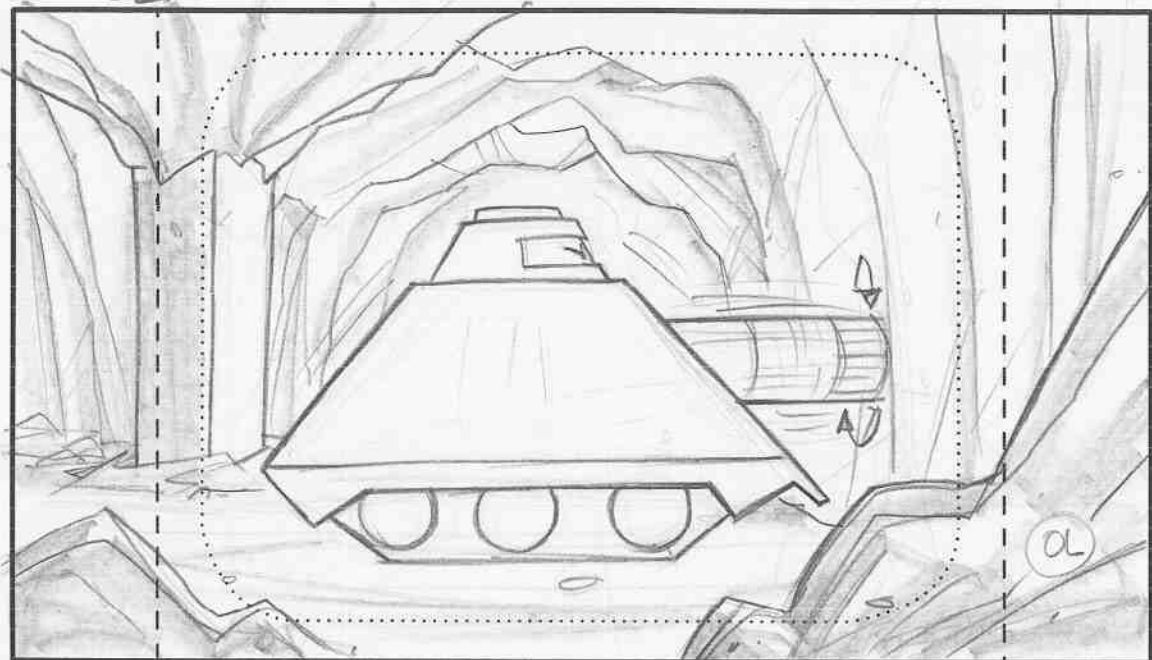

CUT

Action ANGLE ON NOSEY TRYING TO DRILL INTO THE HARD ROCK WALL.

SFX: <ROCK DRILLING> EFX: (BLUR)

Dialogue (52) NOSEY: (CONTD)

(GRUNTING AND EFFORTS)

Sc.

CONTD.

Panel B

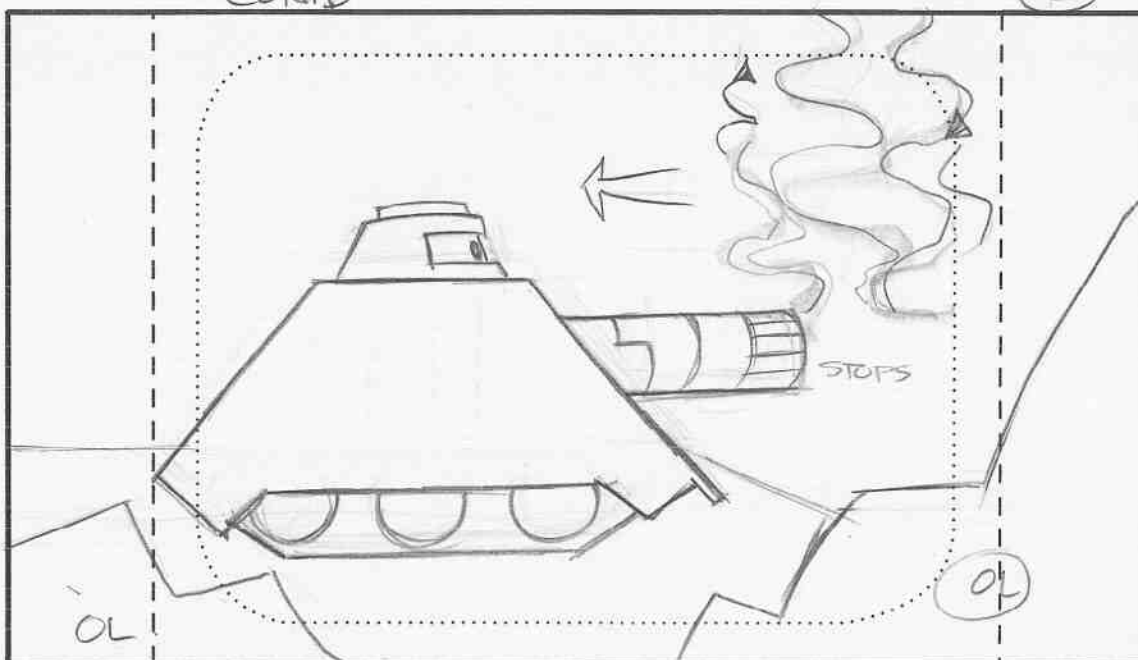

Action NOSEY STOPS DRILLING AND BACKS AWAY FROM THE WALL. A THIN TENDRIL OF SMOKE RISES FROM THE WALL AND NOSEY'S NOSE, WHICH STOPS SPINNING.

EFX: (DX SMOKE)

CUT

257-777



FIREHOUSE TALES

©2005 Warner Bros. This Material is the PROPERTY OF WARNER BROS. TELEVISION ANIMATION. It is unpublished and must not be taken from the studio, duplicated or used in any manner, except for production purposes, and may not be sold or transferred.

Sc. 64

SABG 61

Panel A

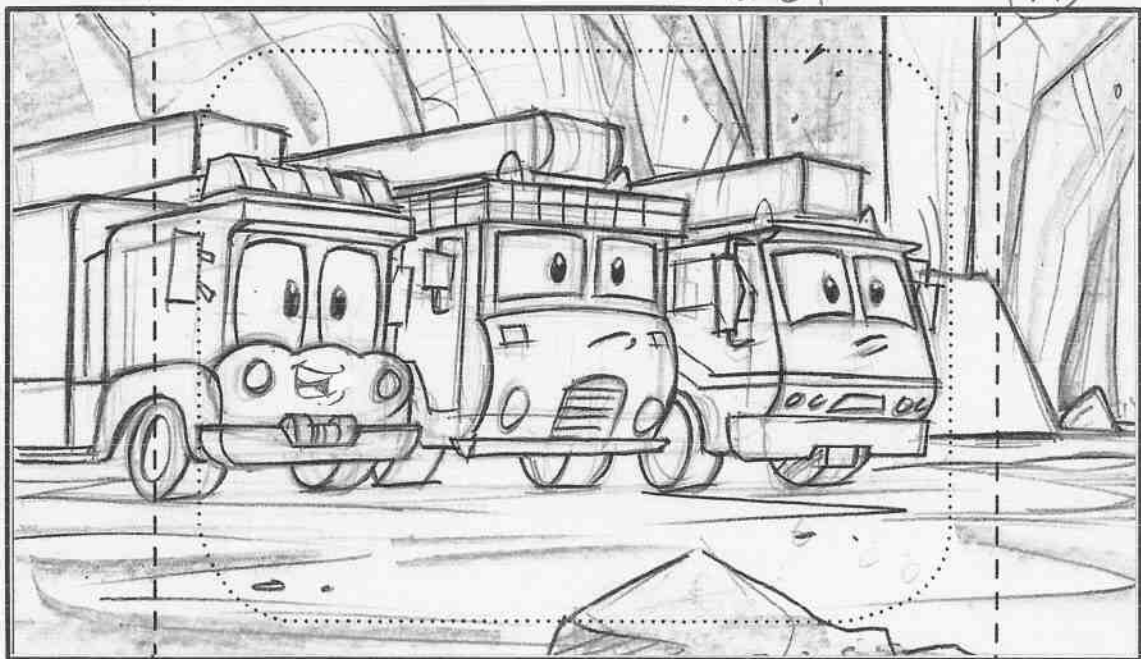

CUT

Action WIDE ON THE THREE TRUCKS.
RED HAS AN IDEA. CRABBY REACTS TO WHAT RED SAYS.

Dialogue (54) RED:
MAYBE WE CAN HELP YOU!

Sc.

CONTD.

Panel B



Action CRABBY & PETROL LOOK OVER AT RED.

Dialogue (55) CRABBY:
WE CAN?.

CUT

257-777



FIREHOUSE TALES

©2005 Warner Bros. This Material is the PROPERTY OF WARNER BROS. TELEVISION ANIMATION. It is unpublished and must not be taken from the studio, duplicated or used in any manner, except for production purposes, and may not be sold or transferred.

Sc. 65

Panel A

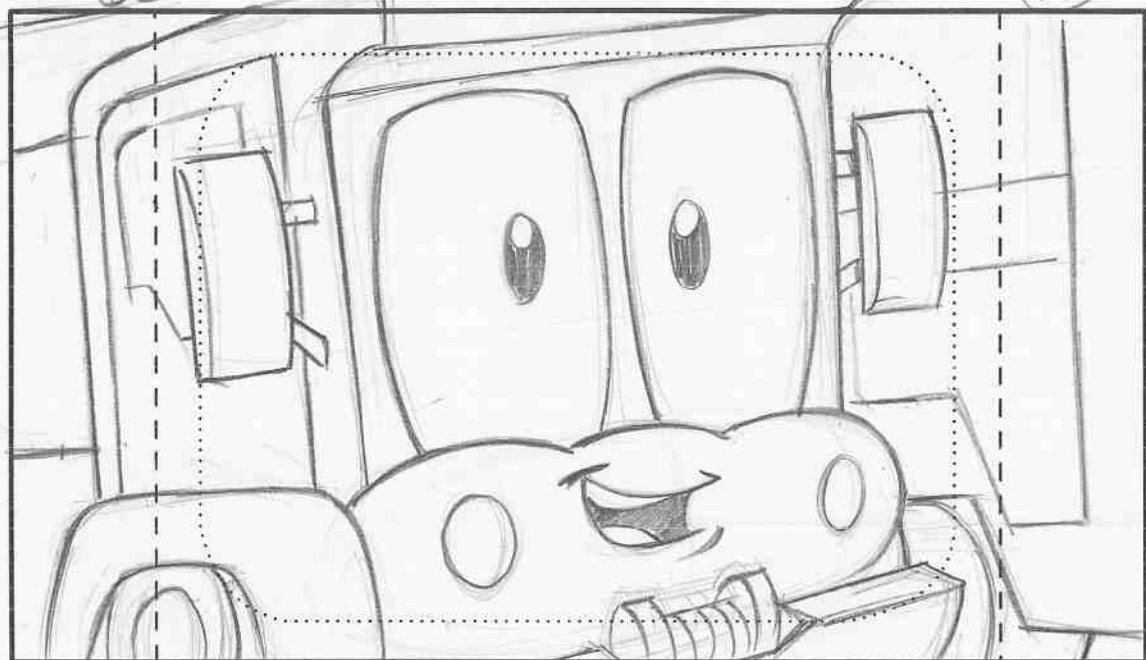

CLOSE ON RED .

CUT
Dialogue Action

56 RED :

SURE.

Sc. CONTD .

Panel B

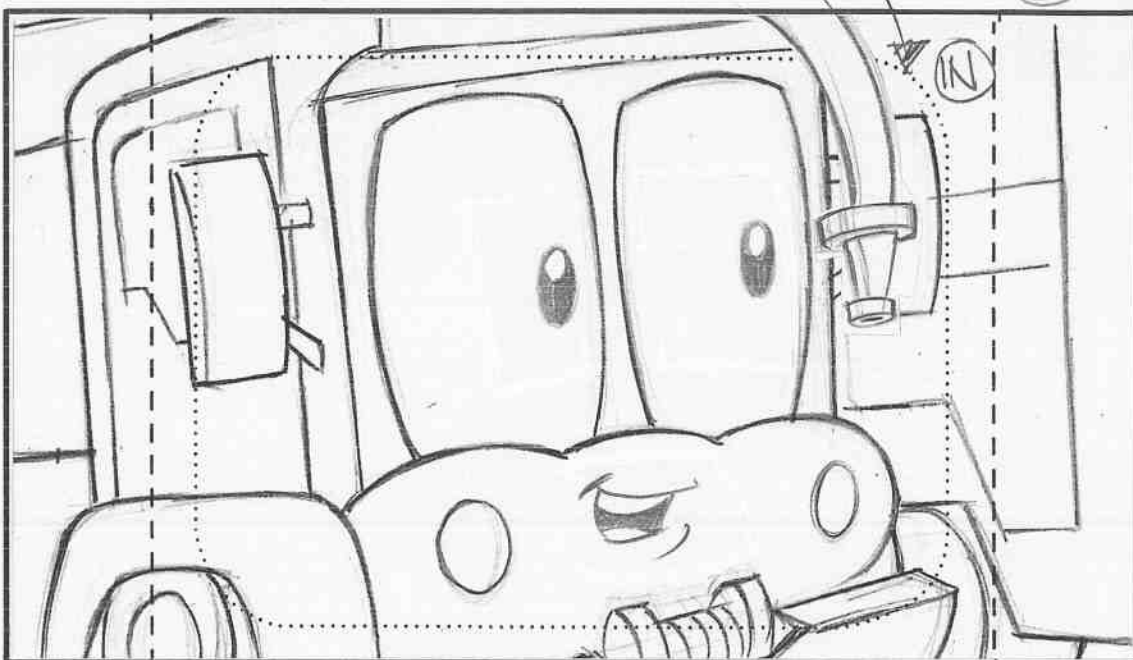

RED'S HOSE SNAKES INTO FRAME

CUT
Dialogue Action

56 RED: (CONTD) .

IF WE SPRAY NOSEY'S NOSE WITH WATER WHILE HE'S DRILLING, WE CAN KEEP IT COOL.



FIREHOUSE TALES

©2005 Warner Bros. This Material is the PROPERTY OF WARNER BROS. TELEVISION ANIMATION. It is unpublished and must not be taken from the studio, duplicated or used in any manner, except for production purposes, and may not be sold or transferred.

Sc. 66

S/ABG 59

Panel (A)

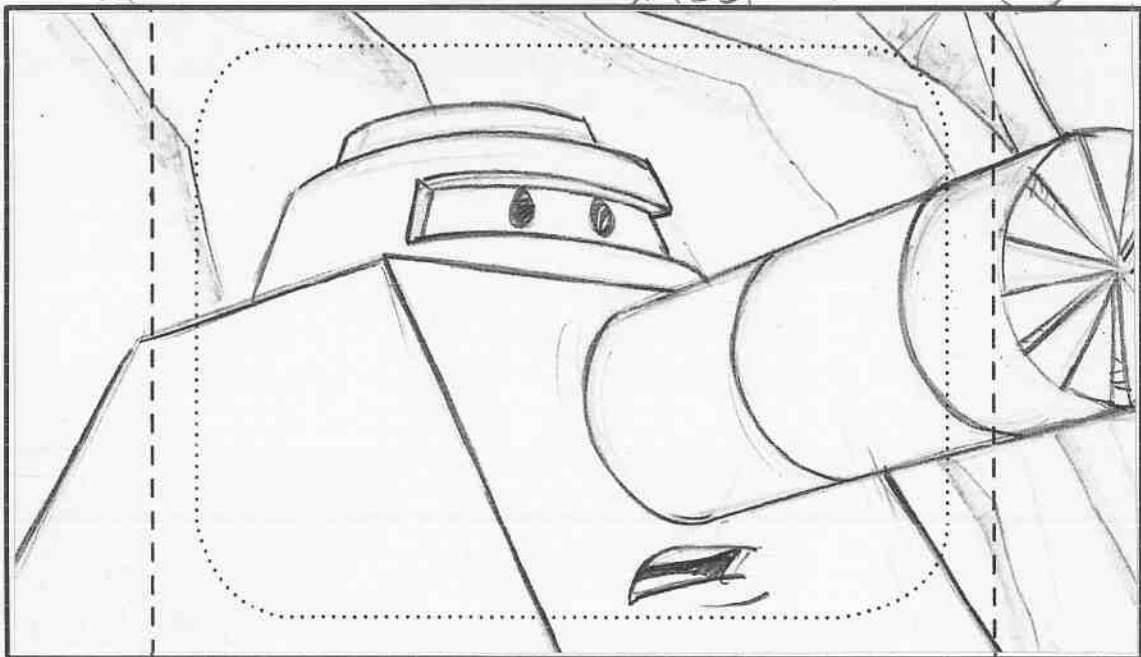

CUT

Dialogue Action

CLOSE ON NOSEY. HE SCEPTICAL.

(57) NOSEY:

IT'S WORTH A TRY.

Sc. 67

Panel (A)

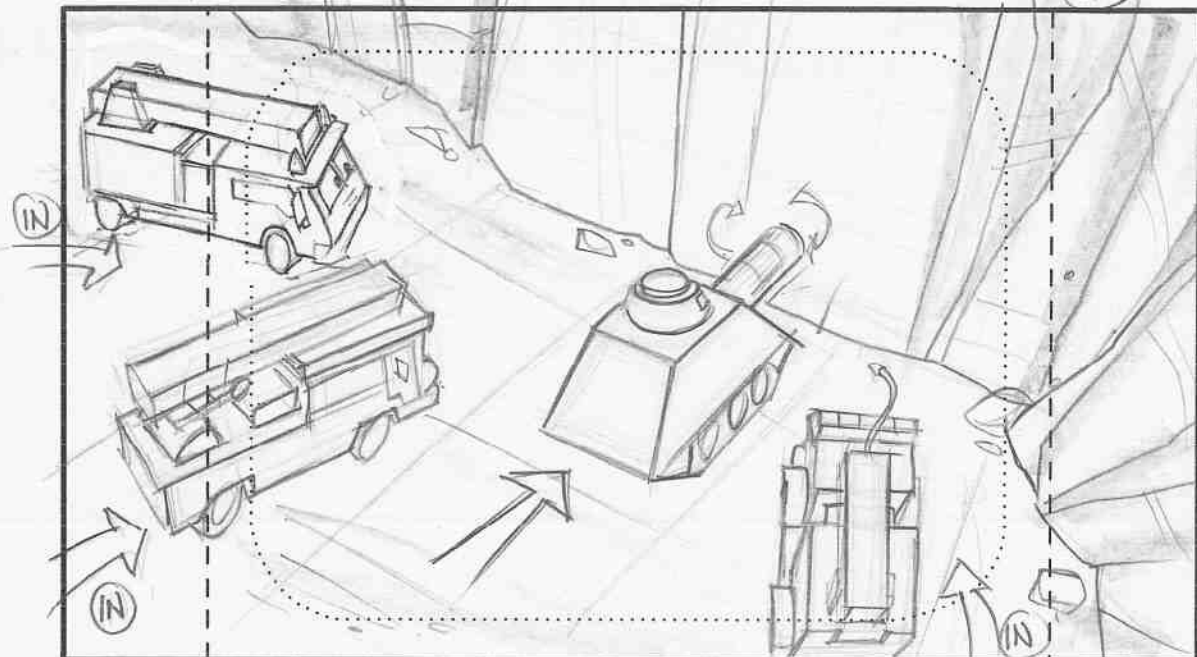

CUT

Dialogue Action

WIDE ON ROCK WALL. NOSEY MOVES INTO POSITION. RED, PETROL & CRABBY DRIVE UP BESIDE HIM. EFX: (BLUR). NOSEY'S NOSE STARTS TO SPIN.

SFX: <DRILL WHIRR>

257-777



FIREHOUSE TALES

©2005 Warner Bros. This Material is the PROPERTY OF WARNER BROS. TELEVISION ANIMATION. It is unpublished and must not be taken from the studio, duplicated or used in any manner, except for production purposes, and may not be sold or transferred.

Sc. 63

S/A BG 59

Panel (A)

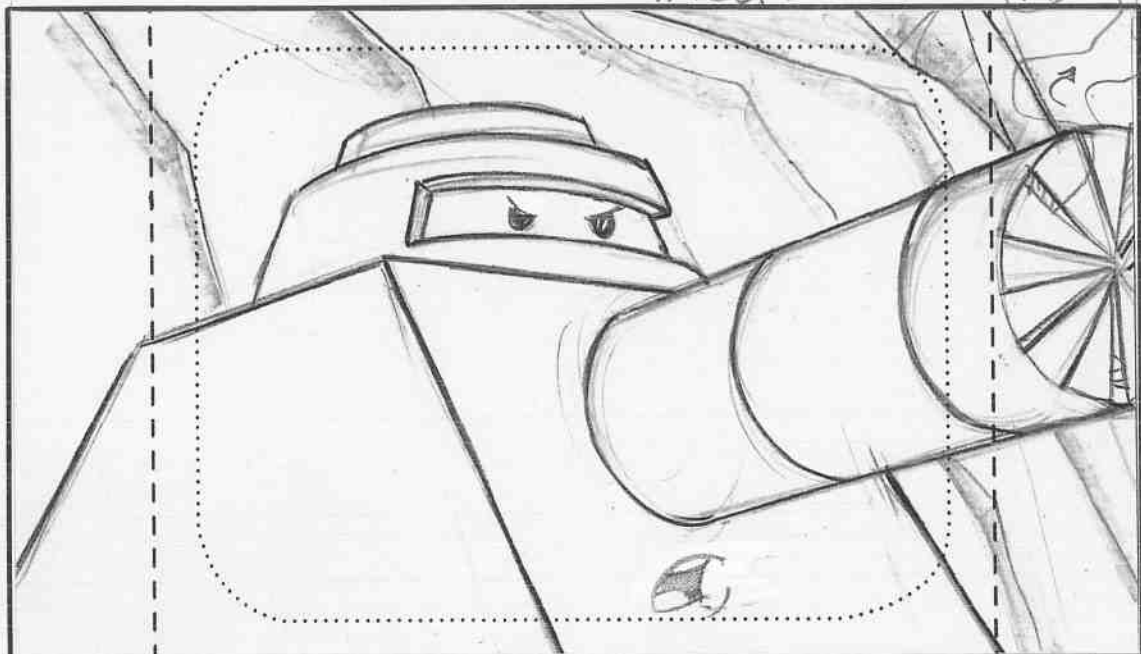

CUT

Action CLOSE ON NOSEY. HE LOOKS FRUSTRATED (SMOKE OFF NOSE DISSIPATES)
EFX: (DX SMOKE)

Dialogue (53) NOSEY:
IT HEATS UP MY NOSE & BOY DOES THAT HURT.

Sc.

CONTD.

Panel (B)

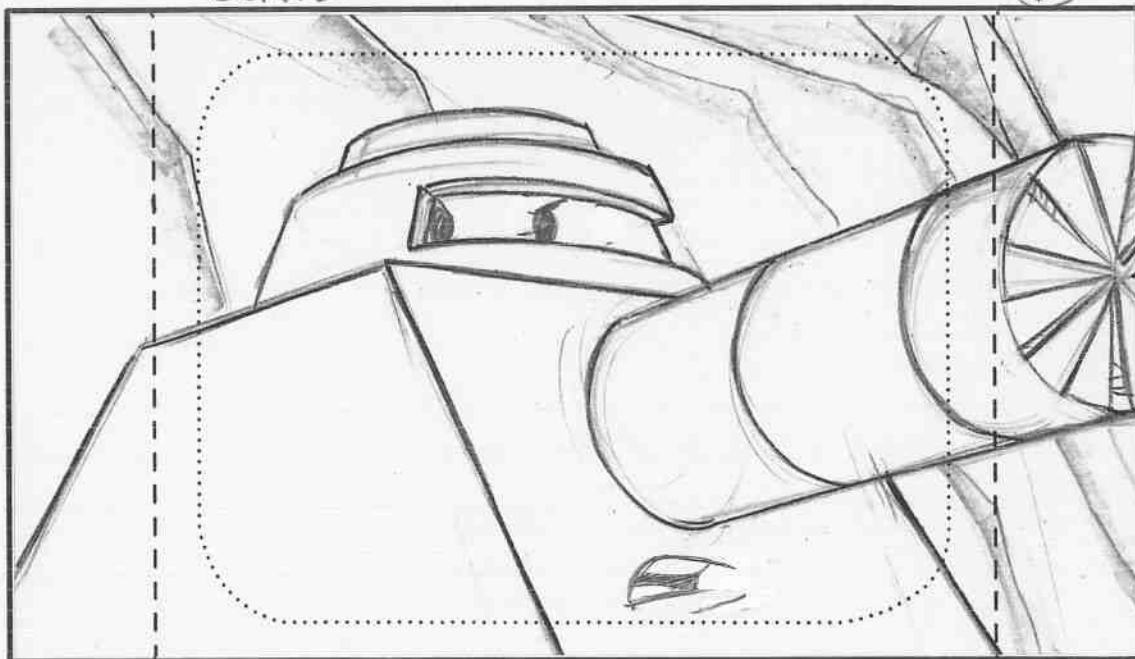

Action NOSEY LOOKS BACK AT THE OS FIRETRUCKS.

Dialogue (53) NOSEY: (CONTD)
.. AT THIS RATE THE JOBS GONNA TAKE FOREVER.

CUT

257-777



FIREHOUSE TALES

©2005 Warner Bros. This Material is the PROPERTY OF WARNER BROS. TELEVISION ANIMATION. It is unpublished and must not be taken from the studio, duplicated or used in any manner, except for production purposes, and may not be sold or transferred.

Sc. 67 CONTD

Panel

(B)

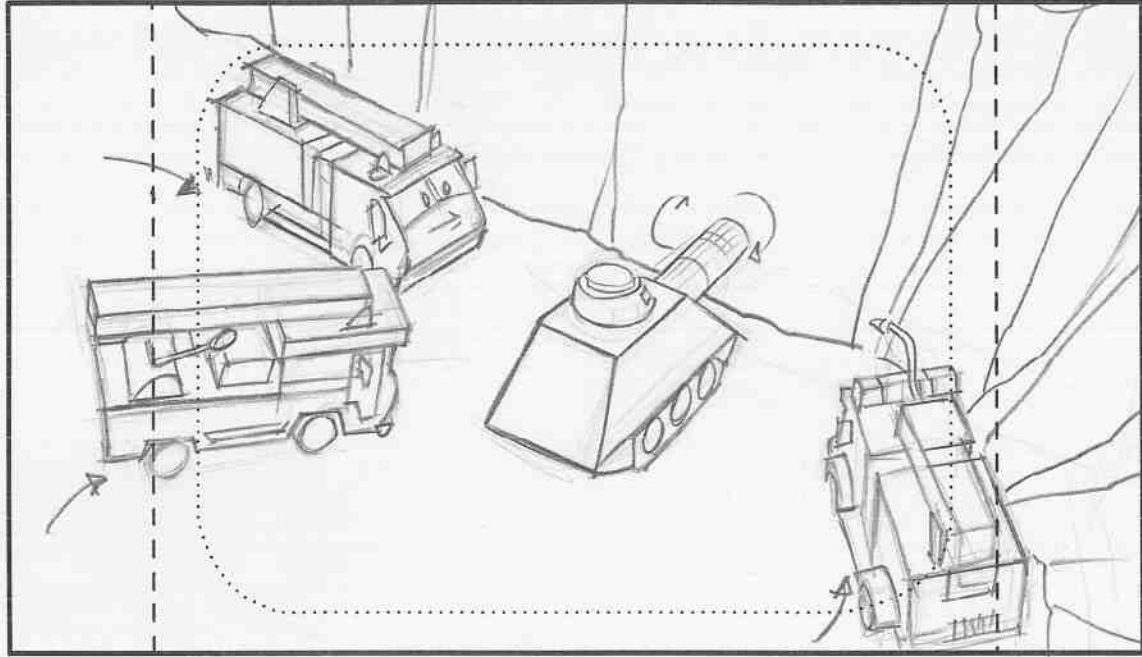

Dialogue Action

THE TRUCKS SETTLE INTO PLACE

(CUT)

Sc. 68

Panel

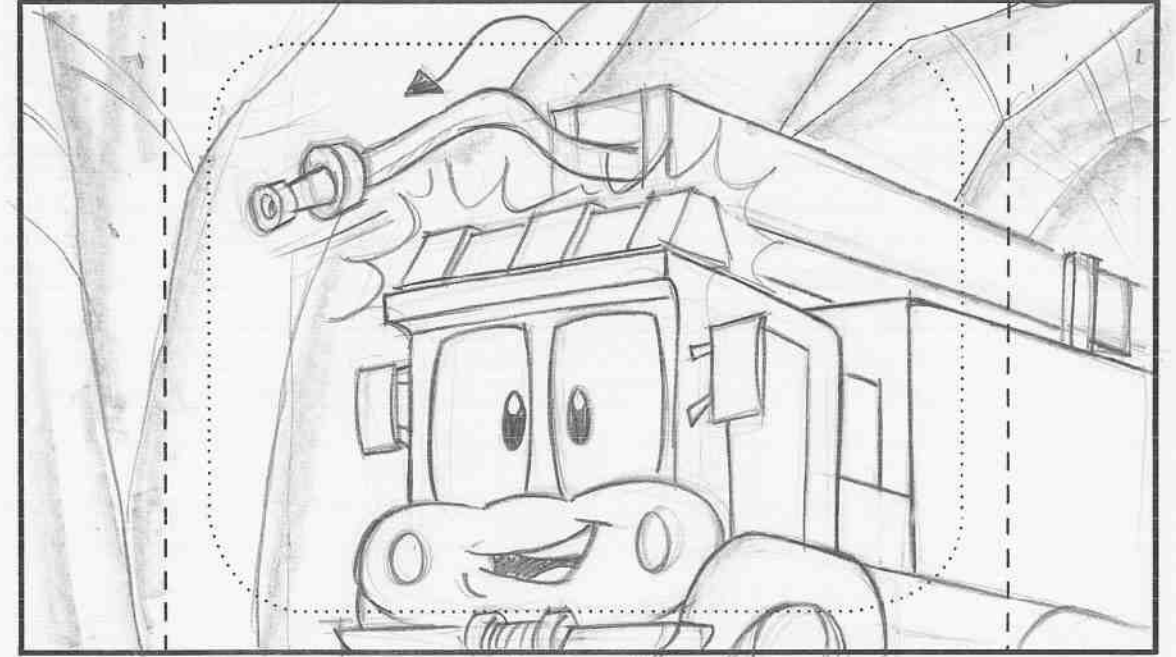

Dialogue Action

CLOSE ON RED. HIS LIGHTS START FLASHING AND HIS HOSE MOVES FORWARD

EPX: (BOT. LIT LIGHTS) SFX: (SIRENS)

(CUT)

(58) RED:

THE SIRENS SAY, ITS TIME TO SPRAY!

257-777



FIREHOUSE TALES

©2005 Warner Bros. This Material is the PROPERTY OF WARNER BROS. TELEVISION ANIMATION. It is unpublished and must not be taken from the studio, duplicated or used in any manner, except for production purposes, and may not be sold or transferred.

Sc. 69

Panel

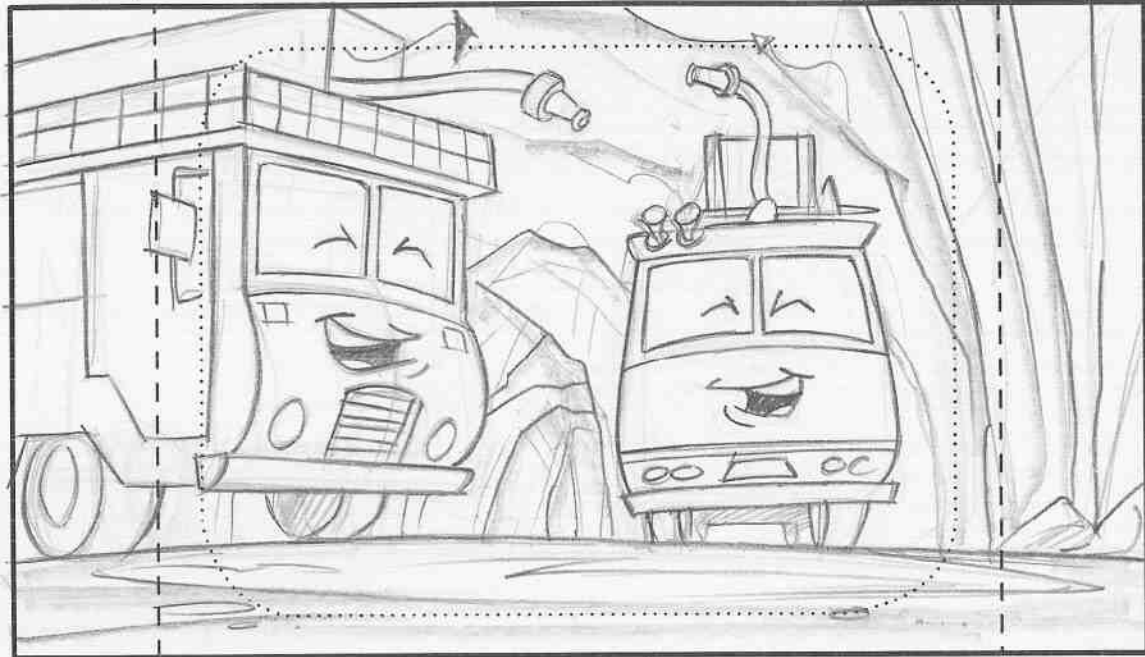

CUT

Action
Dialogue

ANGLE ON PETROL & CRABBY GIGGLING AT WHAT RED JUST SAID. THEY EXTEND THEIR HOSES.

59 PETROL/CRABBY:
(CHUCKLES)

CUT

Sc. 70

SA BG 67 Panel

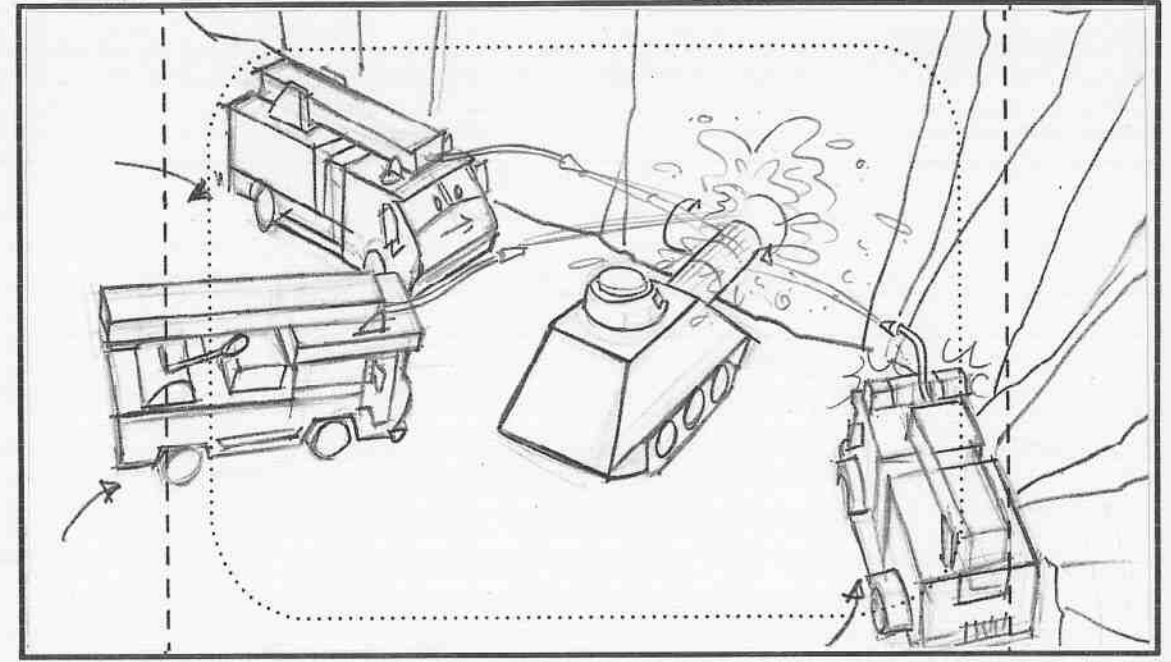

Action
Dialogue

WIDE ON GROUP. THE TRUCKS SPRAY WATER ONTO NOSEY'S SPINNING NOSE.

EFX: (S/T WATER, BOT. LITE LIGHTS, BLUR)
SFX < WATER SPRAYING, ROCK DRILLING >

CUT

257-777



FIREHOUSE TALES

©2005 Warner Bros. This Material is the PROPERTY OF WARNER BROS. TELEVISION ANIMATION. It is unpublished and must not be taken from the studio, duplicated or used in any manner, except for production purposes, and may not be sold or transferred.

Sc. 71

Panel (A)

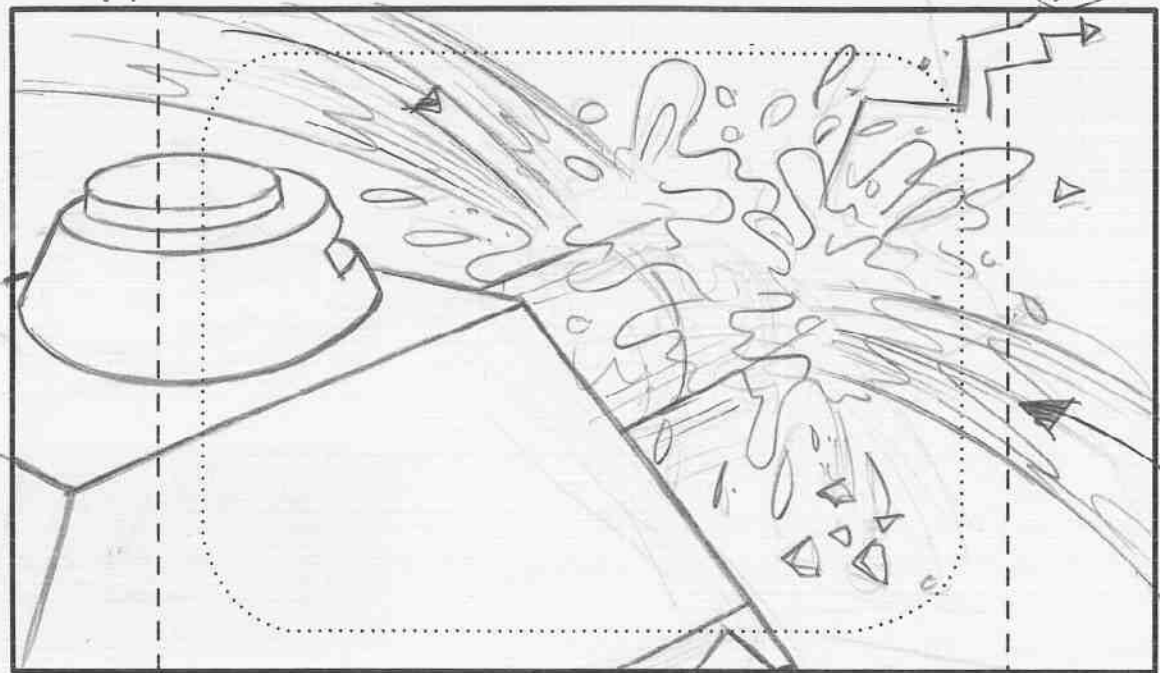

CUT

Action CLOSER ON NOSEY. THE ROCK BEGINS TO CRACK. THE FIRETRUCKS POUR ON THE WATER.

Dialogue EFX: (S/T WATER, BLUR)
SFX: (ROCK DRILLING, WATER SPRAY)

Sc.

CONTD

Panel (B)

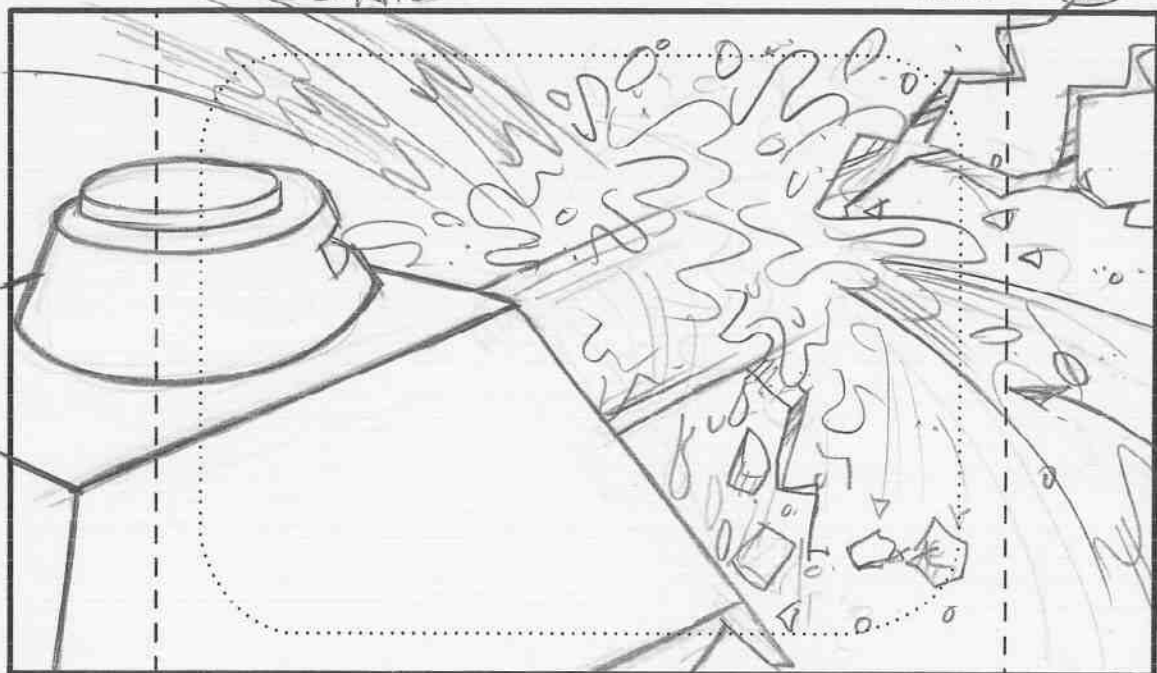

Action THE CRACK WIDENS, CHIPS FLY.

Dialogue (60) NOSEY: (VO)
HEY IT'S WORKIN'! KEEP SPRAYING.



FIREHOUSE TALES

©2005 Warner Bros. This Material is the PROPERTY OF WARNER BROS. TELEVISION ANIMATION. It is unpublished and must not be taken from the studio, duplicated or used in any manner, except for production purposes, and may not be sold or transferred.

Sc. 71 CONTD

Panel C

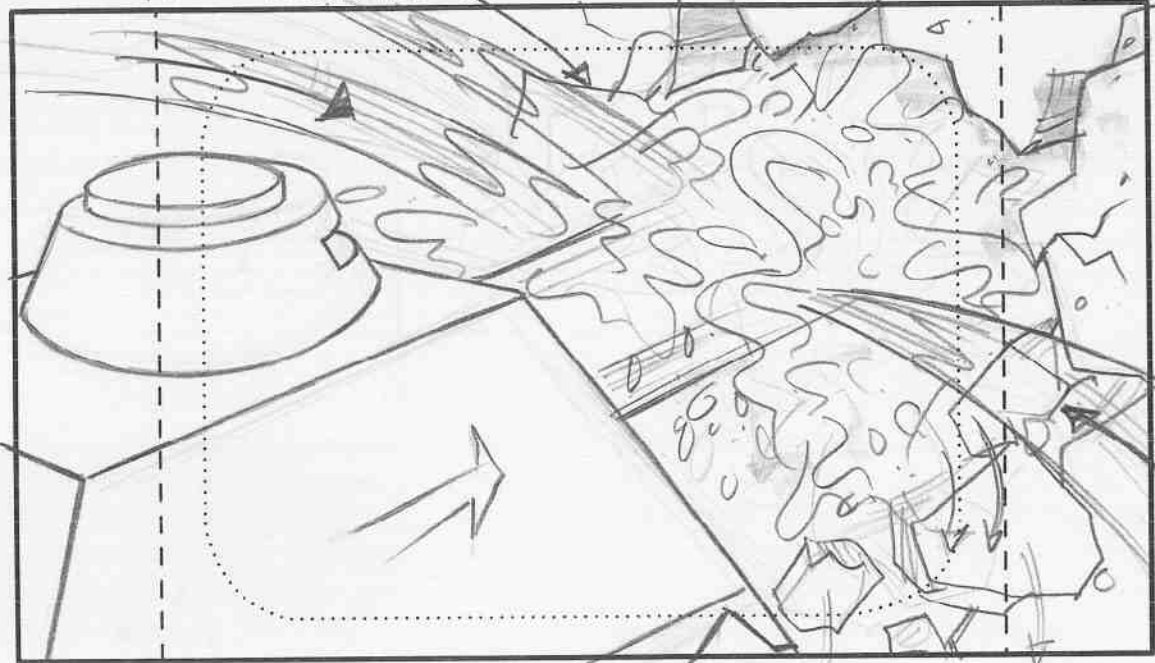

Dialogue Action

CHUNKS BREAK AWAY FROM THE WALL
NOSEY STARTS TO MOVE FORWARD.

EFF: (S/T WATER, BLUR)

SFX: < ROCK BREAKING, WATER SPRAY, DRILLING >

Sc. CONTD

Panel D

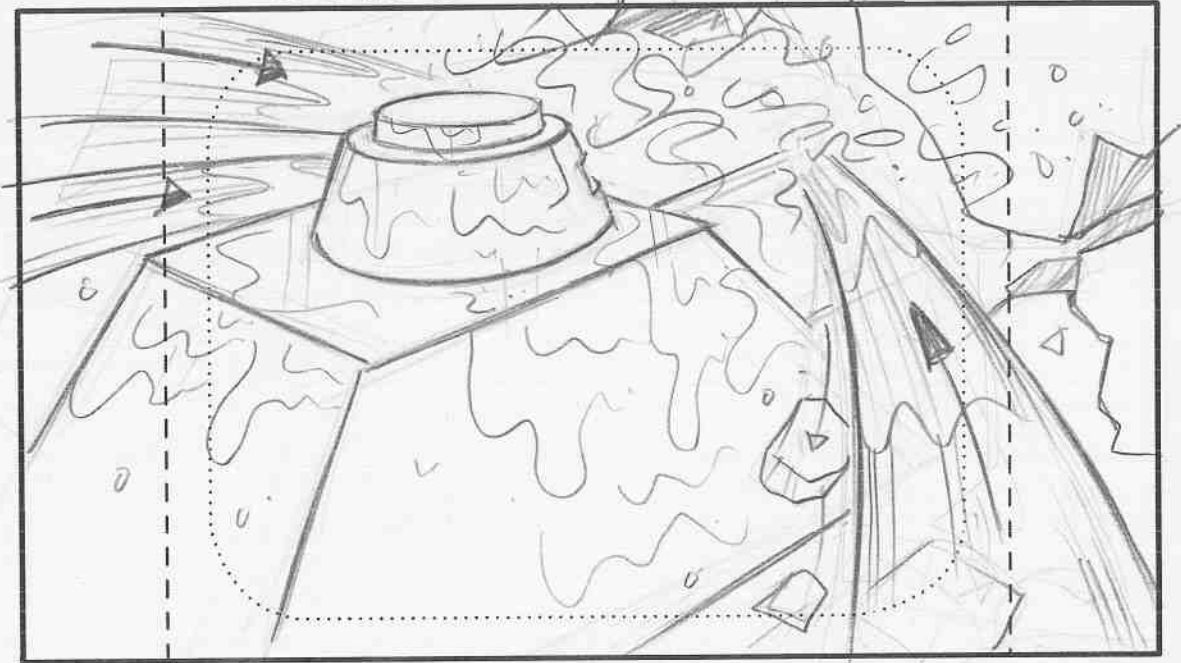

Dialogue Action

NOSEY MOVES FURTHER. THE TRUCKS CONTINUE
TO SPRAY WATER ON NOSEY'S NOSE. LARGER
CHUNKS FALL FREE FROM THE WALL.

CUT

257-777



FIREHOUSE TALES

©2005 Warner Bros. This Material is the PROPERTY OF WARNER BROS. TELEVISION ANIMATION. It is unpublished and must not be taken from the studio, duplicated or used in any manner, except for production purposes, and may not be sold or transferred.

Sc. 72

S/A BG

Panel

(A)

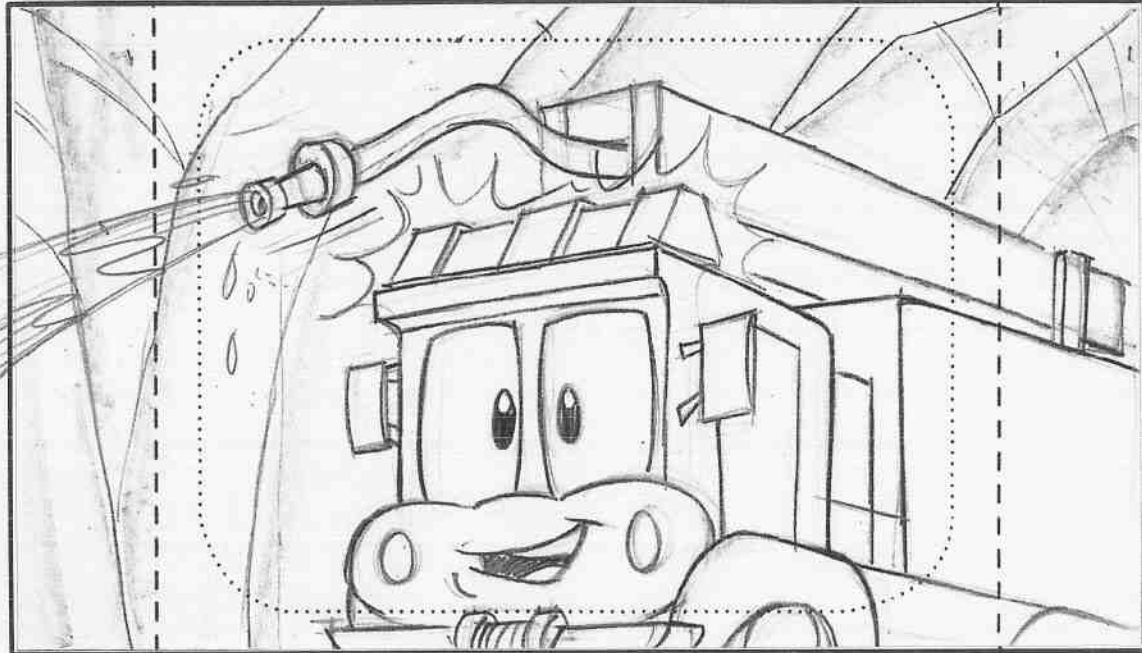

CUT

Dialogue Action

CLOSE ON RED.

EFX: (S/T WATER , BOT. LITE LIGHT)

(61) RED:

WE'RE RIGHT BEHIND YOU!

Sc.

CONTD.

Panel

(B)

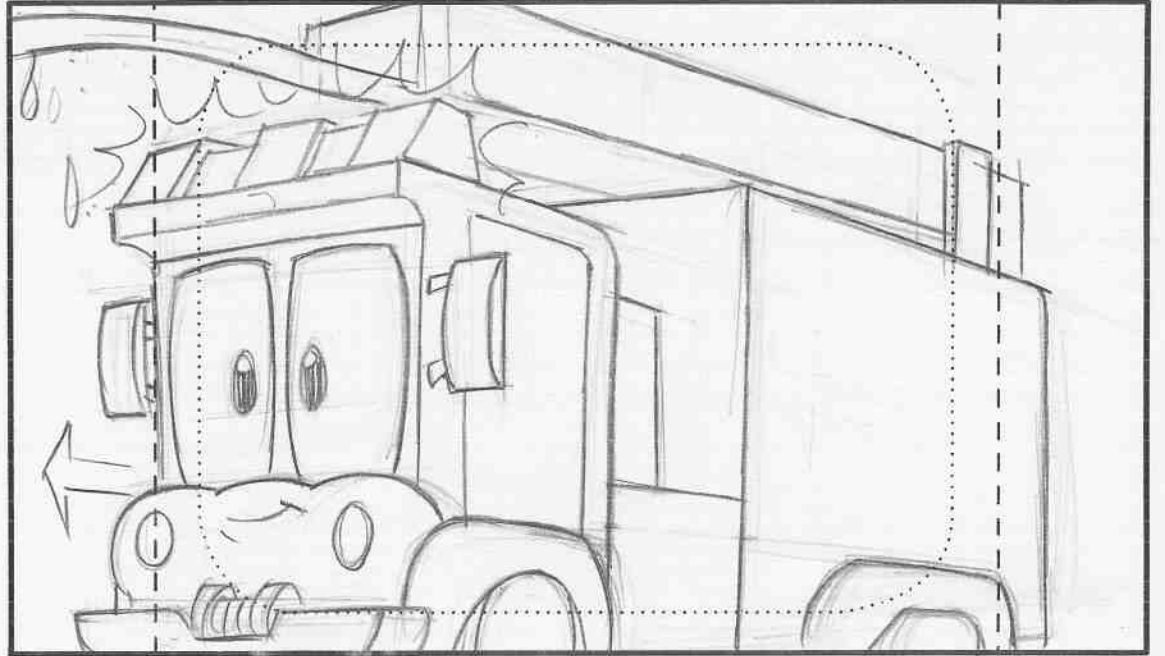

Dialogue Action

RED MOVES FORWARD.

(62) WISER: (VO)

SO WITH LOTS OF WATER AND GOOD AIM...

CUT

257-777



FIREHOUSE TALES

©2005 Warner Bros. This Material is the PROPERTY OF WARNER BROS. TELEVISION ANIMATION. It is unpublished and must not be taken from the studio, duplicated or used in any manner, except for production purposes, and may not be sold or transferred.

Sc. 73

Panel A

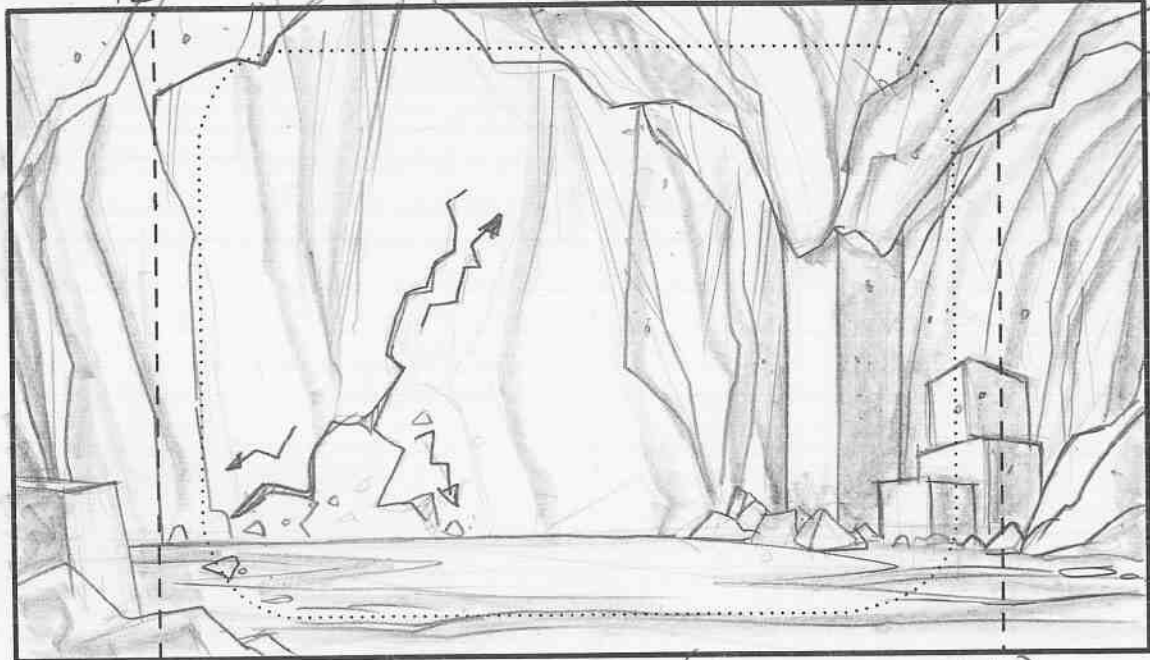

CUT

Action INT. A DIFFERENT CHAMBER - (ANGLE ON WALL)
THE RUMBLING NOISE BUILDS IN INTENSITY. A CRACK APPEARS IN THE WALL

Dialogue SFX: < ROCK DRILLING >
(63) WISER: (VO) (CONTD)
.. THE FIRE TRUCKS HELP NOSEY ...

Sc. CONTD

Panel B

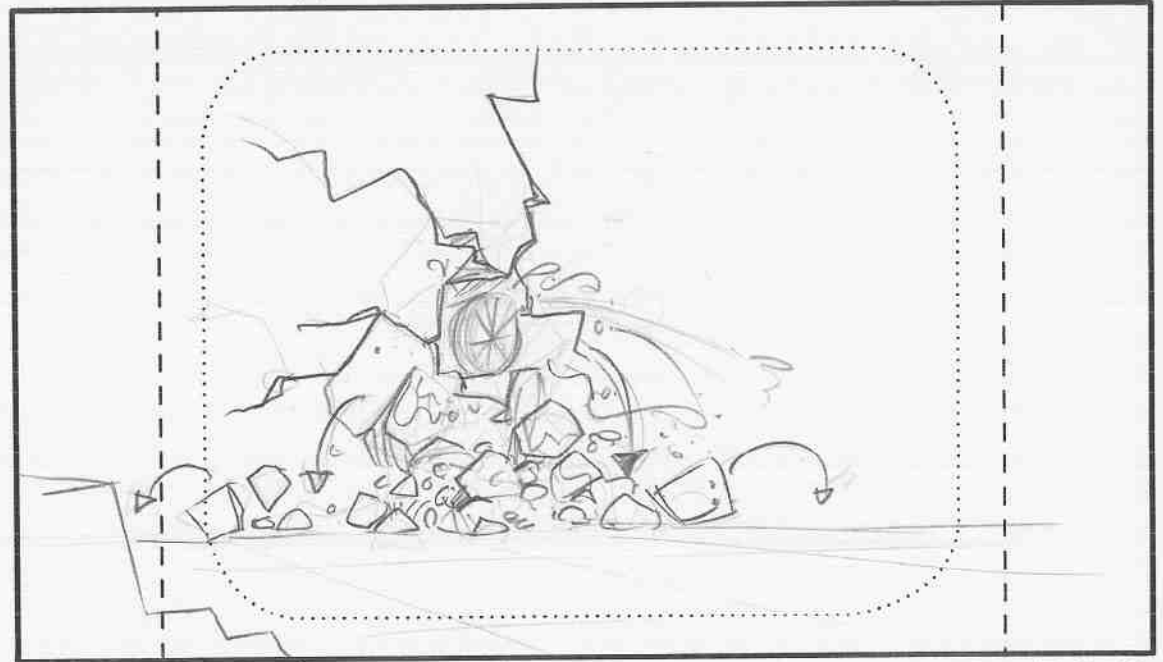

Action NOSEY'S NOSE BREAKS THROUGH. CHUNKS OF ROCK FALL AS NOSEY WIDENS THE HOLE. ROCKS TUMBLE AND WATER GUSHES THROUGH. EFX: (S/T WATER)

Dialogue SFX < ROCK CRUMBLES, DRILL SPIN, WATER SPRAY >
(63) WISER: (VO) (CONTD)
... FINALLY BREAK THROUGH THE ROCK ..

257-777



FIREHOUSE TALES

©2005 Warner Bros. This Material is the PROPERTY OF WARNER BROS. TELEVISION ANIMATION. It is unpublished and must not be taken from the studio, duplicated or used in any manner, except for production purposes, and may not be sold or transferred.

Sc. 73 CONTD

Panel C

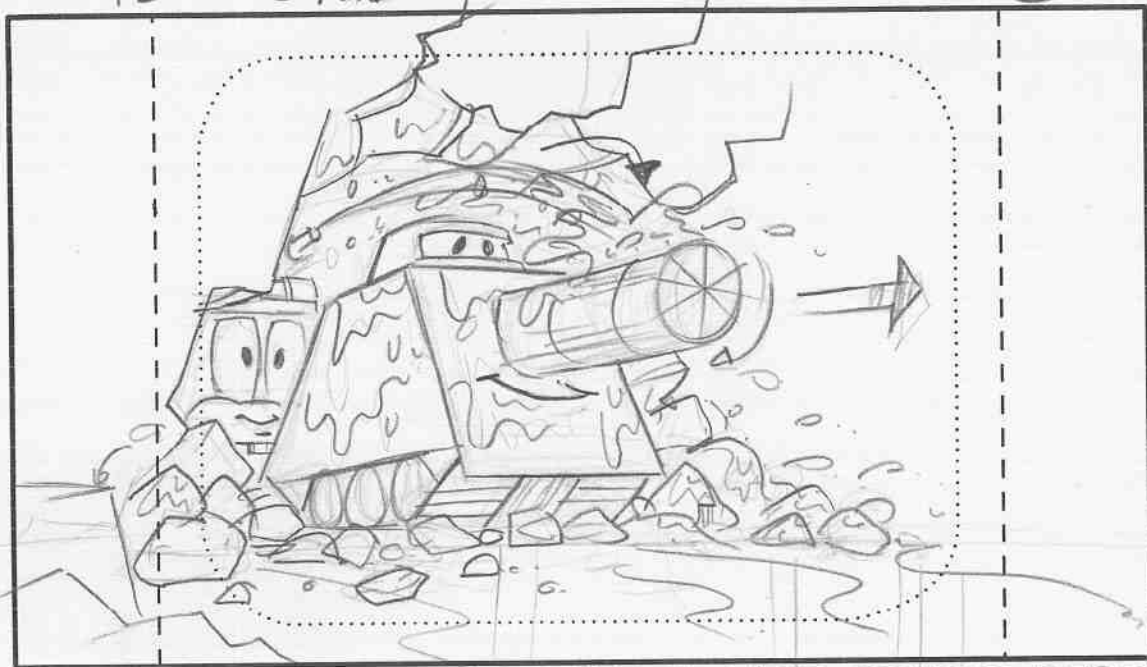

Action NOSEY PUSHES THROUGH THE LAST OF THE DEBRIS. HE'S FOLLOWED BY RED, WHO CONTINUES TO SPRAY WATER.

Dialogue FFX: (BLUR, ST WATER)
SFX: < RUMBLE, WATER SPRAY >

Sc. CONTD

Panel D

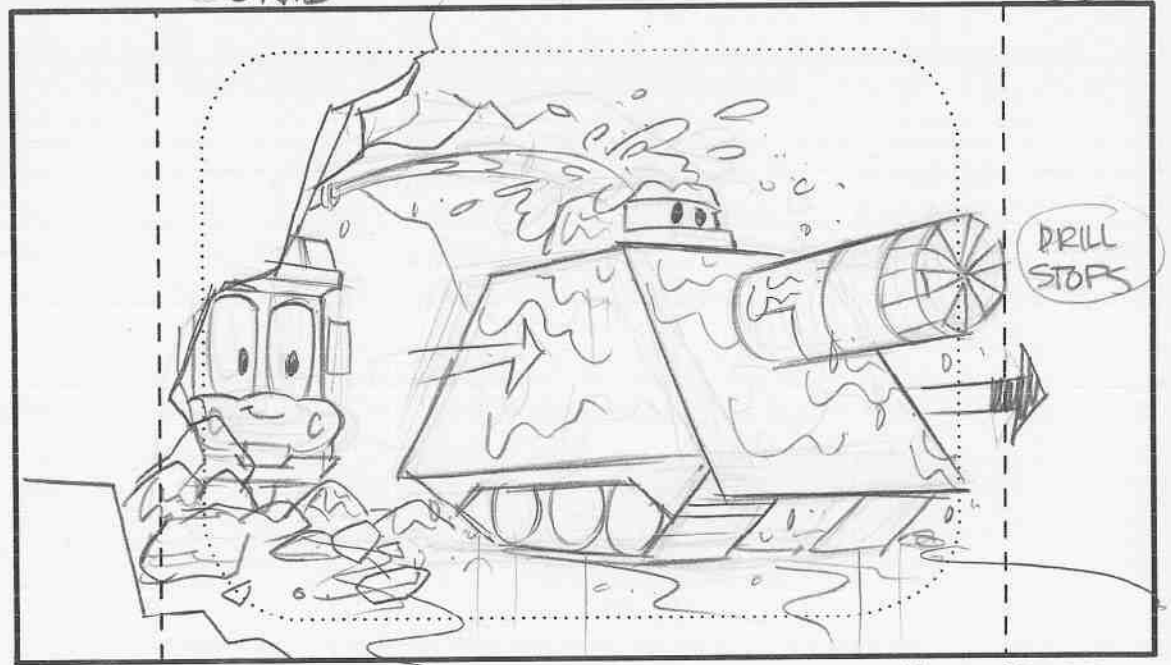

Action NOSEY TRUNDLES FORWARD DRIPPING WITH WATER. HE'S STILL BEING HOSED. HIS NOSE STOPS SPINNING.

CUT

257-777



FIREHOUSE TALES

©2005 Warner Bros. This Material is the PROPERTY OF WARNER BROS. TELEVISION ANIMATION. It is unpublished and must not be taken from the studio, duplicated or used in any manner, except for production purposes, and may not be sold or transferred.

Sc. 74

(N)

Panel

(A)

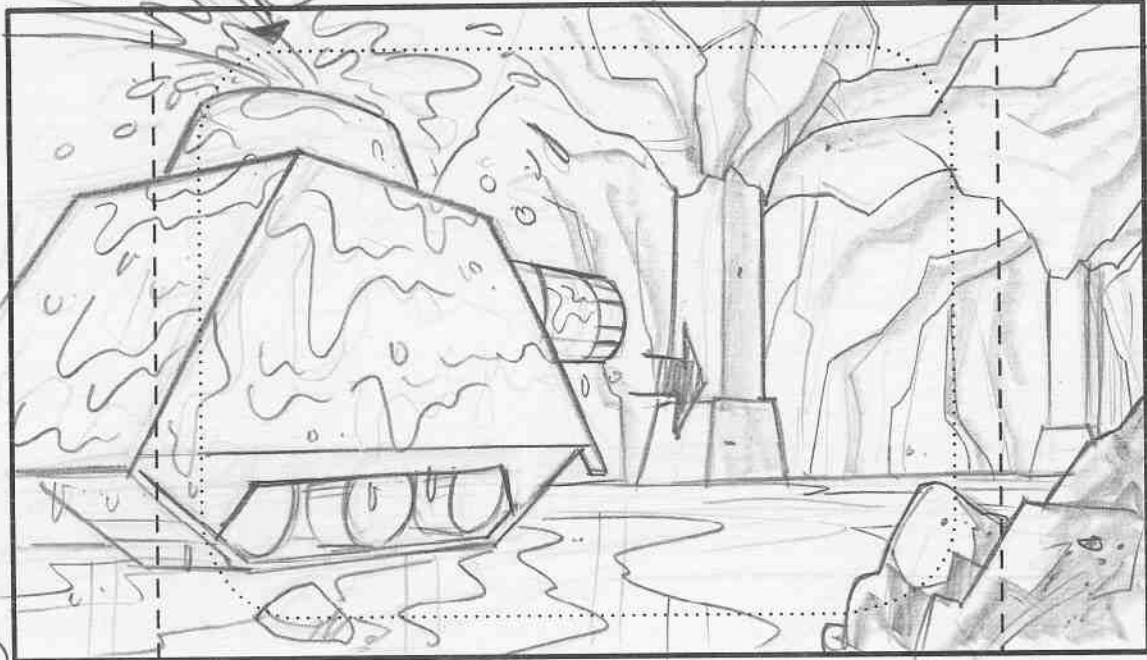

Sc.

CONTD

Panel

(B)

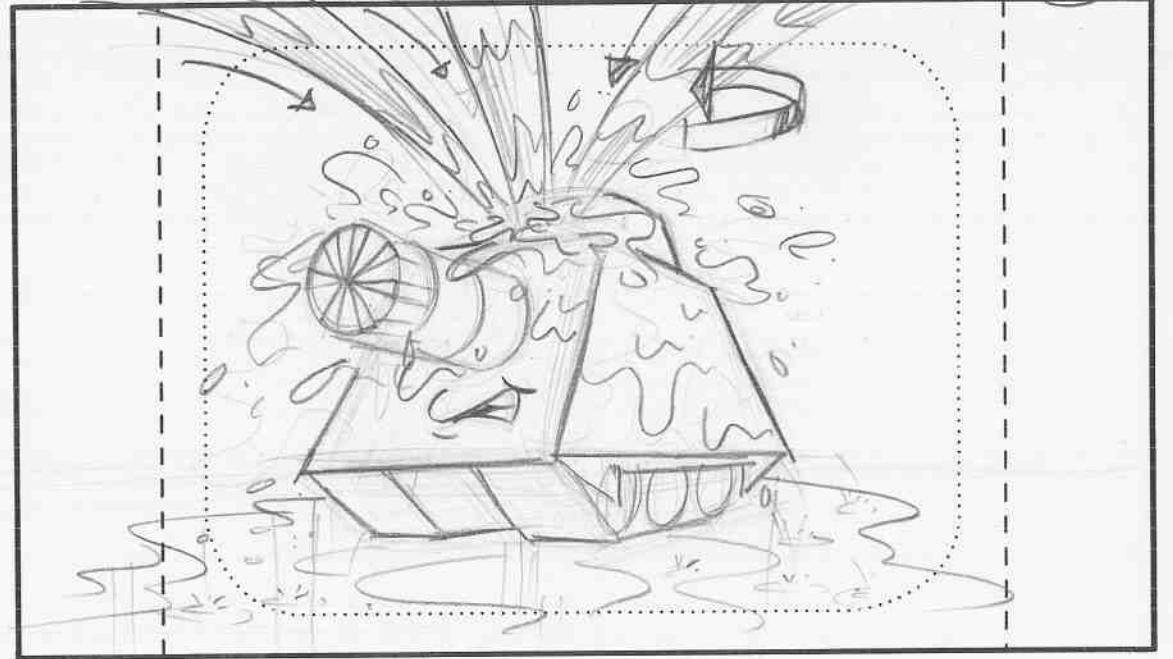

Dialogue Action

ANOTHER ANGLE ON THE CHAMBER. NOSEY TRUNDLES FORWARD. THE TRUCKS ARE STILL SPRAYING HIM

EFFX: (S/T WATER) SFX: <WATER SPRAY, ENGINE>

Dialogue Action

NOSEY TURNS AROUND

(6A) NOSEY: (SPUTTERING)
OKAY, YOU CAN SHUT OFF THE WATER NOW!



FIREHOUSE TALES

©2005 Warner Bros. This Material is the PROPERTY OF WARNER BROS. TELEVISION ANIMATION. It is unpublished and must not be taken from the studio, duplicated or used in any manner, except for production purposes, and may not be sold or transferred.

Sc. 74 CONTD

Panel (C)

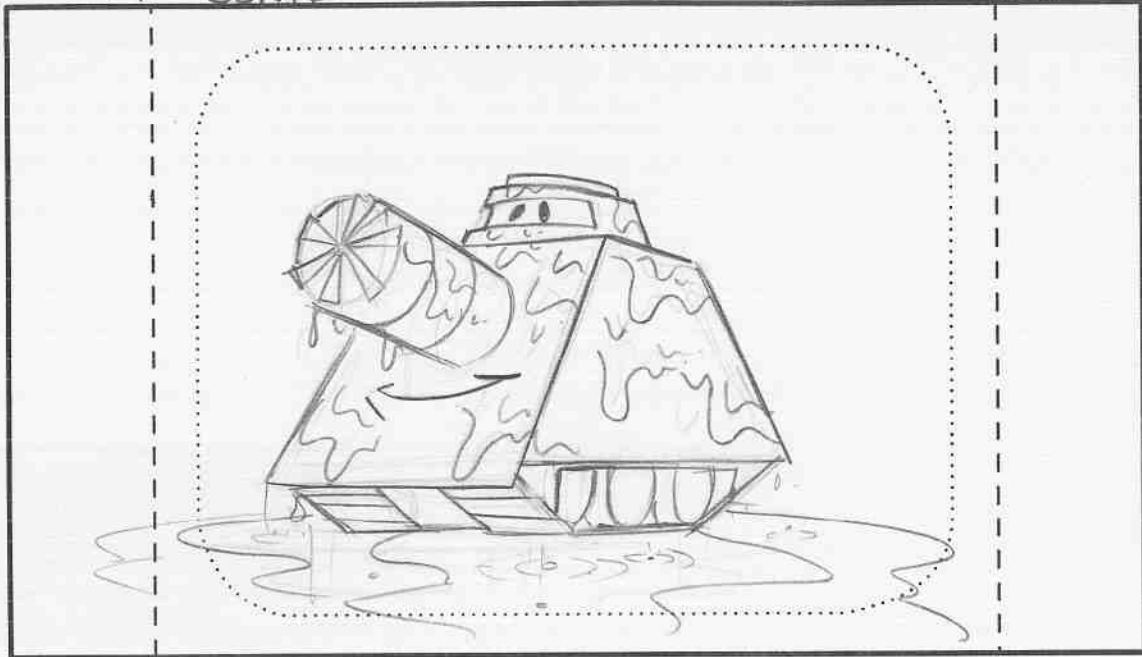

Action THE WATER STOPS AND A DRIPPING NOSEY STANDS IN A LARGE PUDDLE

EFX: (S/T WATER)

SFX: <DRIPS>

Dialogue

(CUT)

Sc. 75

Panel

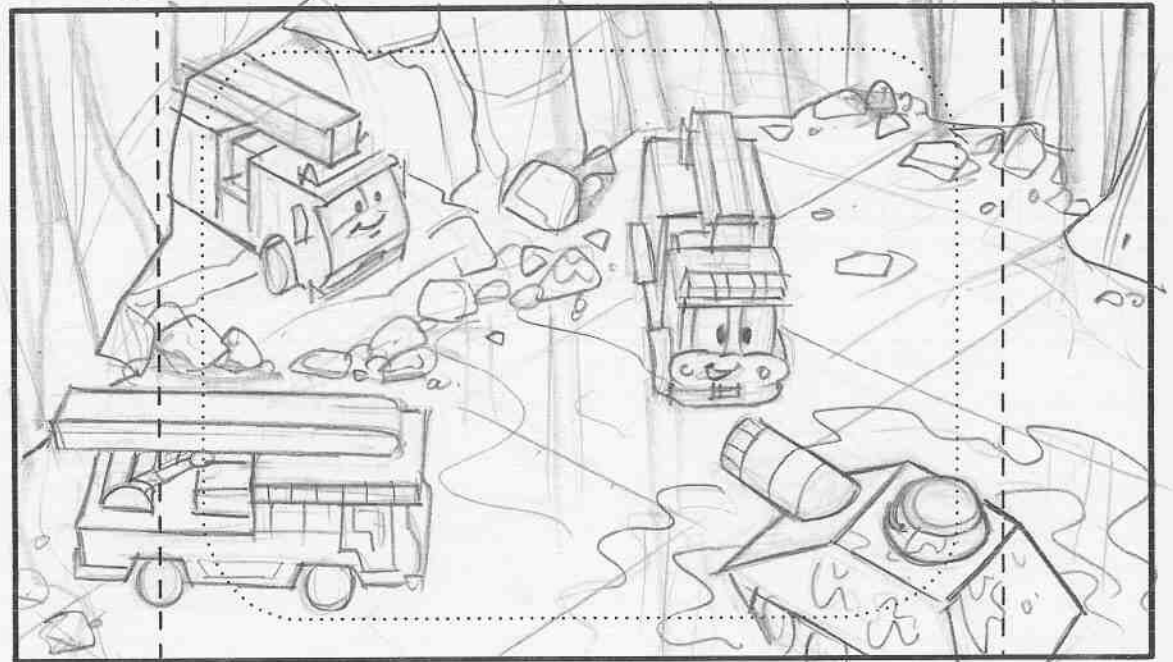

Action WIDE ON THE GROUP.

EFX: (S/T WATER)

(65) RED:

YOU DID IT NOSEY! YOU BROKE THROUGH!

Dialogue

(CUT)



FIREHOUSE TALES

©2005 Warner Bros. This Material is the PROPERTY OF WARNER BROS. TELEVISION ANIMATION. It is unpublished and must not be taken from the studio, duplicated or used in any manner, except for production purposes, and may not be sold or transferred.

Sc. 76

Panel A

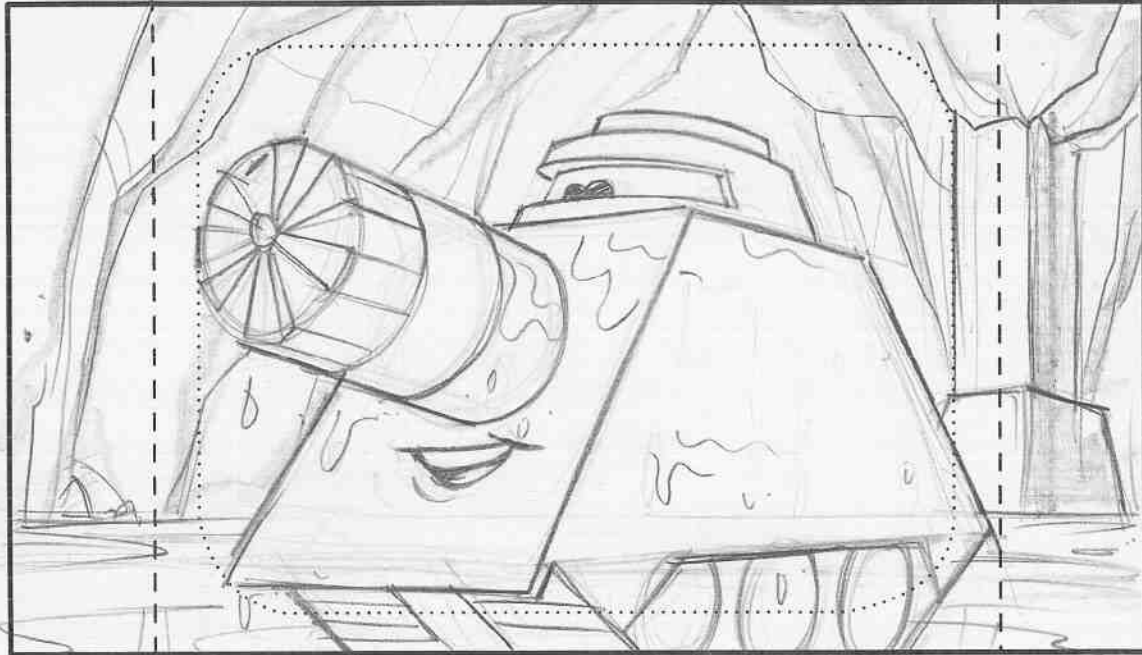

CUT

Dialogue Action

CLOSE ON NOSEY LOOKING CROSS-EYED AT HIS NOSE.

EFF (S/T DRIPS)

(66) NOSEY:

AND MY NOSE NEVER EVEN GOT WARM!

Sc.

CONTD

Panel B

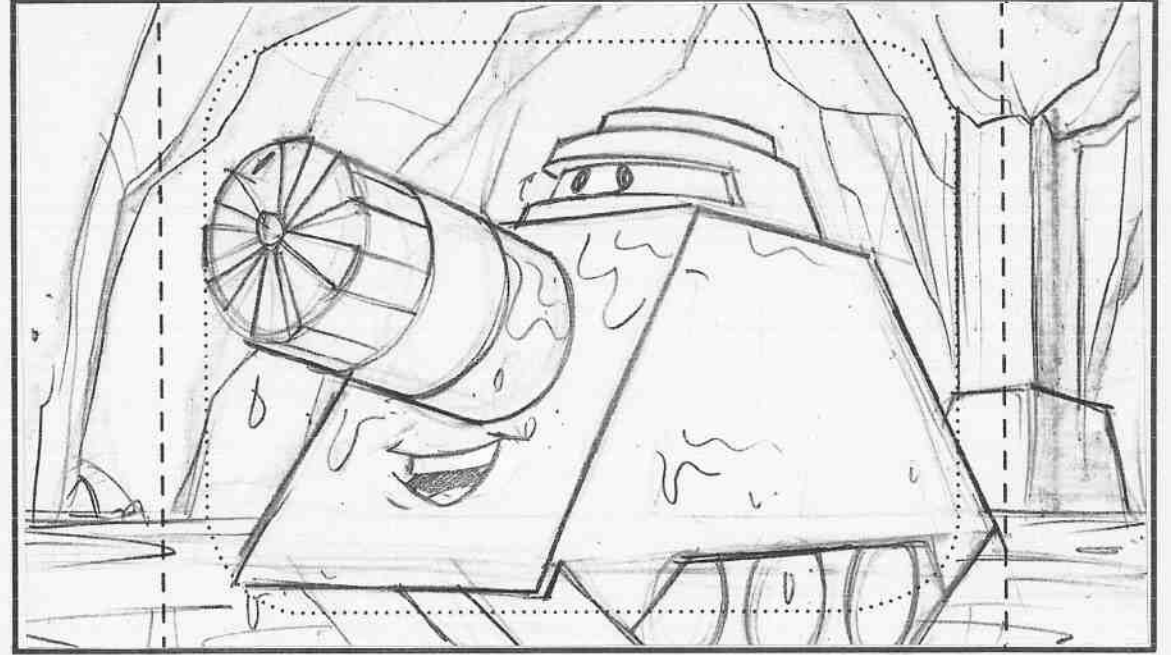

Dialogue Action

NOSEY LOOKS BACK UP AT THE OS FIRETRUCKS.

(66) NOSEY: (CONTD)

BUT THE BEST NEWS IS I WON'T HAVE TO DRILL AT NIGHT ANYMORE.

CUT

257-777



FIREHOUSE TALES

©2005 Warner Bros. This Material is the PROPERTY OF WARNER BROS. TELEVISION ANIMATION. It is unpublished and must not be taken from the studio, duplicated or used in any manner, except for production purposes, and may not be sold or transferred.

Sc. 77

Panel

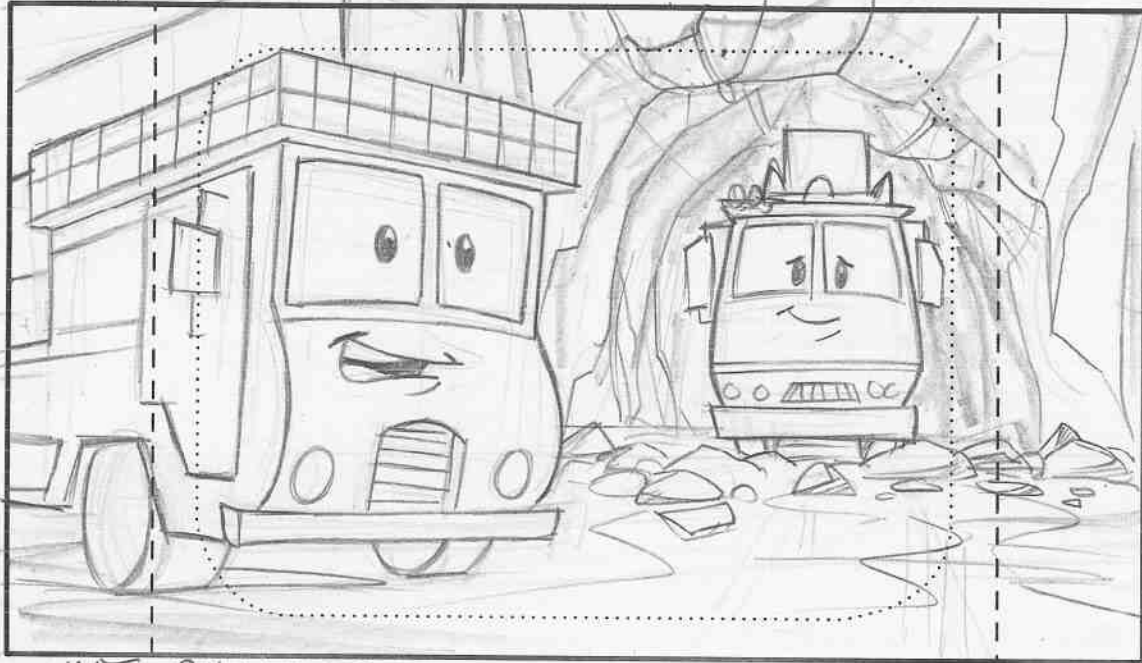

CUT

Dialogue Action

INT. CHAMBER
ANGLE ON PETROL AND CRABBY.

(67) PETROL:
FINALLY, SOME PEACE AND QUIET!

Dialogue Action

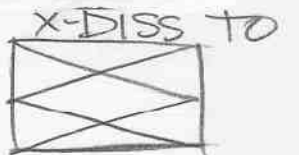

257-777



FIREHOUSE TALES

©2005 Warner Bros. This Material is the PROPERTY OF WARNER BROS. TELEVISION ANIMATION. It is unpublished and must not be taken from the studio, duplicated or used in any manner, except for production purposes, and may not be sold or transferred.

Sc. 78

SABG1 Panel

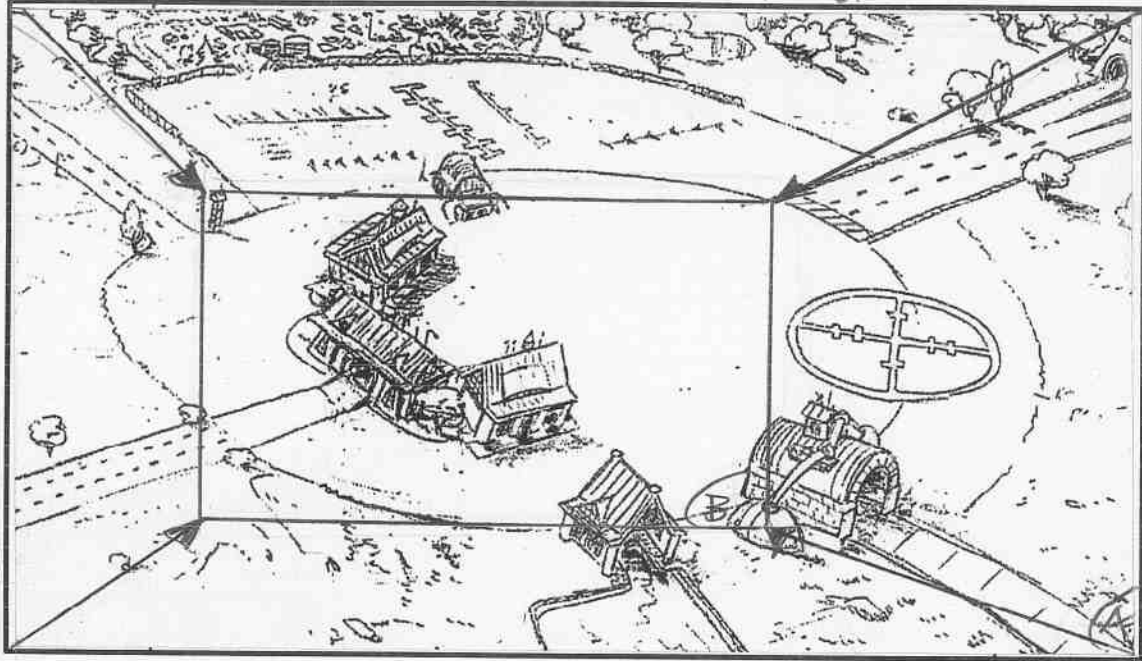

X-DISS FROM

Dialogue Action

EXT. FIREHOUSE (NIGHT)

OVER THE NIGHT NOISES WE CAN HEAR CRABBY SNORING

TRUCK IN (A) → (B)

CUT

(68) WISER: (VO) (CHUCKLING)
WELL, ALMOST...

(69) CRABBY: (ON B-TRK) <SNORING>

Sc.

Panel

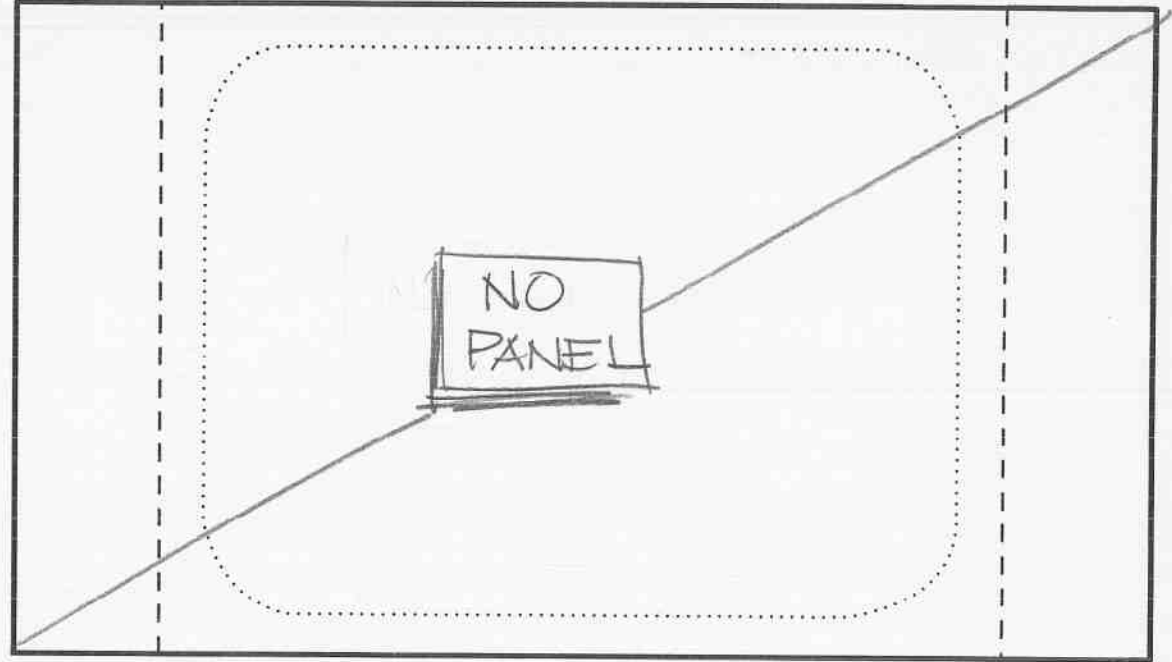

Dialogue Action

257-777



FIREHOUSE TALES

©2005 Warner Bros. This Material is the PROPERTY OF WARNER BROS. TELEVISION ANIMATION. It is unpublished and must not be taken from the studio, duplicated or used in any manner, except for production purposes, and may not be sold or transferred.

Sc. 79

S/ABG 2 Panel

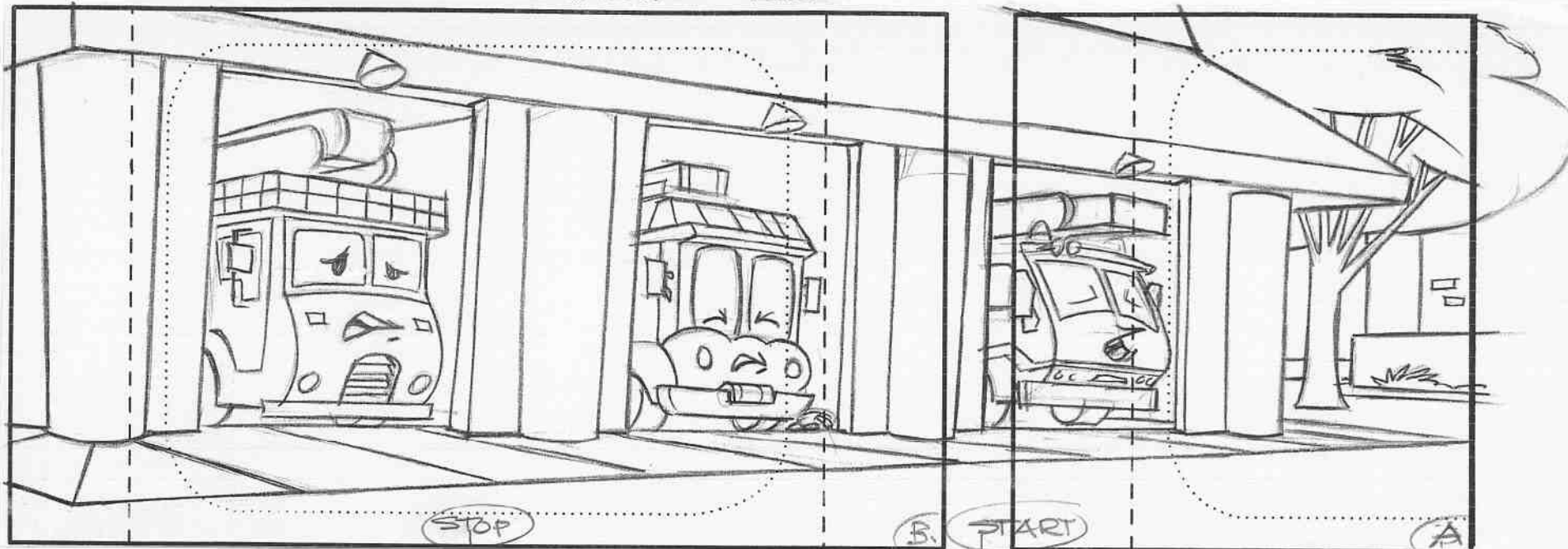

CUT **Action** EXT. JUNIOR GARAGE (NIGHT) ← PAN
 CRABBY IS SNORING EVEN MORE LOUDLY THAN THE NIGHT BEFORE. PAN (A) → (B)

Action PETROL AND RED DON'T LOOK VERY HAPPY.

Dialogue (70) PETROL: "BUST ME BLINKERS, WHAT ARE WE GOING TO DO?"
 (69) CRABBY: (ON 'B'-TRK) (SNORING CONTD)

Dialogue

CUT

257-777



FIREHOUSE TALES

©2005 Warner Bros. This Material is the PROPERTY OF WARNER BROS. TELEVISION ANIMATION. It is unpublished and must not be taken from the studio, duplicated or used in any manner, except for production purposes, and may not be sold or transferred.

Sc. 80

S/A BG 4 Panel (A)

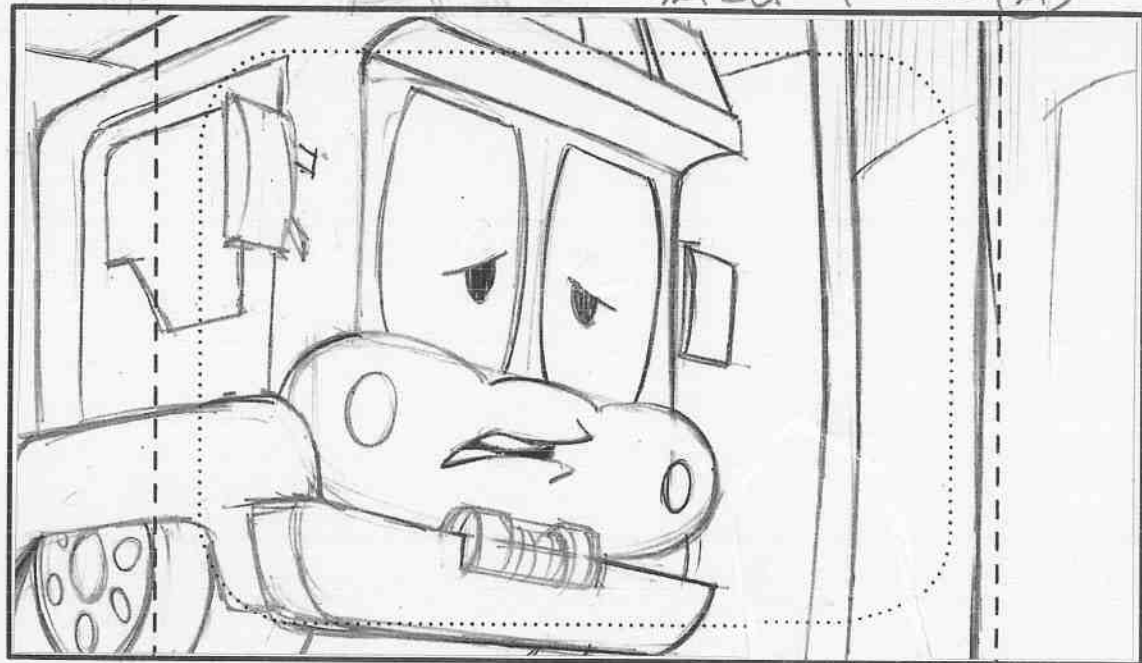

CUT

Dialogue Action

CLOSER ON AN EXHAUSTED RED.

(71) RED:

I KNOW!

(69) CRABBY: (ON 'B' TRK) (SNORING)

Sc. CONTD

Panel (B)

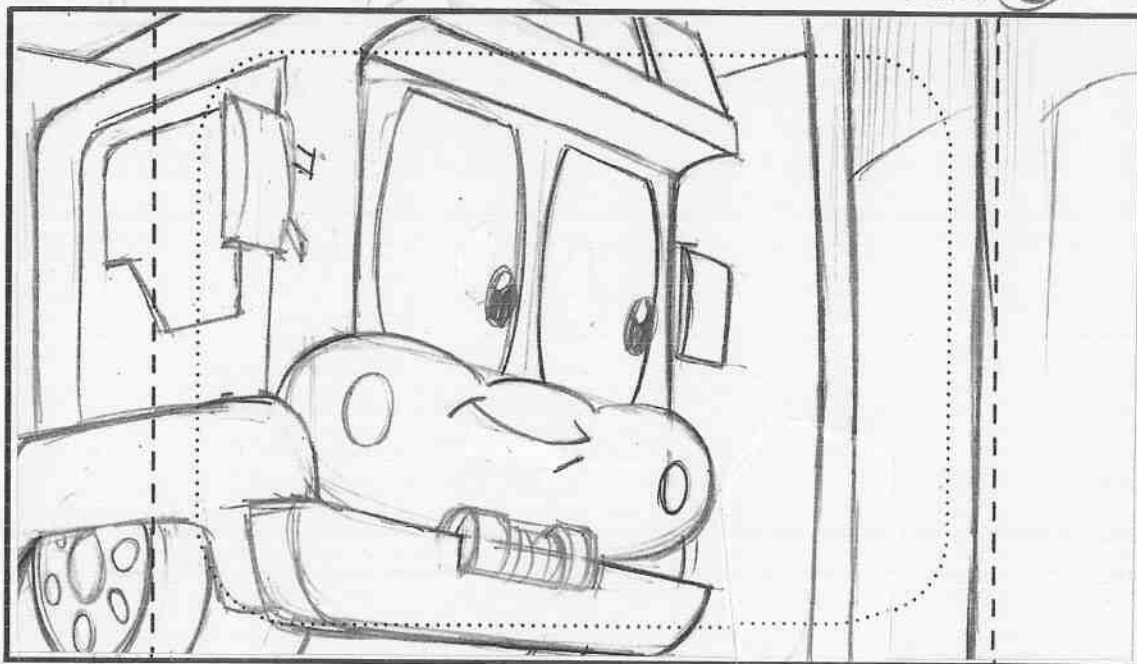

Dialogue Action

SUDDENLY RED NOTICES SOMETHING OS.

257-777



FIREHOUSE TALES

©2005 Warner Bros. This Material is the PROPERTY OF WARNER BROS. TELEVISION ANIMATION. It is unpublished and must not be taken from the studio, duplicated or used in any manner, except for production purposes, and may not be sold or transferred.

Sc. 81

Panel A

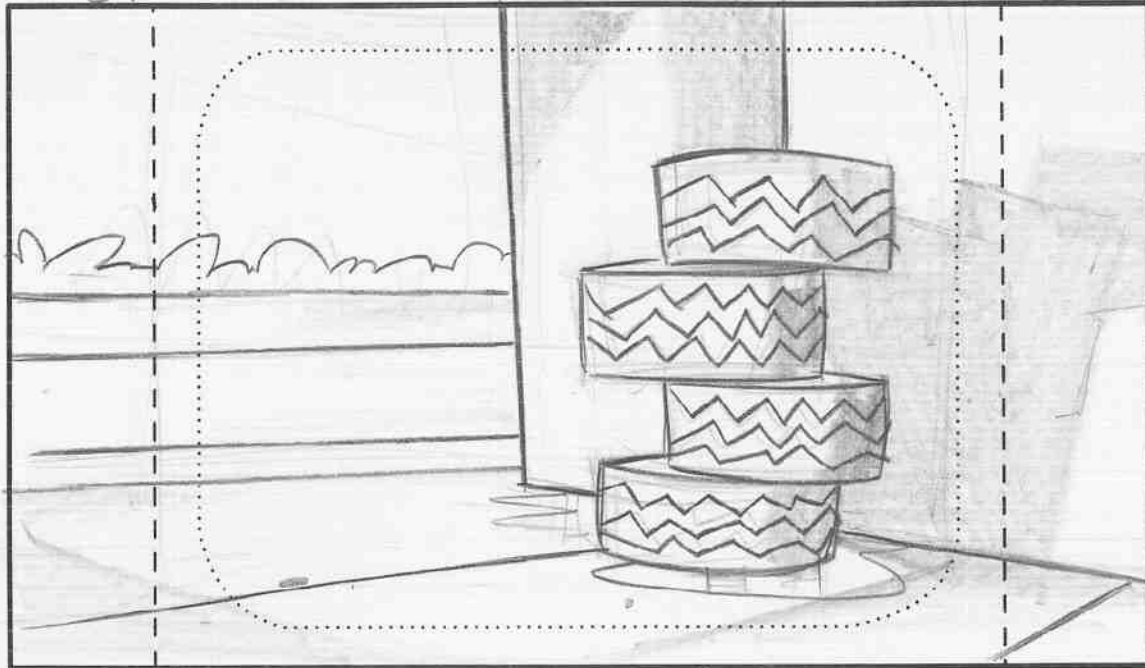

UT

Action ANGLE ON FOUR GIANT TIRES STACKED UP AGAINST A WALL.

Dialogue (9) CRABBY: (ON 'B' TRK.) (OS)
(SNORING)

Sc. CONTD.

Panel B

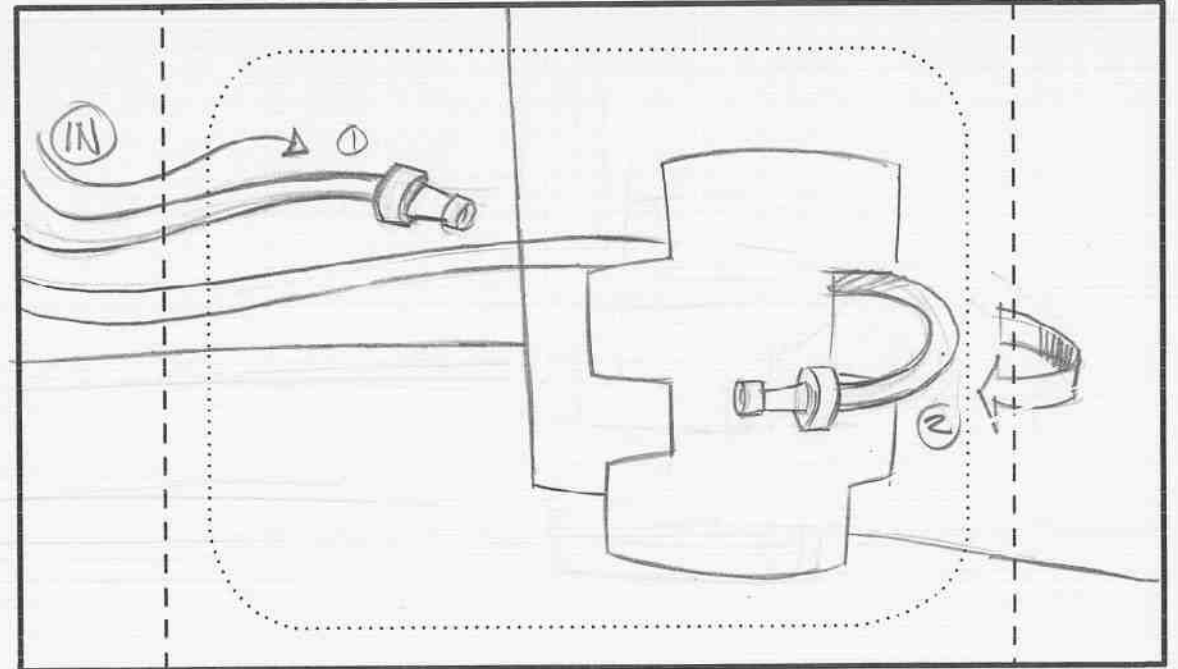

Action RED'S HOSE SNAKES IN AND AROUND THE TIRE STACK.

Dialogue

257-777



FIREHOUSE TALES

©2005 Warner Bros. This Material is the PROPERTY OF WARNER BROS. TELEVISION ANIMATION. It is unpublished and must not be taken from the studio, duplicated or used in any manner, except for production purposes, and may not be sold or transferred.

Sc.

CONT'D

Panel

(C)



Dialogue Action

THE STACK IS YANKED OUT

(CUT)

(69) CRABBY: (OS) (CONT'D)
(SNORING)

Sc. 82

Panel

(A)

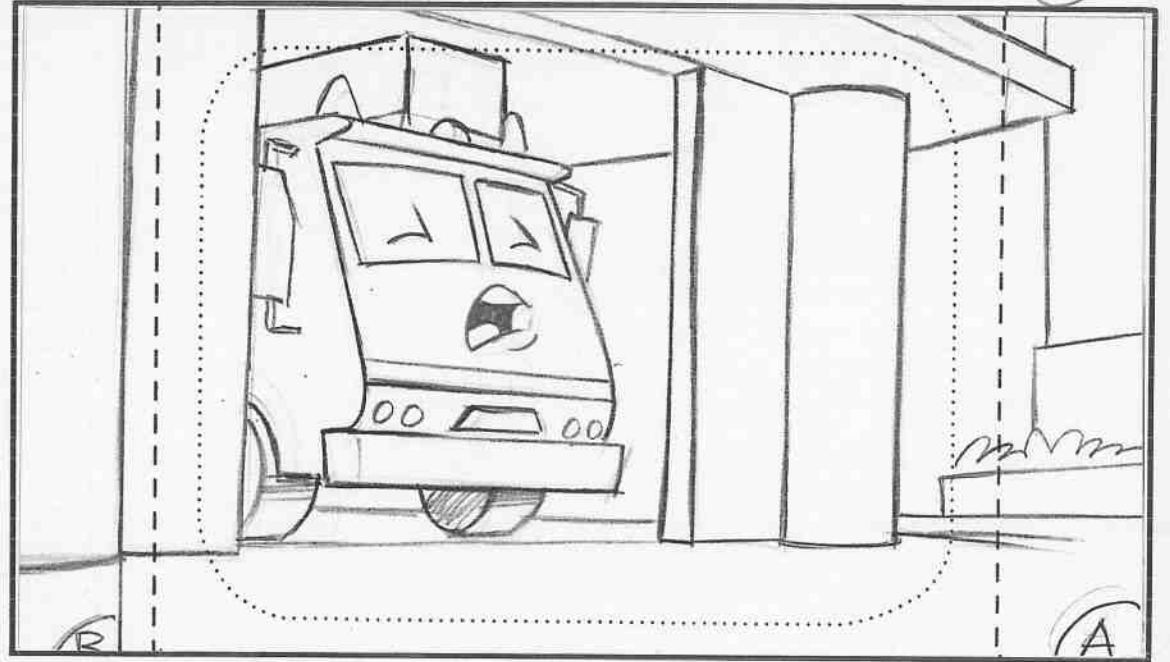

Dialogue Action

ANGLE ON CRABBY SNORING AWAY

(69) CRABBY: (CONT'D)
(SNORING)



FIREHOUSE TALES

©2005 Warner Bros. This Material is the PROPERTY OF WARNER BROS. TELEVISION ANIMATION. It is unpublished and must not be taken from the studio, duplicated or used in any manner, except for production purposes, and may not be sold or transferred.

PNL B

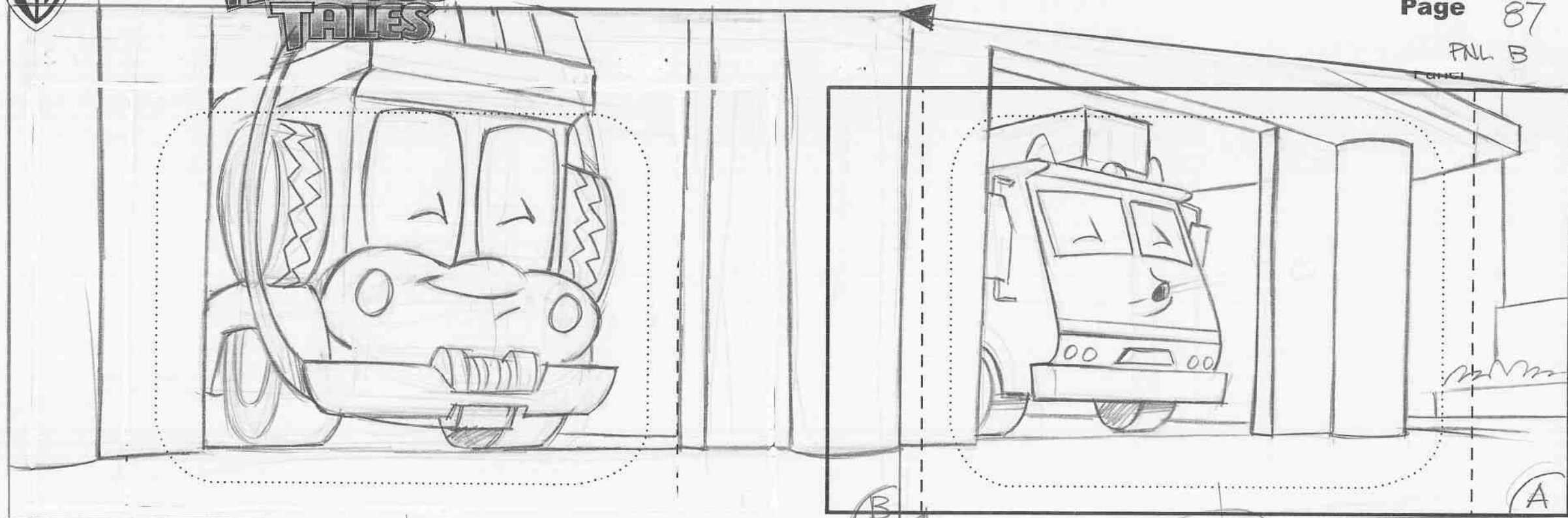

Dialogue Action

PAN & TRUCK OUT (A) → (B)

STOP ← PAN

FAN OVER TO RED
HE'S NOW WEARING
THE TIRES LIKE
EAR MUFFS. THEY'RE
TIED WITH HIS HOSE.

Dialogue Action

START

(A) CRABBY:(CONTD) (SNORING)

257-777



FIREHOUSE TALES

©2005 Warner Bros. This Material is the PROPERTY OF WARNER BROS. TELEVISION ANIMATION. It is unpublished and must not be taken from the studio, duplicated or used in any manner, except for production purposes, and may not be sold or transferred.

Sc. 83 CONTD.

Panel

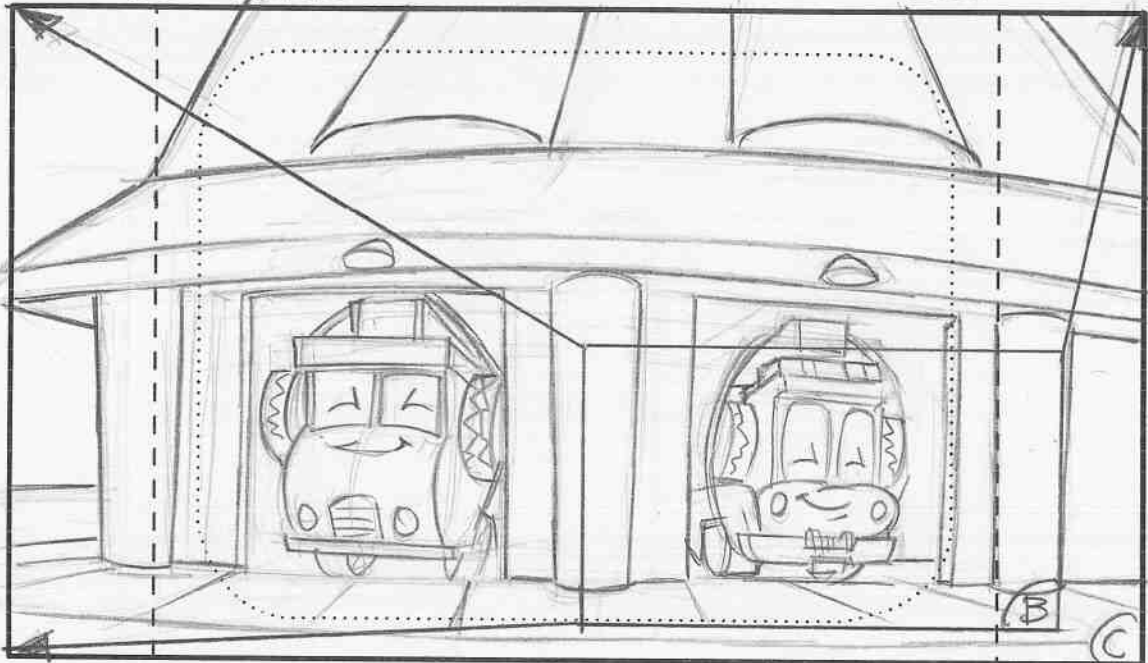

Dialogue Action

CONT TRUCK OUT (B) → (C)
 PETROL ALSO HAS TIRES WRAPPED OVER HIS "EARS." (X-DISS DURING TRUCK OUT)

(71A) RED & PETROL:
 (SATISFIED SIGH)

[AU]
 X-DISS

Sc. 84

Panel (A)

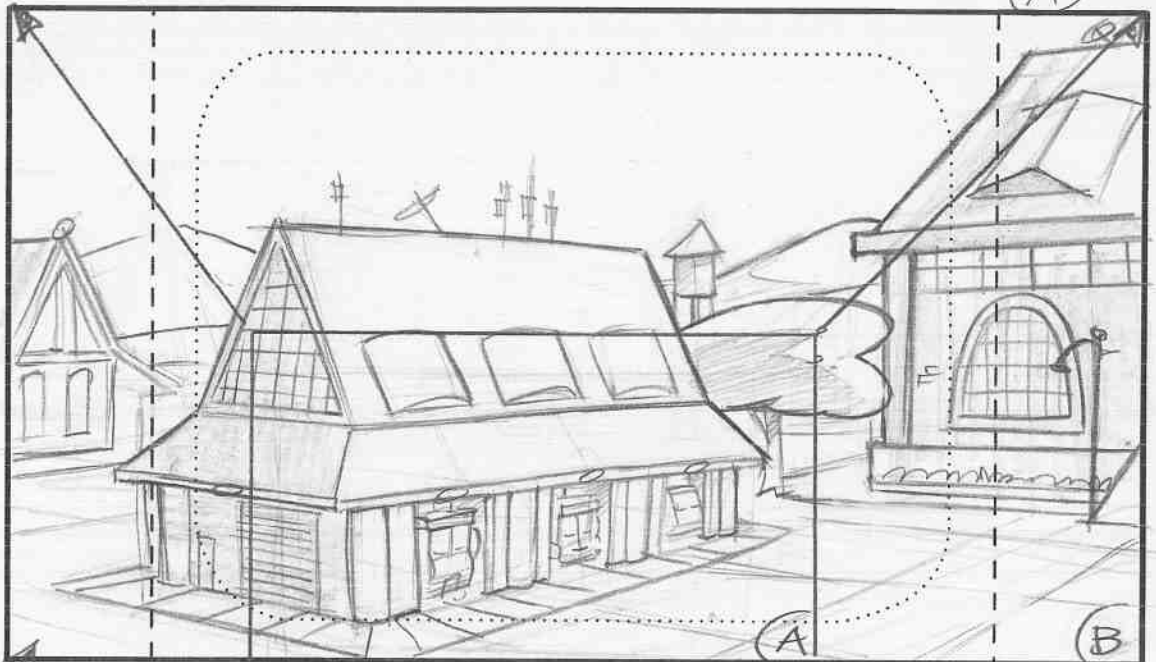

Dialogue Action

EXT. JUNIOR DORMITORY - NIGHT
 TRUCK OUT (A) → (B)
 CONT. CRABBY'S SNORING

(71B) RED/PETROL:
 (SNORING)

(72) WISER: (VO)
 AND THAT'S HOW THE FIRE TRUCKS FINALLY...

257-777



FIREHOUSE TALES

©2005 Warner Bros. This Material is the PROPERTY OF WARNER BROS. TELEVISION ANIMATION. It is unpublished and must not be taken from the studio, duplicated or used in any manner, except for production purposes, and may not be sold or transferred.

Sc. 84 CONTD

Panel B

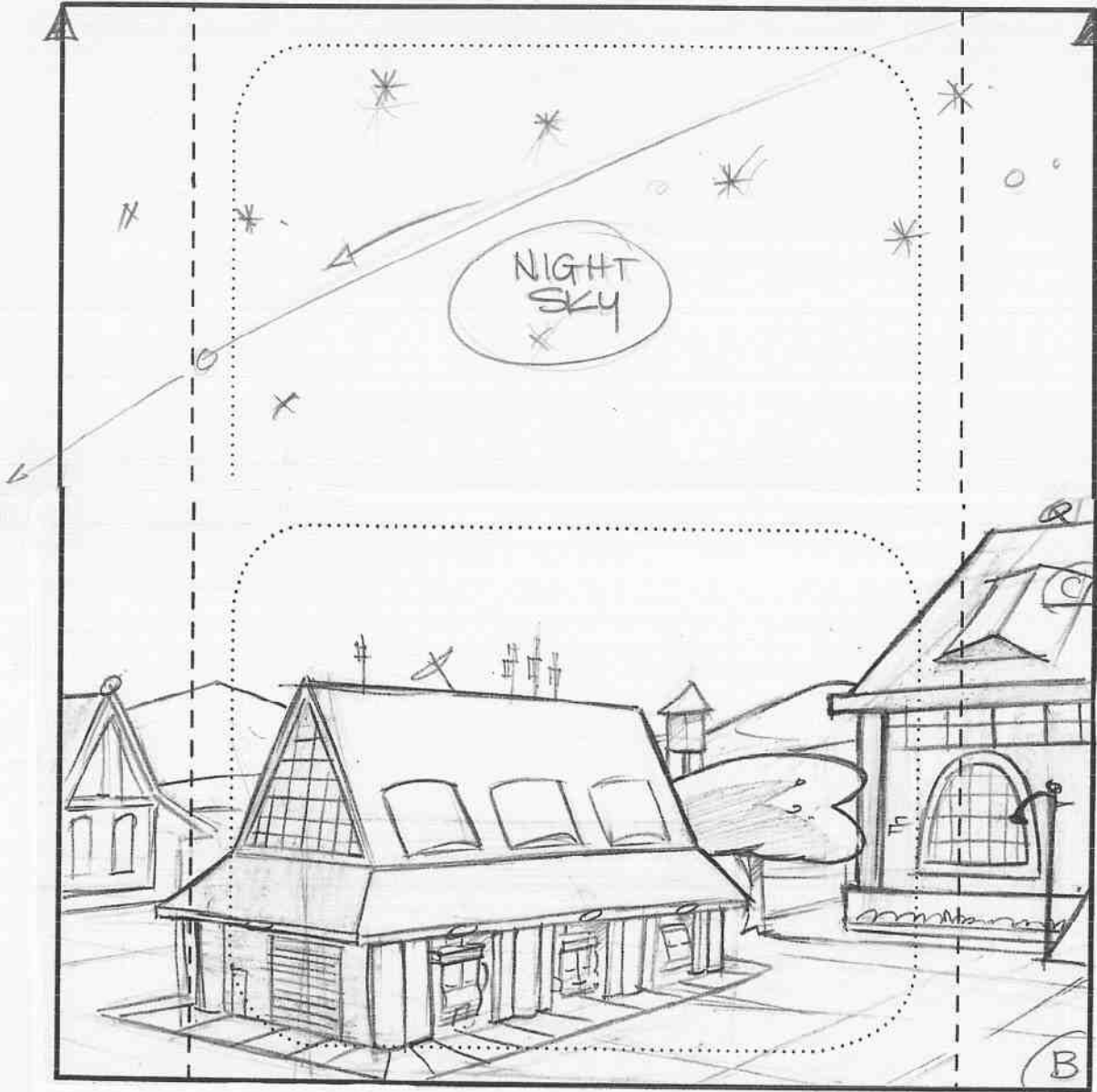

Sc.

Panel

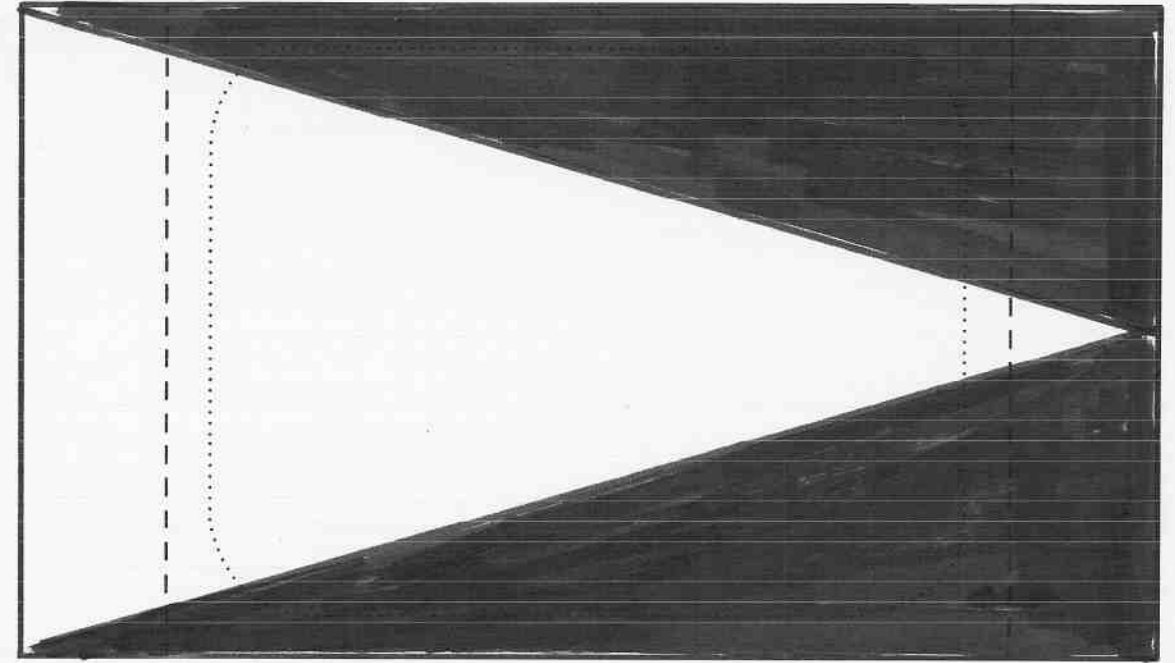

Dialogue Action

PAN (B) -> DC A SHOOTING STAR ZOOMS PAST FADE TO BLACK

(SNOORING CONTINUES)

(72) WISER: (VO) (CONTD)

.. GOT A PEACEFUL NIGHTS SLEEP. (YAWN), GOODNIGHT.

257-777