



**FHT257-786 'SAIL AWAY'**



# FIREHOUSE TALES

©2005 Warner Bros. This Material is the PROPERTY OF WARNER BROS. TELEVISION ANIMATION. It is unpublished and must not be taken from the studio, duplicated or used in any manner, except for production purposes, and may not be sold or transferred.

Page |

Sc.

Panel

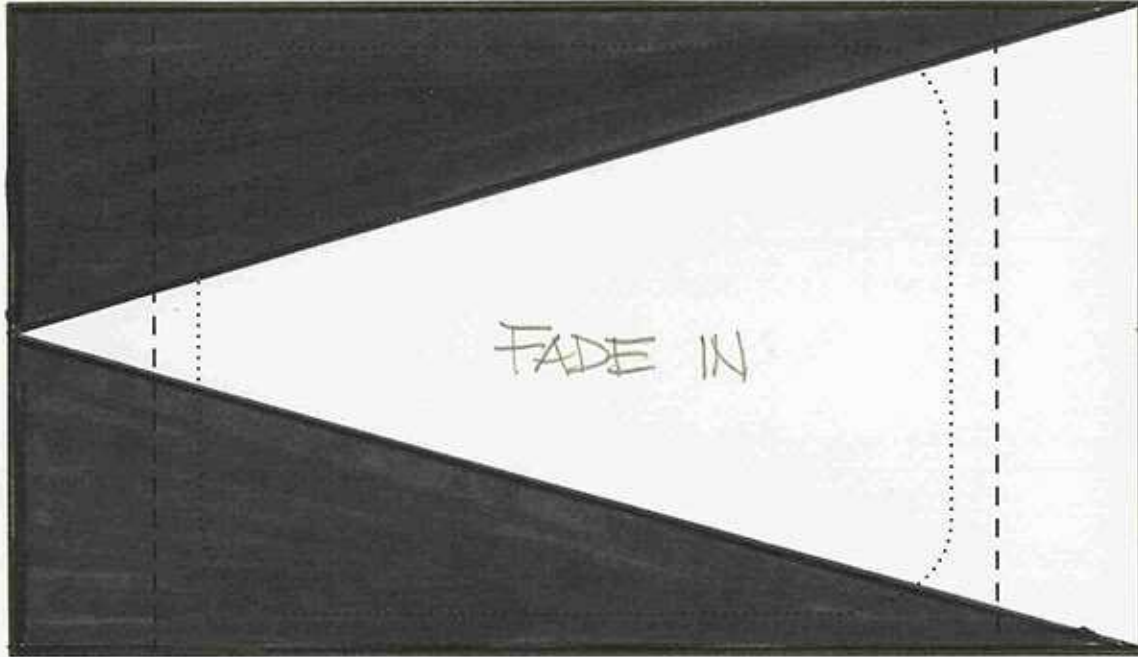

Dialogue Action

Three horizontal lines for dialogue and action.

Sc. |

Panel

(A)

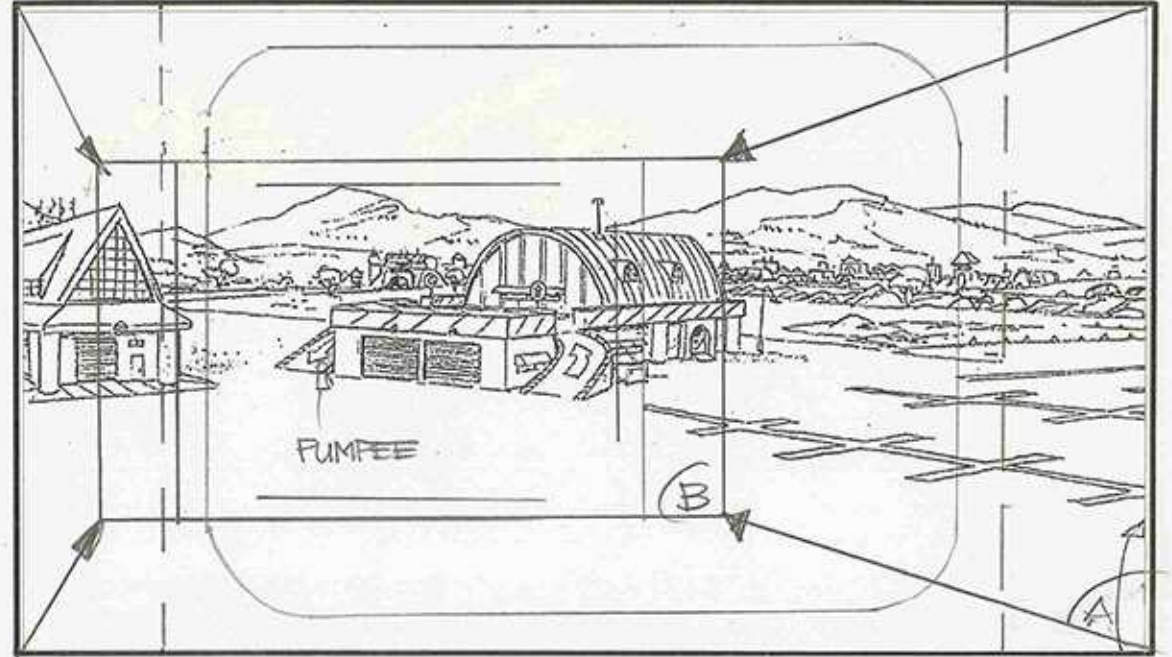

Dialogue Action

EXT. FIREHOUSE GARAGE AREA - (DAY)  
ANGLE ON TECH'S GARAGE.  
TRUCK IN ON GARAGE. AN EXCITED PUMPEE LOOKS AROUND

CUT

① WISER: (VO)

ON THE FIRST MONDAY OF EVERY MONTH,  
THERE ARE TWO THINGS YOU CAN COUNT ON...

Three horizontal lines for dialogue and action.

257-786





# FIREHOUSE TALES

©2005 Warner Bros. This Material is the PROPERTY OF WARNER BROS. TELEVISION ANIMATION. It is unpublished and must not be taken from the studio, duplicated or used in any manner, except for production purposes, and may not be sold or transferred.

Sc. 2

Panel A

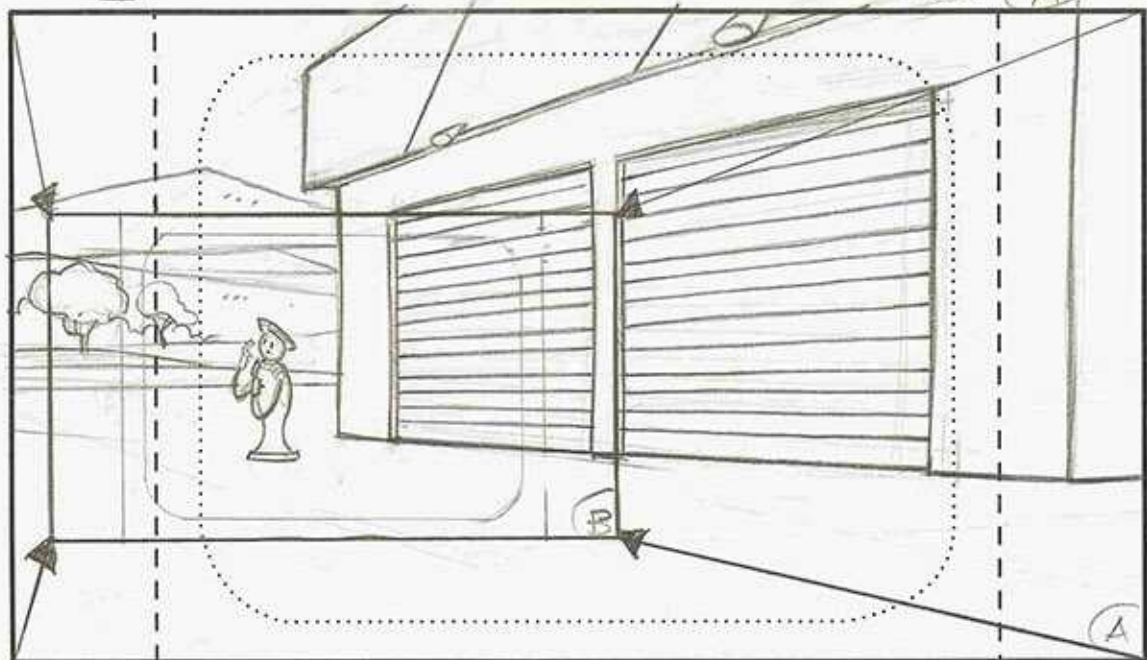

CUT

**Action** EXT. GARAGE AREA - (CONTINUOUS)  
ANGLE ON PUMPEE LOOKING AROUND.  
TRUCK IN (A) → (B)

**Dialogue** ① WISER : (VO) (CONTD)  
.. THAT TANK THE GAS TRUCK WILL BE ROLLING INTO TOWN ...

Sc. CONTD

Panel B

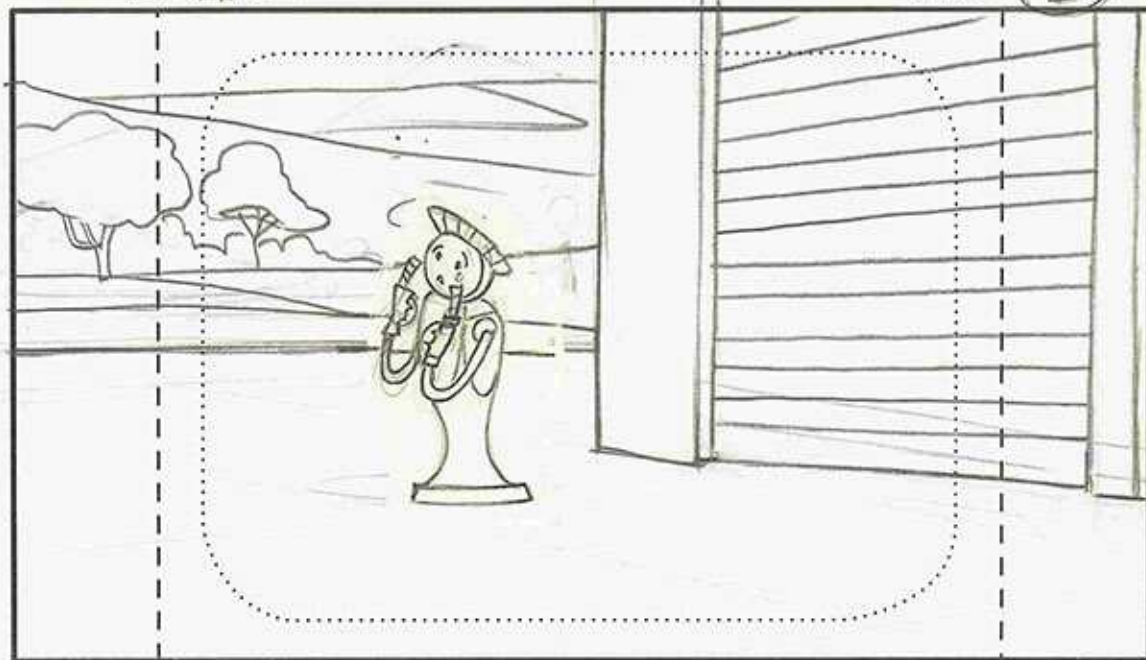

**Action** PUMPEE LOOKS LEFT: ...

**Dialogue** ① WISER : (VO) (CONTD)  
.. AND THAT PUMPEE THE GAS PUMP WILL BE ..



# FIREHOUSE TALES

©2005 Warner Bros. This Material is the PROPERTY OF WARNER BROS. TELEVISION ANIMATION. It is unpublished and must not be taken from the studio, duplicated or used in any manner, except for production purposes, and may not be sold or transferred.

Sc. 2 CONTD

Panel C

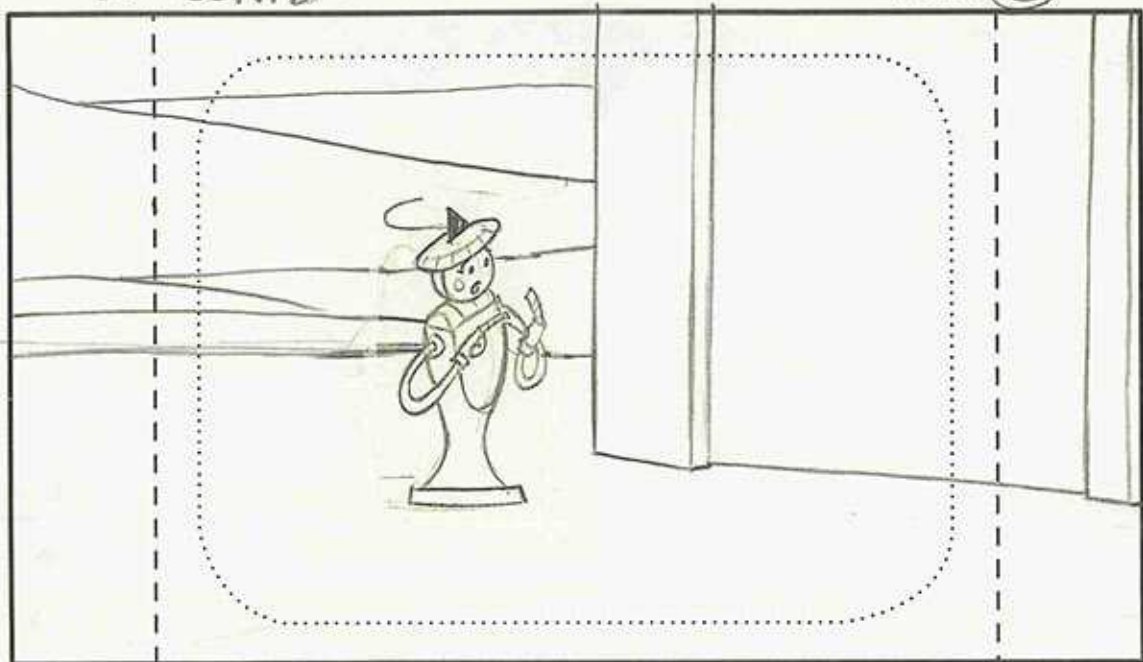

.. THEN RIGHT.

CUT

Dialogue Action

① WISER : (VO) CONTD :

.. THE VERY FIRST PUMP HE VISITS.

Sc. 3

Panel

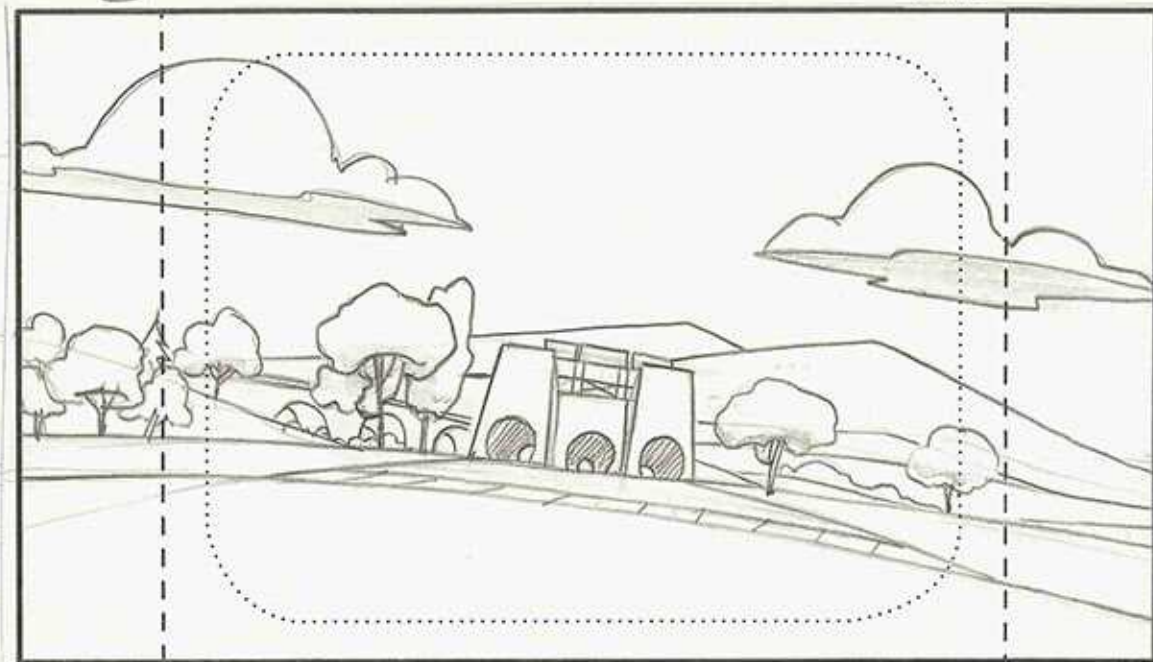

EXT. ROADWAY - DAY.  
PUMPEE'S P.D.V. OF THE EMPTY ROAD.

CUT

Dialogue Action

② WISER ! (VO) CONTD :

BUT THIS MONDAY WAS DIFFERENT.

257-786





# FIREHOUSE TALES

©2005 Warner Bros. This Material is the PROPERTY OF WARNER BROS. TELEVISION ANIMATION. It is unpublished and must not be taken from the studio, duplicated or used in any manner, except for production purposes, and may not be sold or transferred.

Sc. 4

Panel (A)

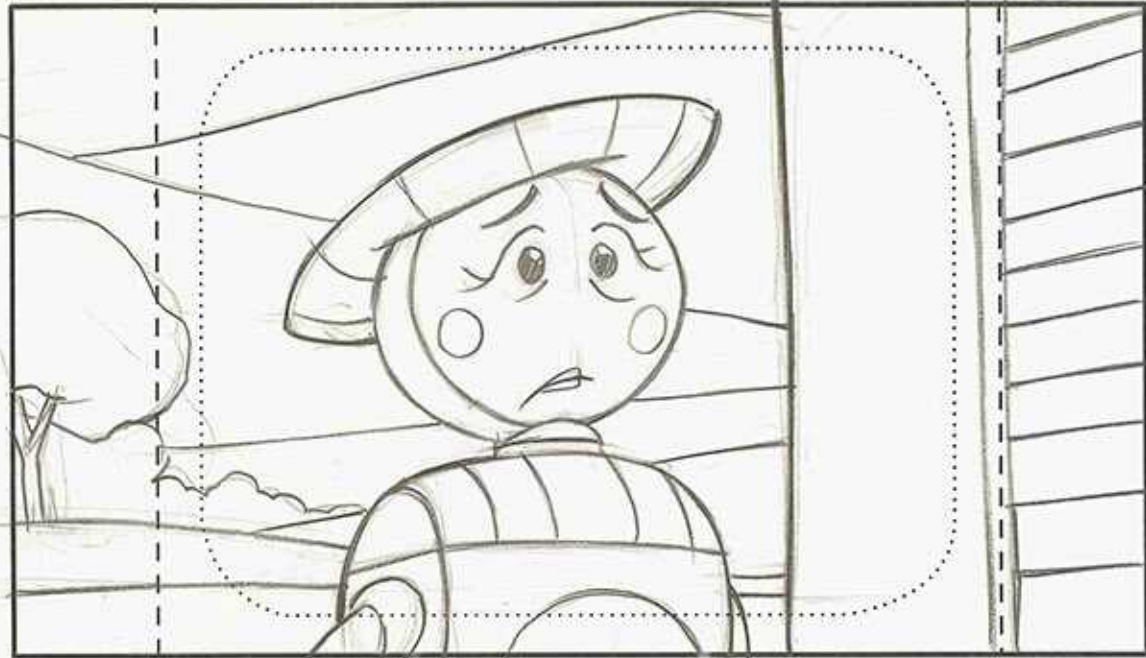

CLOSE ON PUMPEE. LOOKING WORRIED.

Dialogue Action

(2) WISER: (VO) (CONTD)

..TANK DIDN'T ROLL INTO TOWN, AND PUMPEE WAS GETTING WORRIED.

Sc. CONTD

Panel (B)

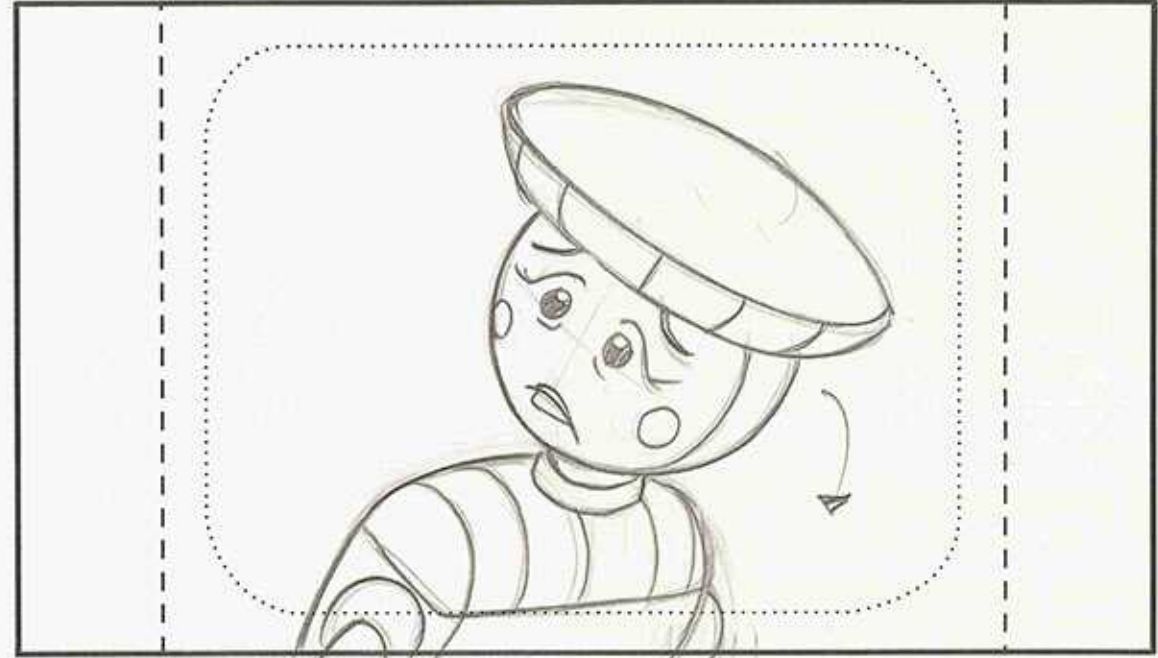

PUMPEE LOOKS DEJECTED!

Dialogue Action



# FIREHOUSE TALES

©2005 Warner Bros. This Material is the PROPERTY OF WARNER BROS. TELEVISION ANIMATION. It is unpublished and must not be taken from the studio, duplicated or used in any manner, except for production purposes, and may not be sold or transferred.

Sc. 4 CONTD.

Panel C

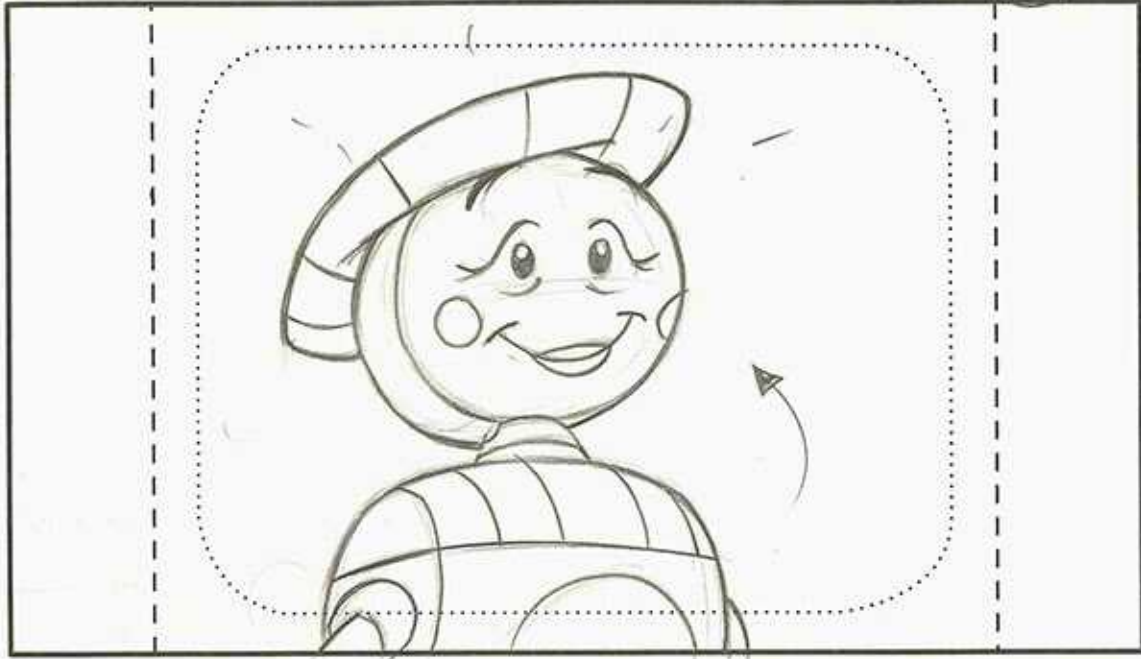

Dialogue Action

PUMPEE PERKS UP, SHE HEARS AN ENGINE IN THE DISTANCE.

CUT

SFX: (ENGINE IN DISTANCE)

Sc. 5

S/A 3 Panel A

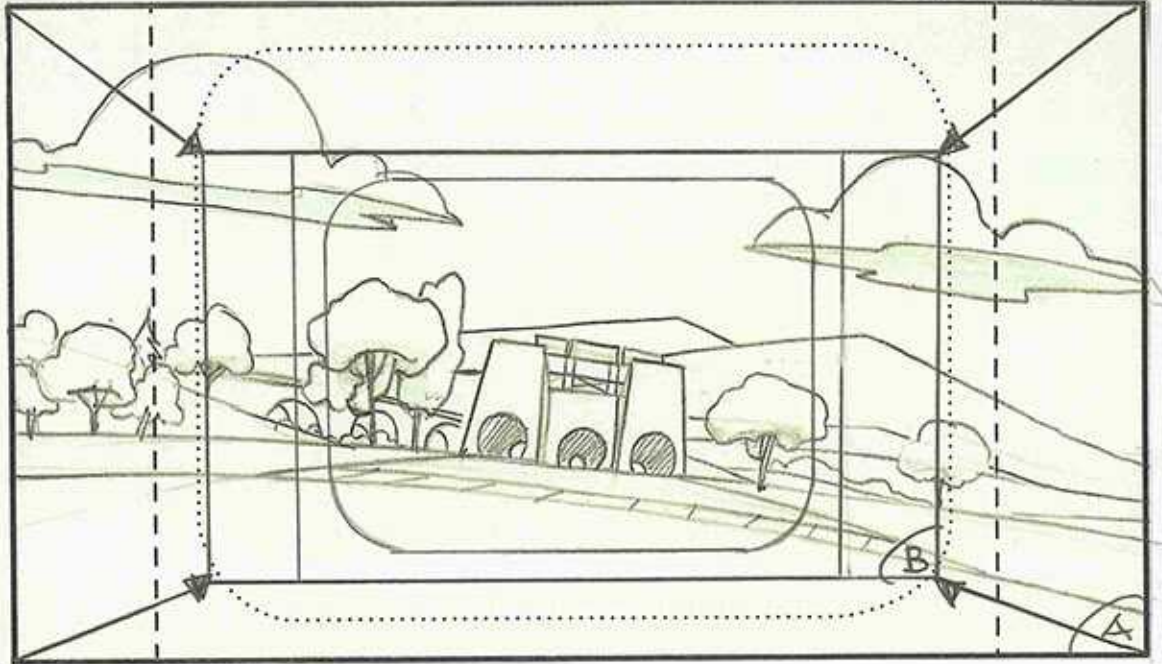

Dialogue Action

PUMPEE'S P.O.V. THE ENGINE NOISES GETS LOUDER. TRUCK IN (A) → (B)

SFX: (ENGINES GETTING CLOSER)





# FIREHOUSE TALES

©2005 Warner Bros. This Material is the PROPERTY OF WARNER BROS. TELEVISION ANIMATION. It is unpublished and must not be taken from the studio, duplicated or used in any manner, except for production purposes, and may not be sold or transferred.

Sc. 5 CONTD.

Panel B

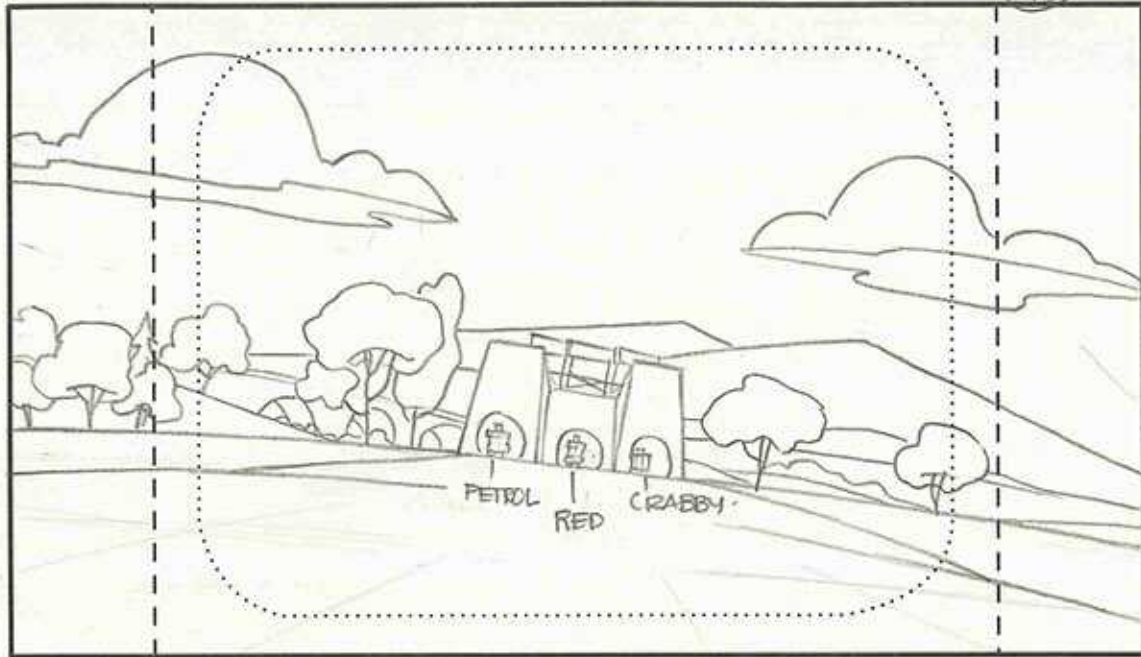

**Dialogue Action** THE SILHOUETTES OF PETROL, RED & CRABBY APPEAR IN THE TUNNEL.

EFX: (SILHOUETTES)

SFX: (ENGINES)

Sc. CONTD.

Panel C

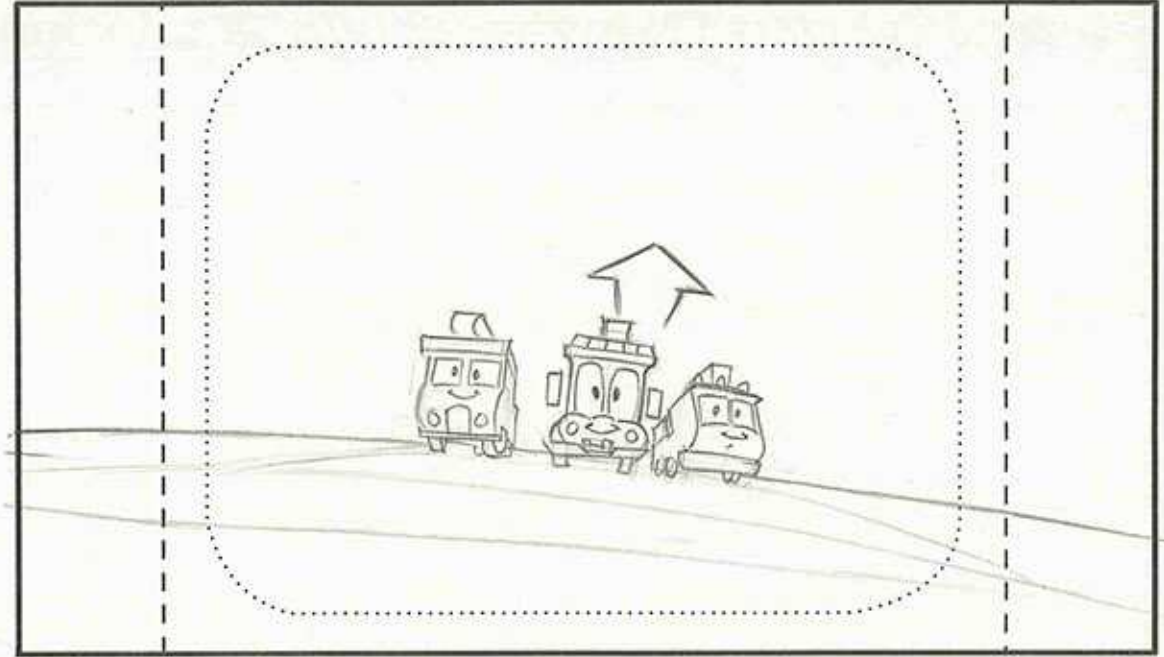

**Dialogue Action** THE TRUCKS DRIVE FORWARD.

CUT



# FIREHOUSE TALES

©2005 Warner Bros. This Material is the PROPERTY OF WARNER BROS. TELEVISION ANIMATION. It is unpublished and must not be taken from the studio, duplicated or used in any manner, except for production purposes, and may not be sold or transferred.

Sc. 6

Panel

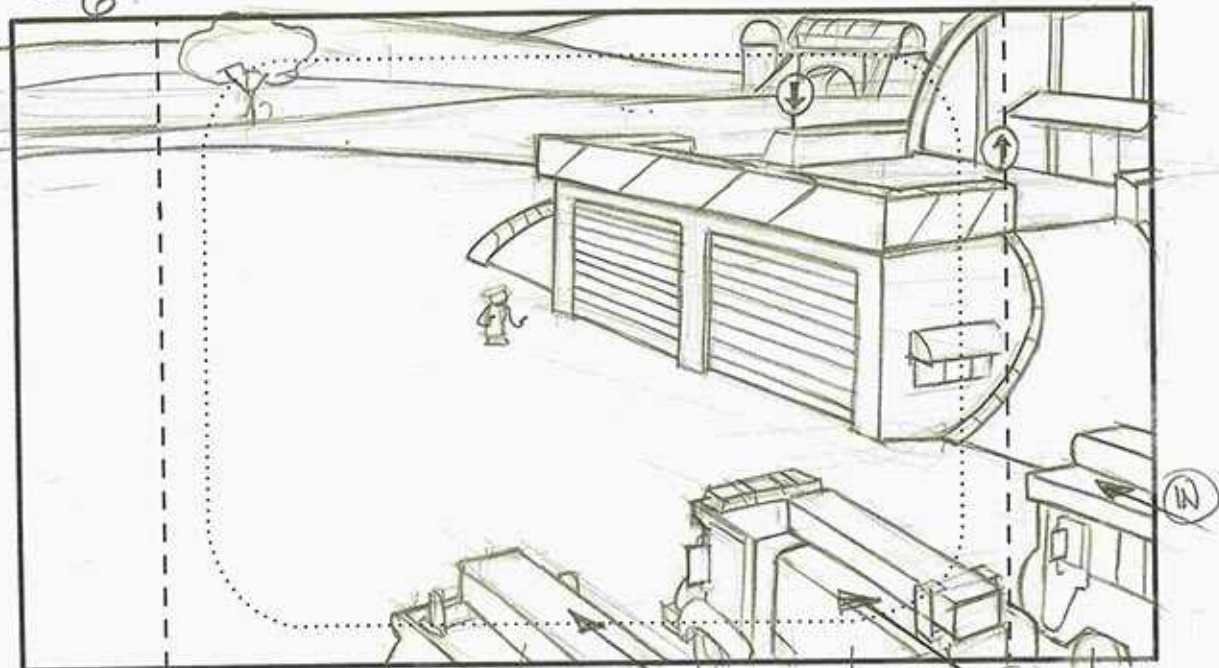

CRABBY (W) RED (W) PETROL (W)

Dialogue Action

(CUT) WIDE ON GARAGE.  
RED, PETROL & CRABBY DRIVE INTO SCENE

SFX: <ENGINES>

Sc. CONTD

Panel (5)

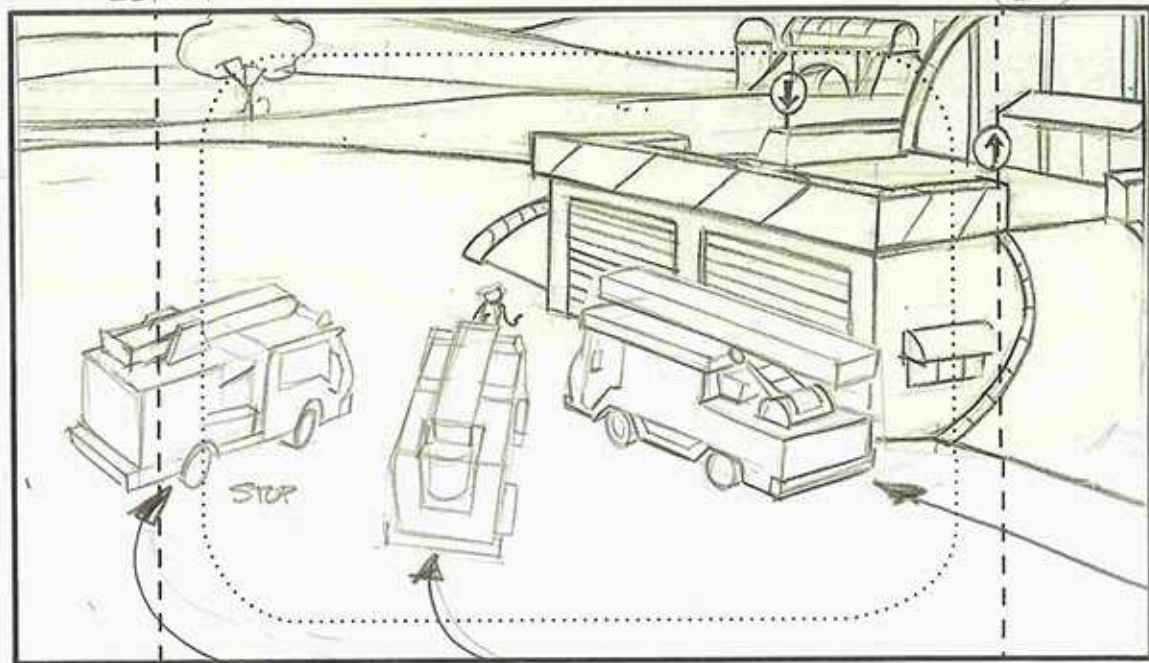

THE GUYS STOP IN FRONT OF PUMPER

Dialogue Action

(HU)  
(CUT)





# FIREHOUSE TALES

©2005 Warner Bros. This Material is the PROPERTY OF WARNER BROS. TELEVISION ANIMATION. It is unpublished and must not be taken from the studio, duplicated or used in any manner, except for production purposes, and may not be sold or transferred.

Sc. 7

S/A A Panel A

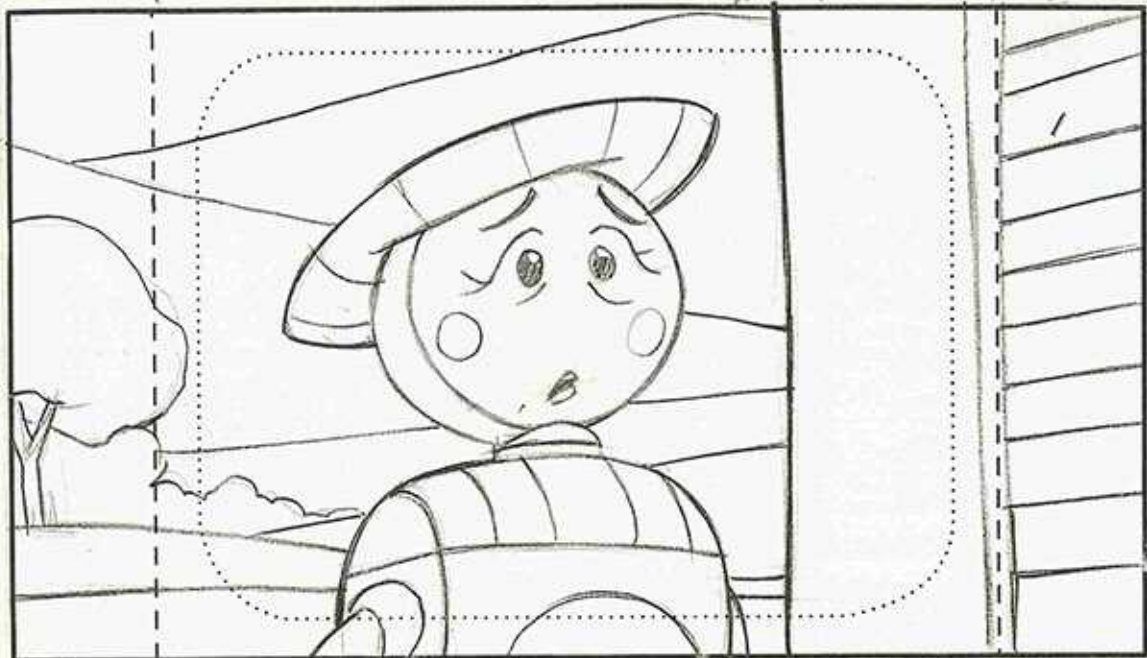

[Hy]  
CUT

Dialogue Action

CLOSE ON PUMPEE

Sc.

CONTD.

Panel B

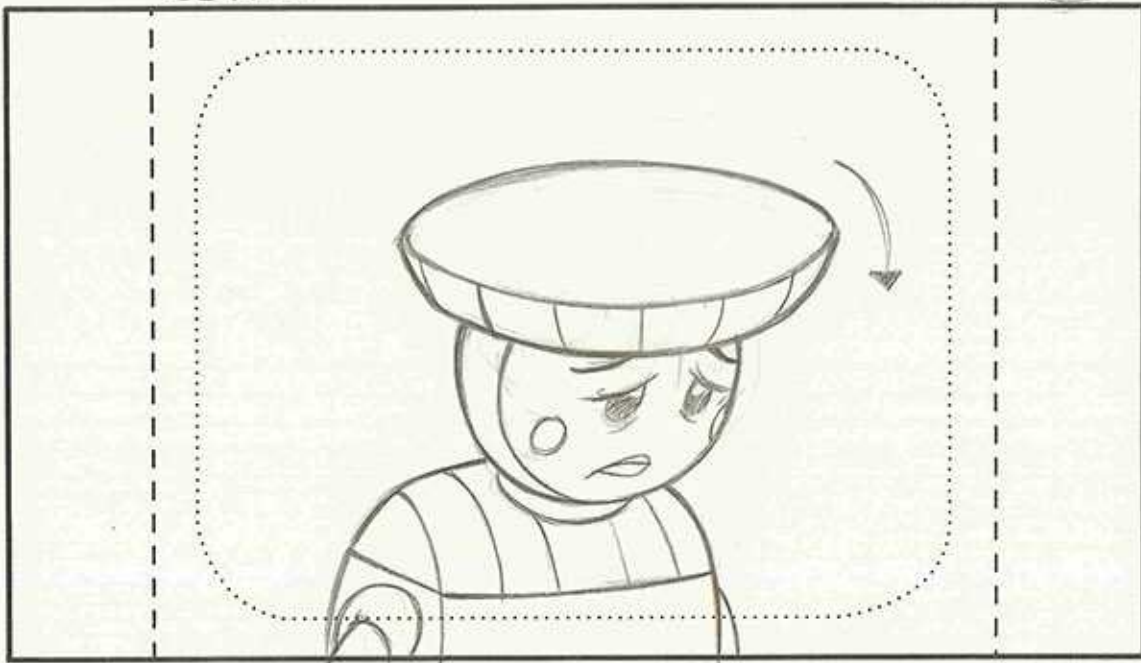

Dialogue Action

SHE SLUMPS FORWARD, DISAPPOINTED

CUT



# FIREHOUSE TALES

©2005 Warner Bros. This Material is the PROPERTY OF WARNER BROS. TELEVISION ANIMATION. It is unpublished and must not be taken from the studio, duplicated or used in any manner, except for production purposes, and may not be sold or transferred.

Sc. 8.

Panel

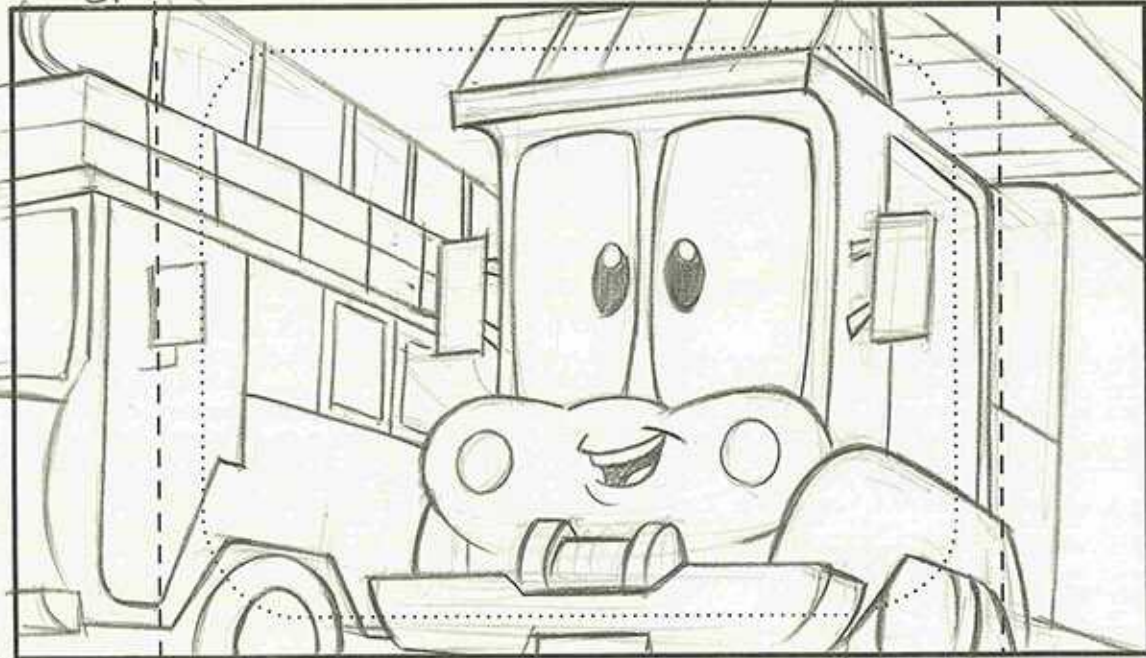

CUT

Dialogue Action

CLOSE ON RED

③ RED:

Hi, PUMPEE! READY TO FILL 'ER UP?

Sc. 9.

Panel

A

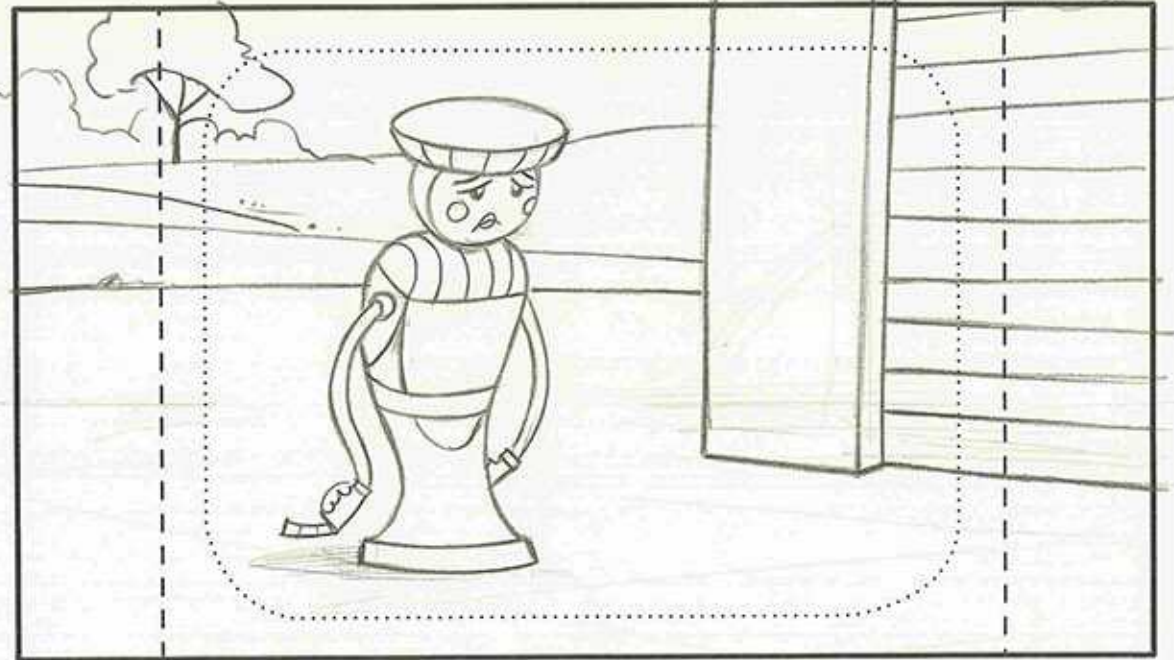

CUT

Dialogue Action

ANGLE ON A SAD PUMPEE





# FIREHOUSE TALES

©2005 Warner Bros. This Material is the PROPERTY OF WARNER BROS. TELEVISION ANIMATION. It is unpublished and must not be taken from the studio, duplicated or used in any manner, except for production purposes, and may not be sold or transferred.

Sc. 9 CONTD

Panel B

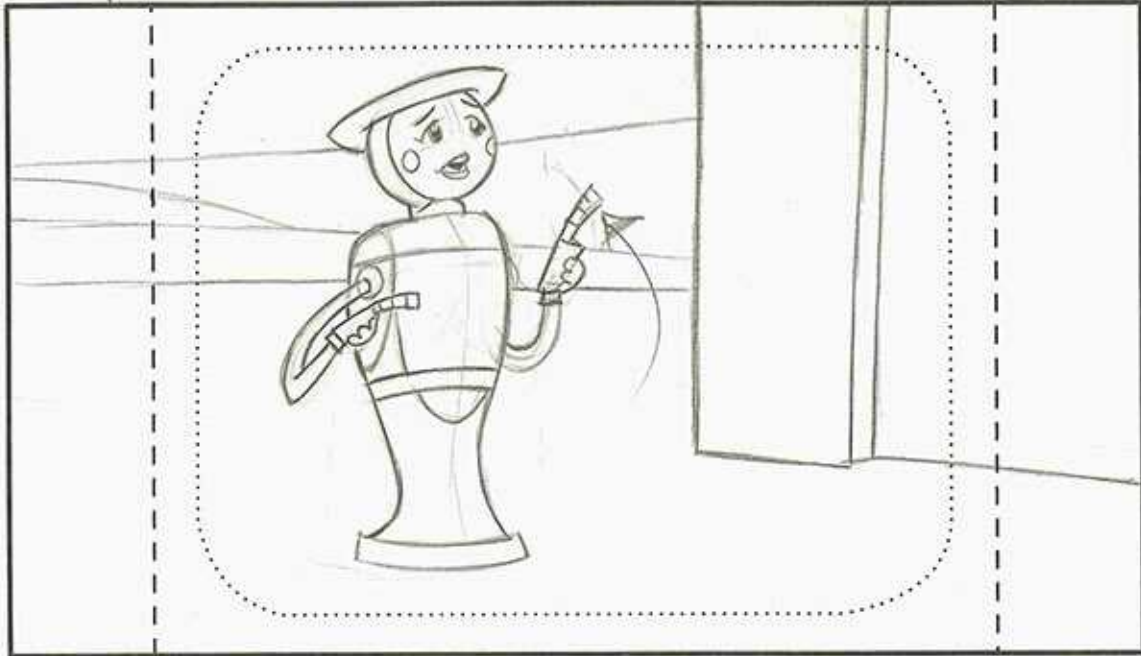

Dialogue Action

PUMPEE LOCKS UP

CUT

④ PUMPEE: (WORRIED)

Hi, BOYS, HAVE YOU SEEN TANK THIS MORNING?

Sc. 10

Panel

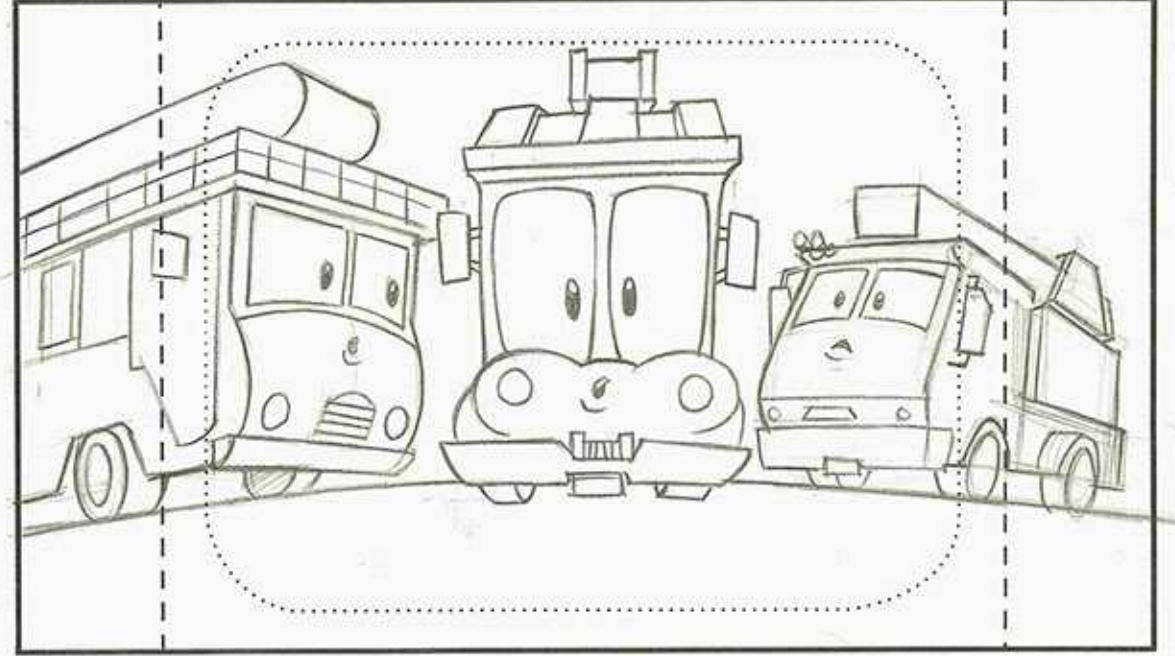

Dialogue Action

ANGLE ON THE THREE TRUCKS

CUT

⑤ RED/PETROL/CRABBY:

UH UH, NOPE, HAVENT SEEN HIM.



# FIREHOUSE TALES

©2005 Warner Bros. This Material is the PROPERTY OF WARNER BROS. TELEVISION ANIMATION. It is unpublished and must not be taken from the studio, duplicated or used in any manner, except for production purposes, and may not be sold or transferred.

Sc. 11

Panel

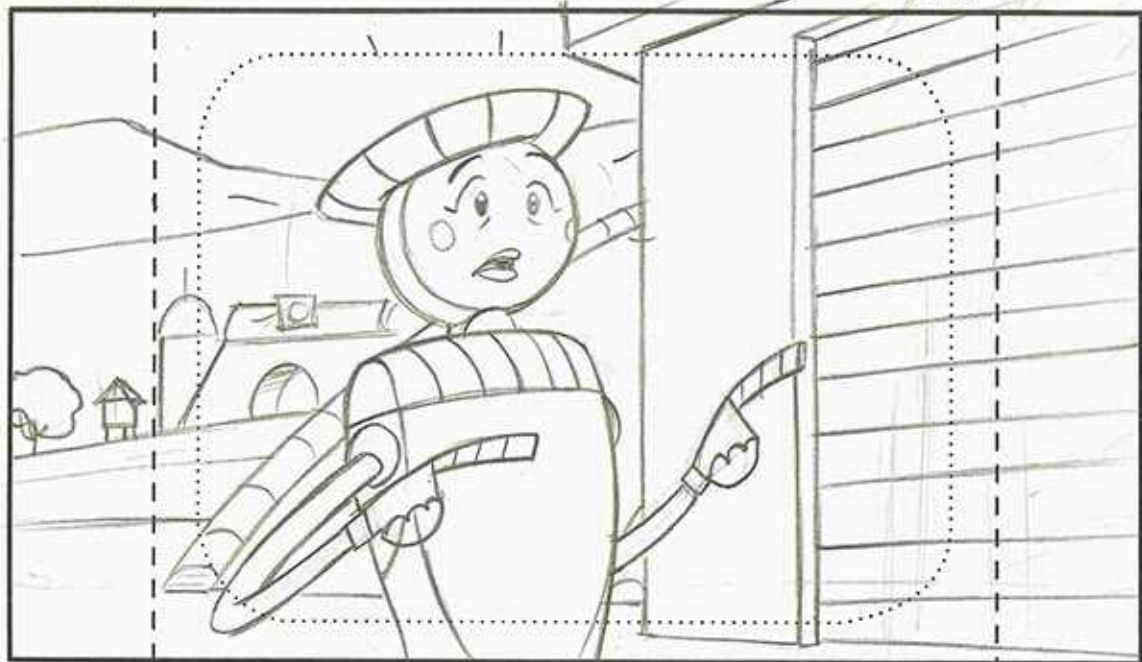

CUT

Action

CLOSE ON PUMPEE REACTING

CUT

5A PUMPEE:

<REACT>

Sc. 12

5A9

Panel

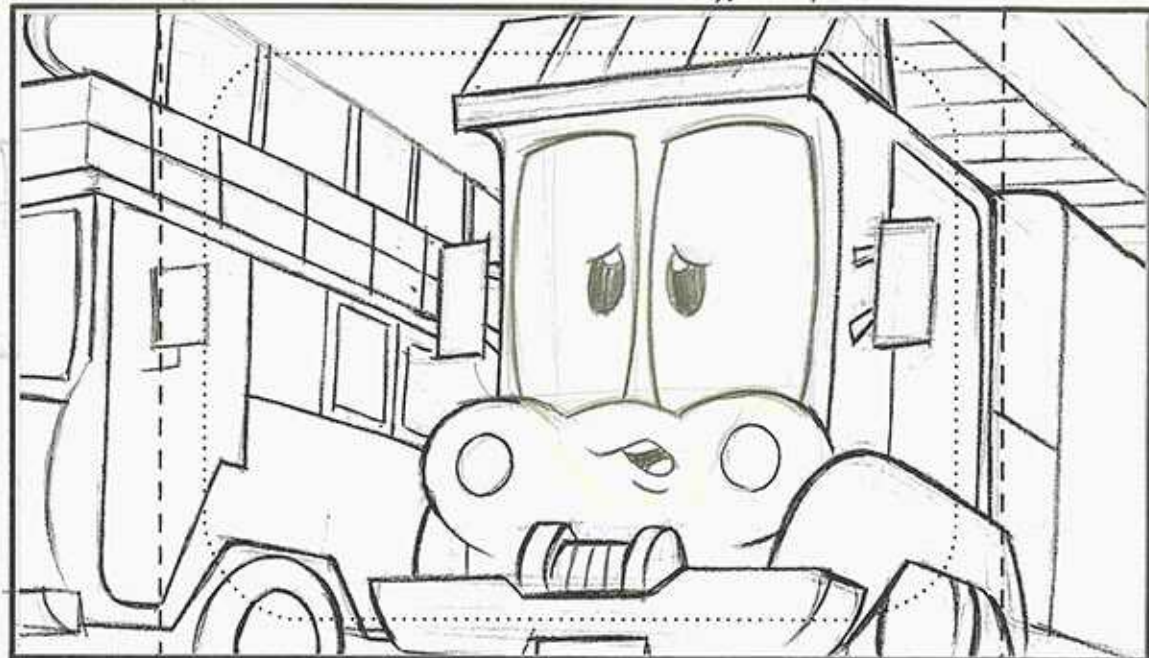

Action

CLOSE ON A CONCERNED RED

CUT

6 RED: (CONCERNED)

WHAT'S WRONG PUMPEE?





# FIREHOUSE TALES

©2005 Warner Bros. This Material is the PROPERTY OF WARNER BROS. TELEVISION ANIMATION. It is unpublished and must not be taken from the studio, duplicated or used in any manner, except for production purposes, and may not be sold or transferred.

Sc. 13

Panel A

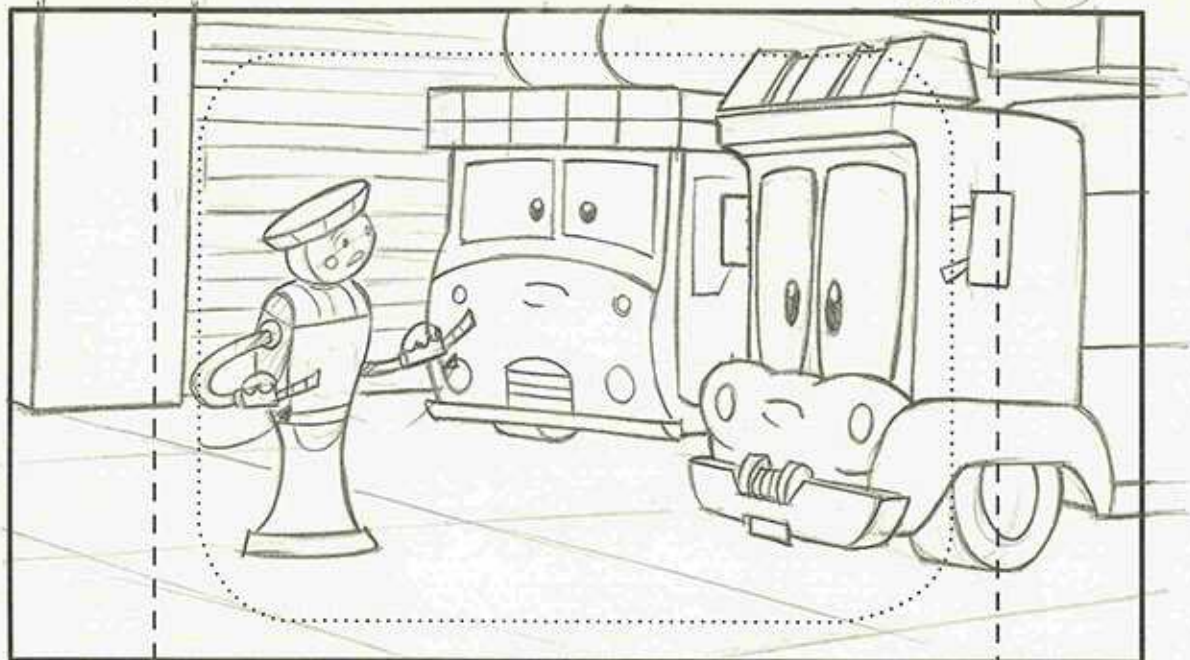

CUT

Dialogue Action

WIDE ON PUMPEE, RED & PETROL.

⑦ PUMPEE:

TANK HASN'T COME TO REFILL THE FIREHOUSE GAS TANKS..

Sc. CONTD

Panel B

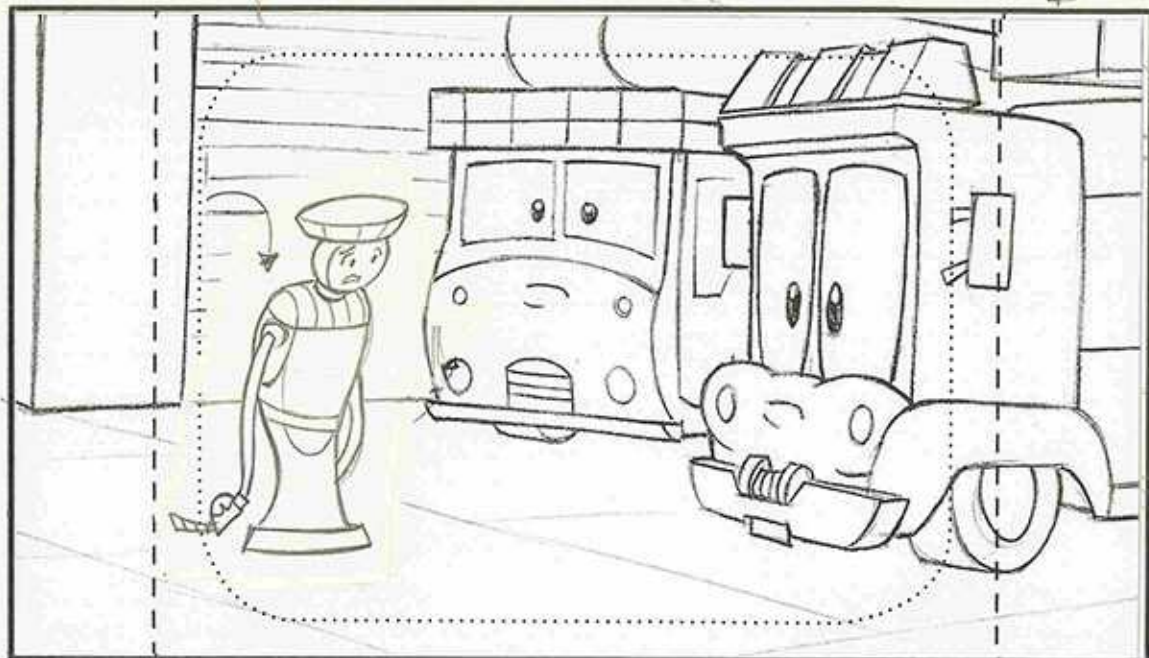

Dialogue Action

PUMPEE IS DEJECTED.

Hel

CUT

⑦ PUMPEE: (CONTD)

..YET AND ... AND ..

257-786



# FIREHOUSE TALES

©2005 Warner Bros. This Material is the PROPERTY OF WARNER BROS. TELEVISION ANIMATION. It is unpublished and must not be taken from the studio, duplicated or used in any manner, except for production purposes, and may not be sold or transferred.

Page 13

Sc. A

SA 4 Panel A

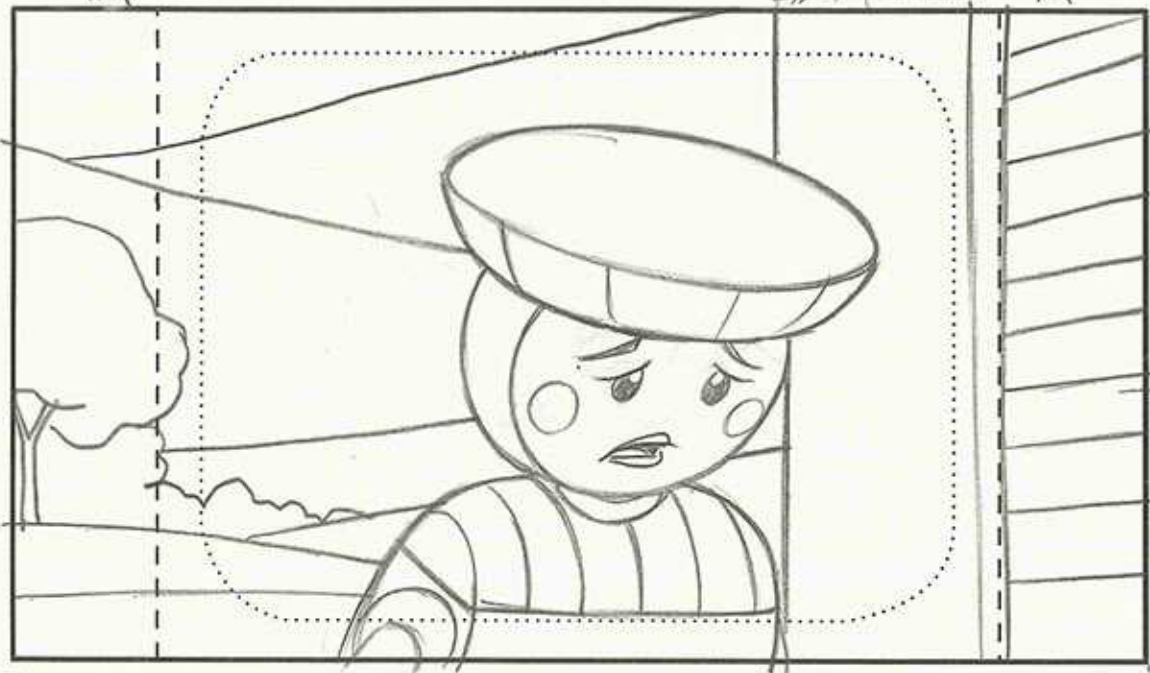

HU

CUT

Dialogue Action

CLOSE ON PUMPEE.

⑦ PUMPEE : (CONTD)

.. AND ..

Sc. CONTD

Panel B

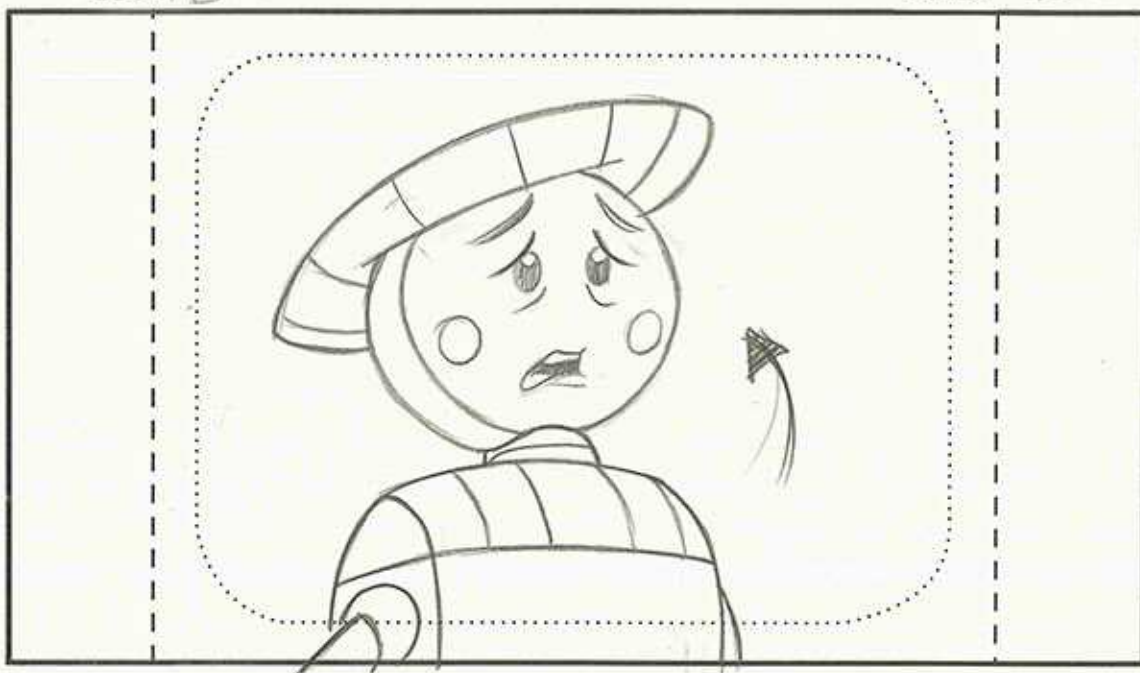

Dialogue Action

PUMPEE LOOKS UP

CUT

⑦ PUMPEE : (CONTD)

.. I'M EMPTY!

257-786





# FIREHOUSE TALES

©2005 Warner Bros. This Material is the PROPERTY OF WARNER BROS. TELEVISION ANIMATION. It is unpublished and must not be taken from the studio, duplicated or used in any manner, except for production purposes, and may not be sold or transferred.

Sc. 15

SA 11 Panel

(A)

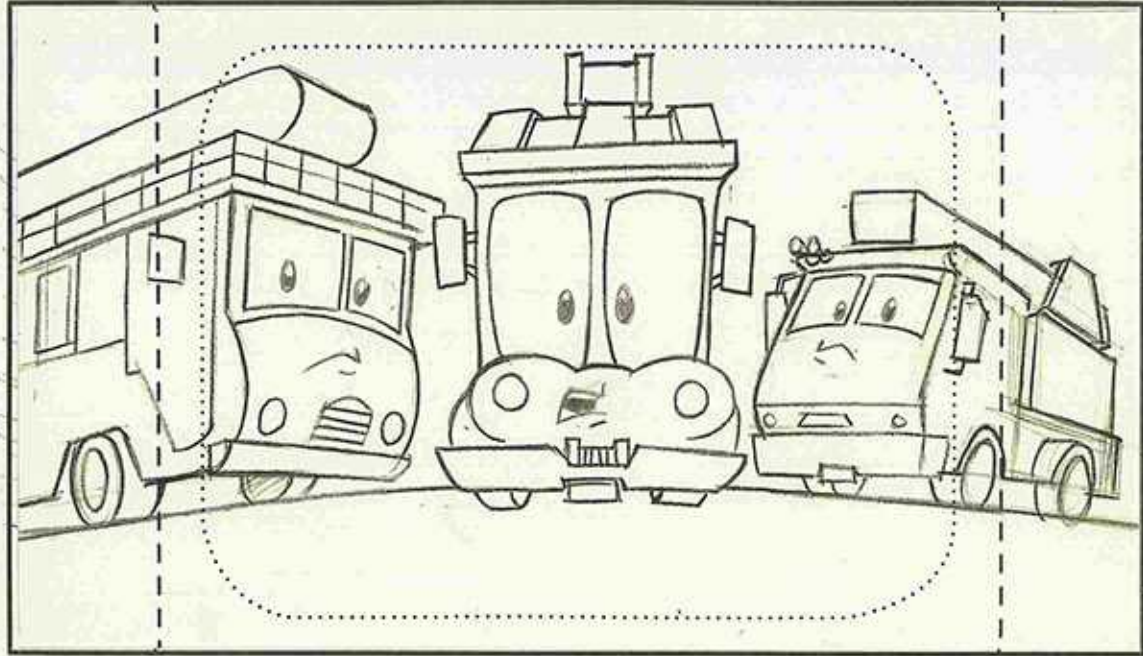

CUT

Dialogue Action

WIDE ON THE TRUCKS REACTING

9 RED:

OH NO... AND I'M ALMOST EMPTY!

Sc. CONTD

Panel

(B)

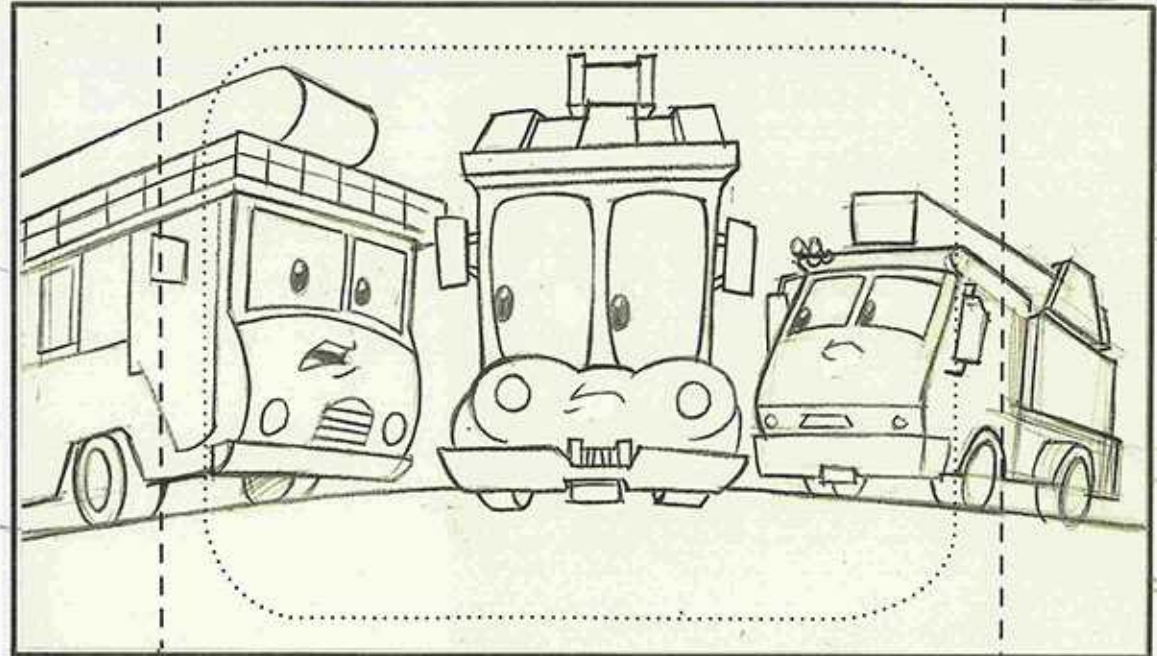

CUT

Dialogue Action

10 PETROL:

BUST ME BLINKERS, ME TOO!





# FIREHOUSE TALES

©2005 Warner Bros. This Material is the PROPERTY OF WARNER BROS. TELEVISION ANIMATION. It is unpublished and must not be taken from the studio, duplicated or used in any manner, except for production purposes, and may not be sold or transferred.

Sc. 16

Panel

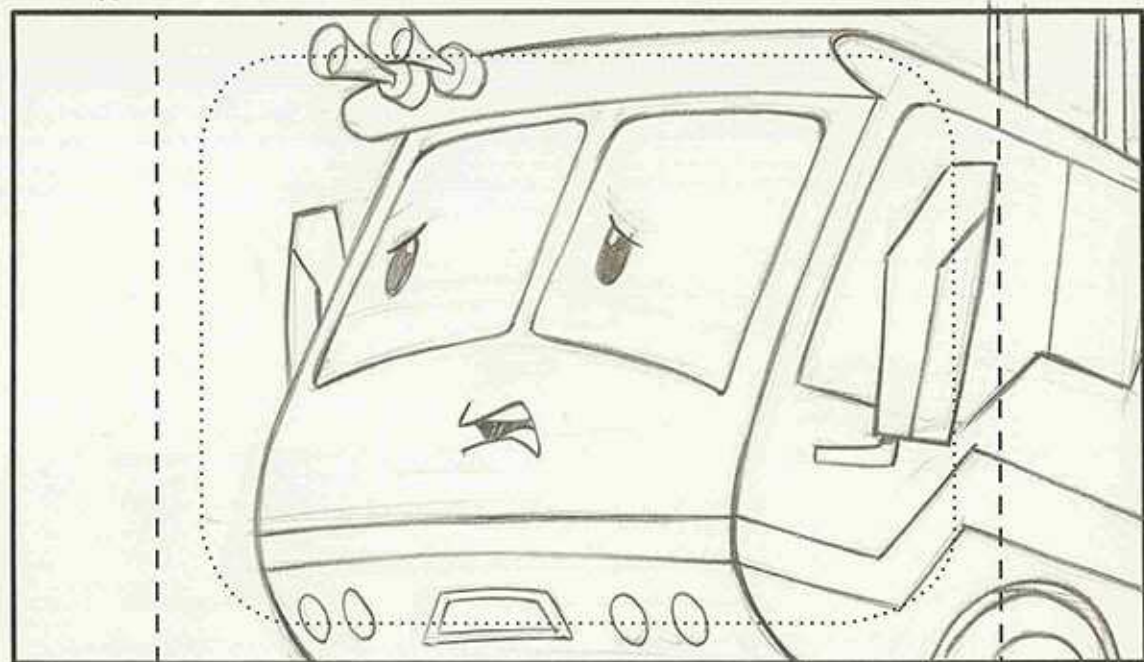

CLOSE ON CRABBY.

Dialogue Action

⑪ CRABBY:

I DROVE HERE ON FUMES!

CUT

Sc. 17

SA.14 Panel

(A)

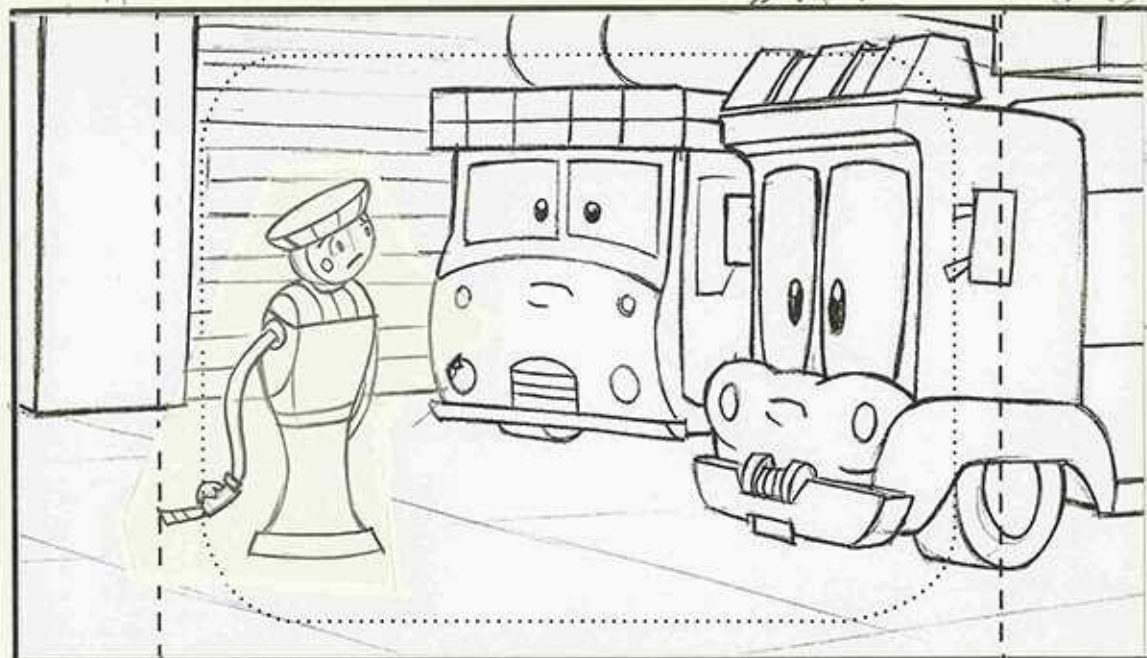

WIDER ON PUMPEE, PETROL & RED.

Dialogue Action

⑫ RED:

I'M SORRY PUMPEE, BUT IT LOOKS LIKE WE'RE GOING TO HAVE TO GO TO ANOTHER GAS PUMP TODAY.





# FIREHOUSE TALES

©2005 Warner Bros. This Material is the PROPERTY OF WARNER BROS. TELEVISION ANIMATION. It is unpublished and must not be taken from the studio, duplicated or used in any manner, except for production purposes, and may not be sold or transferred.

Sc. 17 CONTD

Panel B

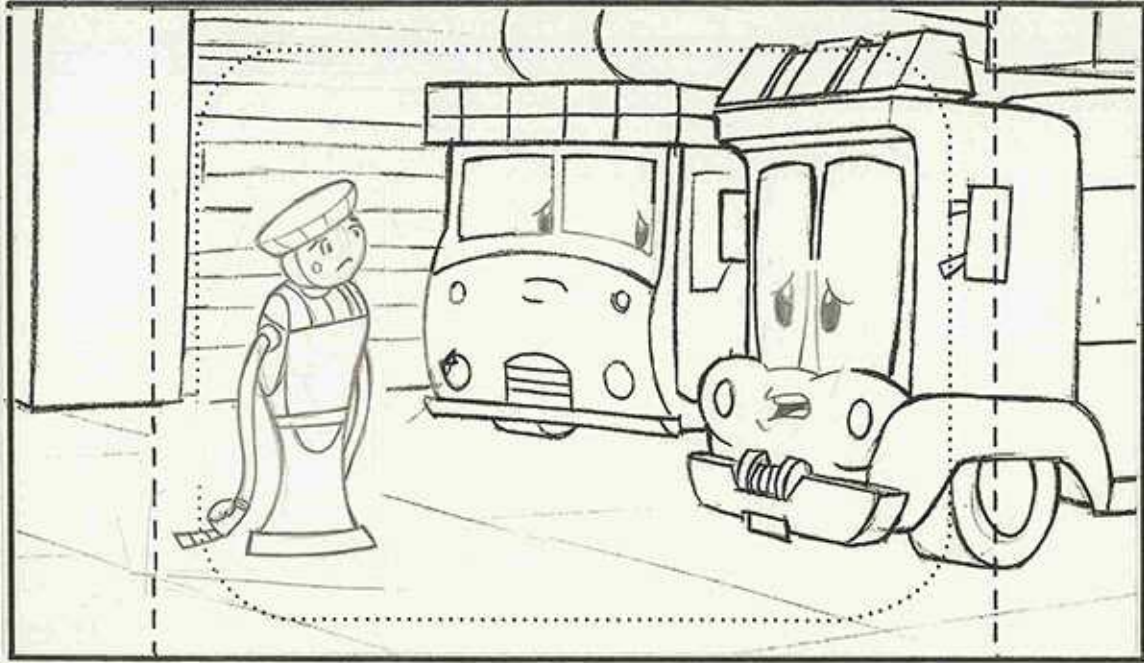

Dialogue Action

CUT

⑫ RED: (CONTD)

WE NEED GAS!

Sc. 18

S/A 4 Panel A

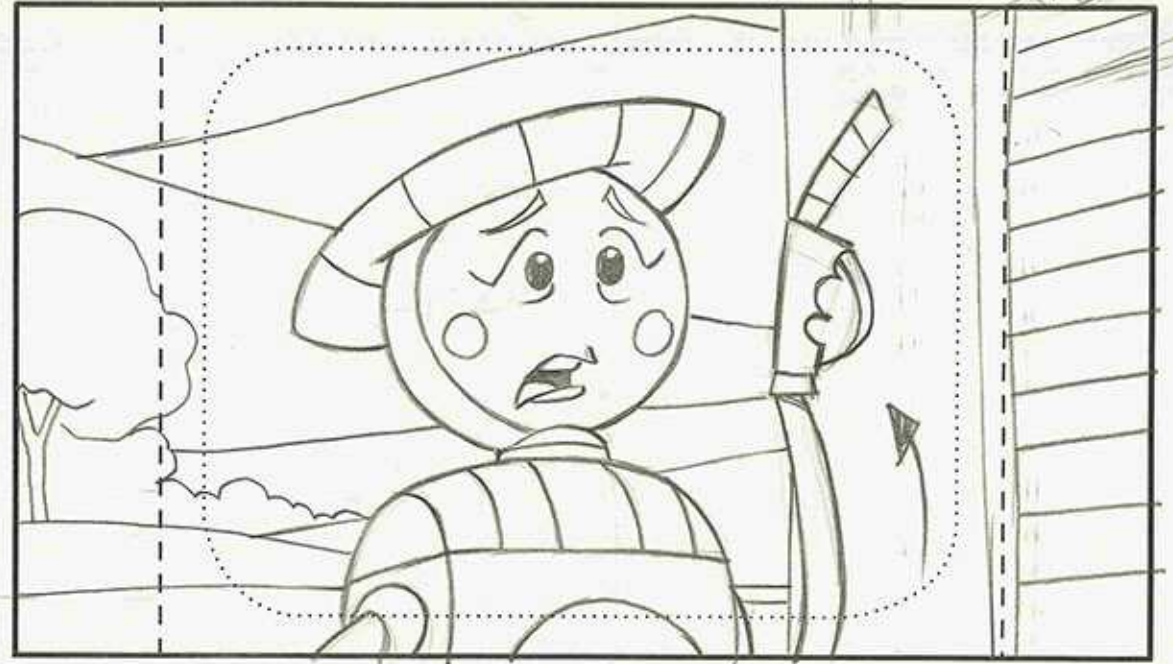

Dialogue Action

CUT

CLOSE ON PUMPEE

⑬ PUMPEE:

BUT TANK ALWAYS COMES TO MY PUMP FIRST...

257-786



# FIREHOUSE TALES

©2005 Warner Bros. This Material is the PROPERTY OF WARNER BROS. TELEVISION ANIMATION. It is unpublished and must not be taken from the studio, duplicated or used in any manner, except for production purposes, and may not be sold or transferred.

Sc. 18 CONTD

Panel (B)

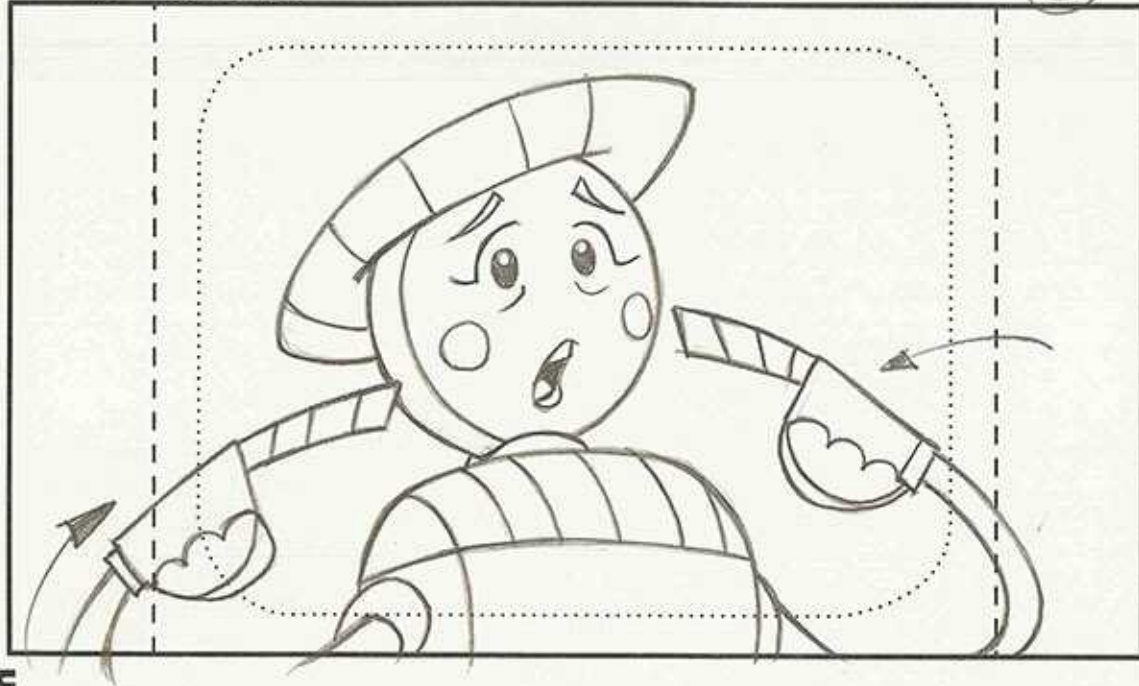

Dialogue Action

(13) PUMPEE: (CONTD)

.. WHICH MEANS I'M NOT THE ONLY EMPTY TANK IN GREEN MEADOWS.

Sc.

Panel

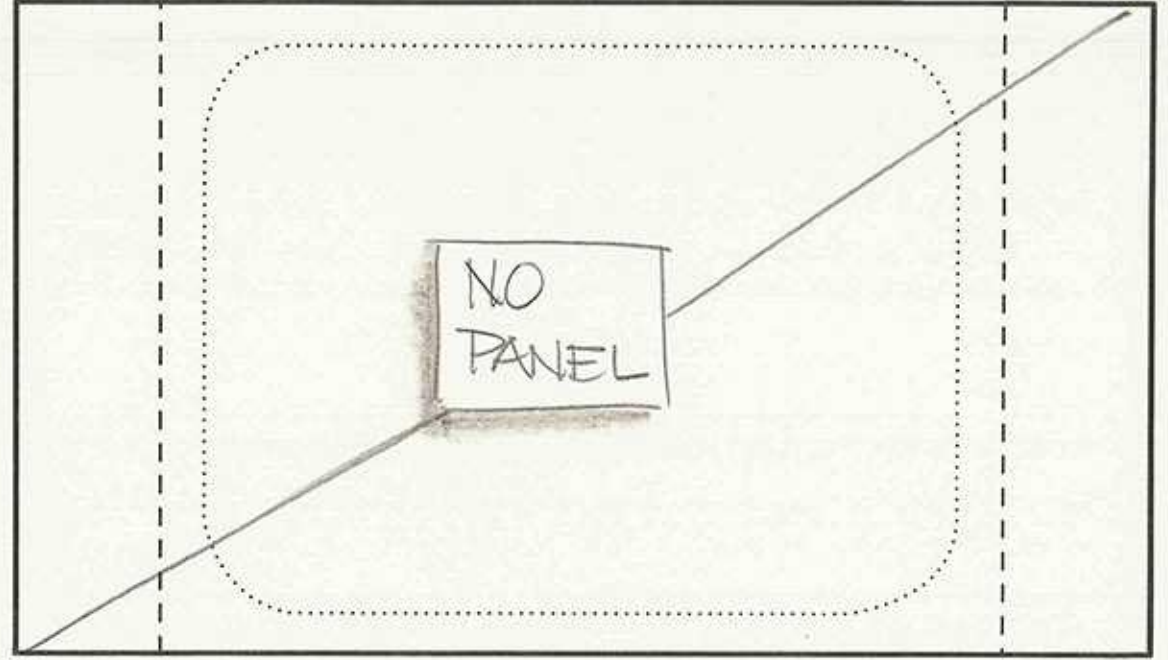

Dialogue Action





# FIREHOUSE TALES

©2005 Warner Bros. This Material is the PROPERTY OF WARNER BROS. TELEVISION ANIMATION. It is unpublished and must not be taken from the studio, duplicated or used in any manner, except for production purposes, and may not be sold or transferred.

Sc. 19

Panel

CARS

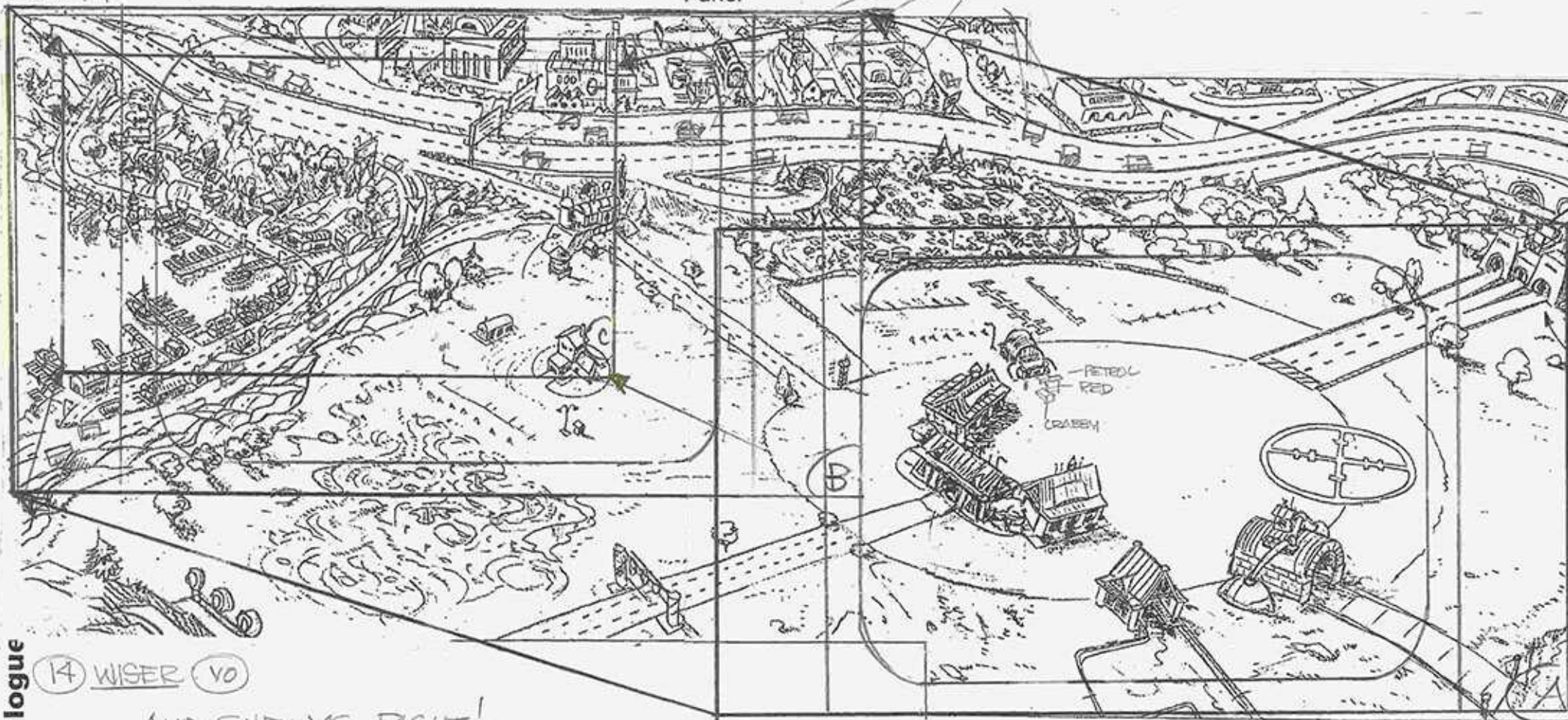

EXT. D.N.SHOT  
FIREHOUSE -DAY  
DA PAN (A) ->(B)  
NO HOLD  
CONTINUE PAN  
& TRK IN (B) ->(C)  
CARS ALONG THE  
ROADS SLOW TO A  
STOP.



Dialogue

(14) WISER (VO)

AND SHE WAS RIGHT!

257-786





# FIREHOUSE TALES

©2005 Warner Bros. This Material is the PROPERTY OF WARNER BROS. TELEVISION ANIMATION. It is unpublished and must not be taken from the studio, duplicated or used in any manner, except for production purposes, and may not be sold or transferred.

Page 18.

Sc. 20

Panel

EXT. STREET #1 - (DAY)

D.I.A PAN (A) → (B)

PAN ALONG ROAD. CARS ARE STOPPED

X-DISS FROM:



Action  
Dialogue

(15) WISER: (VO)

THE WHOLE CITY WAS RUNNING OUT OF GAS.

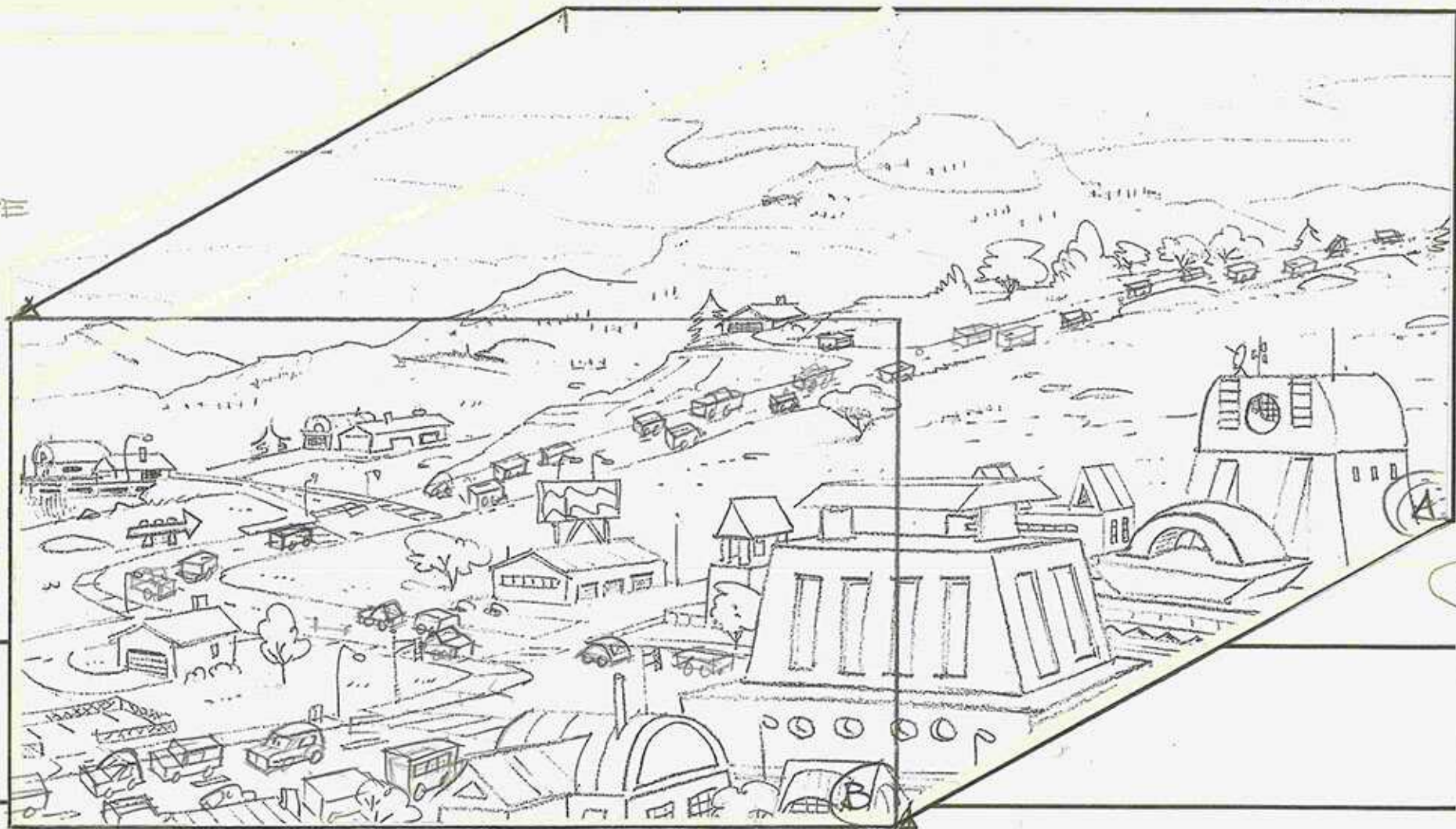

cut

257-786





# FIREHOUSE TALES

©2005 Warner Bros. This Material is the PROPERTY OF WARNER BROS. TELEVISION ANIMATION. It is unpublished and must not be taken from the studio, duplicated or used in any manner, except for production purposes, and may not be sold or transferred.

Sc. 21 CONT'D

Panel (C)

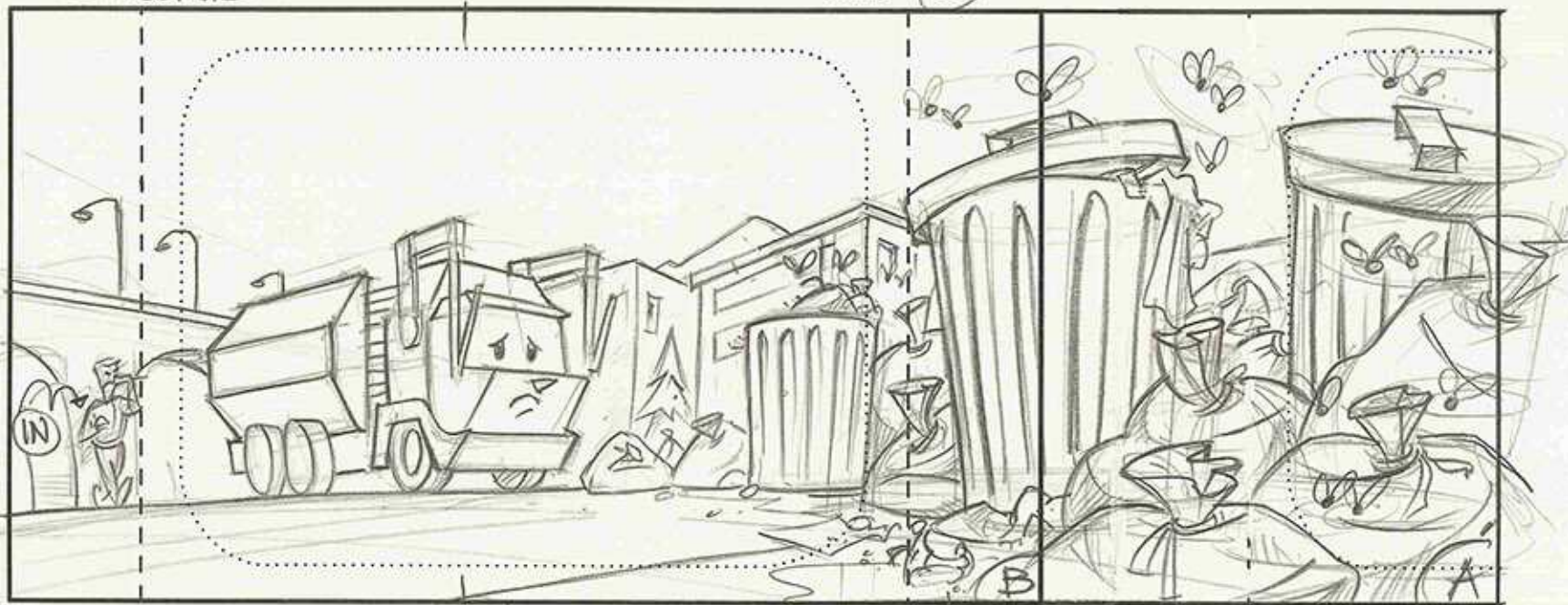

**Dialogue Action**  
EXT CITY STREET - STOP ANGLE ON SMELLY GARBAGE  
PAN (A) → (B) STINKY IS OUT OF GAS AND DOESN'T  
LOOK PLEASED

**Dialogue Action**

CUT

257-786





# FIREHOUSE TALES

©2005 Warner Bros. This Material is the PROPERTY OF WARNER BROS. TELEVISION ANIMATION. It is unpublished and must not be taken from the studio, duplicated or used in any manner, except for production purposes, and may not be sold or transferred.

Sc. 22

Panel

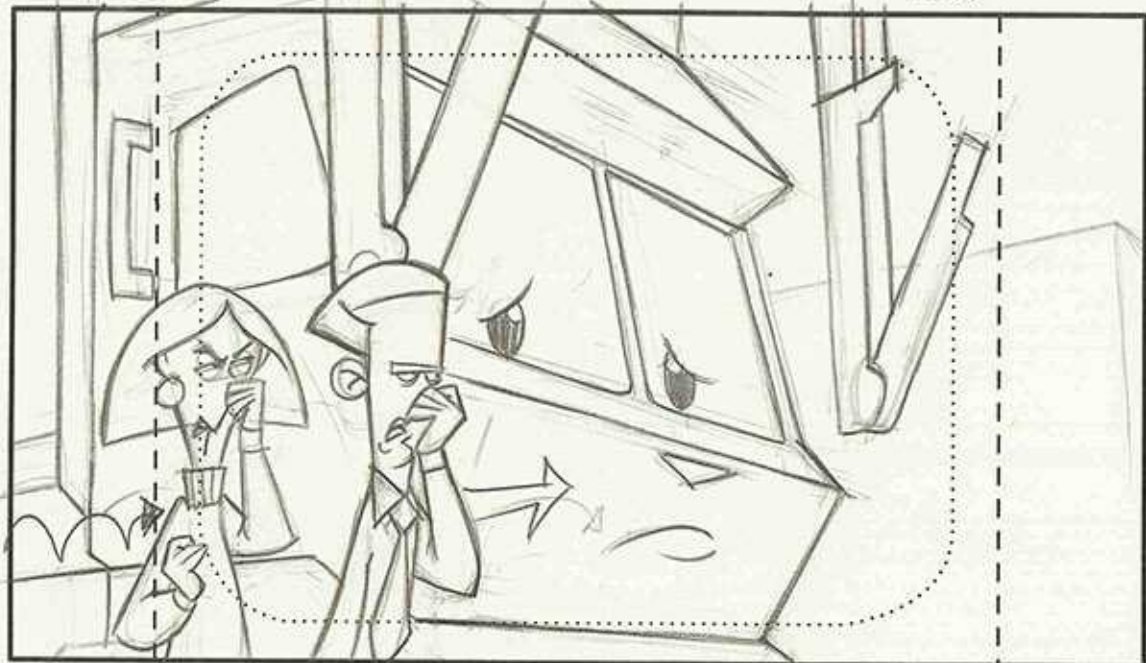

#14

ADULT #15

CLOSE ON STINKY. A COUPLE WALK BY HOLDING THEIR NOSES.

CUT  
Dialogue Action

15A PEOPLE:

< REACT >

Sc.

Panel

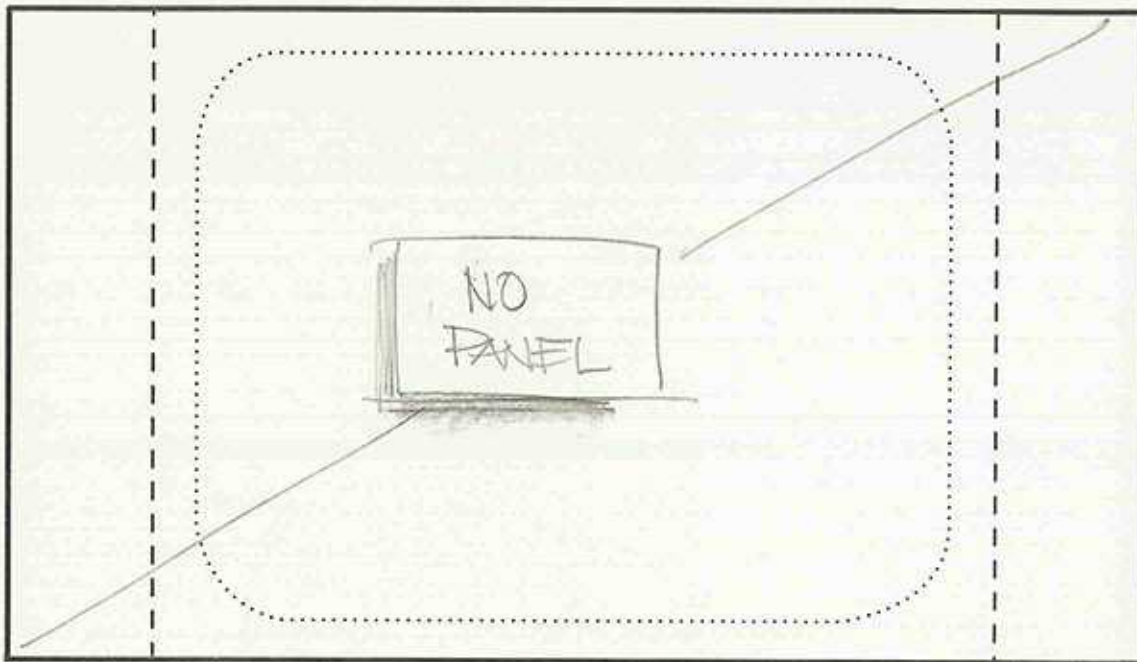

Dialogue Action





# FIREHOUSE TALES

©2005 Warner Bros. This Material is the PROPERTY OF WARNER BROS. TELEVISION ANIMATION. It is unpublished and must not be taken from the studio, duplicated or used in any manner, except for production purposes, and may not be sold or transferred.

Sc. 23

Panel

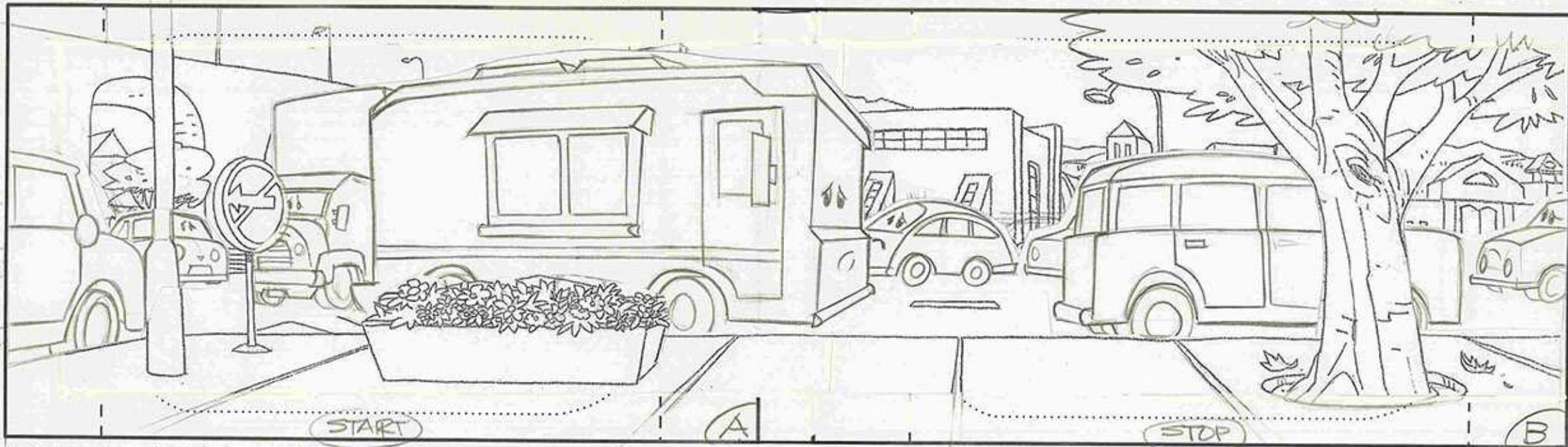

**CUT** EXT ANGLE ON ANOTHER CITY STREET - DAY.  
 PAN (A) → (B) PAN ALONG A LINE OF OUT OF GAS CARS.

**Dialogue Action**

(16) WISER : (VO)

IT WAS CREATING TERRIBLE TROUBLE.

**Dialogue Action**

**CUT**

257-786





# FIREHOUSE TALES

©2005 Warner Bros. This Material is the PROPERTY OF WARNER BROS. TELEVISION ANIMATION. It is unpublished and must not be taken from the studio, duplicated or used in any manner, except for production purposes, and may not be sold or transferred.

Sc. 24

Panel (A)

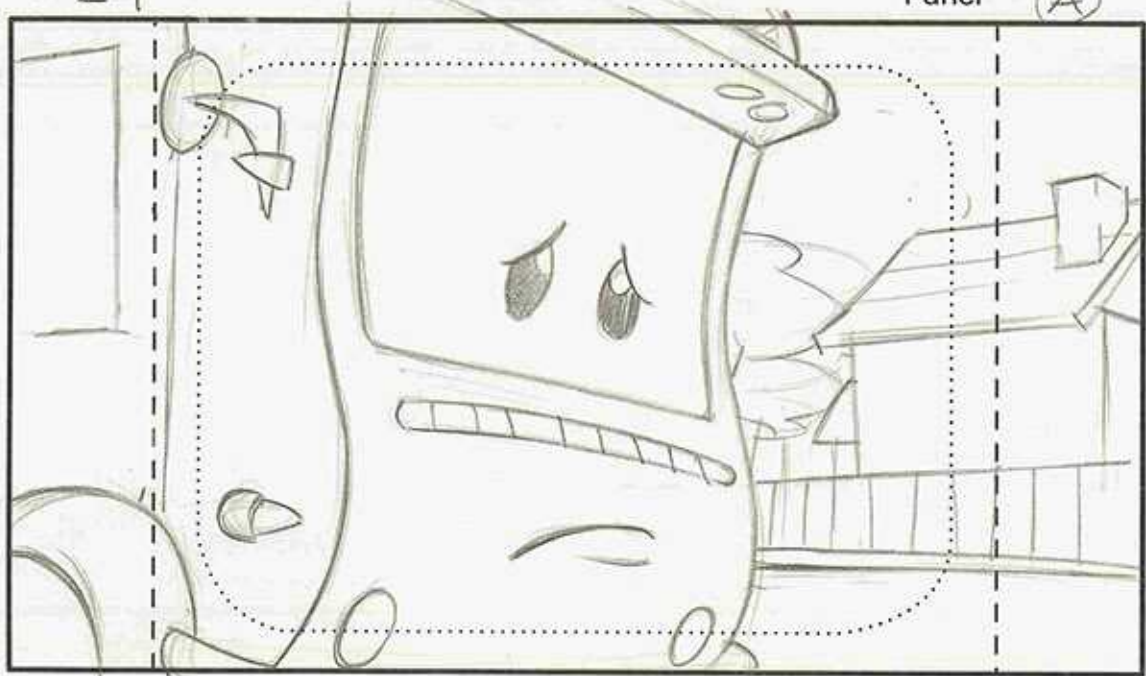

CUT

Dialogue Action

EXT. SUBURBAN STREET - (DAY)  
ANGLE ON A FORLORN MILKIE

Sc. CONTD.

Panel (B)

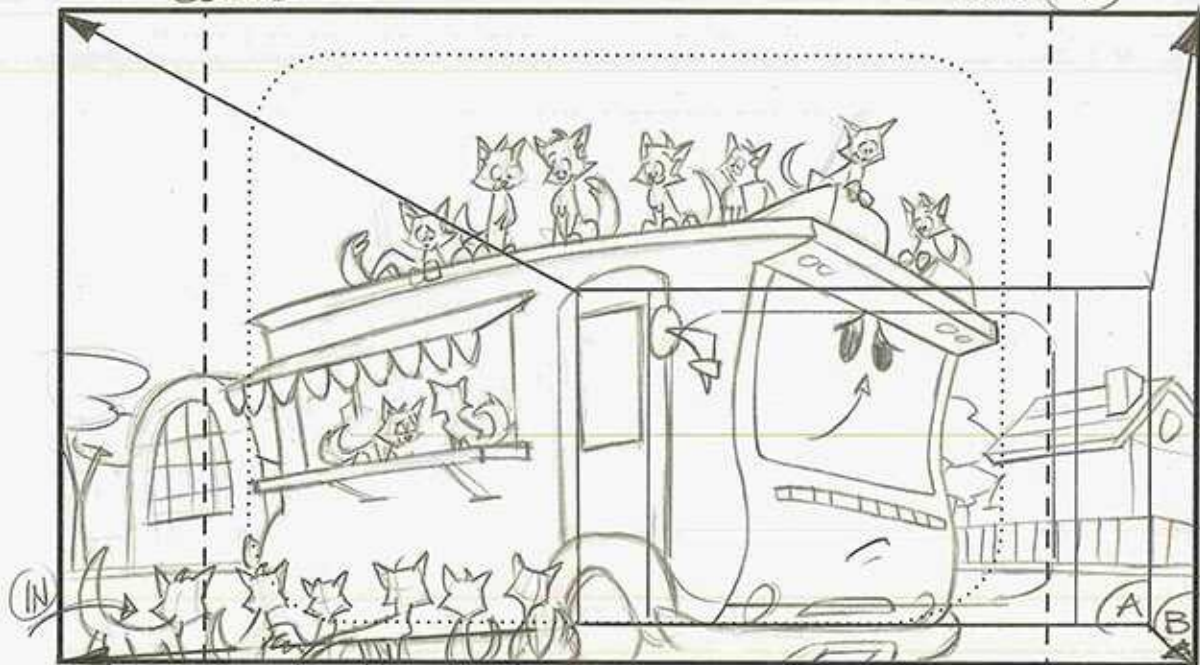

Dialogue Action

TRUCK OUT (A) → (B). MILKIE IS COVERED IN CATS.  
MORE RUN IN

CUT

(17) WISER: (VO)

THE ONLY ONES WHO WERE HAPPY WERE  
THE CATS NEAR MILKIE.





# FIREHOUSE TALES

©2005 Warner Bros. This Material is the PROPERTY OF WARNER BROS. TELEVISION ANIMATION. It is unpublished and must not be taken from the studio, duplicated or used in any manner, except for production purposes, and may not be sold or transferred.

Sc. 25

Panel

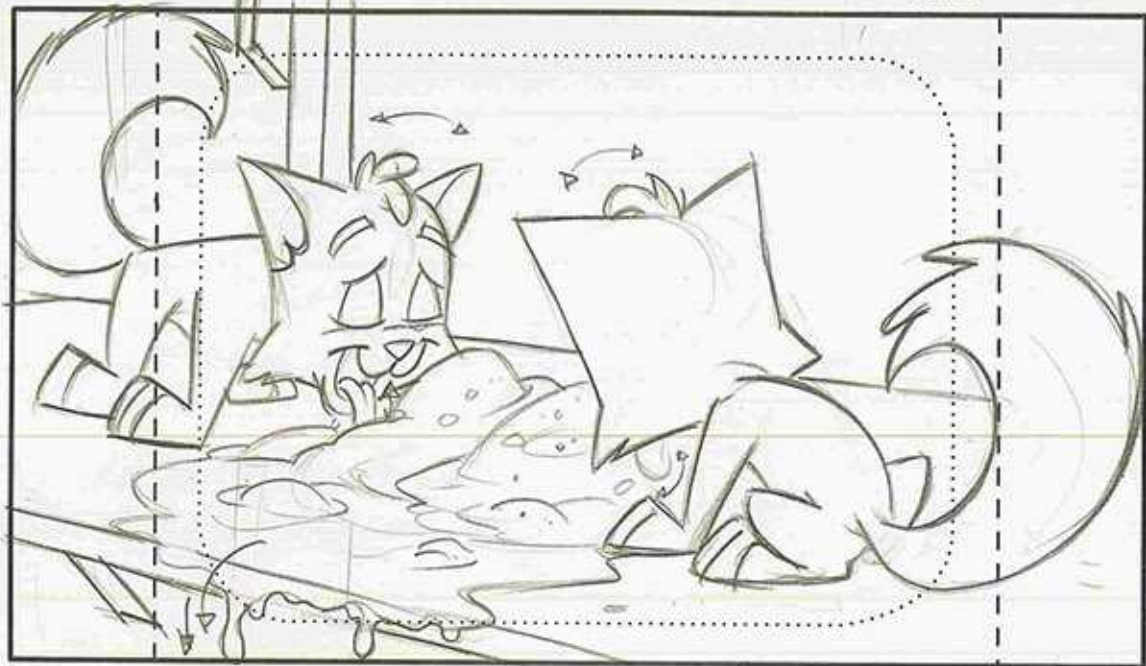

**CUT**  
**Action** CLOSE ON OPEN SERVING WINDOW - (MILK) MELTED ICE CREAM PUDDLES ON THE COUNTER. CATS LICK UP THE TASTY TREAT

**EFX:** < SFT DRIP >

**(18) WISER:**

SOMEONE HAD TO DRINK ALL THAT MELTED ICE CREAM.

**CUT**

Sc. 26

Panel

(A)

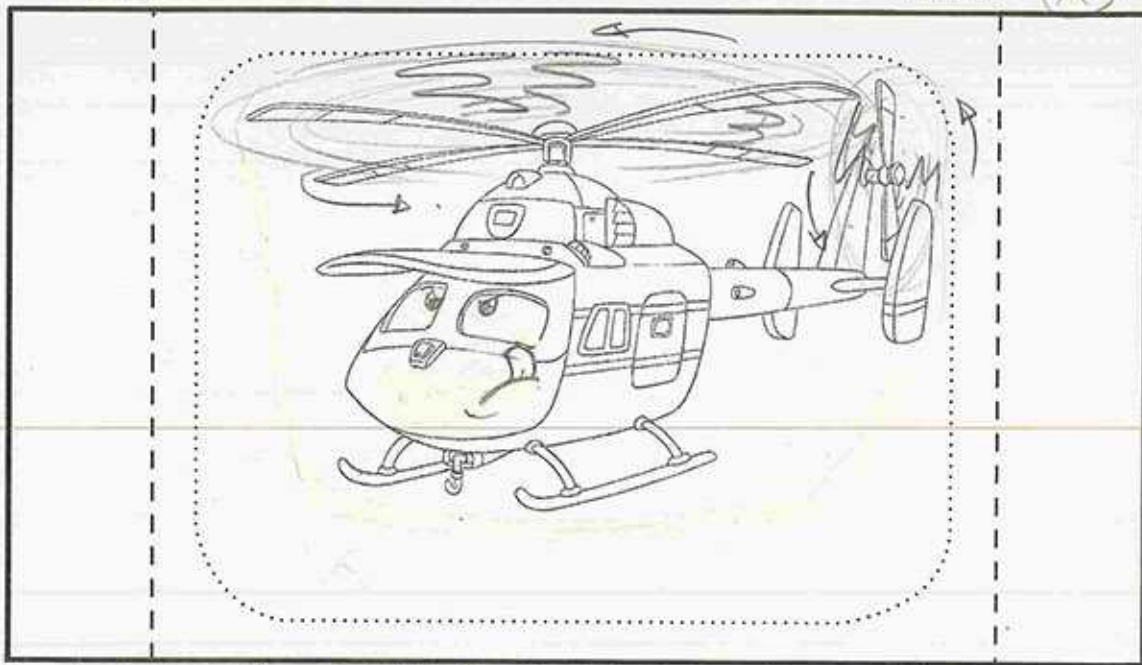

**Action** ANGLE ON SPINNER CONCENTRATING ON KEEPING HIS PROPS SPINNING

**EFX:** (BLUR)

**SFX:** < WHOOOP, WHOOOP ... SLOWING DOWN >

257-786





# FIREHOUSE TALES

©2005 Warner Bros. This Material is the PROPERTY OF WARNER BROS. TELEVISION ANIMATION. It is unpublished and must not be taken from the studio, duplicated or used in any manner, except for production purposes, and may not be sold or transferred.

Sc. 26 (CONT'D)

Panel B

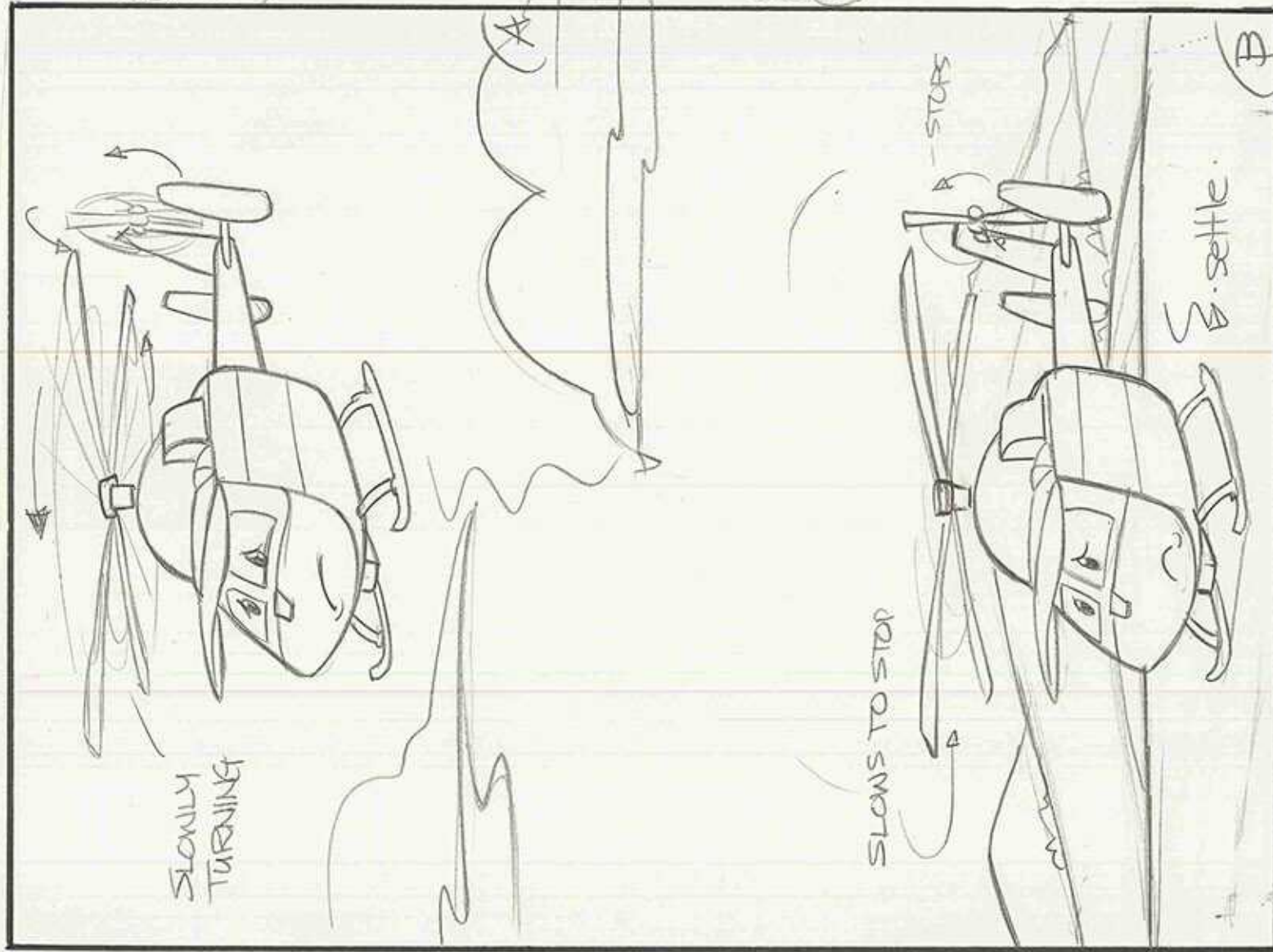

SPINNERS' PROPS SLOWS DOWN.  
AS HE SETTLES GENTLY HIS BLADES  
STOP SPINNING

SPINNER:  
<SPUUTT, SPUT, SPU >

CUT

WISER: YO

AND FOR THOSE WHO USUALLY  
SPENT THEIR DAYS IN THE AIR,  
THE GAS SHORTAGE HAD THEM STUCK  
ON THE GROUND.

257-786





# FIREHOUSE TALES

©2005 Warner Bros. This Material is the PROPERTY OF WARNER BROS. TELEVISION ANIMATION. It is unpublished and must not be taken from the studio, duplicated or used in any manner, except for production purposes, and may not be sold or transferred.

Sc. 27

Panel

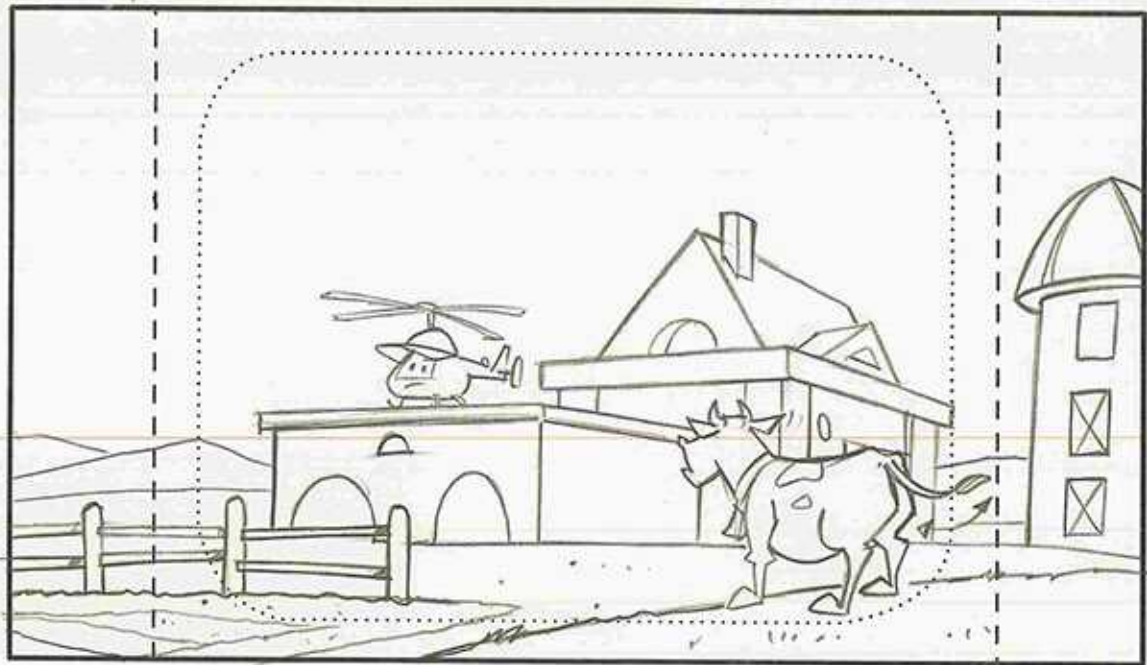

CUT

**Action** EXT. FARM - DAY.  
WIDE ON FLAT TOPPED BARN. SPINNER LOOKS SAD.  
AS A COW LOOKS ON.

CUT

**Dialogue** ⚠️ COW: <MOOO!>

⑳ WISER: (VO)  
"OR CLOSE TO IT."

Sc. 28

Panel

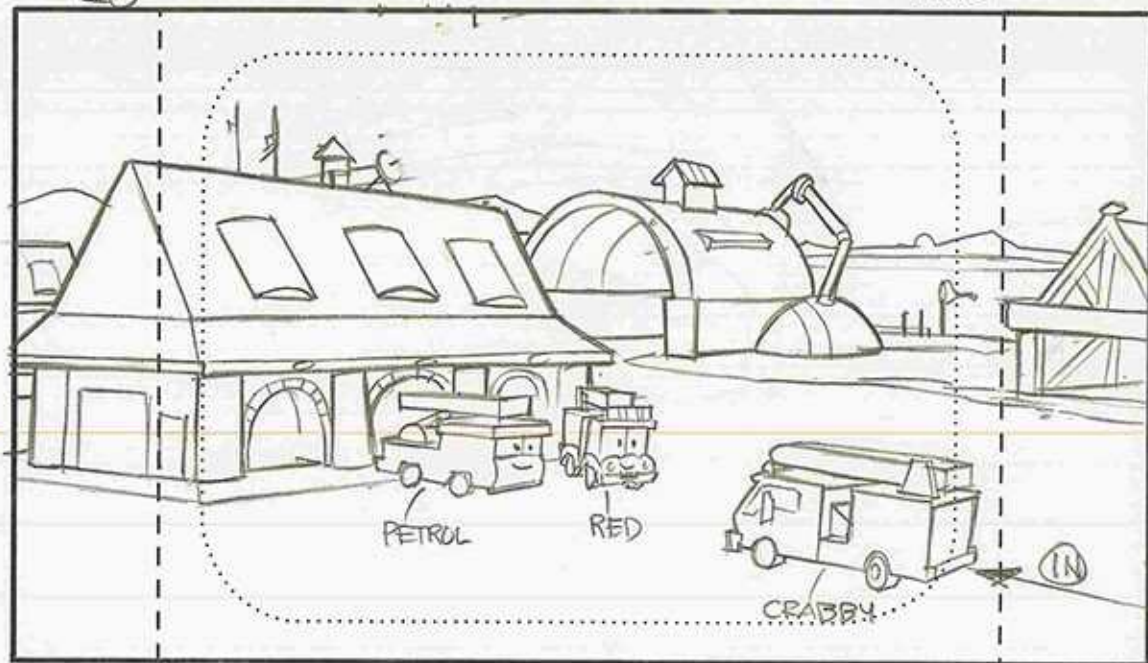

**Action** EXT. SENIOR DORM - REAR VIEW - DAY.  
CRABBY DRIVES TOWARDS THE WAITING PETROL & RED.

CUT

㉑ WISER: (VO)  
"IT WASN'T LONG BEFORE OUR TRUCKS  
STARTED TO HAVE PROBLEMS ..."

257-786





# FIREHOUSE TALES

©2005 Warner Bros. This Material is the PROPERTY OF WARNER BROS. TELEVISION ANIMATION. It is unpublished and must not be taken from the studio, duplicated or used in any manner, except for production purposes, and may not be sold or transferred.

Sc. 29.

Panel A

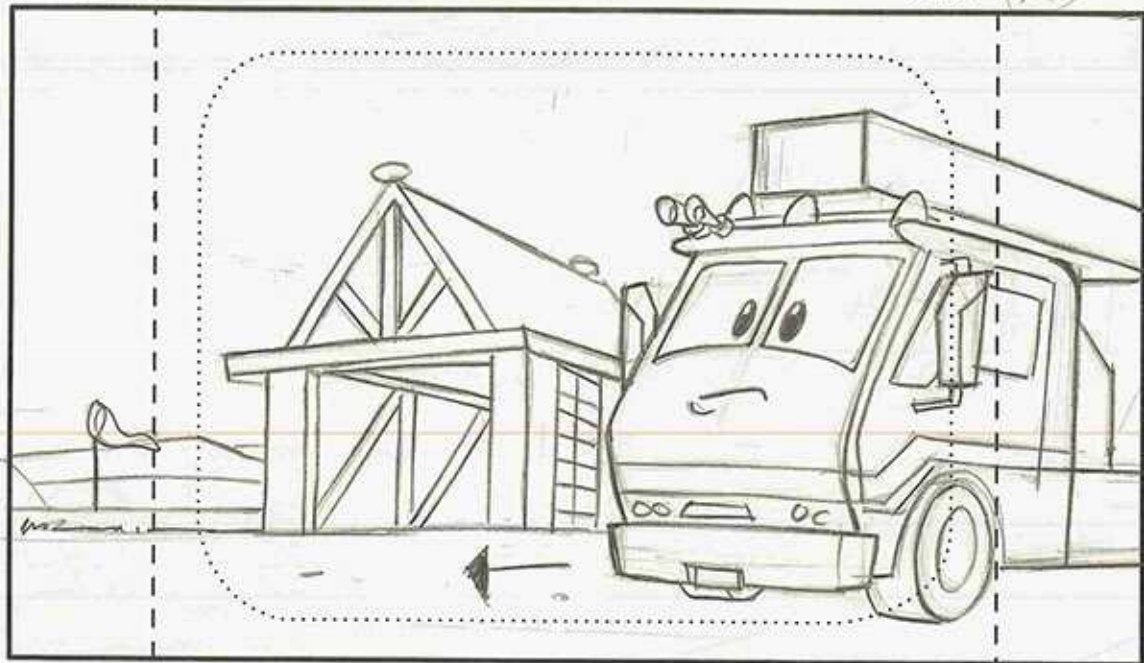

Sc. CONTD

Panel B

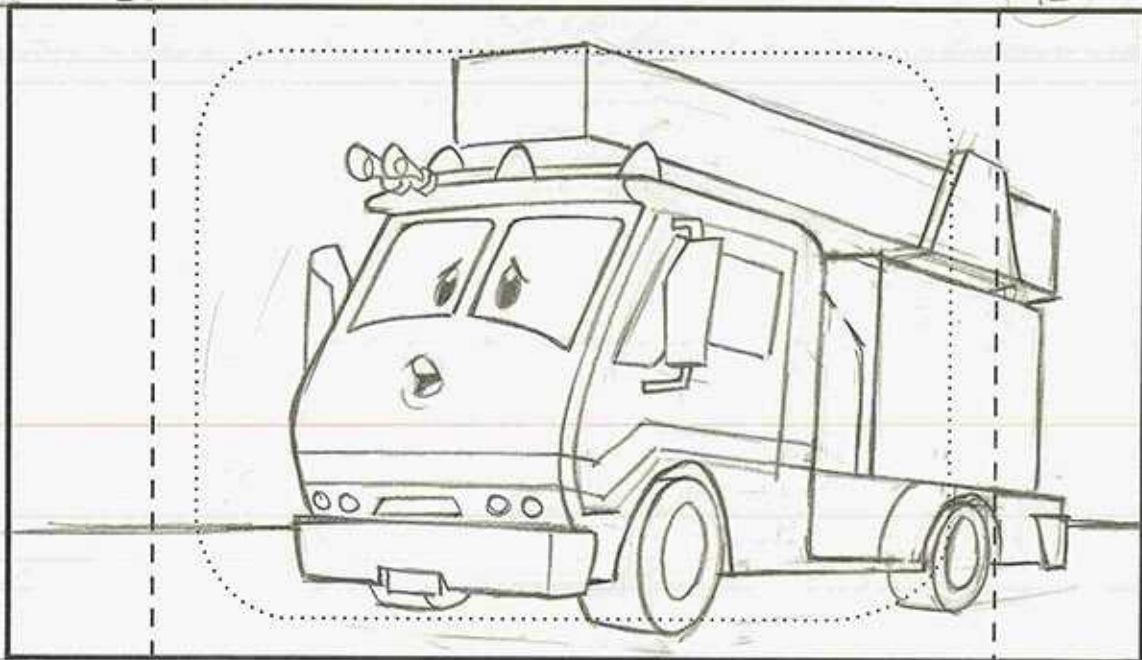

Dialogue Action

ANGLE ON CRABBY -

SFX: (ENGINE)

(21) WISER: (YO) (CONTD)

.. OF THEIR OWN.

Dialogue Action

CRABBY'S ENGINE DIES. HE ROLLS TO A STOP.

SFX: (ENGINE SPUTTER)

(22) CRABBY:

UH OH.





# FIREHOUSE TALES

©2005 Warner Bros. This Material is the PROPERTY OF WARNER BROS. TELEVISION ANIMATION. It is unpublished and must not be taken from the studio, duplicated or used in any manner, except for production purposes, and may not be sold or transferred.

Sc. 29 CONTD.

Panel C

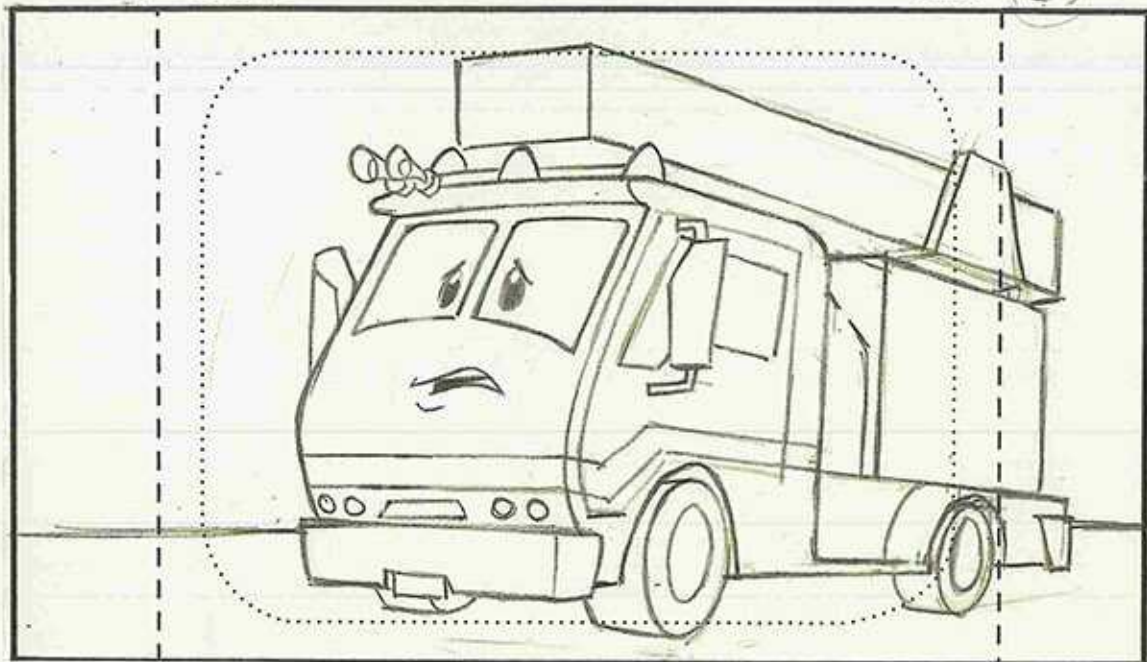

Dialogue Action

22 CRABBY:

NOT EVEN ANY FUMES LEFT.

CUT

Sc. 30

Panel

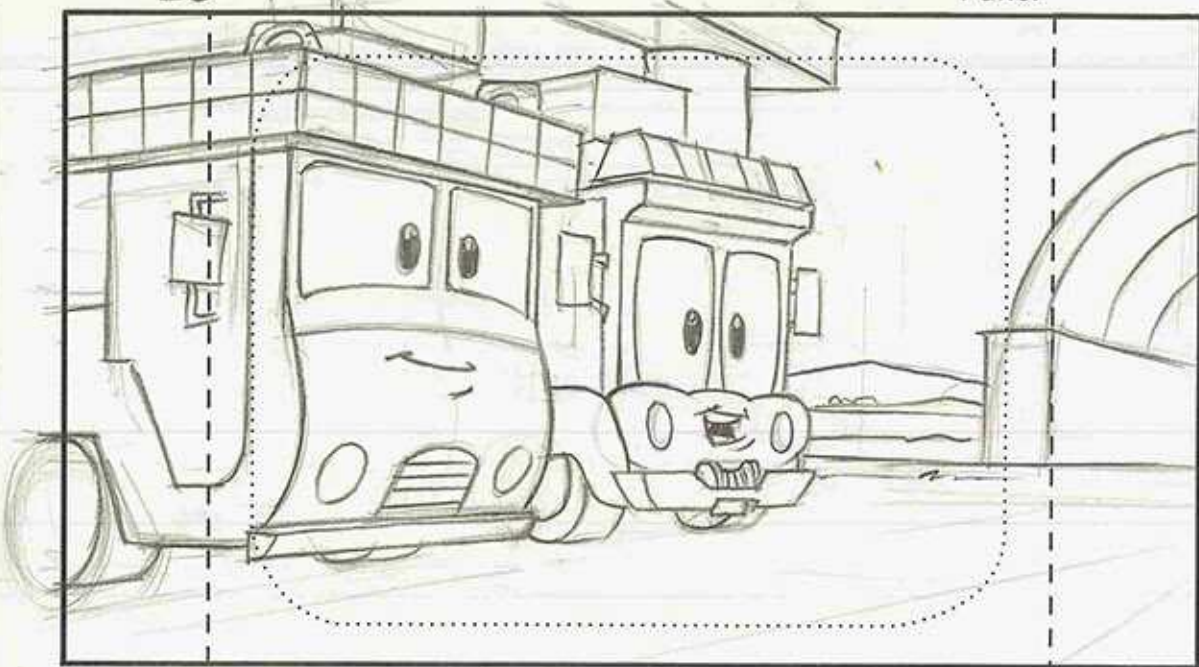

Dialogue Action

ANGLE ON RED & CRABBY.

23 RED:

WE CAN HELP YOU.

257-786





# FIREHOUSE TALES

©2005 Warner Bros. This Material is the PROPERTY OF WARNER BROS. TELEVISION ANIMATION. It is unpublished and must not be taken from the studio, duplicated or used in any manner, except for production purposes, and may not be sold or transferred.

Sc. 30 CONTD.

Panel (B)

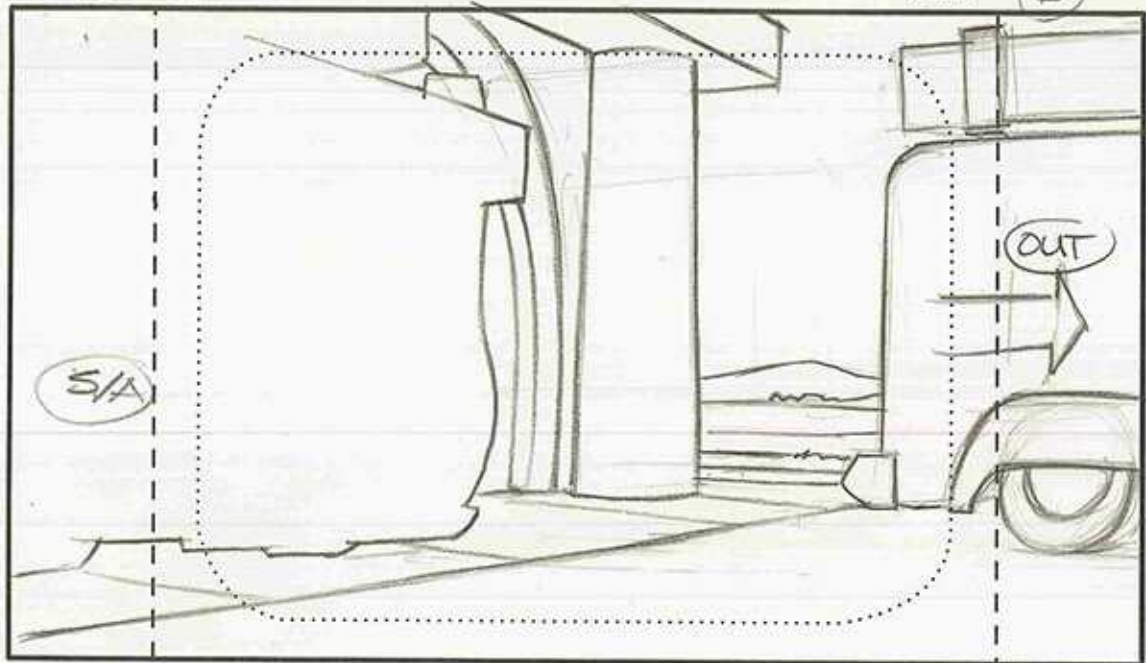

Dialogue Action

RED DRIVES OUT.

Sc. CONTD.

Panel (C)

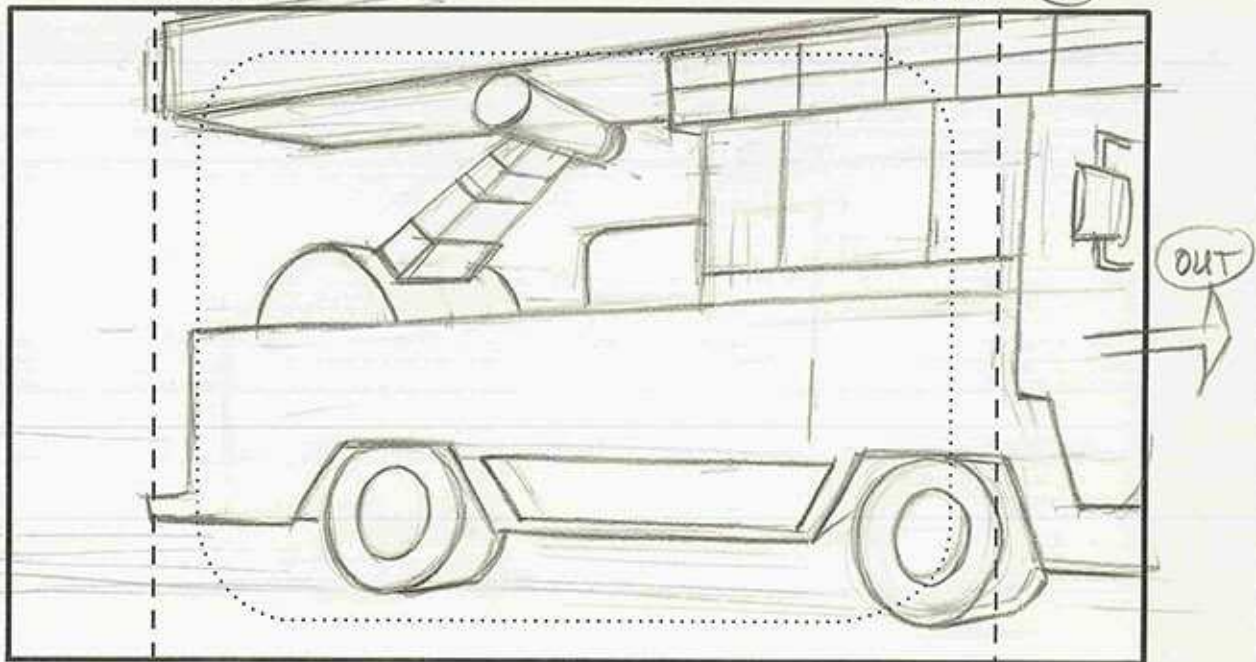

Dialogue Action

FOLLOWED BY PETROL. (CUT ON ACTION)





# FIREHOUSE TALES

©2005 Warner Bros. This Material is the PROPERTY OF WARNER BROS. TELEVISION ANIMATION. It is unpublished and must not be taken from the studio, duplicated or used in any manner, except for production purposes, and may not be sold or transferred.

Sc. 31

Panel (A)

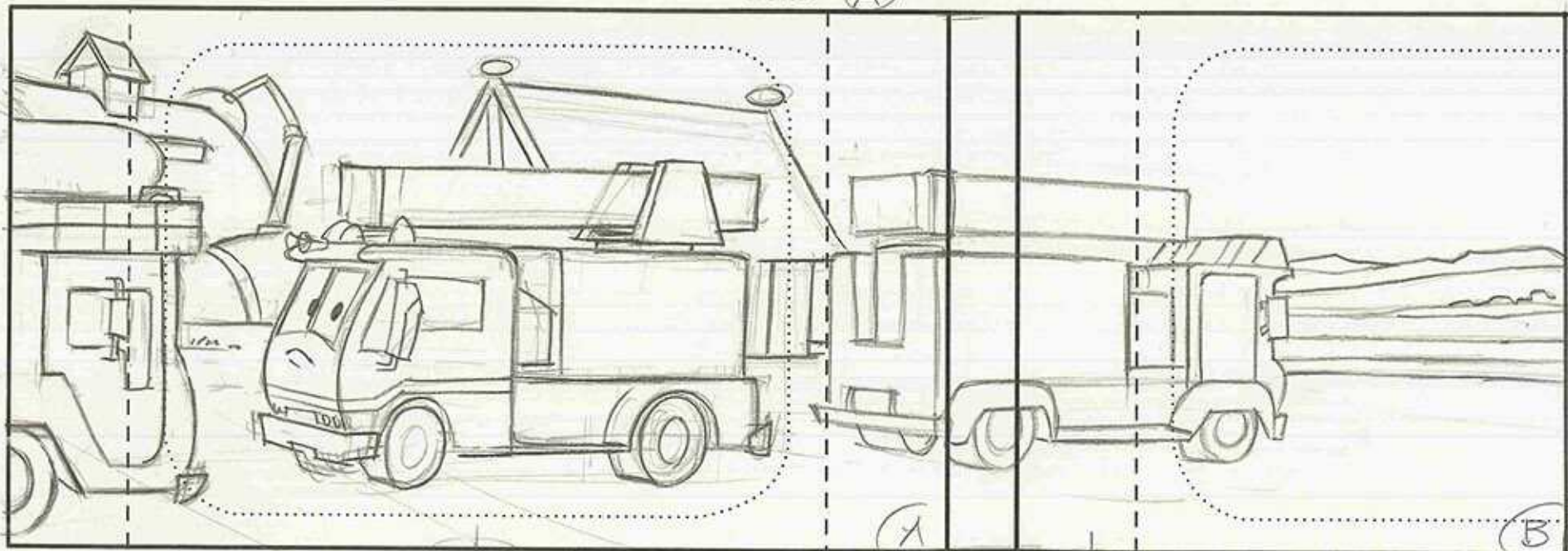

Dialogue Action

ANGLE ON: CRABBY. PETROL DRIVES PAST HIM AND POSITIONS HIMSELF BESIDE RED, BEHIND CRABBY.

Dialogue Action

STOP





# FIREHOUSE TALES

©2005 Warner Bros. This Material is the PROPERTY OF WARNER BROS. TELEVISION ANIMATION. It is unpublished and must not be taken from the studio, duplicated or used in any manner, except for production purposes, and may not be sold or transferred.

Sc. 31 CONTD.

Panel B

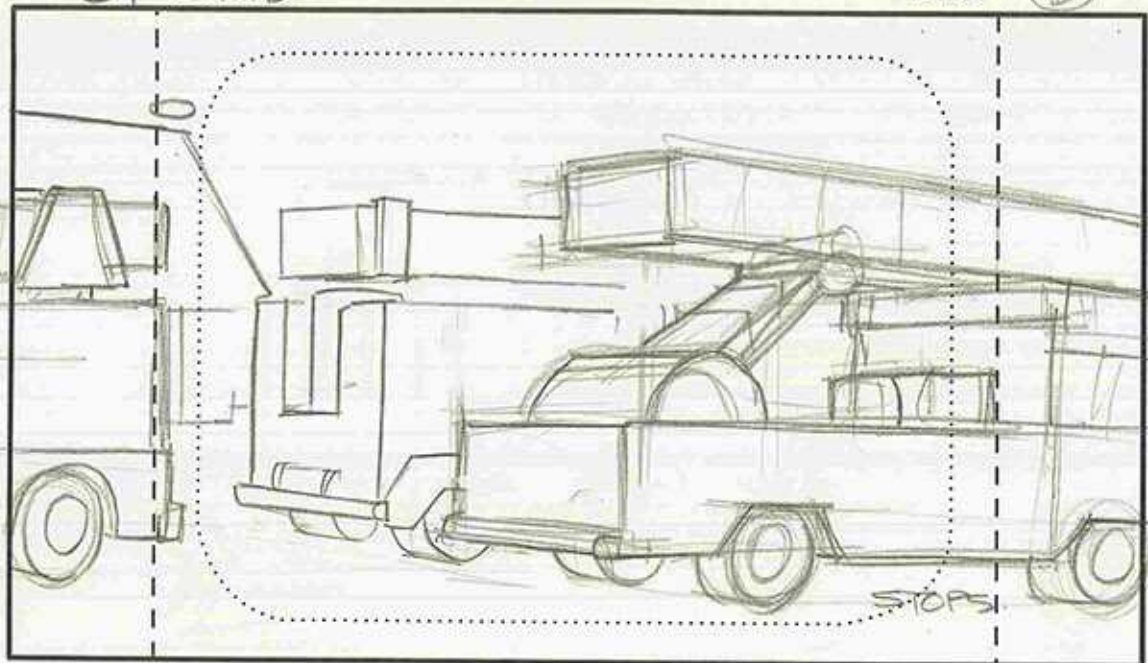

**Dialogue Action** PETROL STOPS HIS ENGINE DIES.

SFX: <ENGINE SPITTER!>

CUT

Sc. 32

Panel A

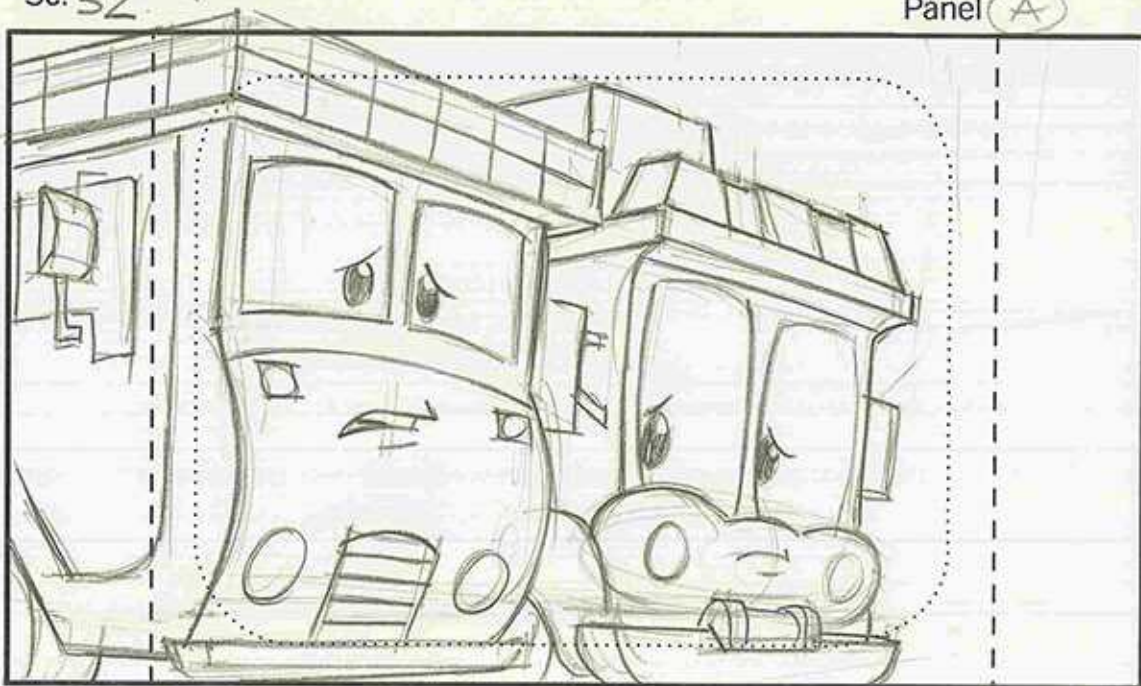

**Dialogue Action** CLOSE ON PETROL & RED.

(24) PETROL: (CONCERNED)

THIS ISN'T GOOD.





# FIREHOUSE TALES

©2005 Warner Bros. This Material is the PROPERTY OF WARNER BROS. TELEVISION ANIMATION. It is unpublished and must not be taken from the studio, duplicated or used in any manner, except for production purposes, and may not be sold or transferred.

Sc. 32 CONTD.

Panel (B)

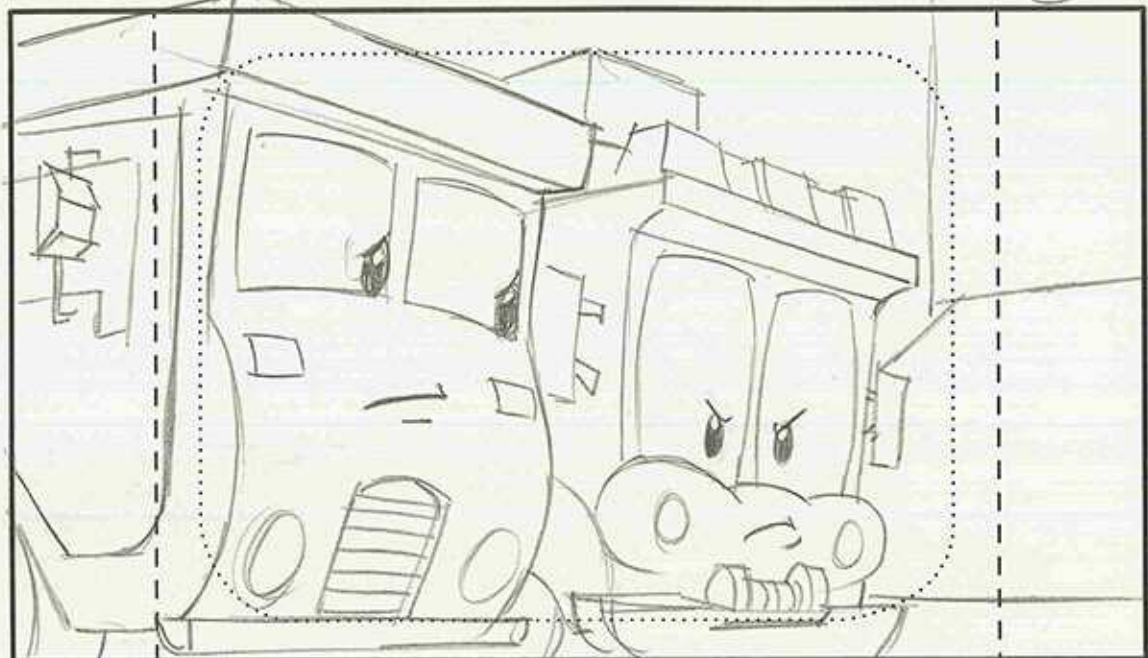

RED GETS A DETERMINED LOOK ON HIS FACE

Dialogue Action

Sc. CONTD.

Panel (C)

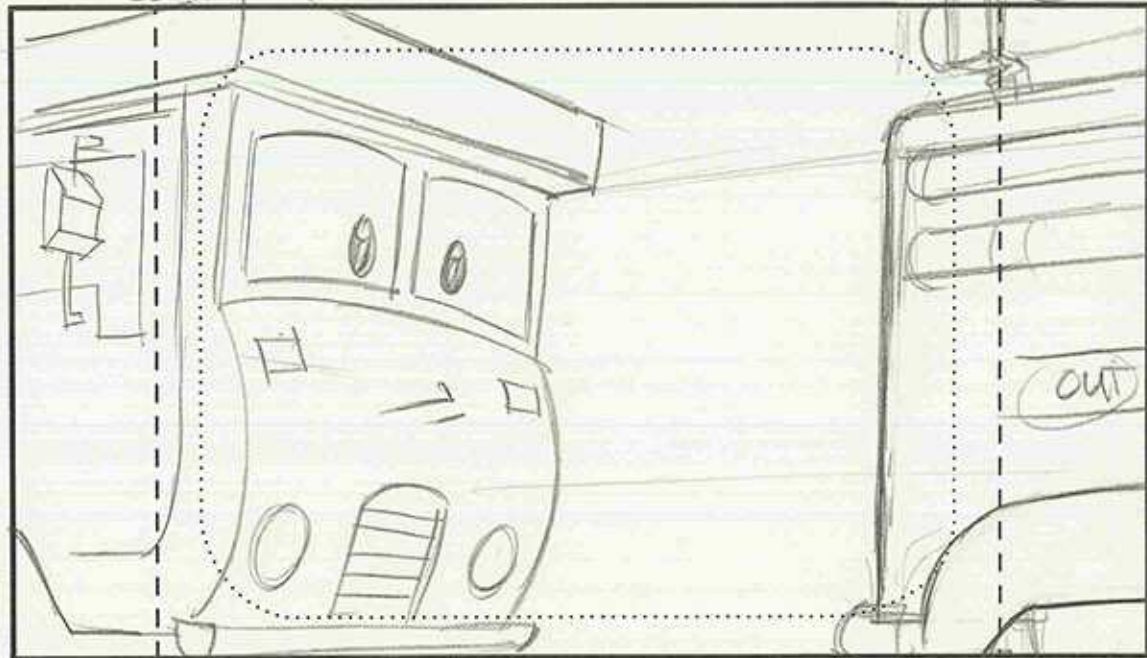

RED DRIVES FORWARD & CUT

Dialogue Action

CUT





# FIREHOUSE TALES

©2005 Warner Bros. This Material is the PROPERTY OF WARNER BROS. TELEVISION ANIMATION. It is unpublished and must not be taken from the studio, duplicated or used in any manner, except for production purposes, and may not be sold or transferred.

Sc. 33

Panel (A)

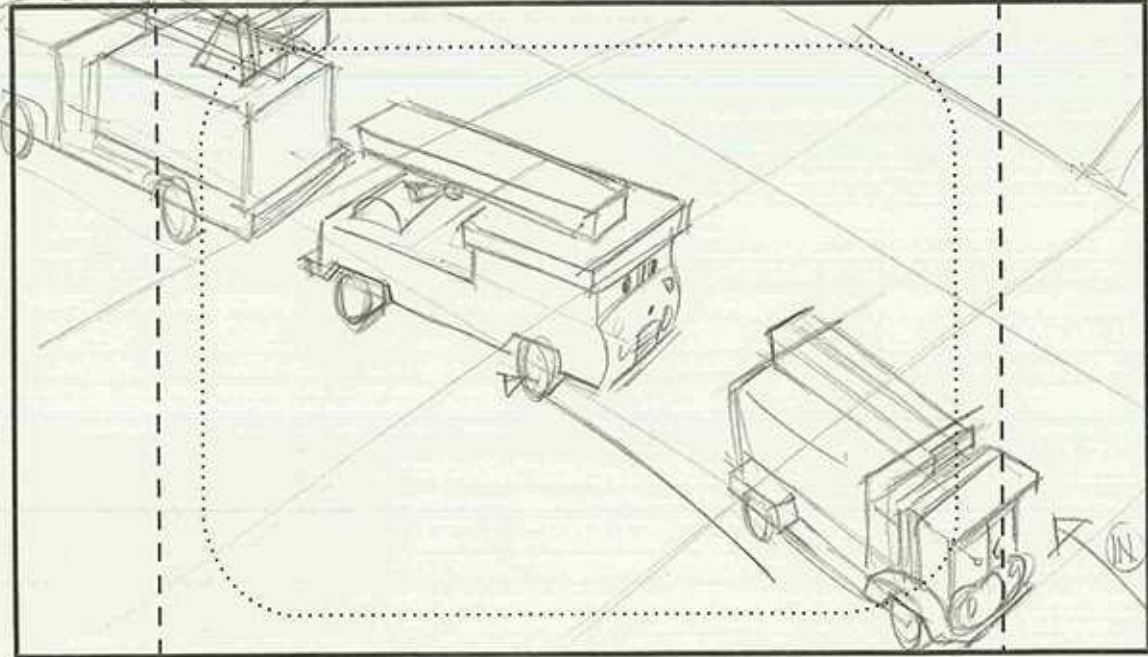

**Dialogue Action** EXT FIREHOUSE DOWN ANGLE ON COURTYARD  
RED BACKS INTO SCENE

Sc. CONTD

Panel (B)

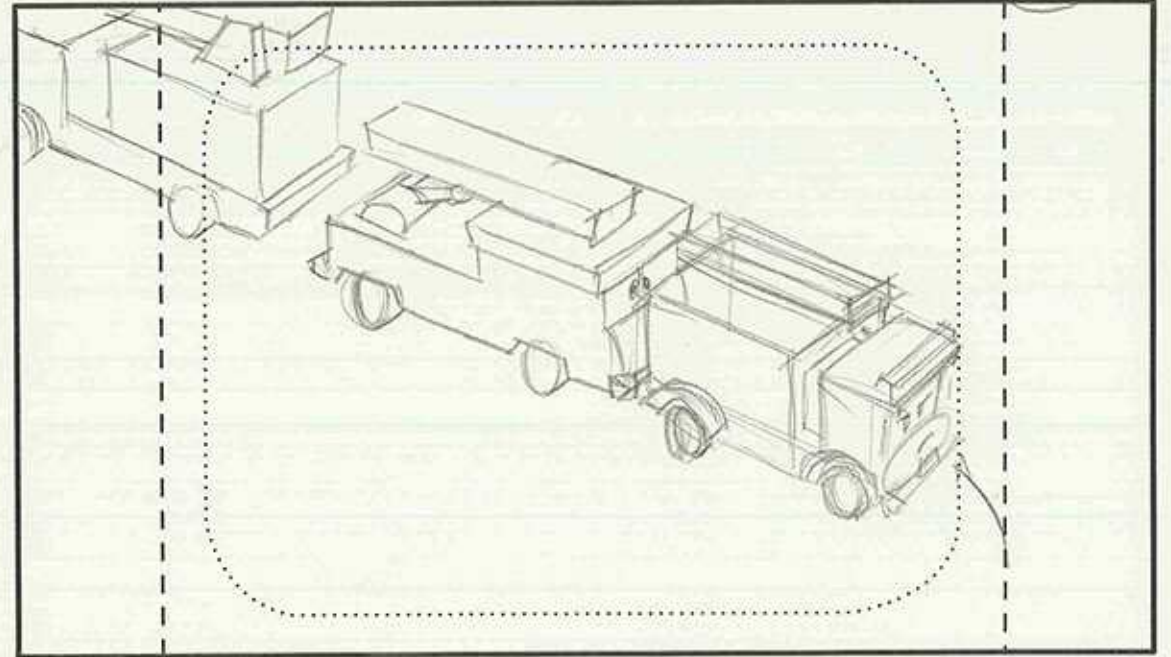

**Dialogue Action** RED BACKS UP IN FRONT OF PETROL. HE'S GOING TO TRY AND PUSH BOTH PETROL AND CRABBY.

CUT





# FIREHOUSE TALES

©2005 Warner Bros. This Material is the PROPERTY OF WARNER BROS. TELEVISION ANIMATION. It is unpublished and must not be taken from the studio, duplicated or used in any manner, except for production purposes, and may not be sold or transferred.

Sc. 3A

Panel A

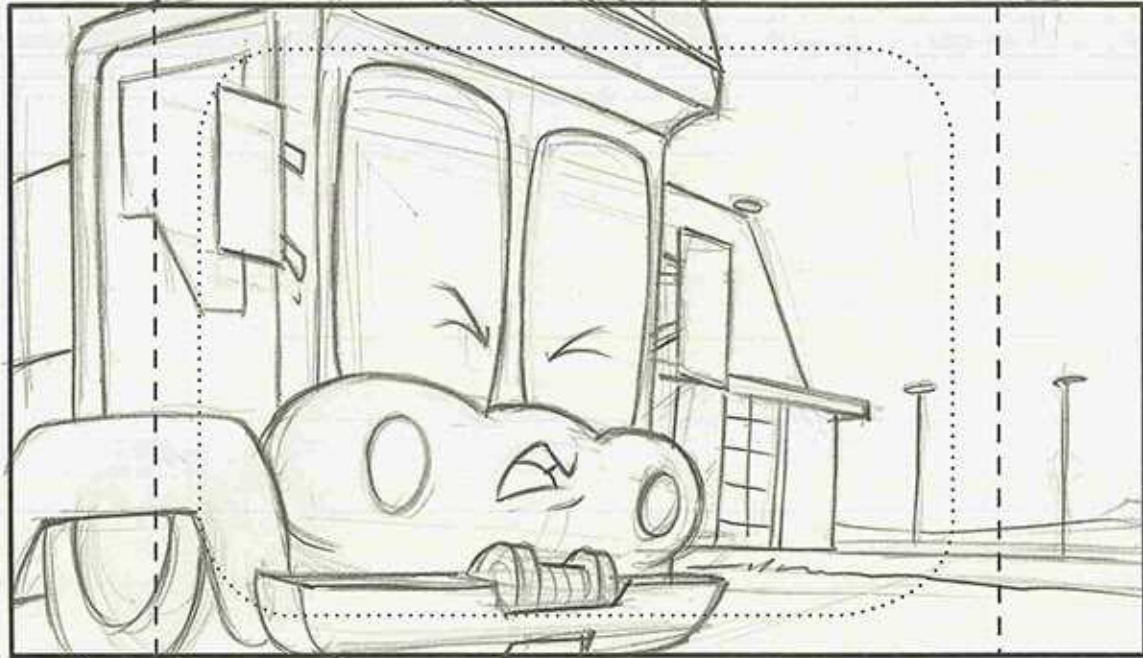

CUT

Dialogue Action

CLOSE ON A STRAINING RED.

(25) RED: (STRAINING)

DON'T WORRY, GUYS... I CAN PUSH YA...

Sc. CONTD -

Panel B

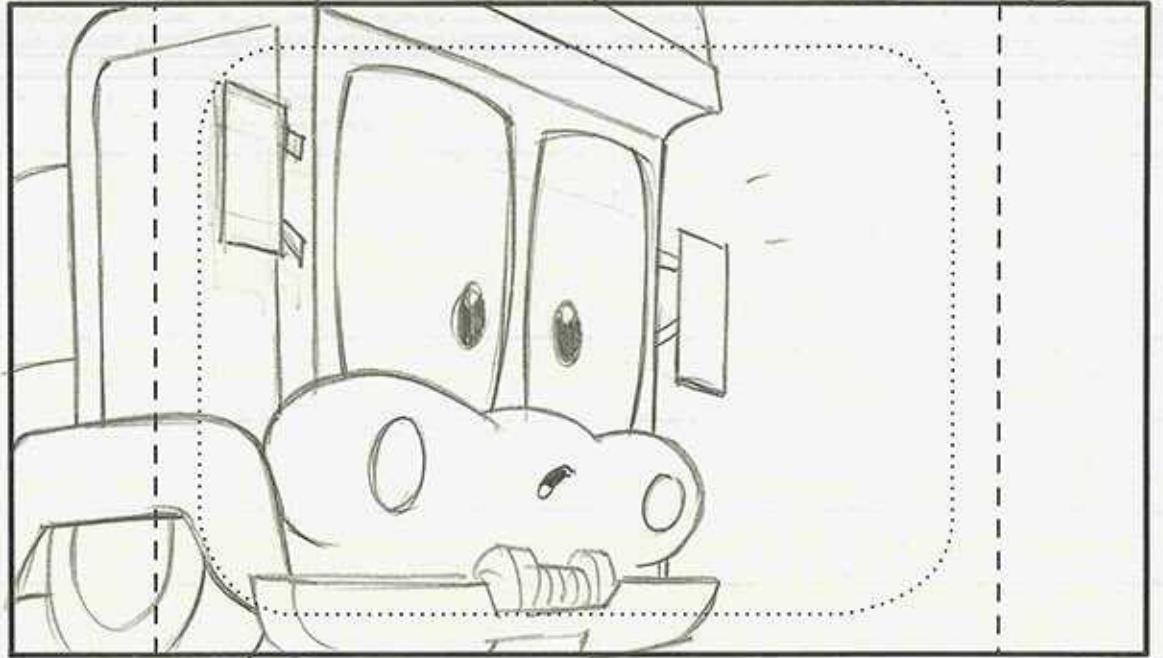

Dialogue Action

RED'S ENGINE SPUTTERS & DIES.

SFX: <ENGINE SPATTER>





# FIREHOUSE TALES

©2005 Warner Bros. This Material is the PROPERTY OF WARNER BROS. TELEVISION ANIMATION. It is unpublished and must not be taken from the studio, duplicated or used in any manner, except for production purposes, and may not be sold or transferred.

Sc. 34 (CONTD.)

Panel (C)

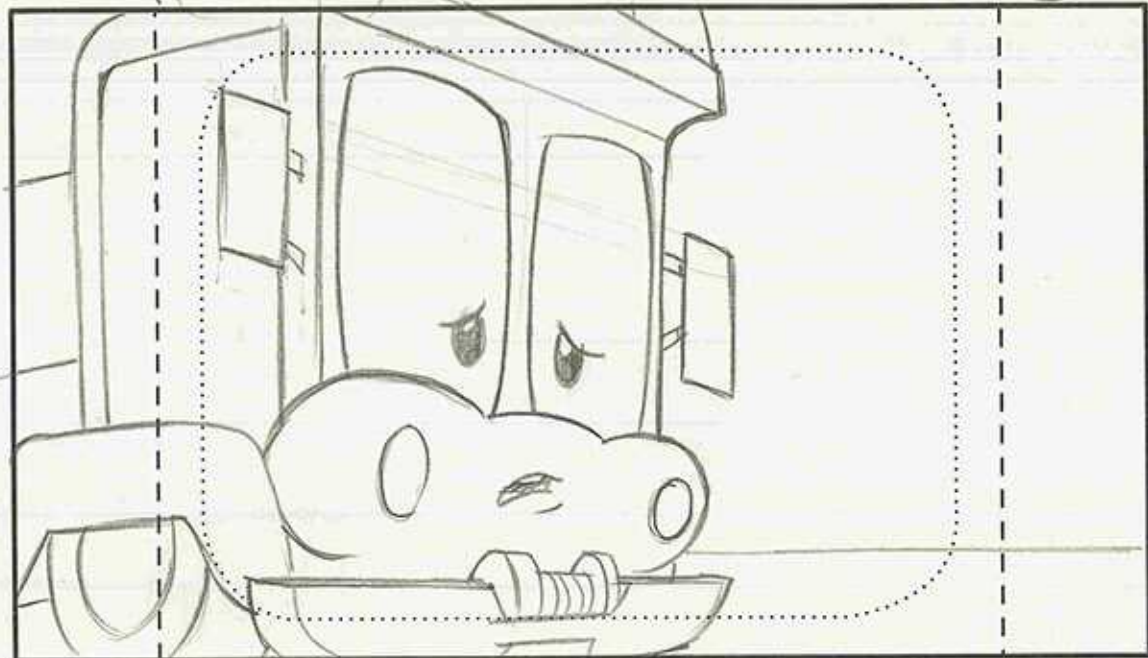

Dialogue Action

(25) RED: (CONTD)  
WELL, I COULD'VE...

Sc. CONTD

Panel (D)

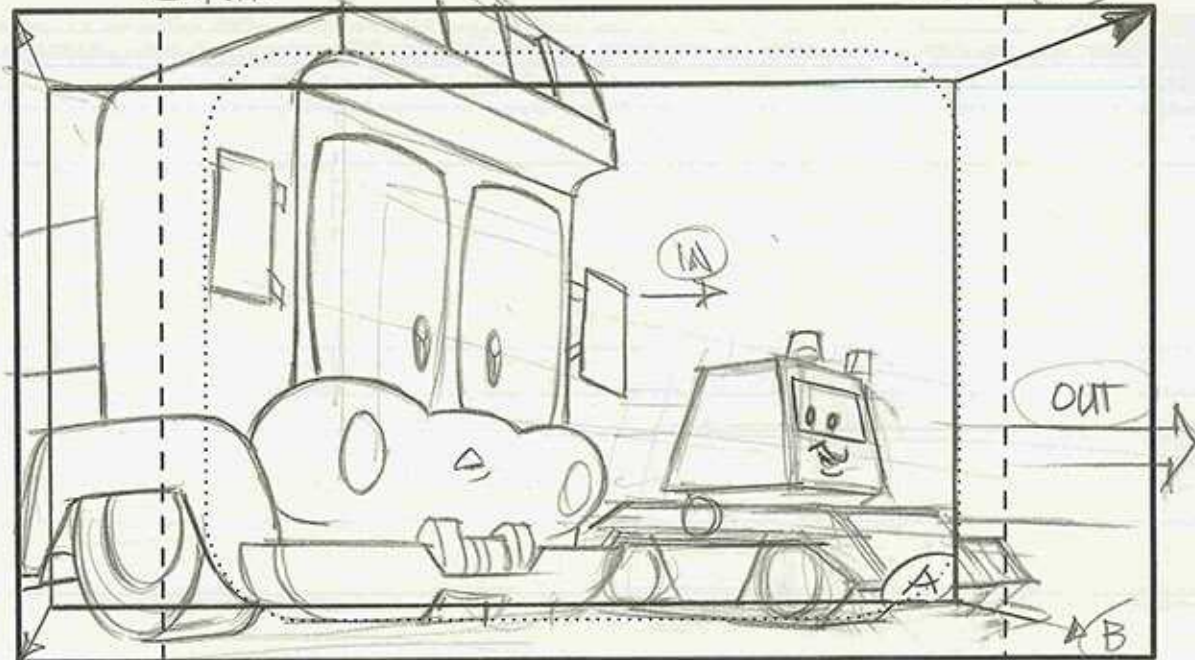

Dialogue Action

TECH ZIPS IN & PAST RED, WHO IS STARTLED.  
TRUCK OUT (A) → (B)

(26) TECH:  
Hi, BOYS.

CUT  
257-786





# FIREHOUSE TALES

©2005 Warner Bros. This Material is the PROPERTY OF WARNER BROS. TELEVISION ANIMATION. It is unpublished and must not be taken from the studio, duplicated or used in any manner, except for production purposes, and may not be sold or transferred.

Sc. 35

Panel

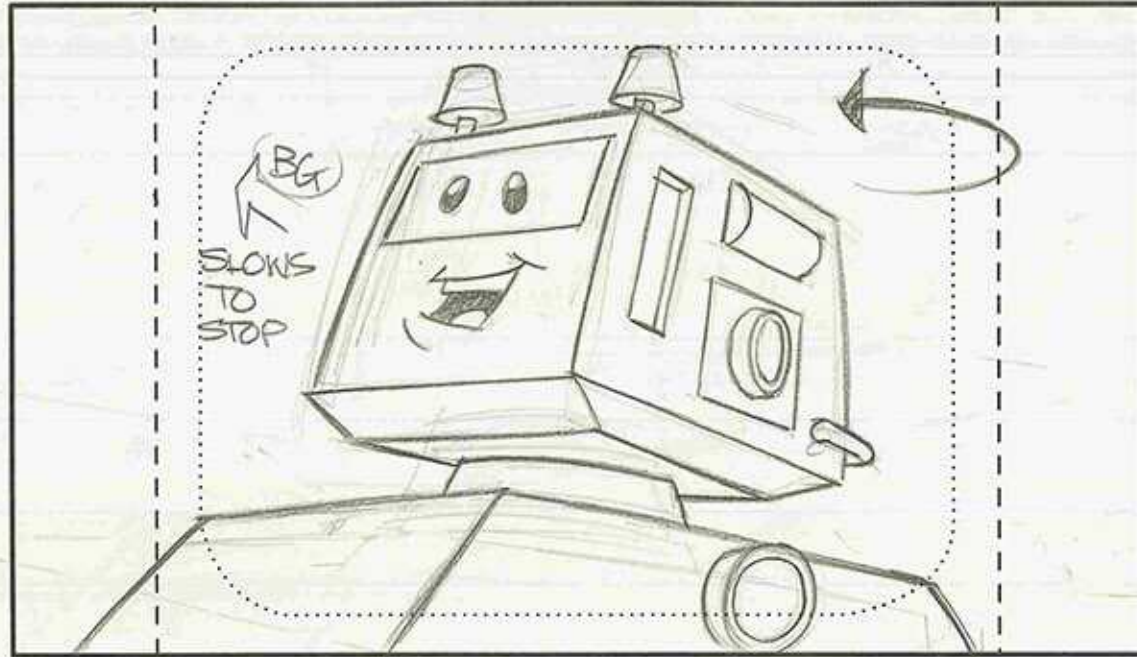

CUT

Dialogue Action

ANGLE ON TECH HE SWIVELS

(26) TECH: (CONTD)

LOOKS LIKE YOU COULD USE A  
PICK-ME-UP.

CUT

Sc. 36

Panel

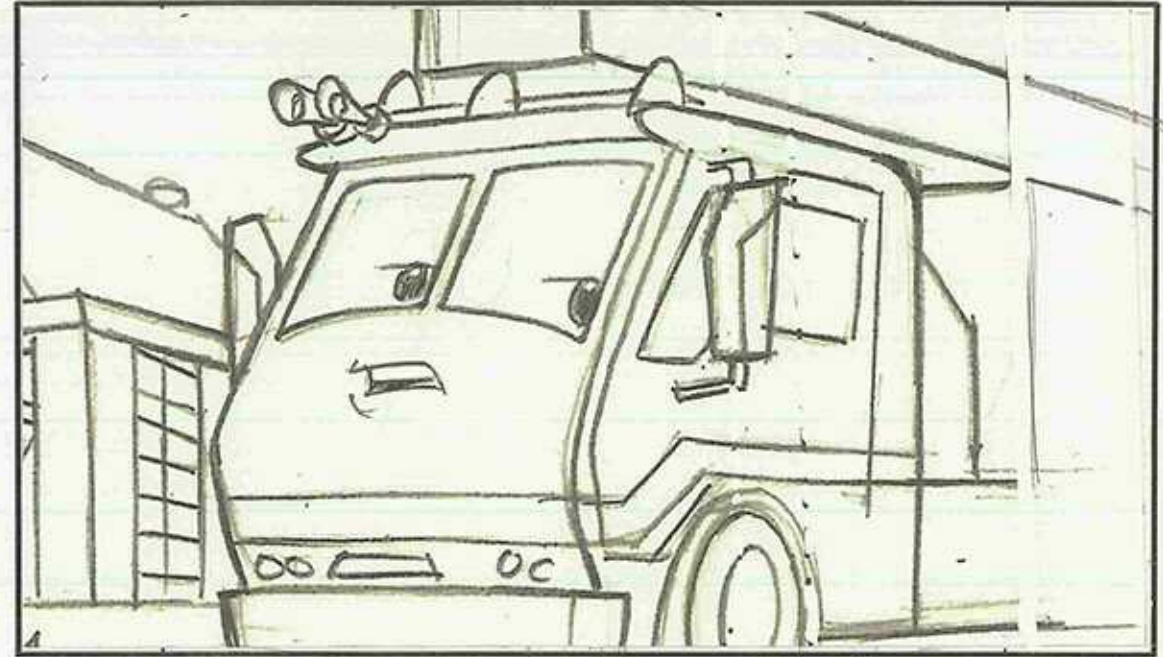

CUT

Dialogue Action

CLOSE ON CRABBY.

(27) CRABBY:

OR SOME GAS.





# FIREHOUSE TALES

©2005 Warner Bros. This Material is the PROPERTY OF WARNER BROS. TELEVISION ANIMATION. It is unpublished and must not be taken from the studio, duplicated or used in any manner, except for production purposes, and may not be sold or transferred.

Sc. 37

SA 32 Panel

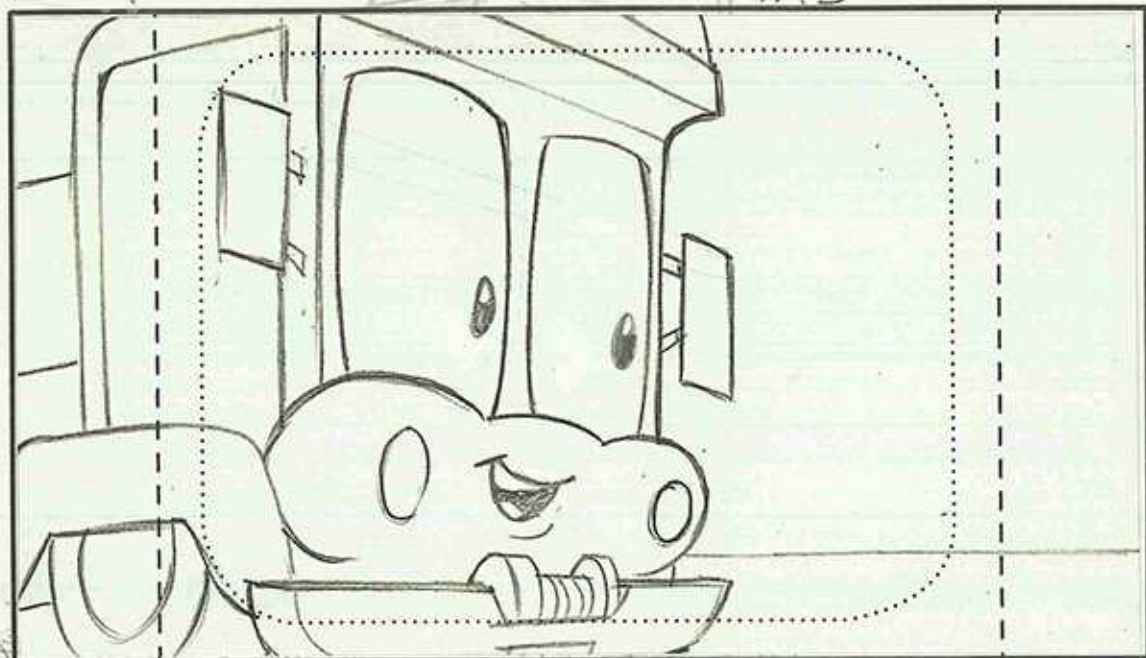

CUT

Dialogue Action

CLOSE ON RED.

(28) RED:

DO YOU HAVE ANY, TECH?

Sc. 38

Panel

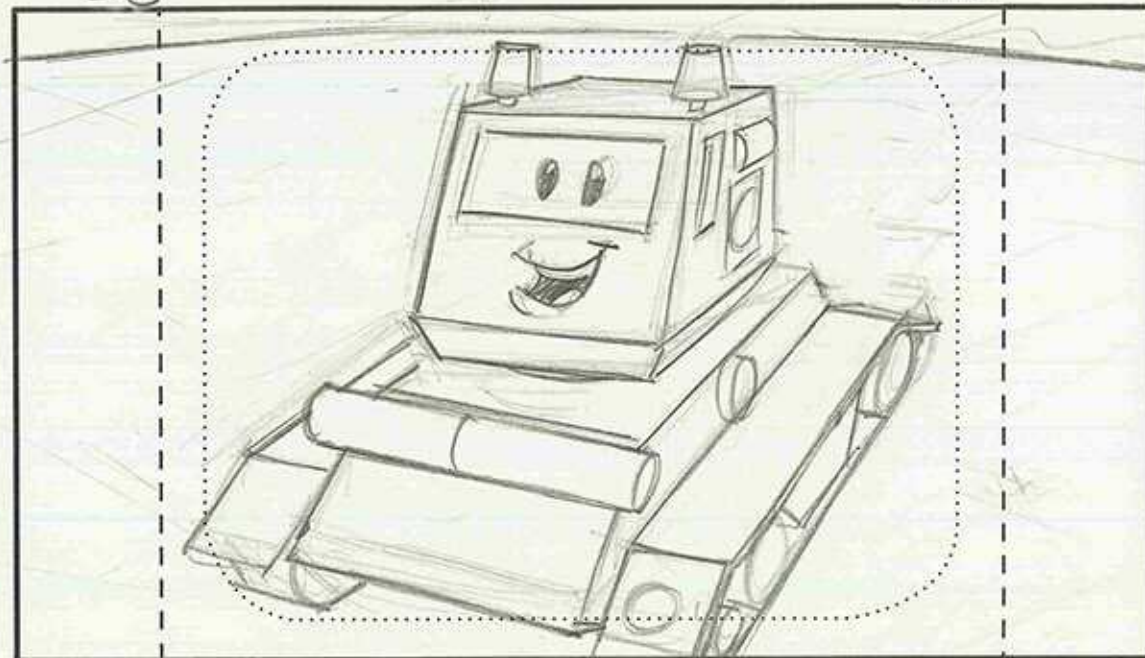

CUT

Dialogue Action

ANGLE ON TECH

(29) TECH:

NOPE. DON'T NEED ANY.





# FIREHOUSE TALES

©2005 Warner Bros. This Material is the PROPERTY OF WARNER BROS. TELEVISION ANIMATION. It is unpublished and must not be taken from the studio, duplicated or used in any manner, except for production purposes, and may not be sold or transferred.

Sc. 38 CONTD.

Panel (B)

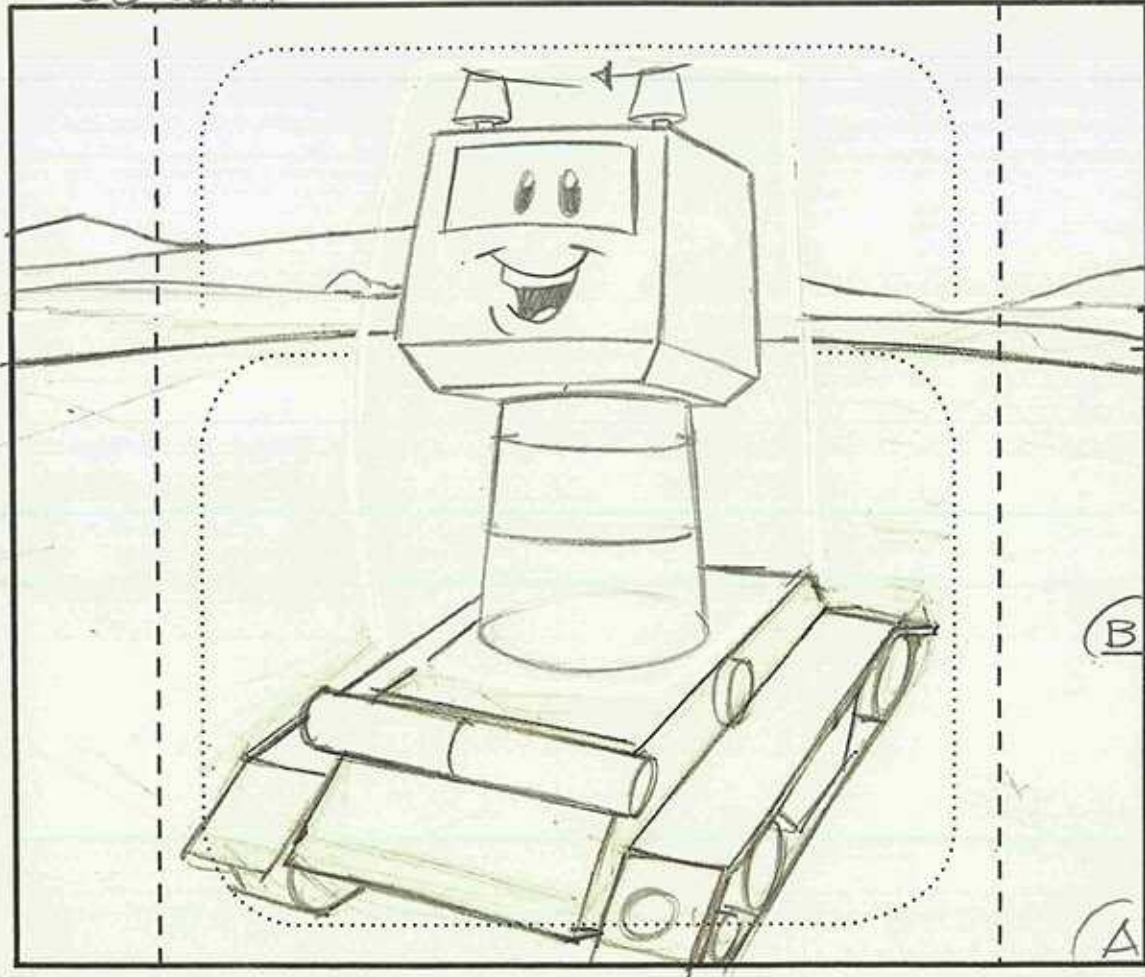

(B)

(A)

ction

Sc. CONTD.

Panel (C)

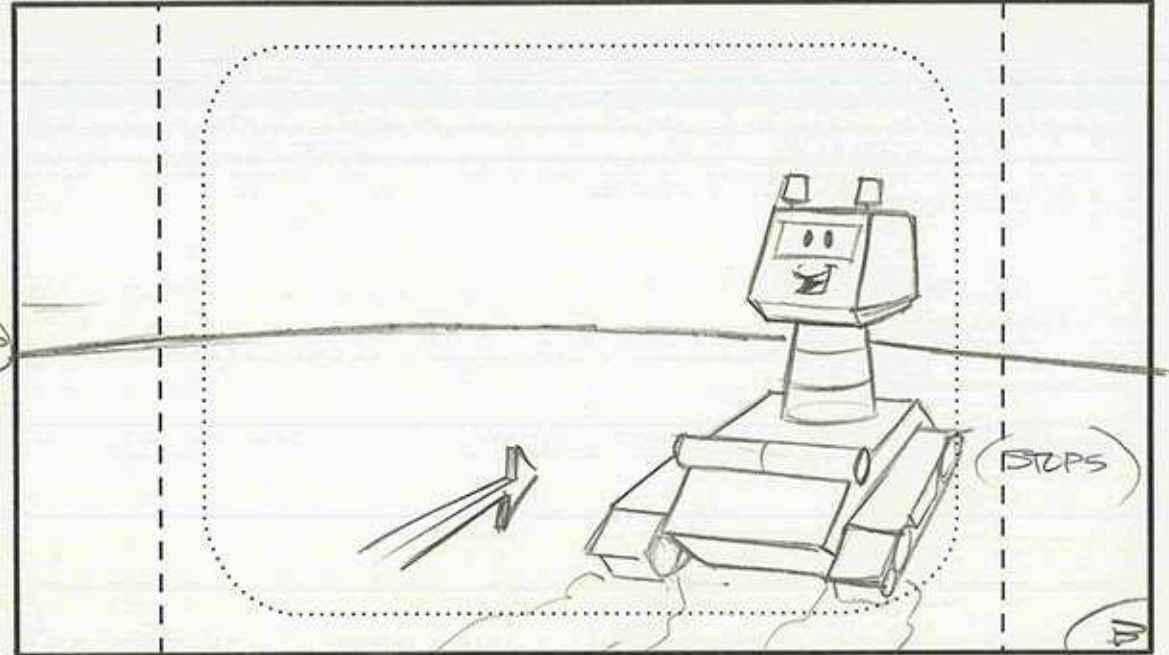

START  
Dialogue Action

PAN W/ANIM (A) → (B) AS TECH EXTENDS & SWIVELS HIS NECK. THEN HE DRIVES AWAY.

(CUT)

(29) TECH: (CONTD)

I'M BATTERY-POWERED. A CLEAN MACHINE.

257-786





# FIREHOUSE TALES

©2005 Warner Bros. This Material is the PROPERTY OF WARNER BROS. TELEVISION ANIMATION. It is unpublished and must not be taken from the studio, duplicated or used in any manner, except for production purposes, and may not be sold or transferred.

Sc. 39

Panel A

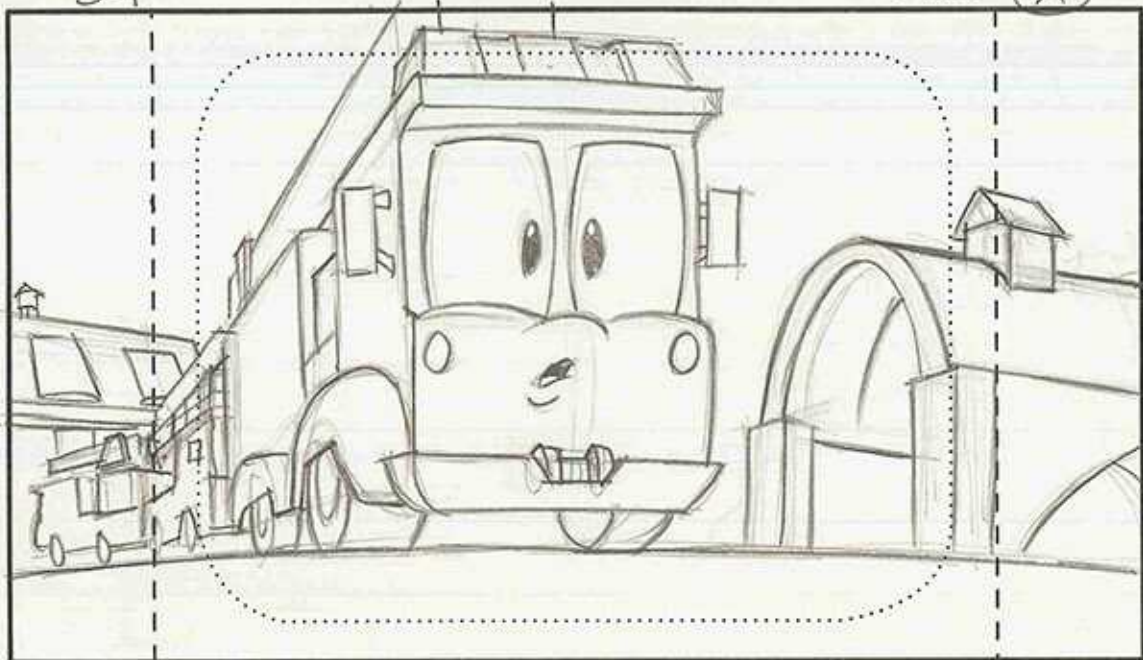

CUT

ANGLE ON RED

Dialogue Action

30 RED: (WORRIED)  
WELL, I WISH WE WERE CLEAN MACHINES,  
BECAUSE IF THERE'S A FIRE ...

Sc.

Panel

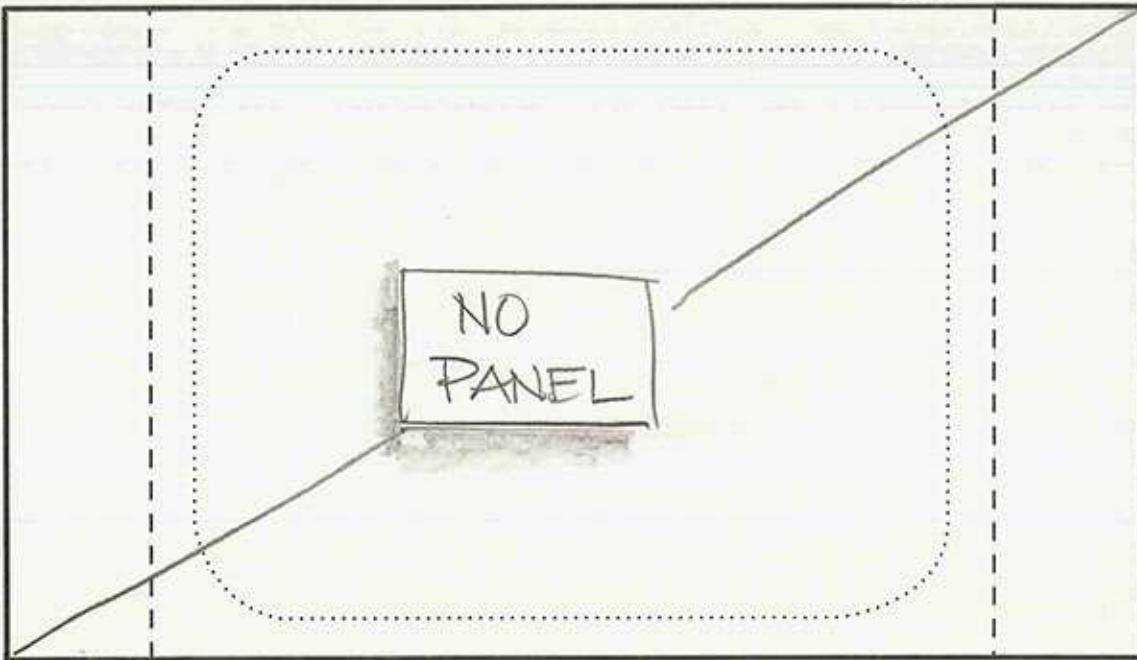

Dialogue Action

SCENE CONT'D ON NEXT PAGE

257-786





# FIREHOUSE TALES

©2005 Warner Bros. This Material is the PROPERTY OF WARNER BROS. TELEVISION ANIMATION. It is unpublished and must not be taken from the studio, duplicated or used in any manner, except for production purposes, and may not be sold or transferred.

Page

39

Sc. 39 CONTD.

Panel (B)

Sc.

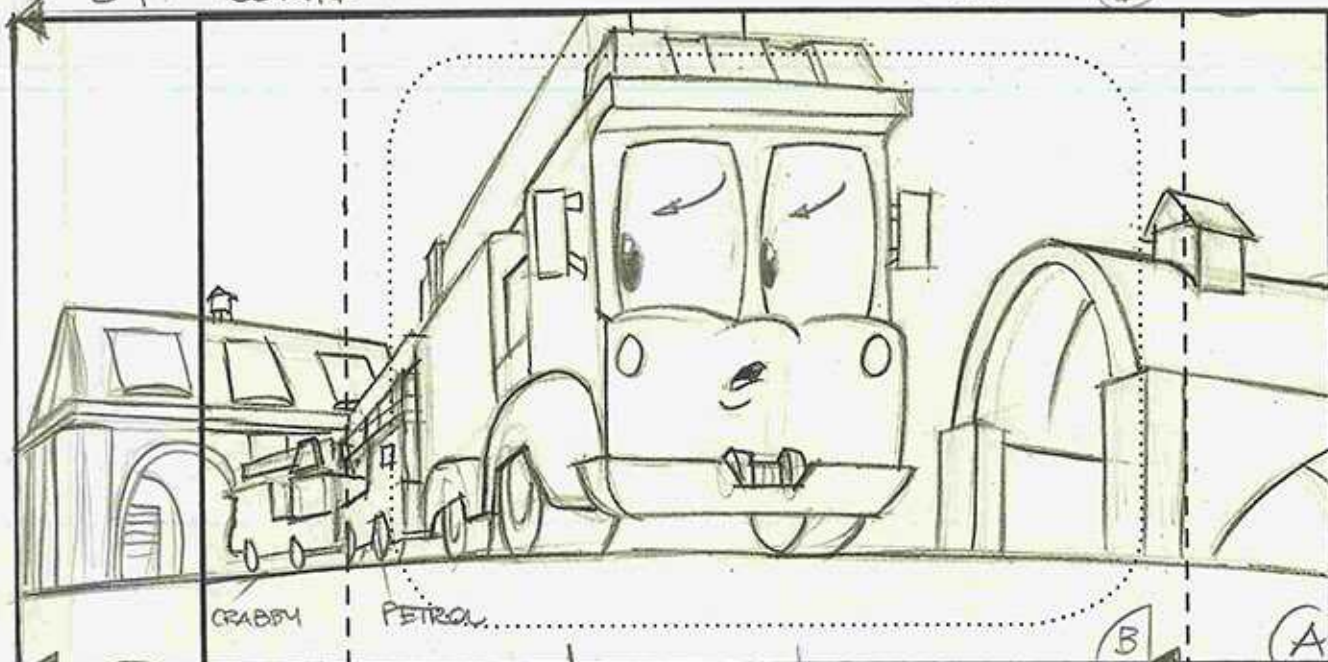

Sc. CONTD

Panel (C)

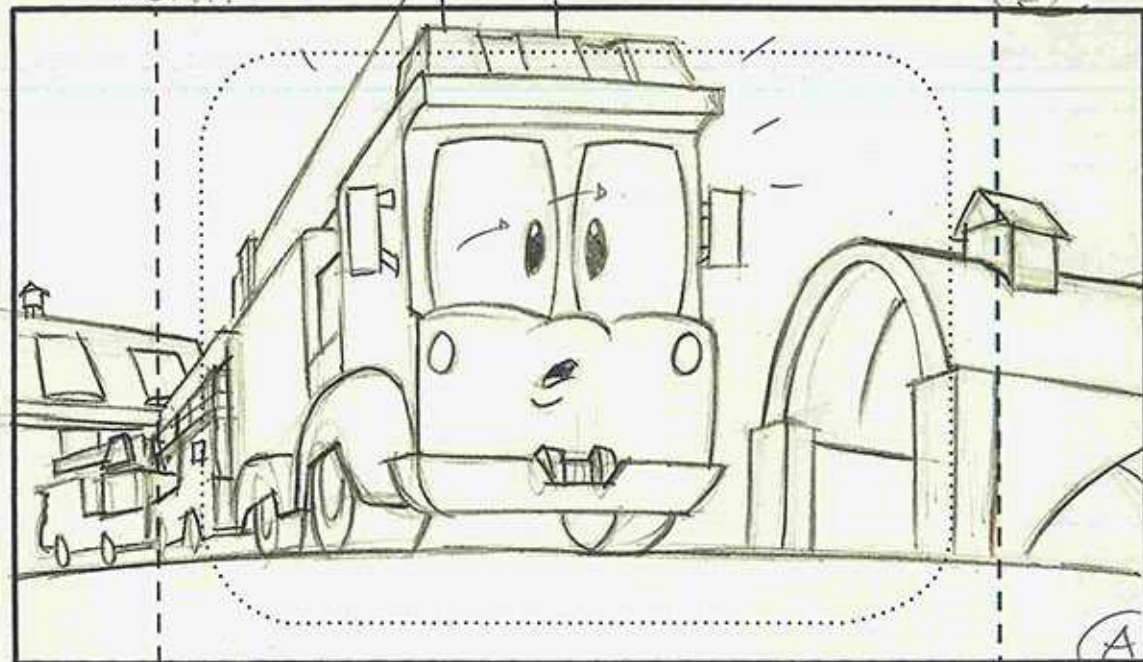

Dialogue Action  
STOP PAN START  
SHIFT W/ANIM (A) → (B) 'CRABBY & PETROL HAVEN'T MOVED

Dialogue (30) RED: (CONTD)  
.. I DON'T KNOW WHAT WE'RE GONNA DO..

Dialogue Action  
SHIFT BACK (B) → (A) TUG'S CALLS FROM O.S. STARTLING RED.

Dialogue (31) TUG: (VO)  
HEY MATEY'S ...

257-786





# FIREHOUSE TALES

©2005 Warner Bros. This Material is the PROPERTY OF WARNER BROS. TELEVISION ANIMATION. It is unpublished and must not be taken from the studio, duplicated or used in any manner, except for production purposes, and may not be sold or transferred.

Sc. 40

Panel

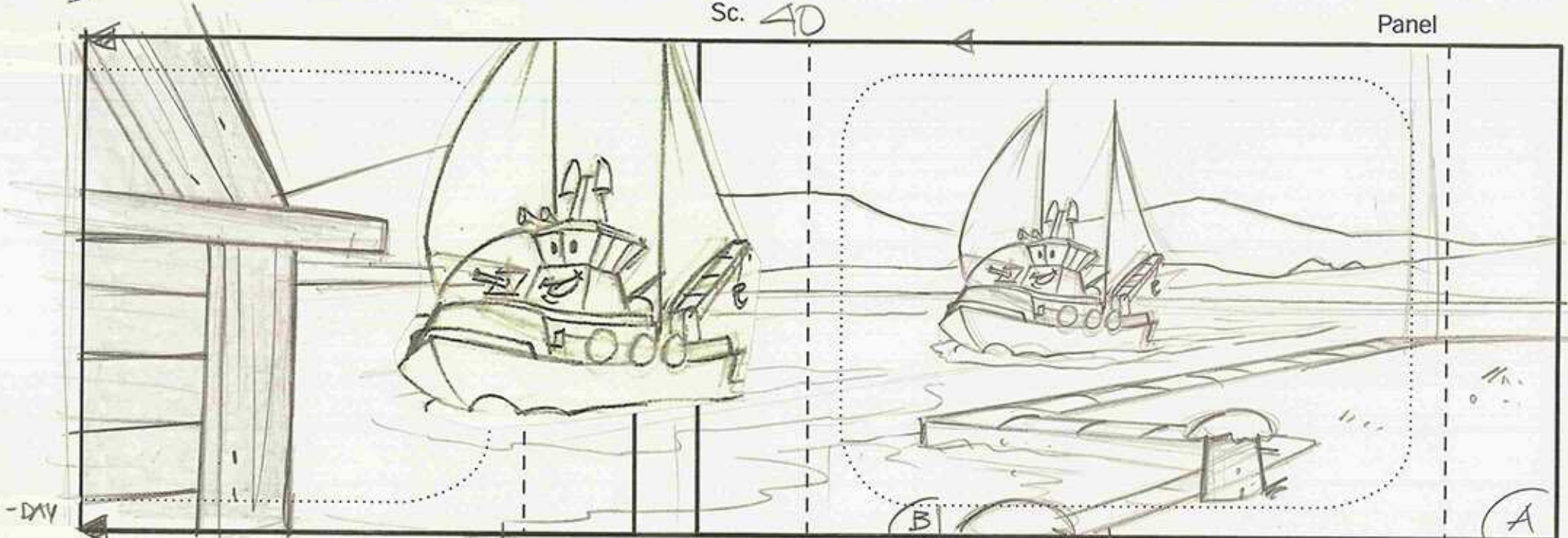

EXT. BOATHOUSE - DAY

Dialogue Action

ANGLE ON TUG SAILING UP TOWARDS THE BOATHOUSE. EFX: (S/T WATER.)

Dialogue Action

PAN PAN W/ANIM. (A) → (B)

(31) TUG: (CONTD).

RAN OUT OF GAS YESTERDAY AND PUT THESE UP...

HU CUT

257-786





# FIREHOUSE TALES

©2005 Warner Bros. This Material is the PROPERTY OF WARNER BROS. TELEVISION ANIMATION. It is unpublished and must not be taken from the studio, duplicated or used in any manner, except for production purposes, and may not be sold or transferred.

Sc. 41

Panel

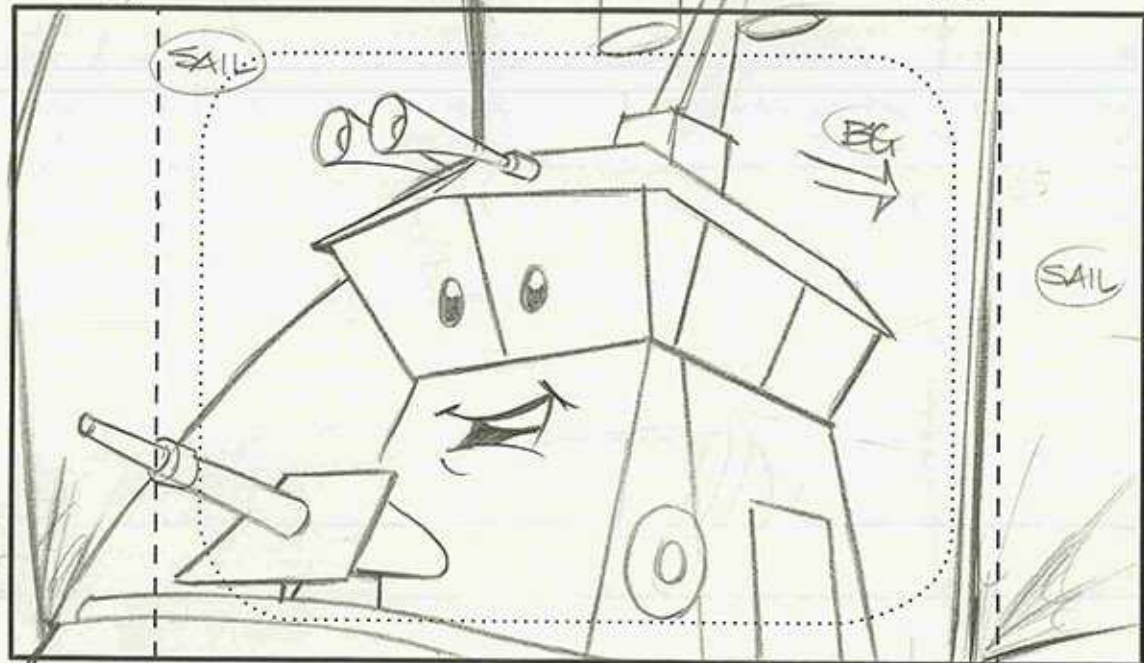

HU

CUT

Dialogue Action

CLOSE ON TUG  
PAN BG

EFX: (SPL WATER)

(S) TUG: (CONTD)

NICE, AREN'T THEY?

CUT

Sc. 42

S/A

Panel (A)

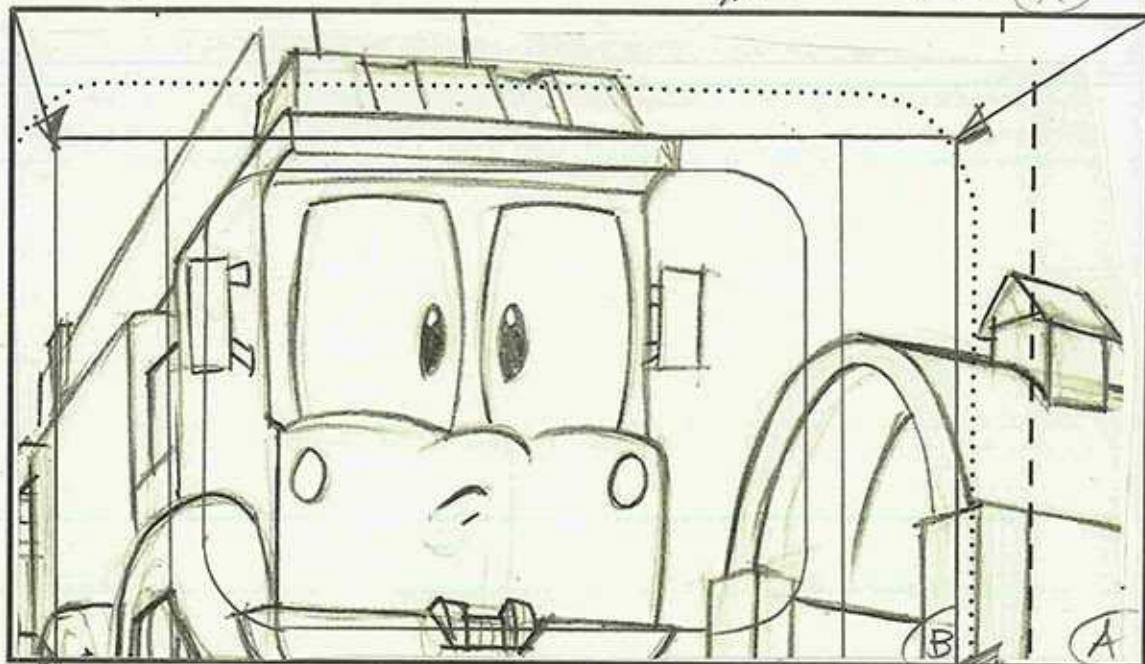

Dialogue Action

CLOSE ON RED, LOOKING AT OS TUG, THINKING  
TRUCK IN (A) → (B).

257-786





# FIREHOUSE TALES

©2005 Warner Bros. This Material is the PROPERTY OF WARNER BROS. TELEVISION ANIMATION. It is unpublished and must not be taken from the studio, duplicated or used in any manner, except for production purposes, and may not be sold or transferred.

Sc. 42 CONTD.

Panel (B)

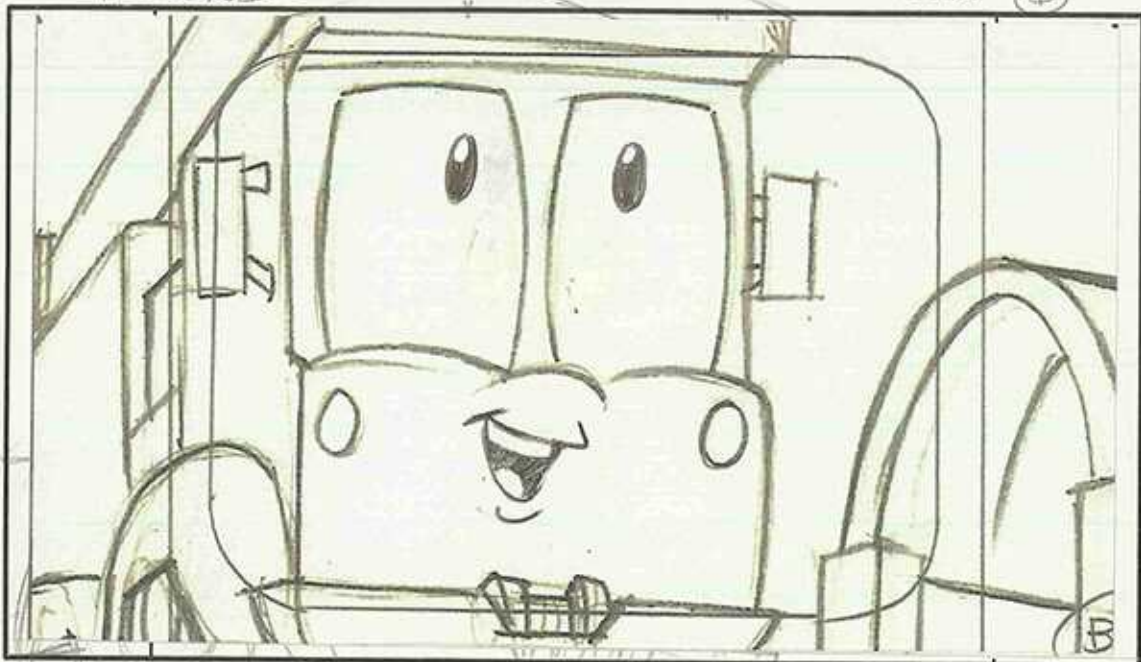

Dialogue Action

RED BRIGHTENS. HE'S GOT AN IDEA.

(31A) RED: (INSPIRED)  
HEY!

X-DISS

Sc.

Panel (A)

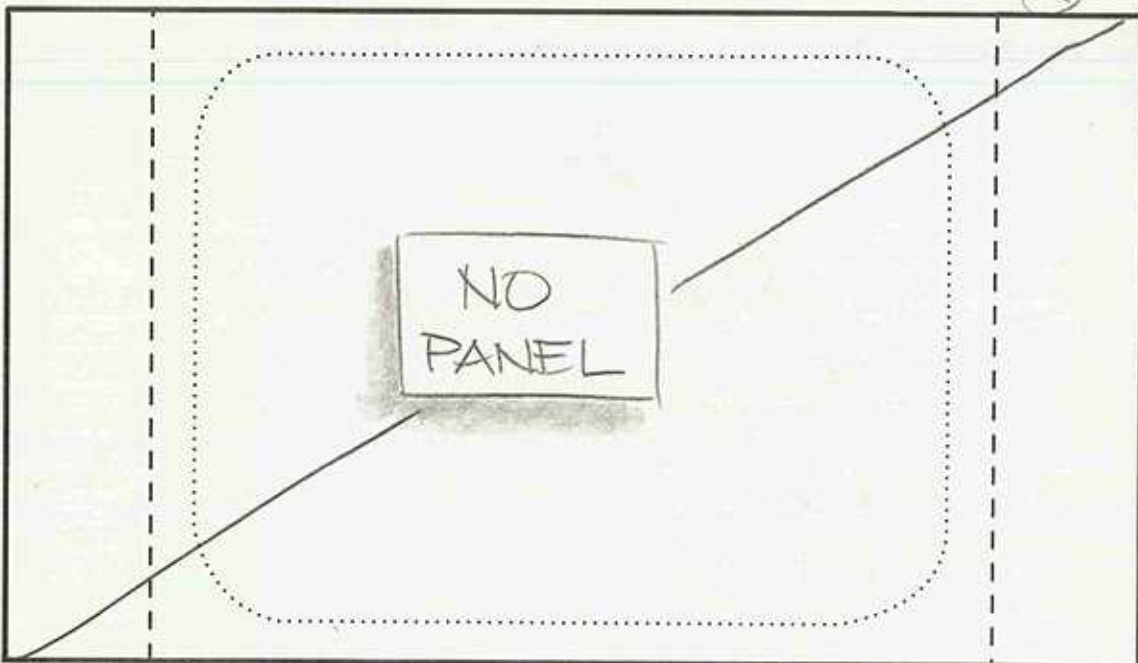

Dialogue Action





# FIREHOUSE TALES

©2005 Warner Bros. This Material is the PROPERTY OF WARNER BROS. TELEVISION ANIMATION. It is unpublished and must not be taken from the studio, duplicated or used in any manner, except for production purposes, and may not be sold or transferred.

Sc. 43

Panel

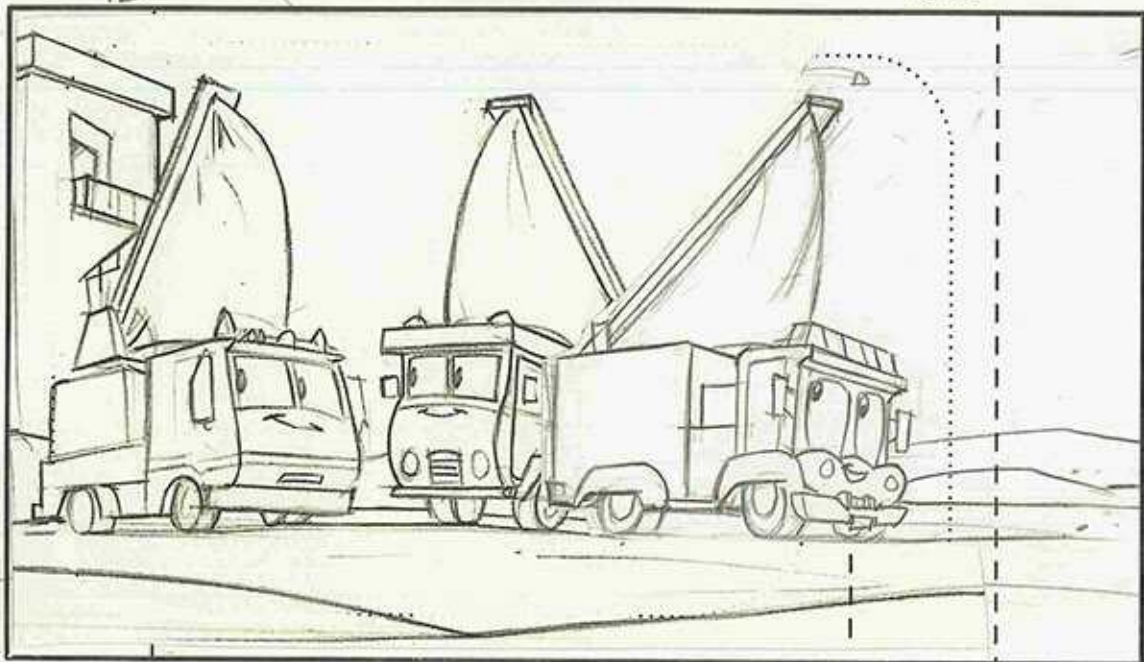

Sc. 44

Panel A

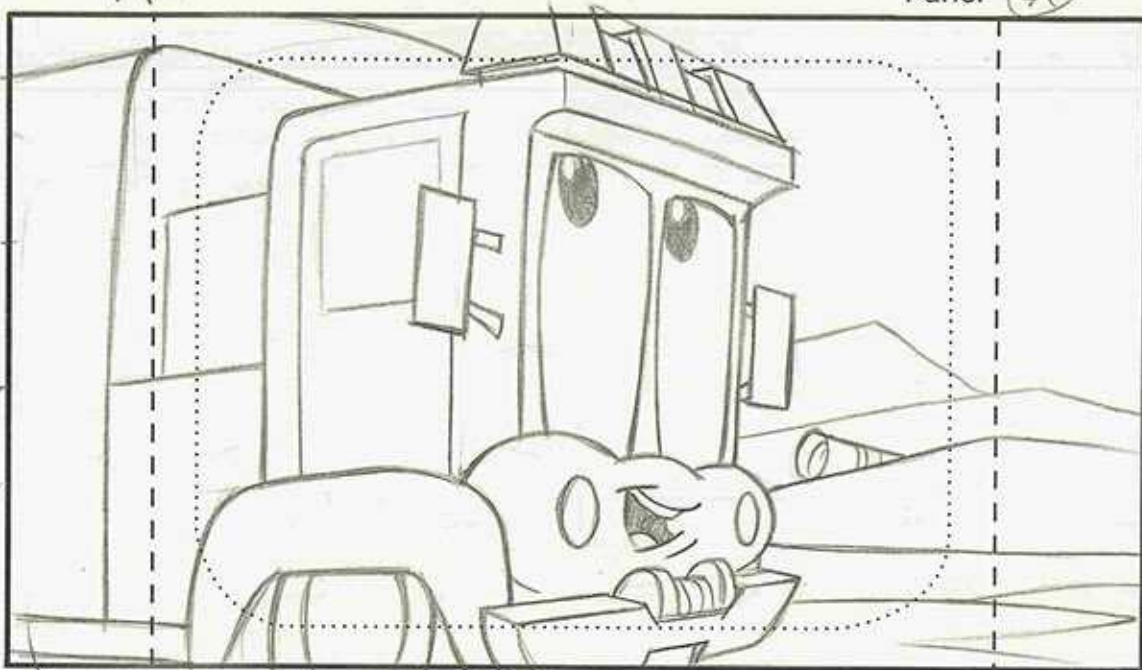

CUT

**Action** EXT. PRACTICE AREA - LATER  
WIDE ON THE TRUCKS. TECH HAS ATTACHED SHEETS TO THE BOY'S LADDERS.

HU

CUT

**Dialogue**

32 RED:  
THIS IS GREAT!

CLOSE ON RED

32 RED: (CONTD).  
NOW ALL WE HAVE TO DO...





# FIREHOUSE TALES

©2005 Warner Bros. This Material is the PROPERTY OF WARNER BROS. TELEVISION ANIMATION. It is unpublished and must not be taken from the studio, duplicated or used in any manner, except for production purposes, and may not be sold or transferred.

Sc. 4A CONTD

Panel (B)

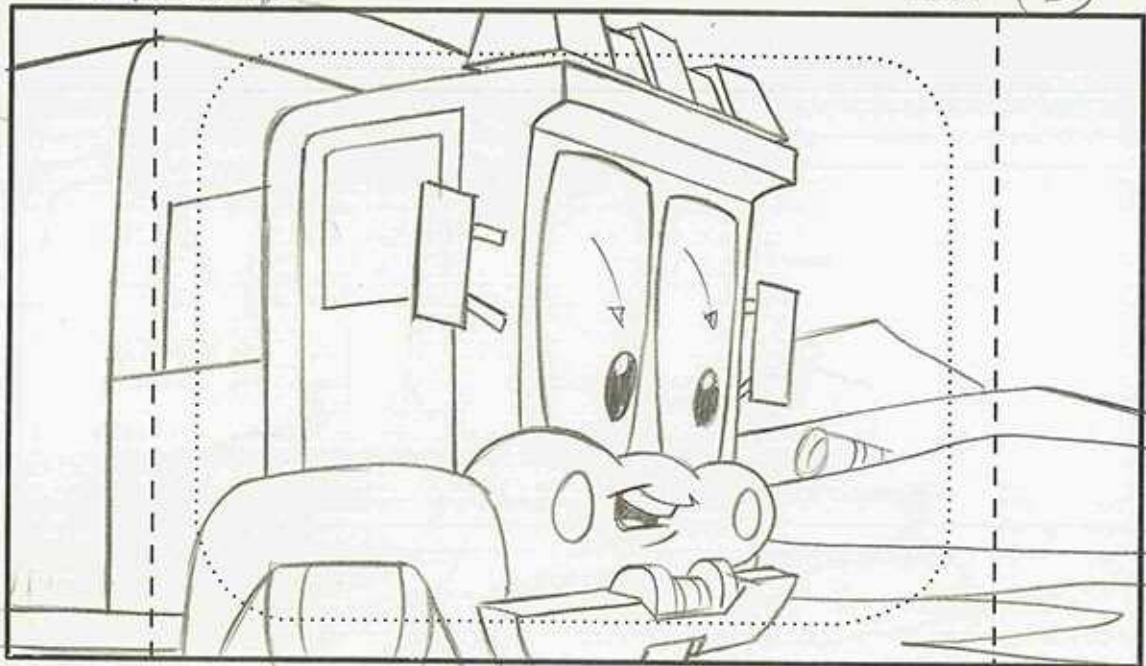

Dialogue Action

RED LOOKS OVER AT O.S. TECH.

(32) RED: (CONTD)

... IS WAIT FOR SOME ...

Sc. CONTD

Panel

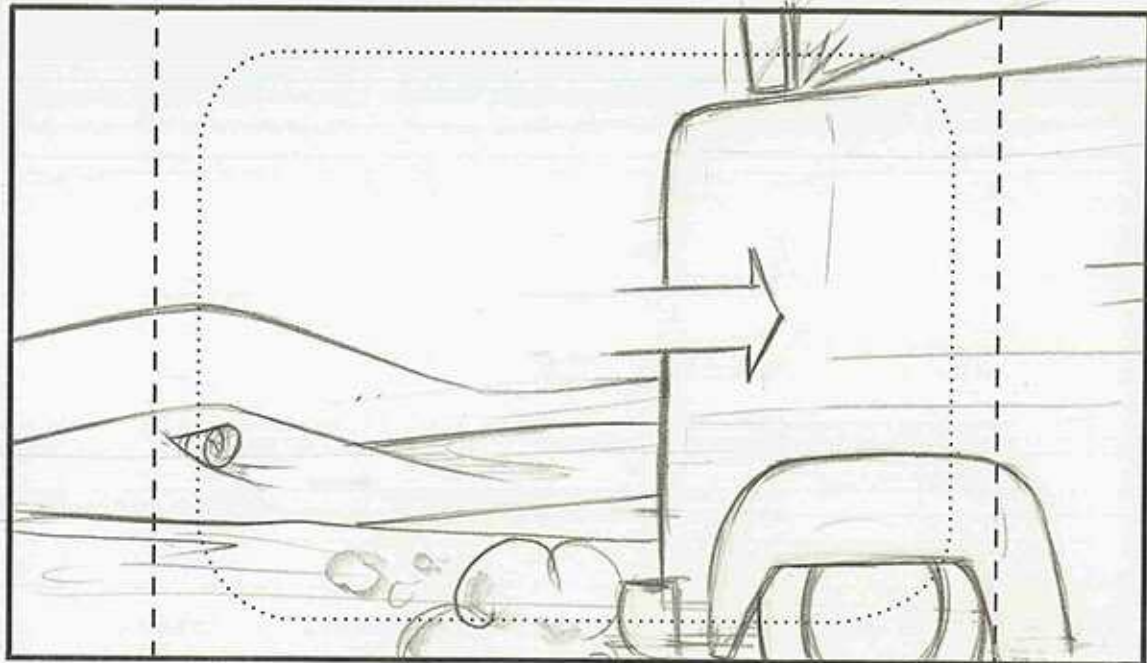

Dialogue Action

RED IS BLOWN FORWARD BY A GUST OF WIND.

EFX: (DX DUST)

(32) RED: (CONTD)

... WIIINNND...





# FIREHOUSE TALES

©2005 Warner Bros. This Material is the PROPERTY OF WARNER BROS. TELEVISION ANIMATION. It is unpublished and must not be taken from the studio, duplicated or used in any manner, except for production purposes, and may not be sold or transferred.

Sc. 44 CONTD.

Panel (D)

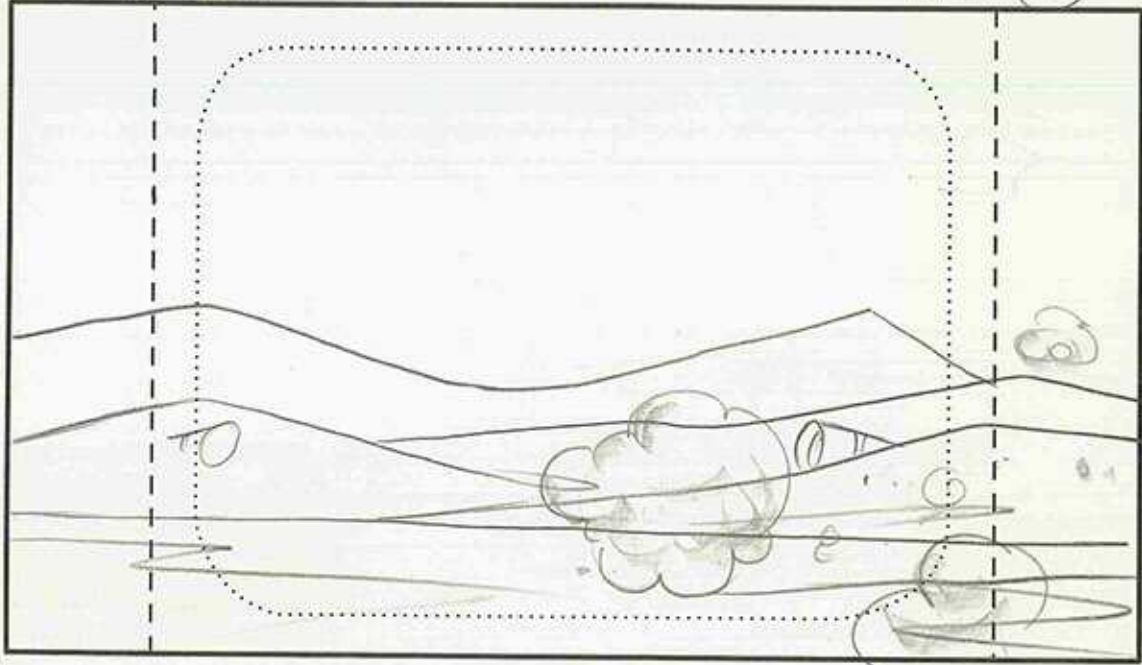

Dialogue Action

RED OUT, DUST DISSIPATES.

EFF: (DX DUST).

CUT

Sc. 45

SA. 43 Panel (A)

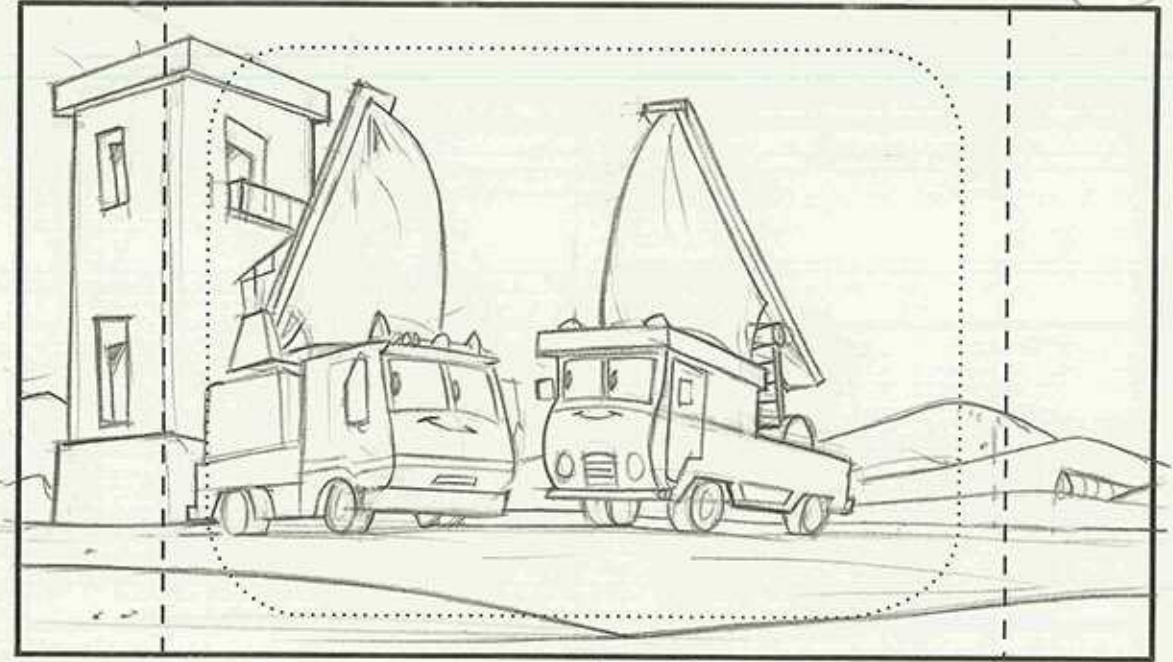

Dialogue Action

WIDE ON CRABBY & PETROL





# FIREHOUSE TALES

©2005 Warner Bros. This Material is the PROPERTY OF WARNER BROS. TELEVISION ANIMATION. It is unpublished and must not be taken from the studio, duplicated or used in any manner, except for production purposes, and may not be sold or transferred.

Sc. 45 CONTD.

Panel

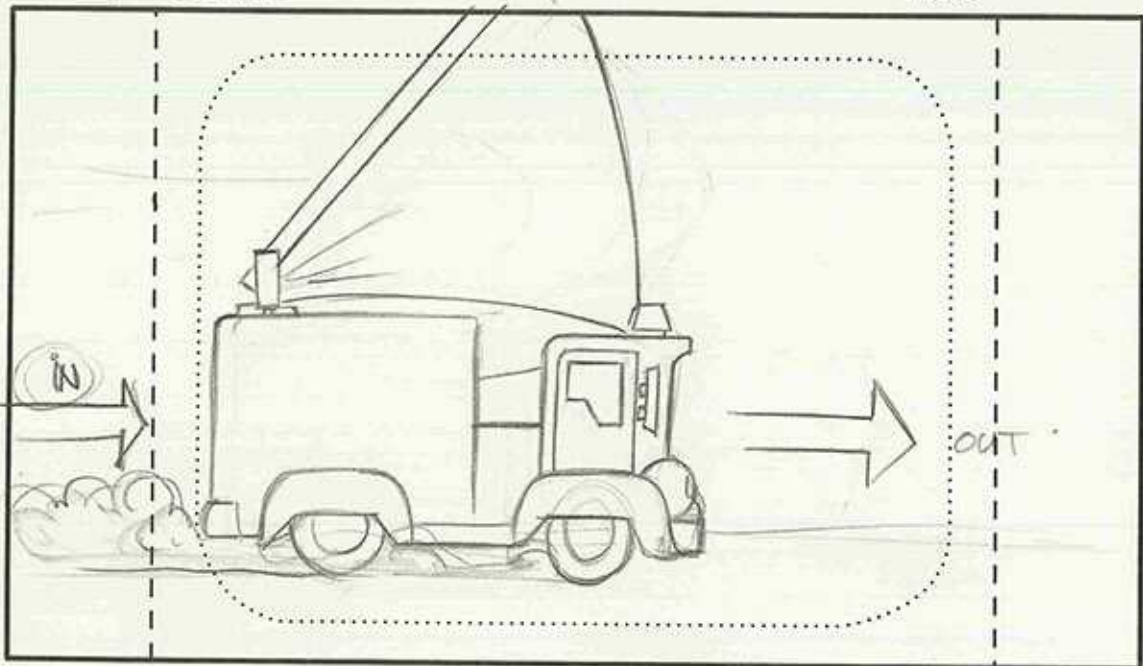

**Dialogue Action** RED SAILS THROUGH SCENE.

EFX: (DX DUST)

(33) RED: (LAUGHING)

COME ON GUYS ..

Sc. 46

Panel (A)

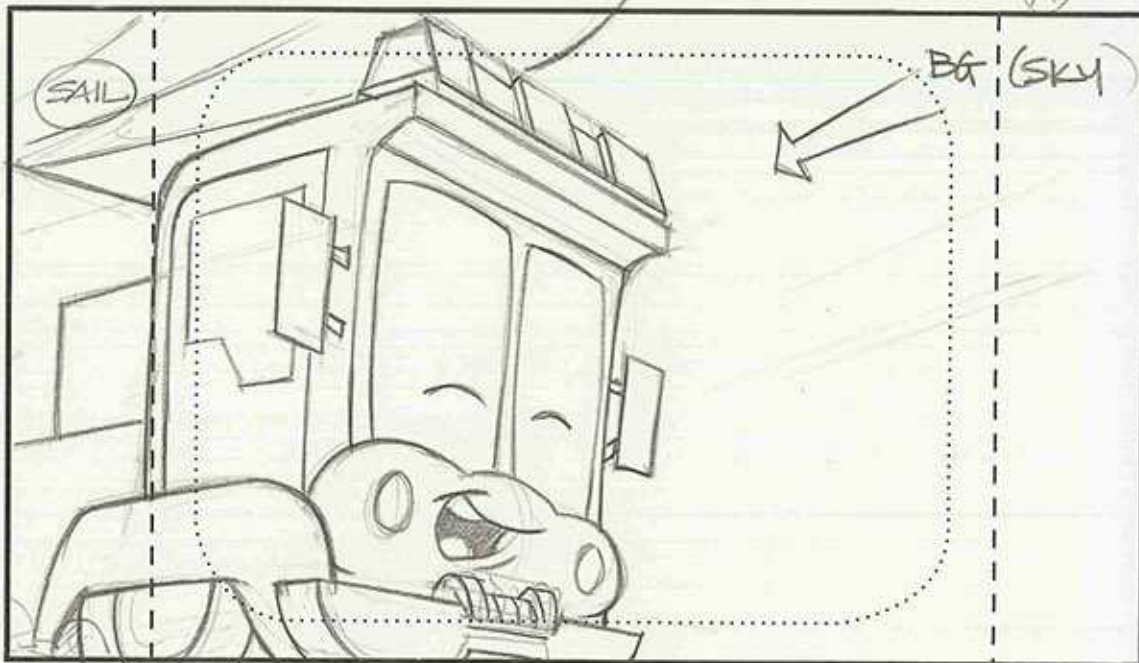

**Dialogue Action** CLOSE ON AN EXCITED RED.

(PAN BG)

(33) RED: (CONTD)

.. LEAN ..





# FIREHOUSE TALES

©2005 Warner Bros. This Material is the PROPERTY OF WARNER BROS. TELEVISION ANIMATION. It is unpublished and must not be taken from the studio, duplicated or used in any manner, except for production purposes, and may not be sold or transferred.

Page

Sc. 48

Panel

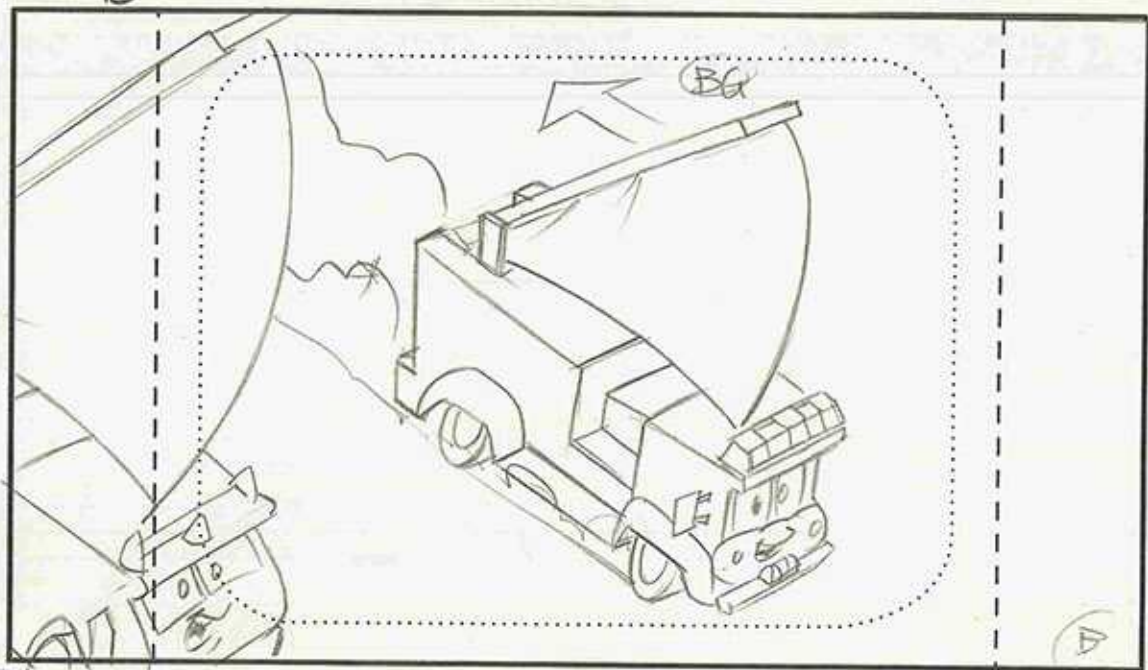

**Dialogue Action**  
DOWN ANGLE ON PRACTICE YARD. RED IS RACING ALONG. TRUCK OUT (A) → (B). CRABBY GAINS IN. EFX: (DX DUST)

**Dialogue** (34) PETROL / CRABBY

(WHEEEE ~~~~~ !)

Sc. CONTD.

Panel

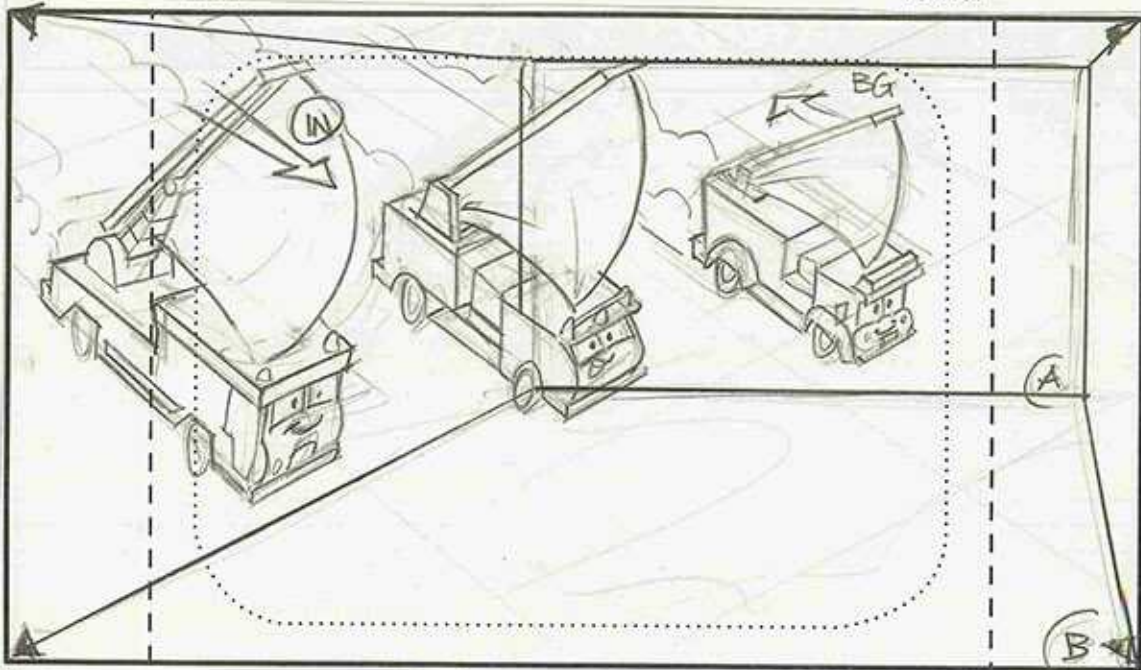

**Dialogue Action**  
FOLLOWED BY PETROL

CUT





# FIREHOUSE TALES

©2005 Warner Bros. This Material is the PROPERTY OF WARNER BROS. TELEVISION ANIMATION. It is unpublished and must not be taken from the studio, duplicated or used in any manner, except for production purposes, and may not be sold or transferred.

Sc. 49

Panel

Sc.

Panel

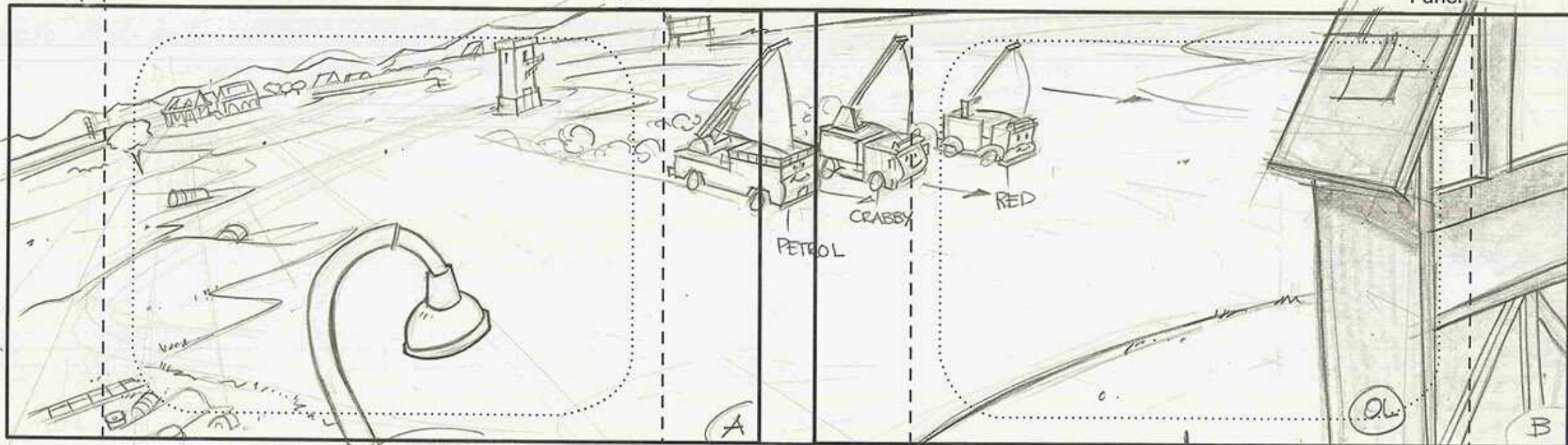

CUT

Dialogue Action

EXT PRACTICE YARD. (START)

PAN PAST THE RACING TRUCKS.

PAN (A) → (B) EFX: (DX DUST)

Dialogue Action

PAN → (STOP)





# FIREHOUSE TALES

©2005 Warner Bros. This Material is the PROPERTY OF WARNER BROS. TELEVISION ANIMATION. It is unpublished and must not be taken from the studio, duplicated or used in any manner, except for production purposes, and may not be sold or transferred.

Sc. 49 CONTD -

Panel B

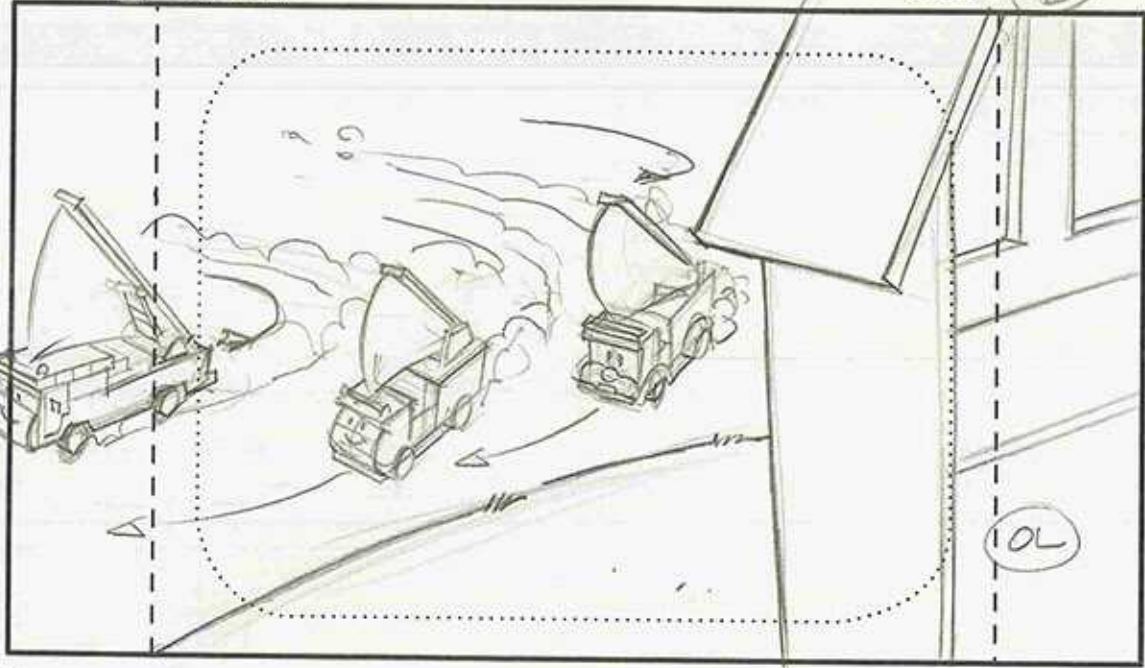

**Dialogue Action** THE TRUCKS CHANGE TACK AND TURN AROUND.

EFX: (DX DUST)

CUT

Sc. 50

Panel

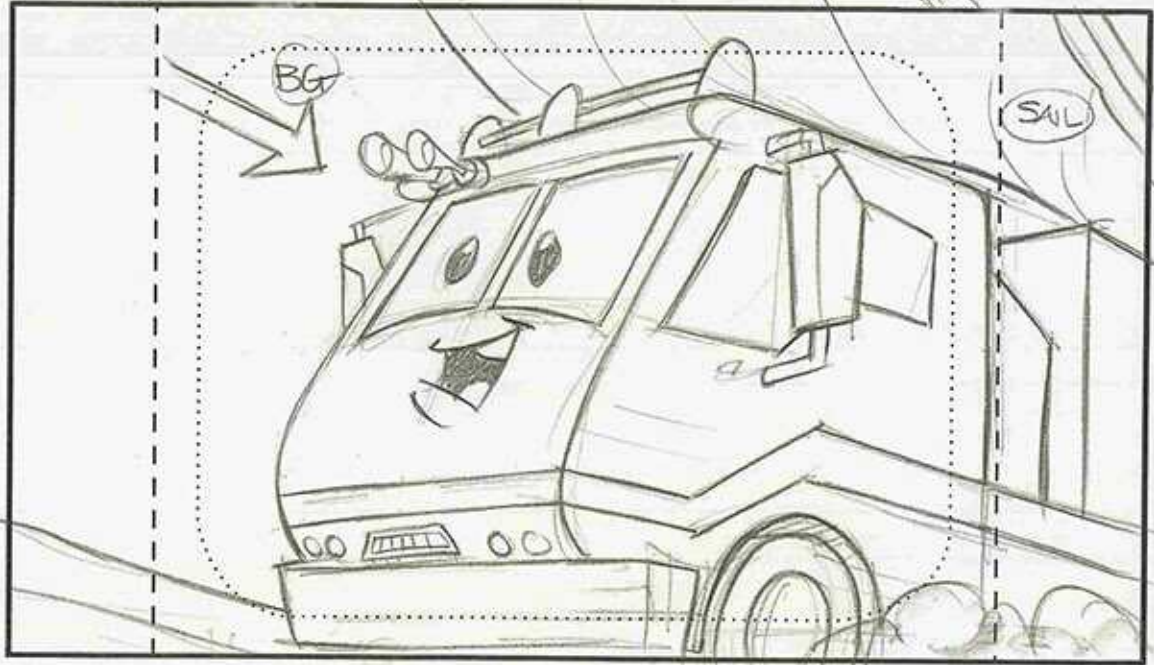

**Dialogue Action** CLOSE ON AN EXCITED CRABBY.

(PAN BG)

EFX: (DX DUST)

CUT

35 CRABBY:

I FEEL JUST LIKE A SHIP.

257-786





# FIREHOUSE TALES

©2005 Warner Bros. This Material is the PROPERTY OF WARNER BROS. TELEVISION ANIMATION. It is unpublished and must not be taken from the studio, duplicated or used in any manner, except for production purposes, and may not be sold or transferred.

Sc. 51

Panel A

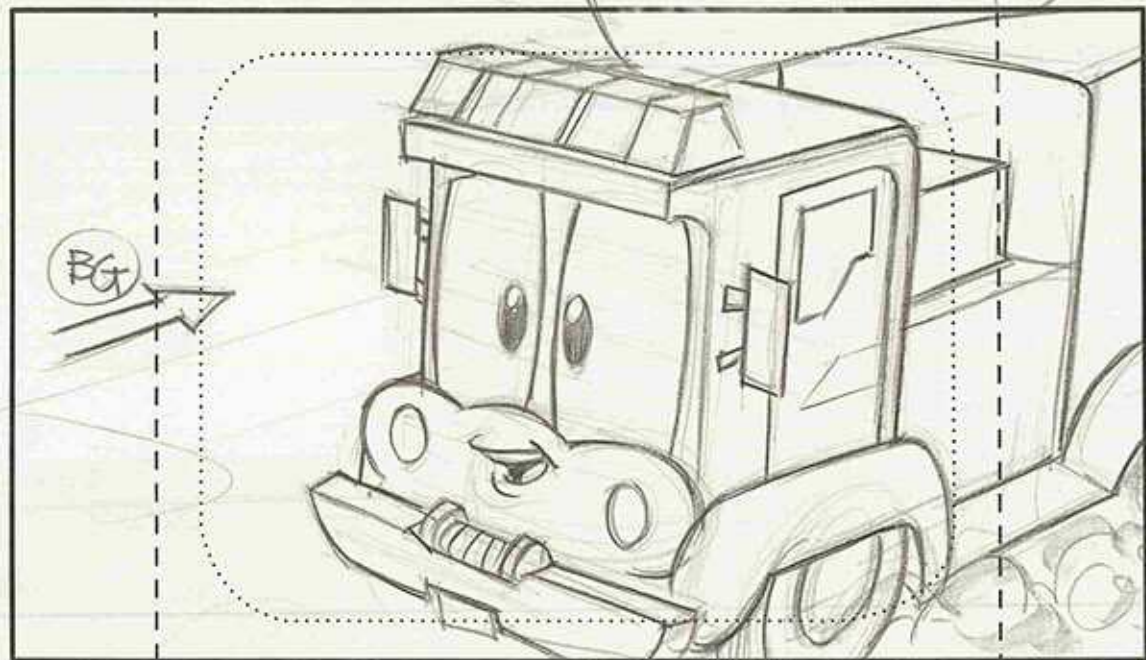

Action ANGLE ON RED

EFX: (DX DUST)

Dialogue (36) RED:

YEAH...

Sc. CONTD

Panel B

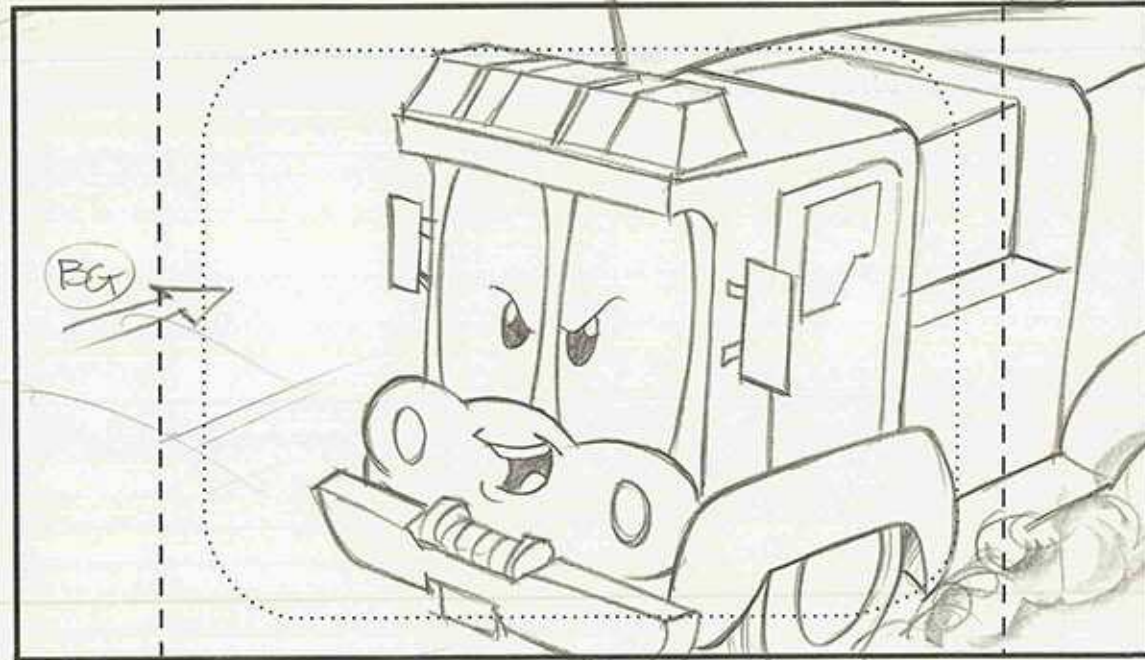

Action

Dialogue (36) RED: (CONTD)

.. A PIRATE SHIP!





# FIREHOUSE TALES

©2005 Warner Bros. This Material is the PROPERTY OF WARNER BROS. TELEVISION ANIMATION. It is unpublished and must not be taken from the studio, duplicated or used in any manner, except for production purposes, and may not be sold or transferred.

Sc. 51 CONTD

Panel (C)

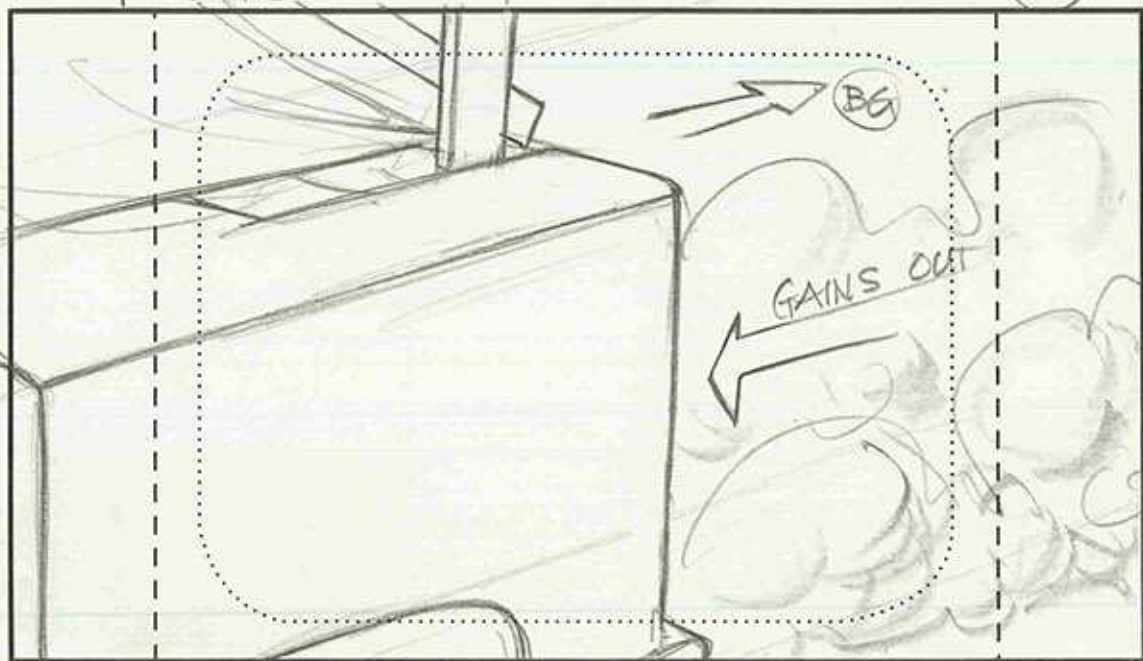

Dialogue Action

RED GAINS OUT

EFX: (DX DUST)

Sc. 52

Panel SAIL

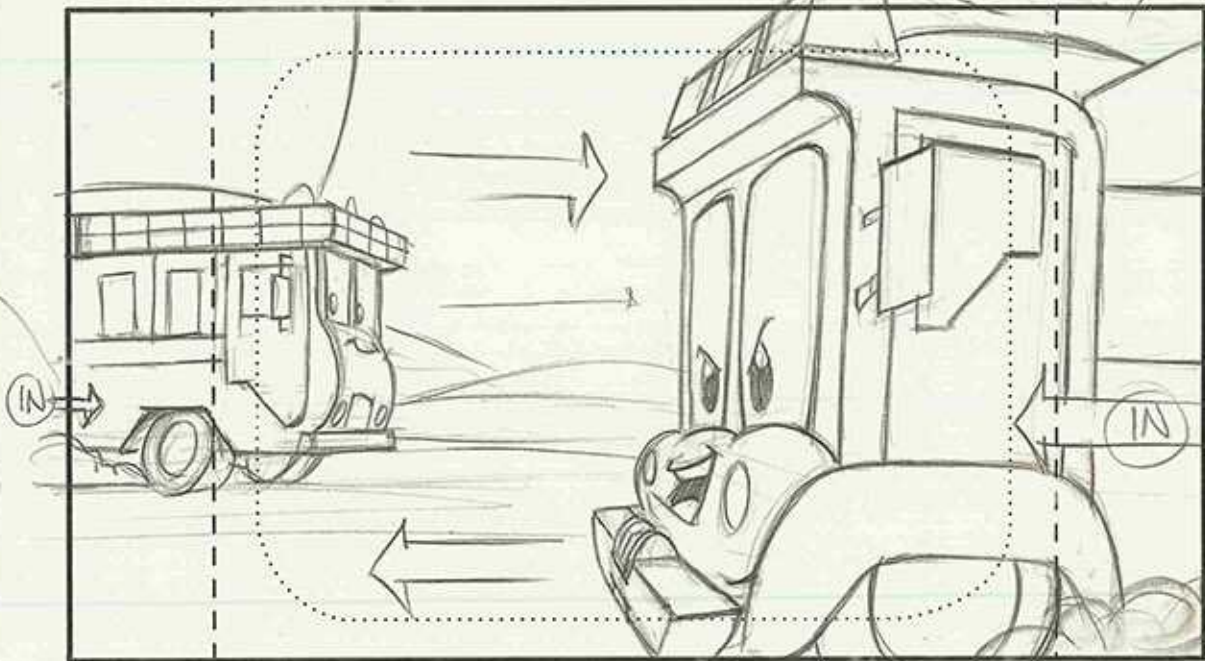

Dialogue Action

ANGLE ON PRACTISE YARD. PETROL RACES IN (FROM LEFT) AND THROUGH SCENE. RED RACES IN FROM RIGHT. EFX: (DX DUST)

CUT

CUT

(37) RED: (PIRATE VOICE)

AHE, I LOVE TO SAIL ACROSS THE SEA,





# FIREHOUSE TALES

©2005 Warner Bros. This Material is the PROPERTY OF WARNER BROS. TELEVISION ANIMATION. It is unpublished and must not be taken from the studio, duplicated or used in any manner, except for production purposes, and may not be sold or transferred.

Sc. 53

Panel (A)

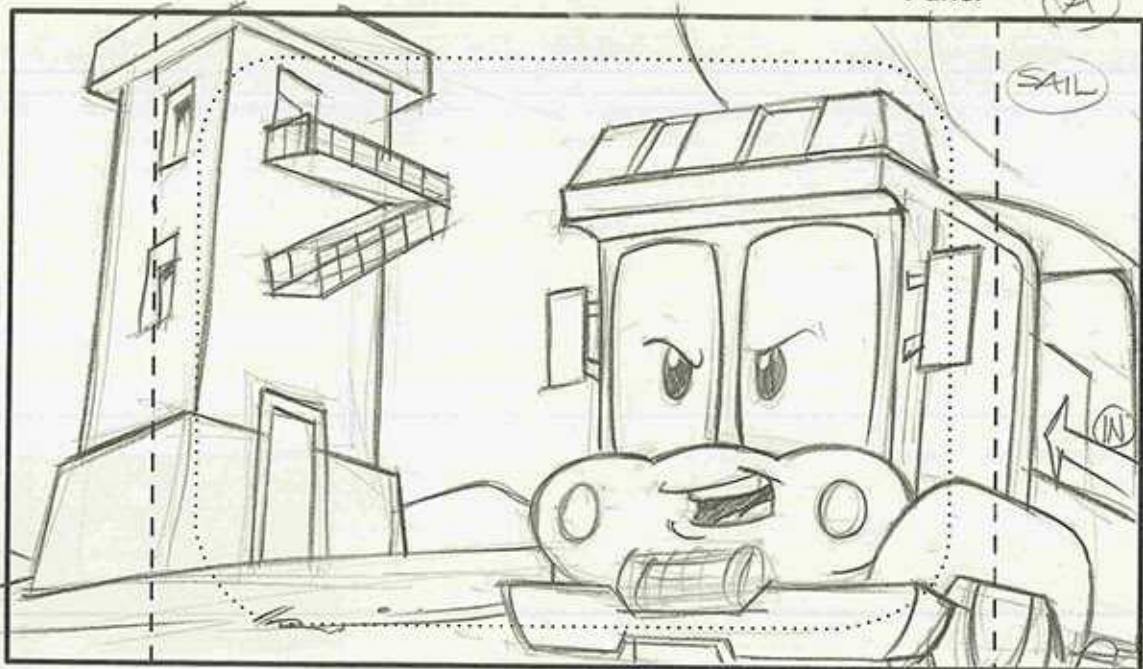

**Action** ANGLE ON FRACTISE BUILDING - RED SAILS. PAST.

(CUT)

**Dialogue** (37) RED: (CONTD).

.. 'CAUSE I'M THE BEST PIRATE SHIP ..

Sc.

CONTD

Panel (B)

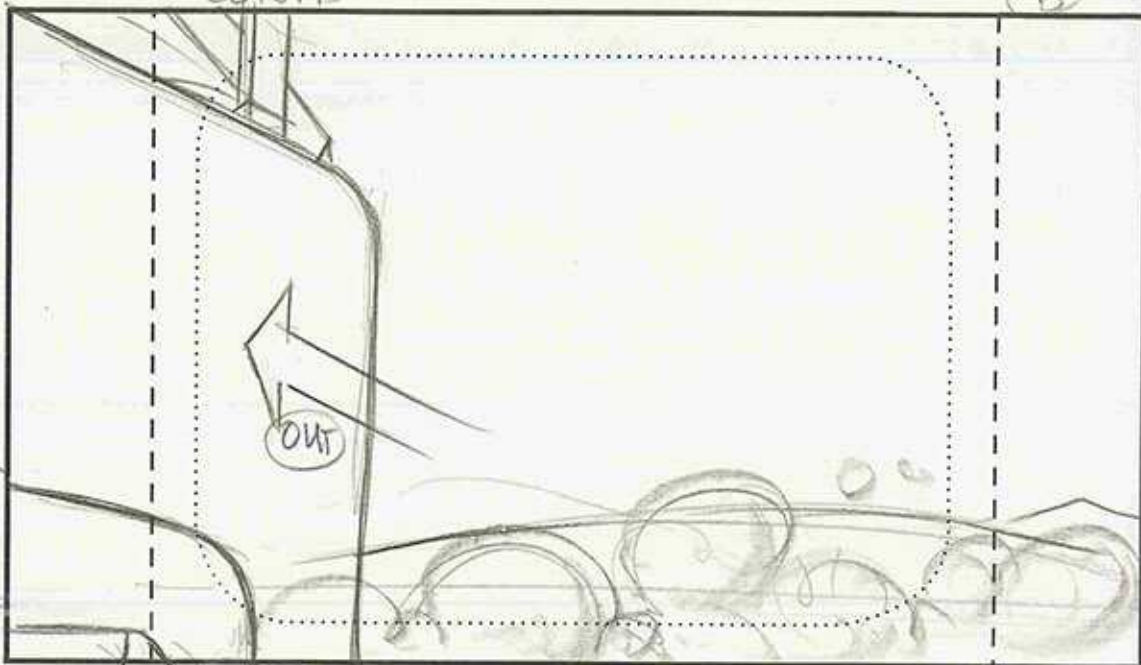

**Action** (CUT ON ACTION).

(CUT)

**Dialogue** (37) RED: (CONTD)

.. THERE BE .





# FIREHOUSE TALES

©2005 Warner Bros. This Material is the PROPERTY OF WARNER BROS. TELEVISION ANIMATION. It is unpublished and must not be taken from the studio, duplicated or used in any manner, except for production purposes, and may not be sold or transferred.

Sc. 5A

Panel (A)

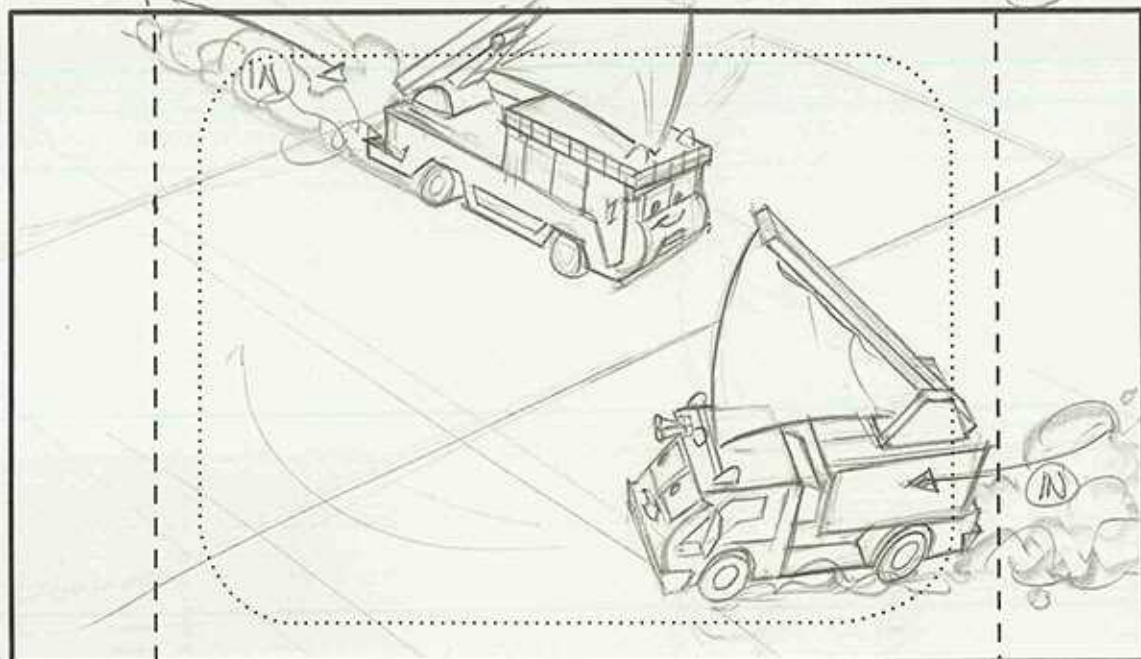

CUT

Dialogue Action

DOWN SHOT ON PRACTISE AREA.  
CRABBY & PETROL CIRCLE EACH OTHER.

EFX: (DX DUST).

(38) CRABBY:

ARRRGH, YOU SCALLYWAGS,

Sc. CONTD

Panel (B)

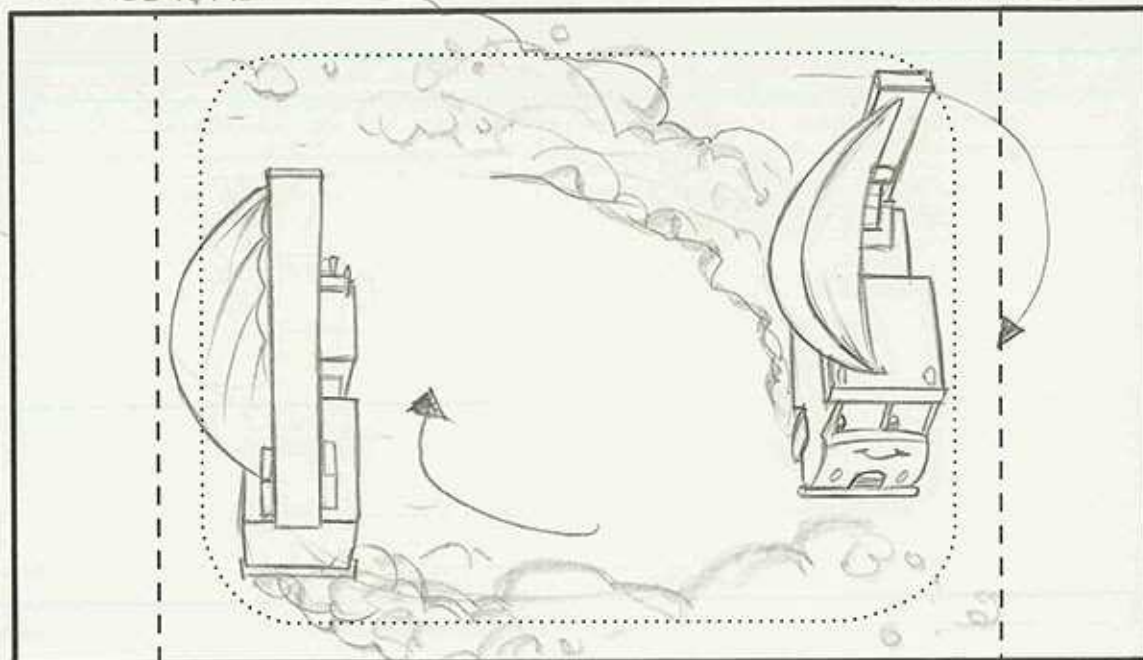

Dialogue Action

(38) CRABBY: (CONTD).

.. SURRENDER YOUR BOUNTY OR ELSE!

CUT





# FIREHOUSE TALES

©2005 Warner Bros. This Material is the PROPERTY OF WARNER BROS. TELEVISION ANIMATION. It is unpublished and must not be taken from the studio, duplicated or used in any manner, except for production purposes, and may not be sold or transferred.

Sc. 55

Panel

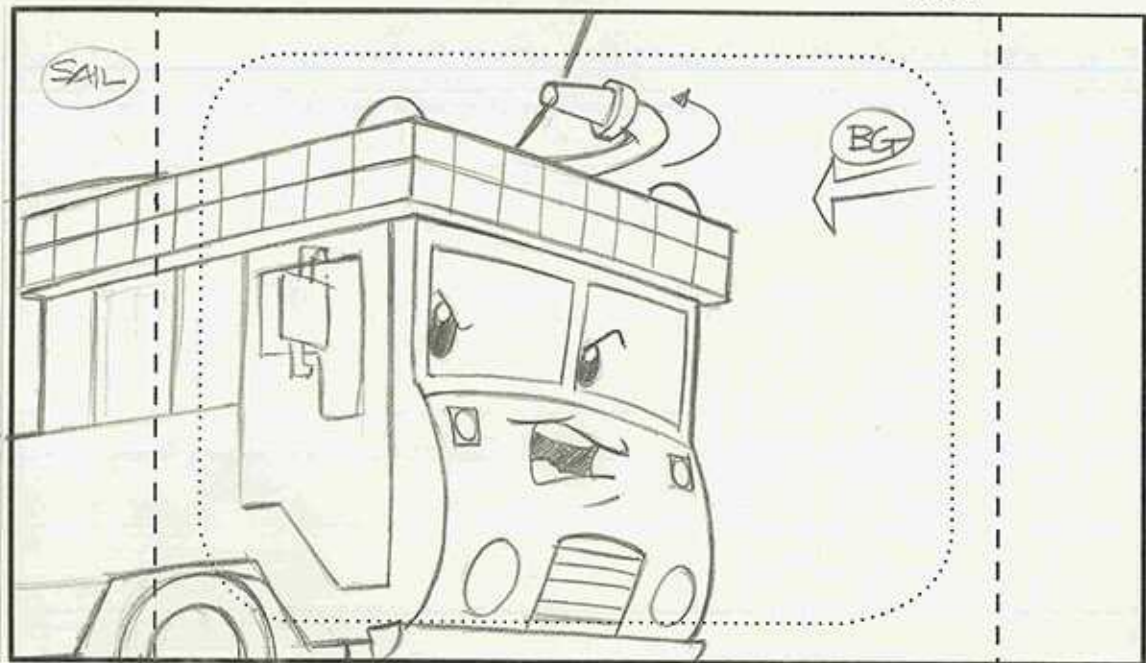

**CUT** Action CLOSE ON PETROL. HE AIMS HIS FIRE HOSE.  
(PAN BG)

**Dialogue** (39) PETROL:  
NO WAY, CAP'N CRABBY. I'LL NEVER  
GIVE UP. I'M LOADIN' ME CANNONS.

Sc. 56

Panel

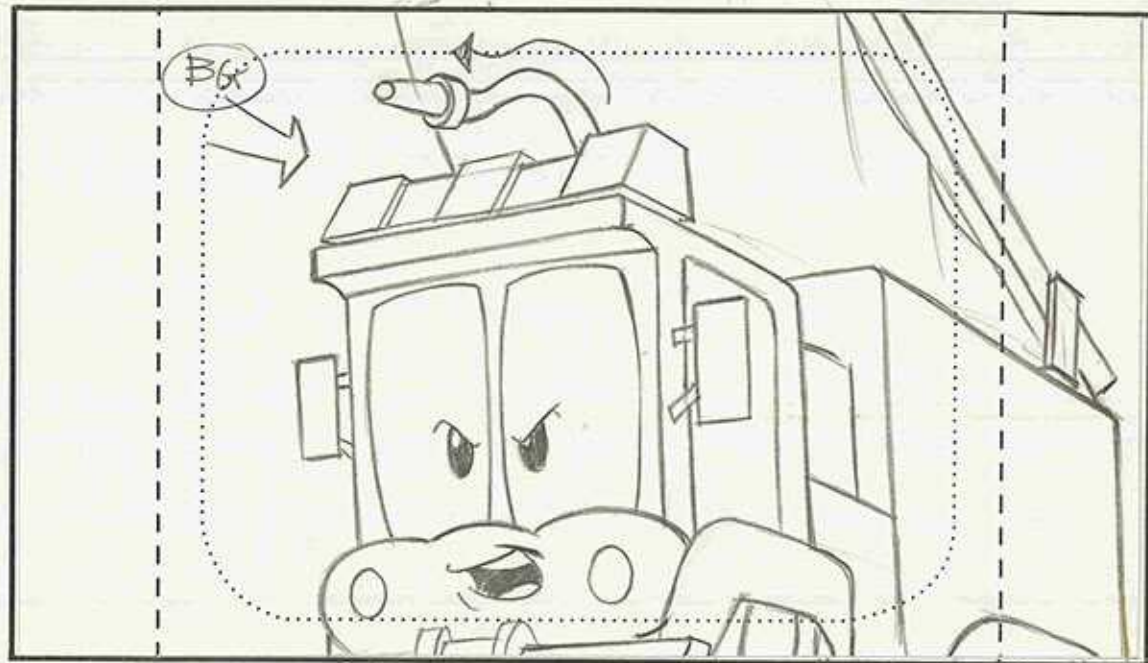

**CUT** Action CLOSE ON RED.  
(PAN BG)

**Dialogue** (40) RED: (PIRATE VOICE).  
YO HO HO. ME CANNONS ARE  
ALREADY LOADED!





# FIREHOUSE TALES

©2005 Warner Bros. This Material is the PROPERTY OF WARNER BROS. TELEVISION ANIMATION. It is unpublished and must not be taken from the studio, duplicated or used in any manner, except for production purposes, and may not be sold or transferred.

Sc. 57

Panel (A)

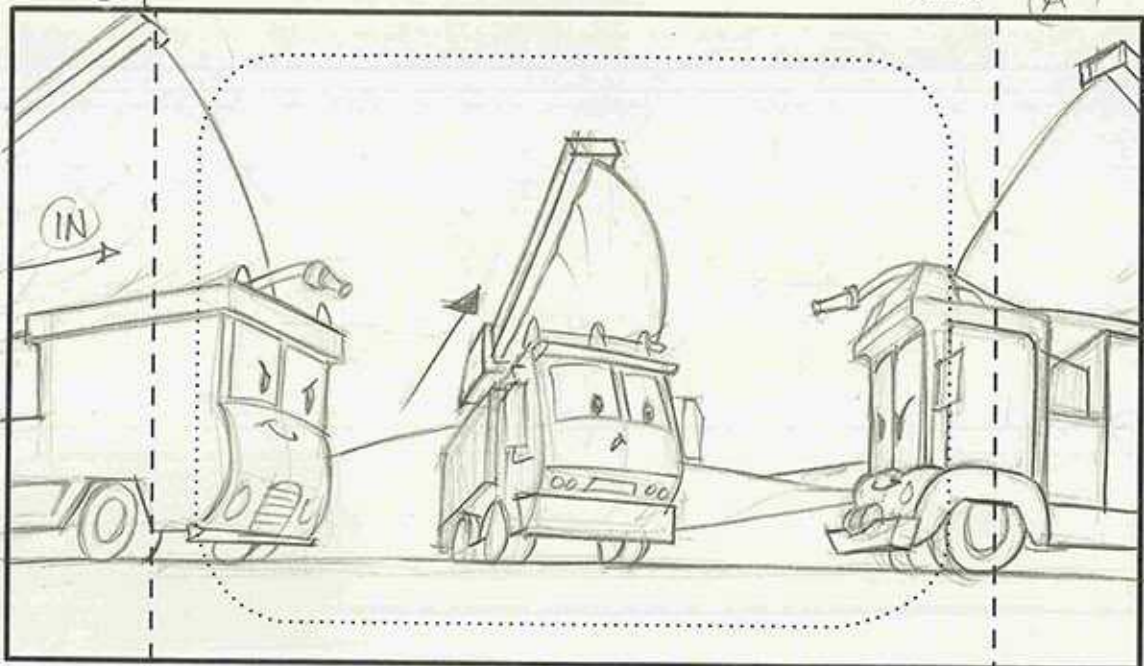

**CUT**  
**Dialogue Action** ANOTHER ANGLE ON PRACTISE AREA.  
CRABBY ROLLS FORWARD RED IS LAYING IN WAIT AS  
PETROL SLIDES IN. THEY'VE BOXED CRABBY IN.

Sc. CONTD

Panel (B)

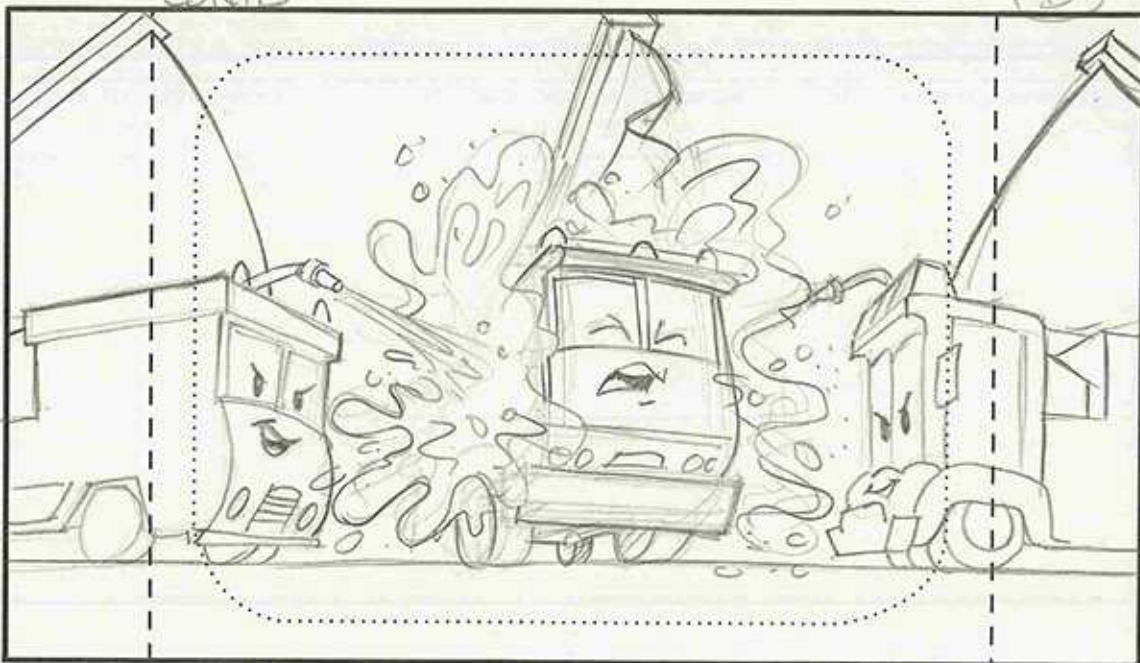

**Dialogue Action** PETROL & RED HOSE CRABBY DOWN.

EFX: (S/T WATER SPRAY)  
(4) CRABBY: (THRILLED)  
BLIMEY!

**CUT**

257-786





# FIREHOUSE TALES

©2005 Warner Bros. This Material is the PROPERTY OF WARNER BROS. TELEVISION ANIMATION. It is unpublished and must not be taken from the studio, duplicated or used in any manner, except for production purposes, and may not be sold or transferred.

Sc. 58

Panel A

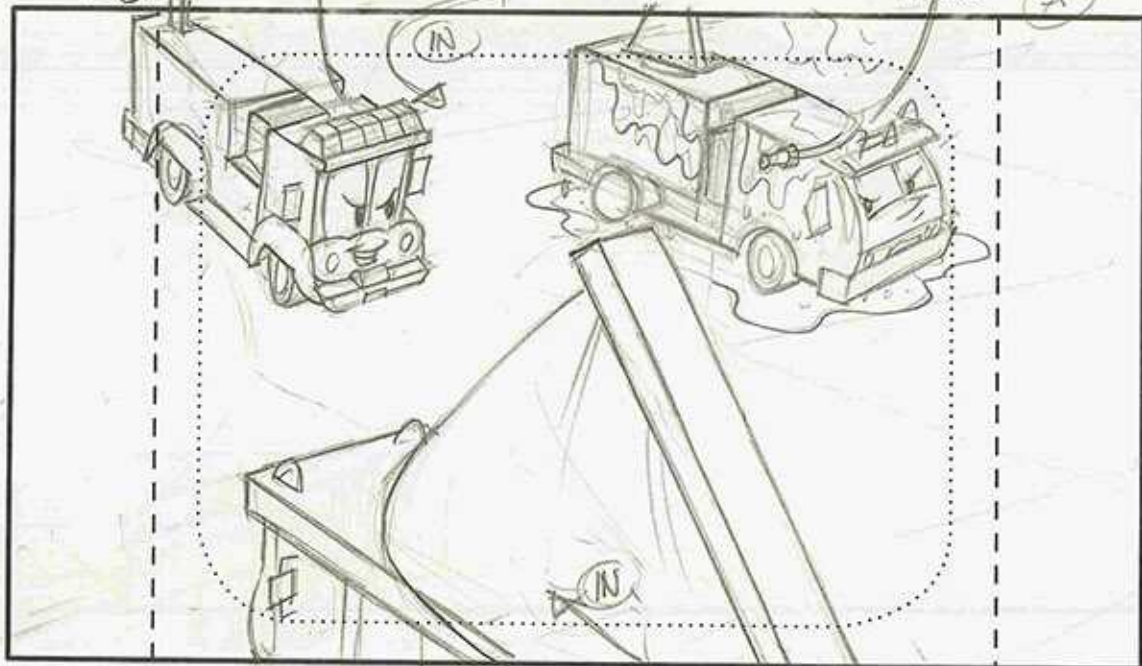

Dialogue Action

WIDER ON THE TRUCKS CRABBY'S STOPPED, HE'S DRIPPING HE AIMS HIS HOSE AT RED, WHO SWINGS AROUND CRAPPY. PETREL ENTERS IN.  
EFX: (S/T WATER DRIPS)

Sc. CONTD

Panel B

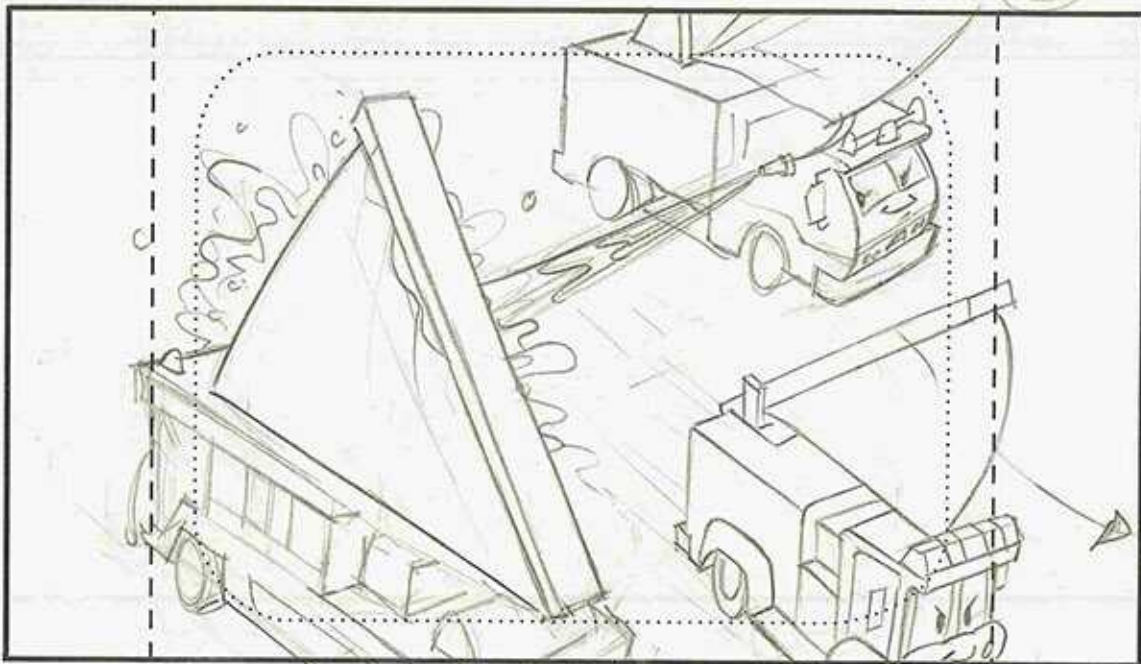

Dialogue Action

RED ZIPS PAST CRABBY, WHO FIRES HIS HOSE. THE WATER SPRAY MISSES RED BUT HITS PETREL.  
EFX: (S/T WATER SPRAY)

257-786





# FIREHOUSE TALES

©2005 Warner Bros. This Material is the PROPERTY OF WARNER BROS. TELEVISION ANIMATION. It is unpublished and must not be taken from the studio, duplicated or used in any manner, except for production purposes, and may not be sold or transferred.

Sc. 59

Panel (A)

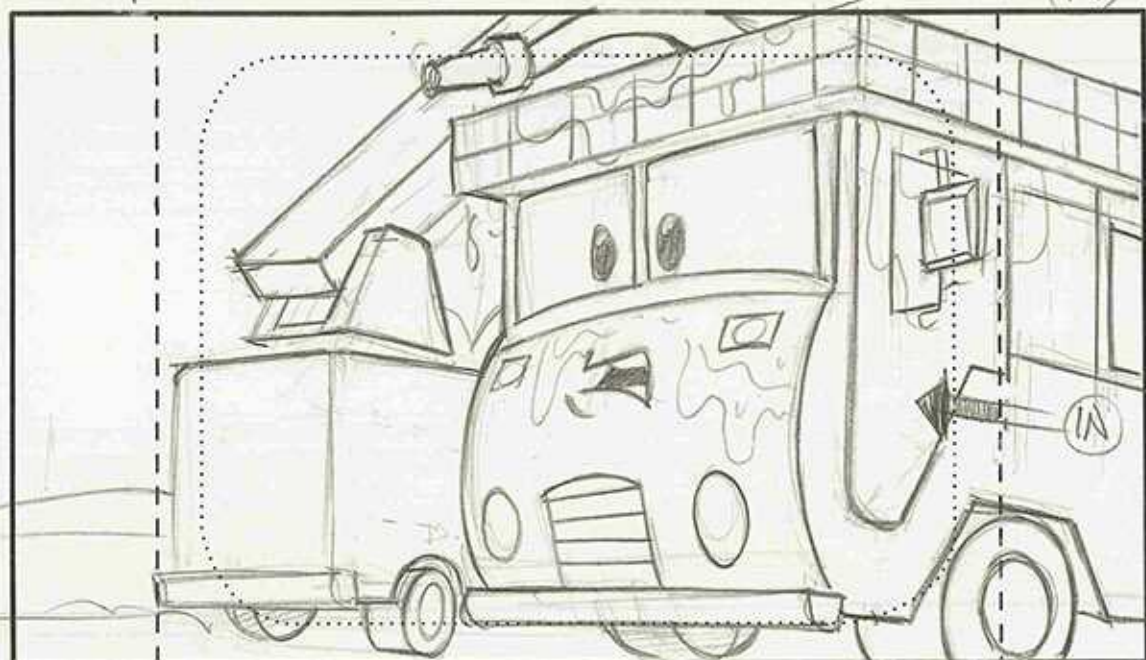

**CUT**  
**Action** CLOSER ON PETROL AS HE DRIVES PAST CRABBY WHO TAKES OFF IN THE OPPOSITE DIRECTION  
EFF: < S/T DRIPS

**Dialogue** (42) PETROL:  
WELL, SHNER ME TIMBERS!

Sc. CONTD

Panel (B)

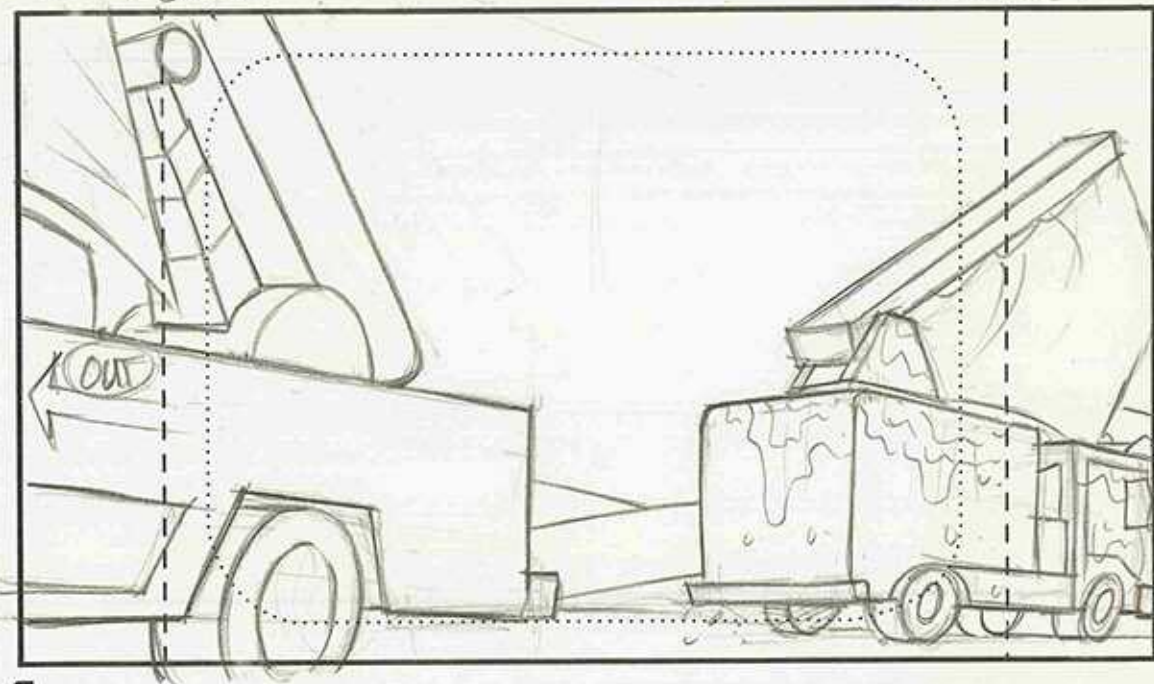

**Dialogue**

**CUT**

257-786





# FIREHOUSE TALES

©2005 Warner Bros. This Material is the PROPERTY OF WARNER BROS. TELEVISION ANIMATION. It is unpublished and must not be taken from the studio, duplicated or used in any manner, except for production purposes, and may not be sold or transferred.

Sc. 60

SA 42 Panel

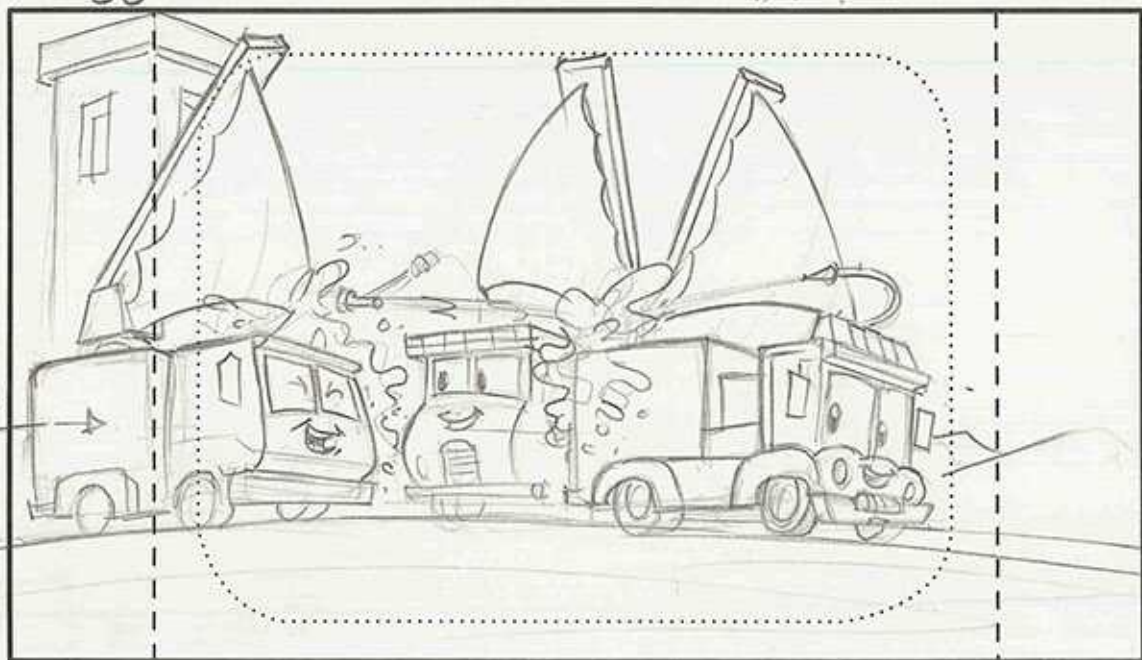

Sc.

Panel

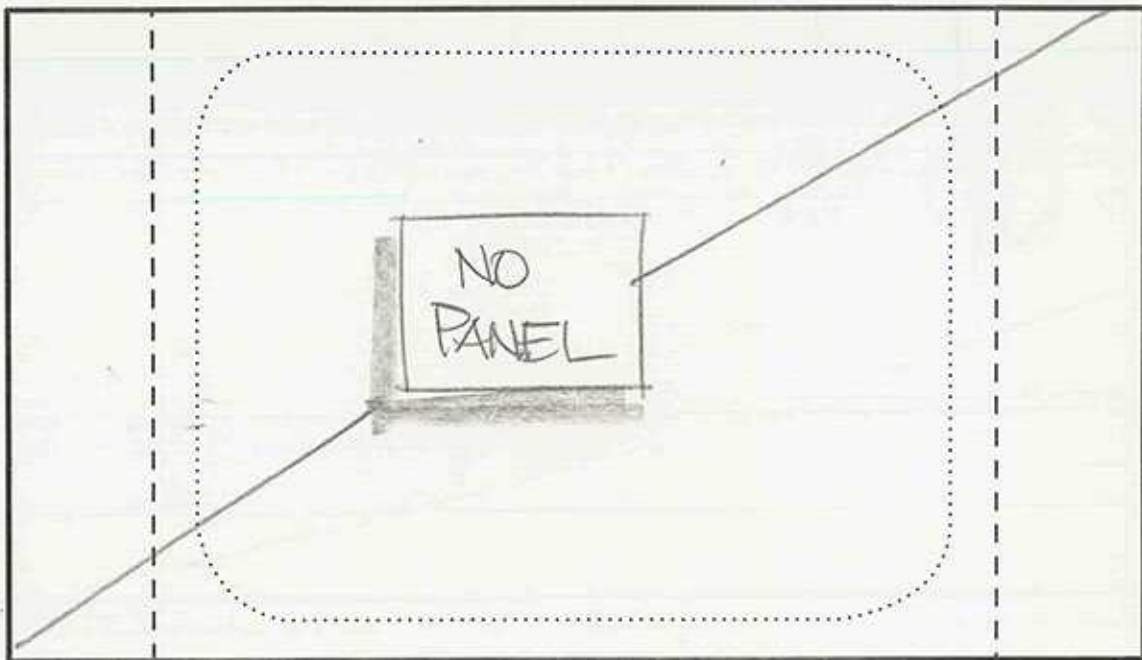

CUT

Dialogue Action

WIDE ON THE TRUCKS. RED & PETROL SETTLE IN SCENE. CRABBY IS SQUIRTING RED, PETROL SQUIRTS CRABBY

(42A) RED/CRABBY/PETROL:  
<LAUGHING!>

Dialogue Action

257-786





# FIREHOUSE TALES

©2005 Warner Bros. This Material is the PROPERTY OF WARNER BROS. TELEVISION ANIMATION. It is unpublished and must not be taken from the studio, duplicated or used in any manner, except for production purposes, and may not be sold or transferred.

Sc. 60 CONTD.

S/A. 42 Panel 1

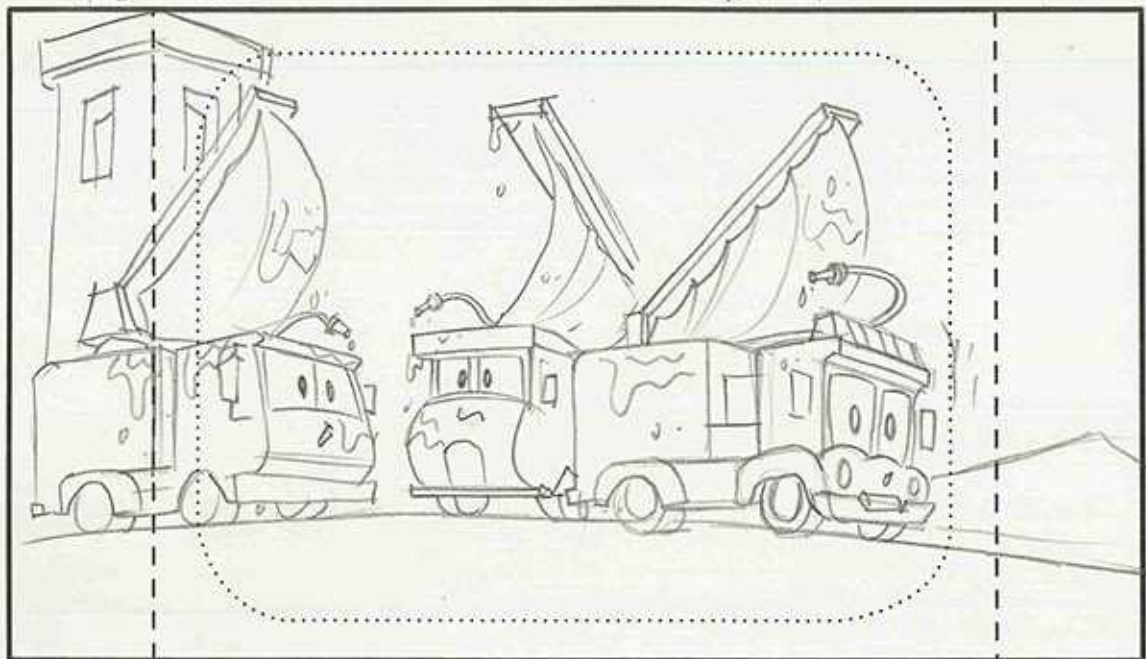

**Action** WIDE ON THE TRUCKS. THEY REACT TO THE ALARM BELL. THEY'VE STOP HORSING AROUND.

EFX: (S/T WATER DRIPS)

SFX: (ALARM RINGING) (OS)

CUT

Dialogue

---

---

Sc.

Panel

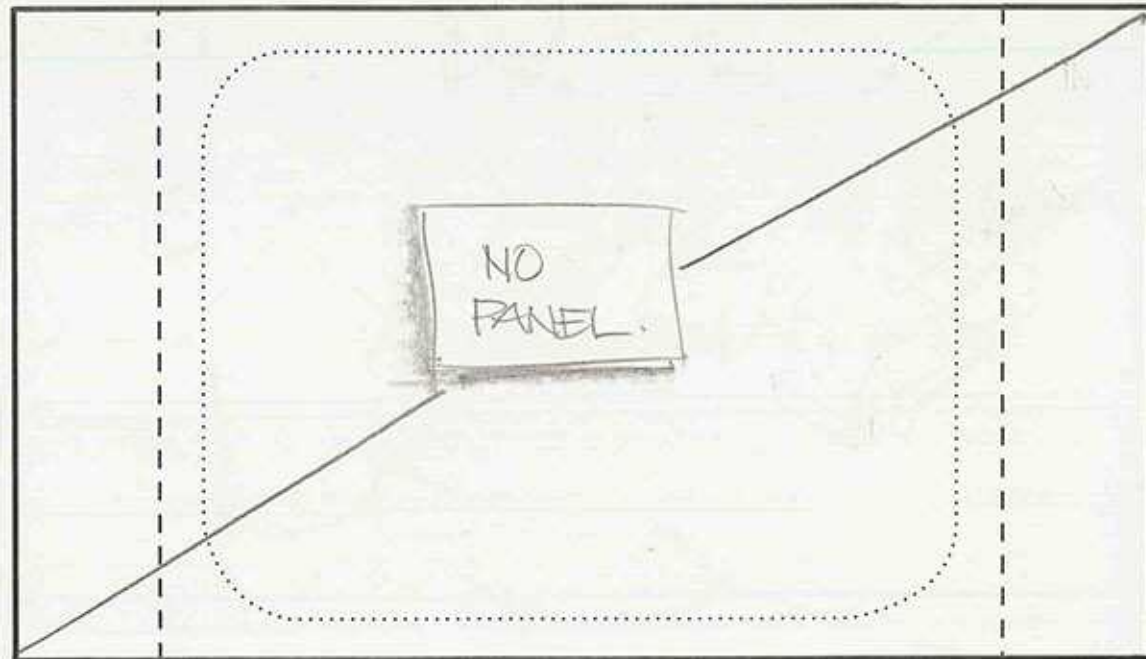

**Action**

Dialogue

---

---





# FIREHOUSE TALES

©2005 Warner Bros. This Material is the PROPERTY OF WARNER BROS. TELEVISION ANIMATION. It is unpublished and must not be taken from the studio, duplicated or used in any manner, except for production purposes, and may not be sold or transferred.

Sc. 61

Panel

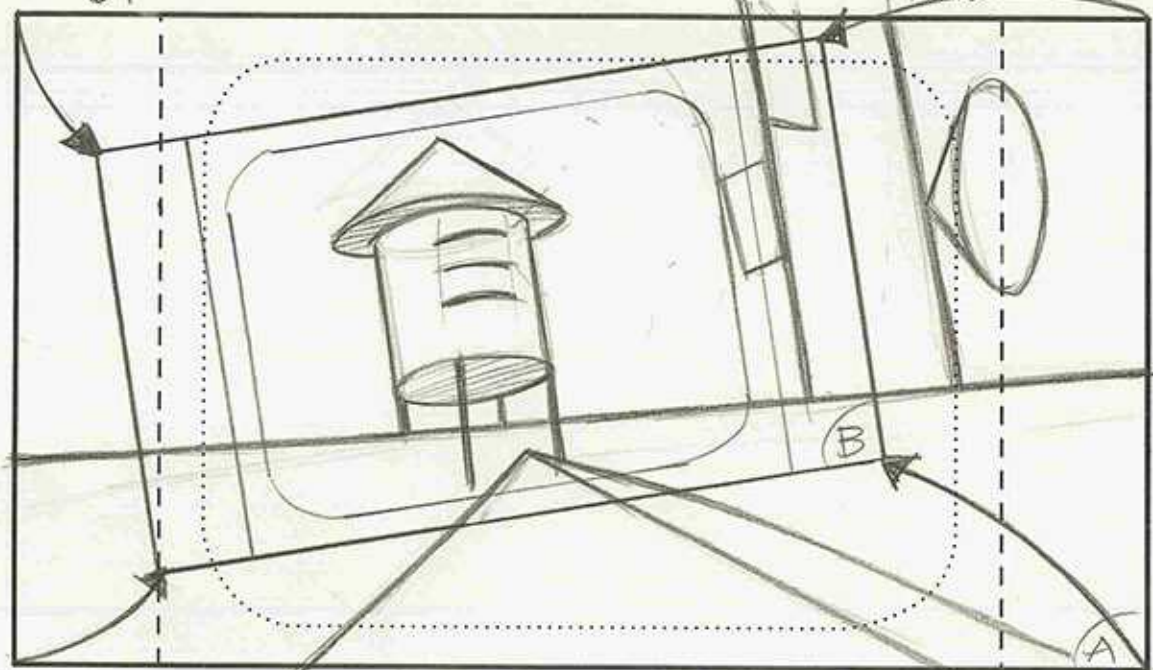

CUT

**Action** ANGLE ON SPEAKER.  
SLOW ROTATE IN (A) → (B)

**Dialogue** (43) CHAT:  
I JUST GOT A CALL FROM TANK, HE'S STRANDED  
OUT IN THE COUNTRY WITH FOUR FLAT TIRES.

Sc. 62

Panel

(A)

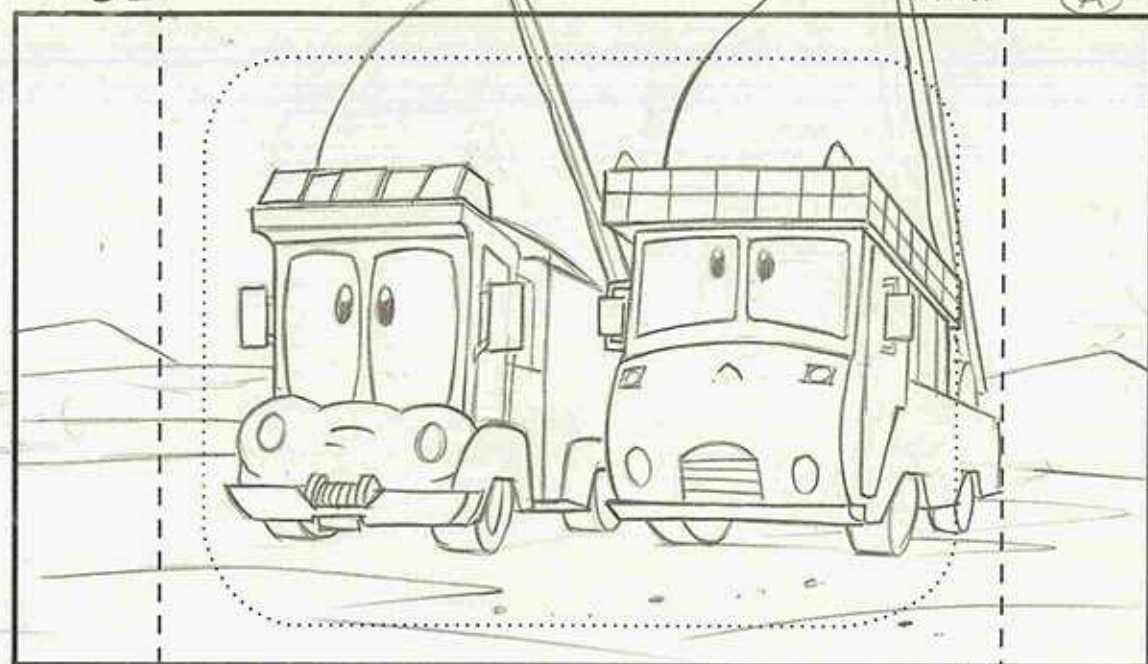

CUT

**Action** EXT. PRACTICE AREA - ANGLE ON RED & PETROL

**Dialogue** (43) CHAT: (OS) (CONTD)  
..BUT THERE'S NOT ENOUGH GAS LEFT IN ALL OF  
GREEN MEADOWS FOR ANYONE TO DRIVE TO HIM!





# FIREHOUSE TALES

©2005 Warner Bros. This Material is the PROPERTY OF WARNER BROS. TELEVISION ANIMATION. It is unpublished and must not be taken from the studio, duplicated or used in any manner, except for production purposes, and may not be sold or transferred.

Sc. 62 CONTD.

Panel (B)

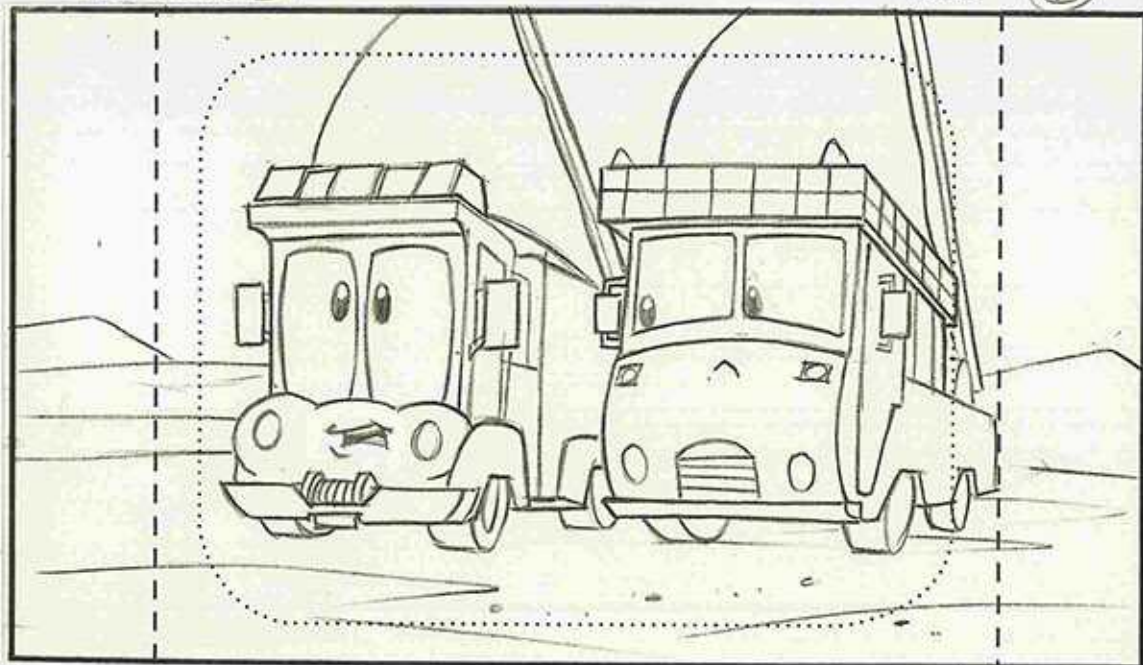

Dialogue Action

(44) RED: (PROUDLY).  
THAT'S OKAY, CHAT. WE DON'T NEED ANY GAS.

Sc. CONTD.

Panel (C)

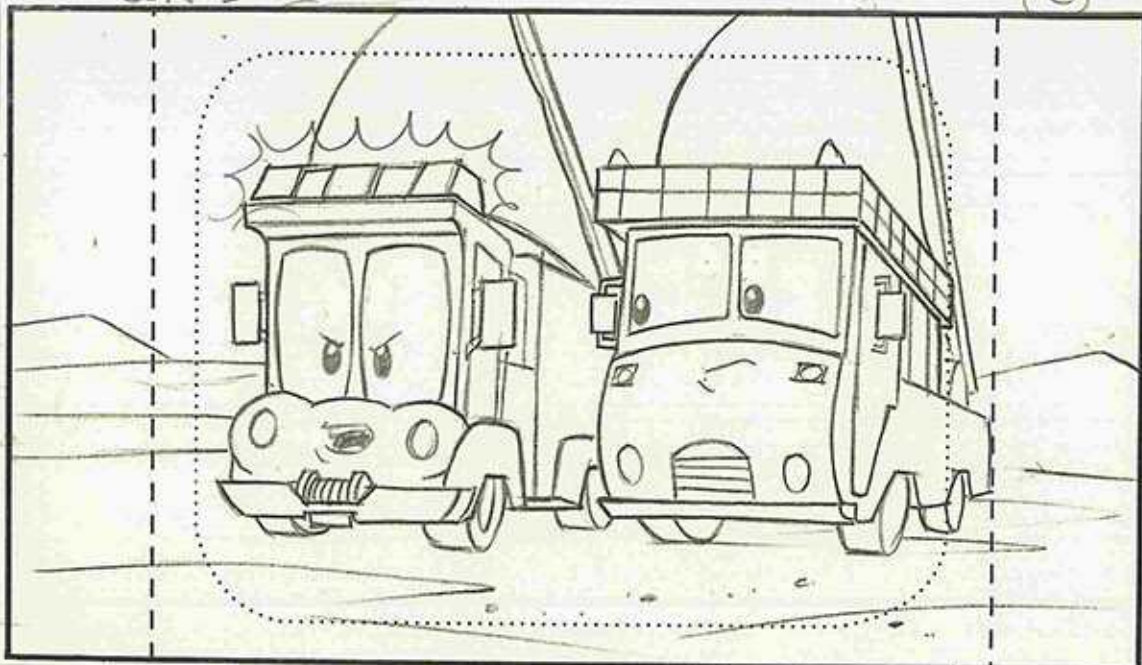

Dialogue Action

RED LOOKS DETERMINED AS HE TURNS ON HIS SIREN.

SFX: (SIREN) EFX: (BOT. LITE LIGHT)

(45) RED:  
THE SIRENS SAY, LET'S SAIL AWAY!

CUT





# FIREHOUSE TALES

©2005 Warner Bros. This Material is the PROPERTY OF WARNER BROS. TELEVISION ANIMATION. It is unpublished and must not be taken from the studio, duplicated or used in any manner, except for production purposes, and may not be sold or transferred.

Sc. 63

Panel

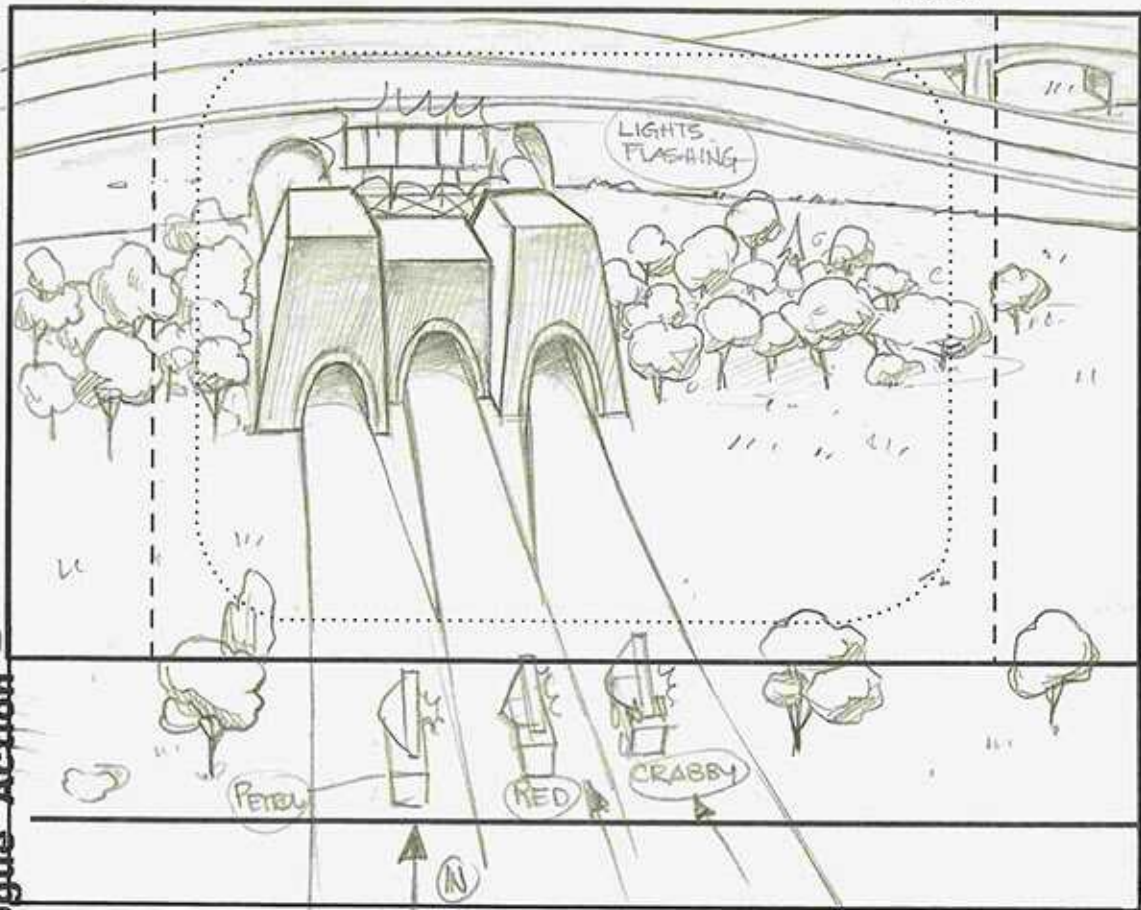

Dialogue Action

ANGLE ON TUNNEL ENTRANCE. RED, SIRENS BLAZING & LIGHTS FLASHING RACE IN, FOLLOWED BY PETROL & CRABBY. THEY HEAD TOWARDS THE TUNNEL

(45A) RED/PETROL/CRABBY:

<LAUGHS>

X-DISS



Sc. 64

Panel

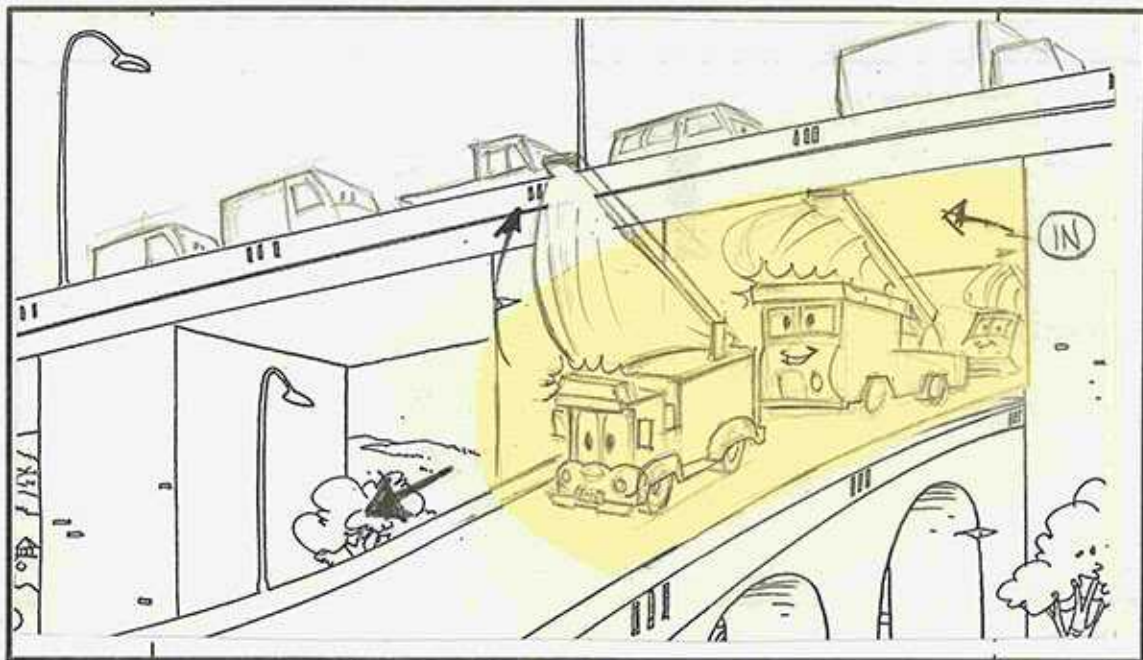

Dialogue Action

EXT. BRIDGE / OVER & UNDER THE TRUCKS DRIVE THROUGH SCENE, SIRENS BLARING & LIGHTS FLASHING - SFX: (SIRENS) EFX: (BOT. LITE LIGHTS)

(46) WISER: (VO)

SO THE TRUCKS SAILED OUT...

257-786





# FIREHOUSE TALES

©2005 Warner Bros. This Material is the PROPERTY OF WARNER BROS. TELEVISION ANIMATION. It is unpublished and must not be taken from the studio, duplicated or used in any manner, except for production purposes, and may not be sold or transferred.

Sc. 65

Panel

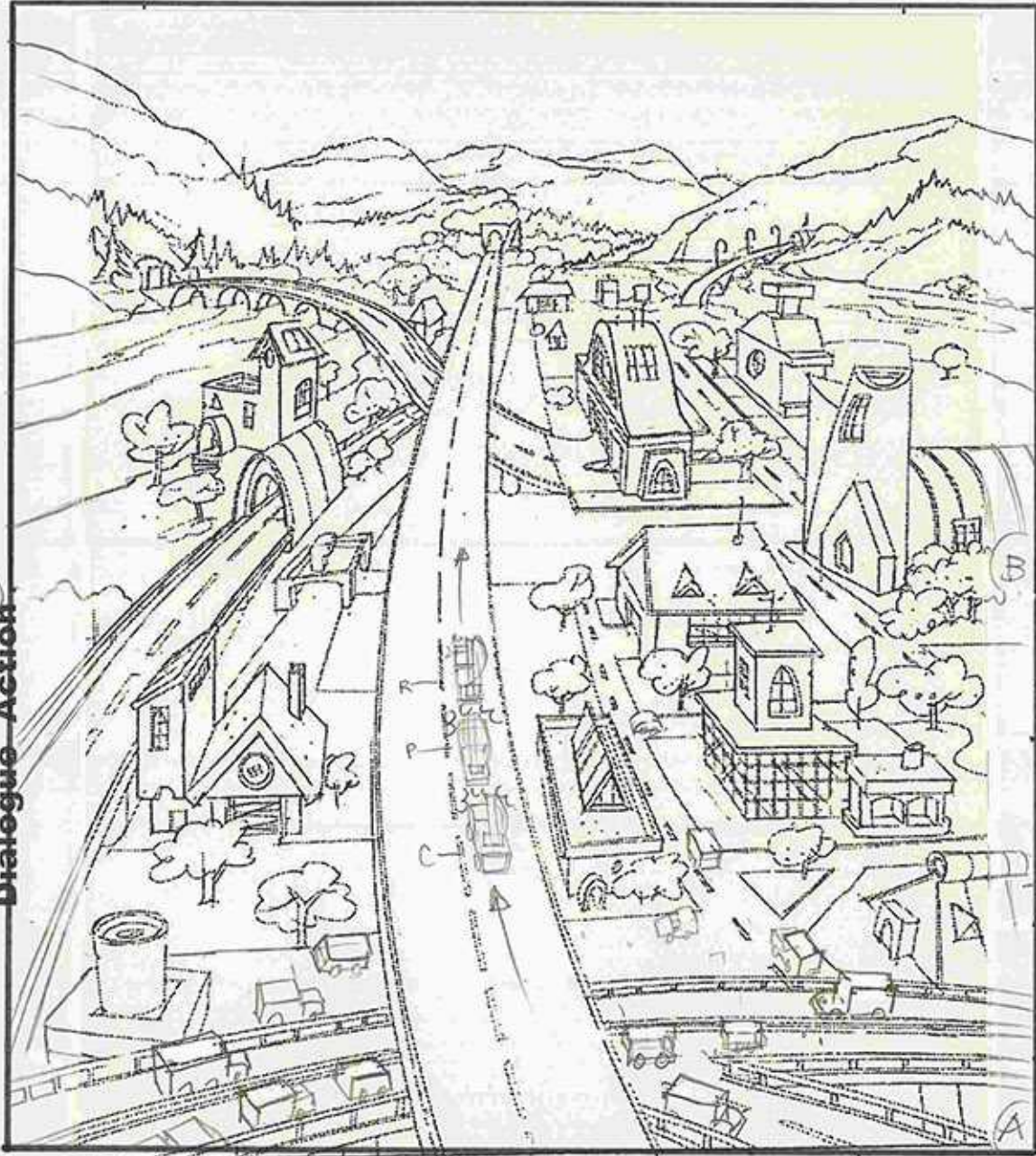

Dialogue Action

Sc.

Panel

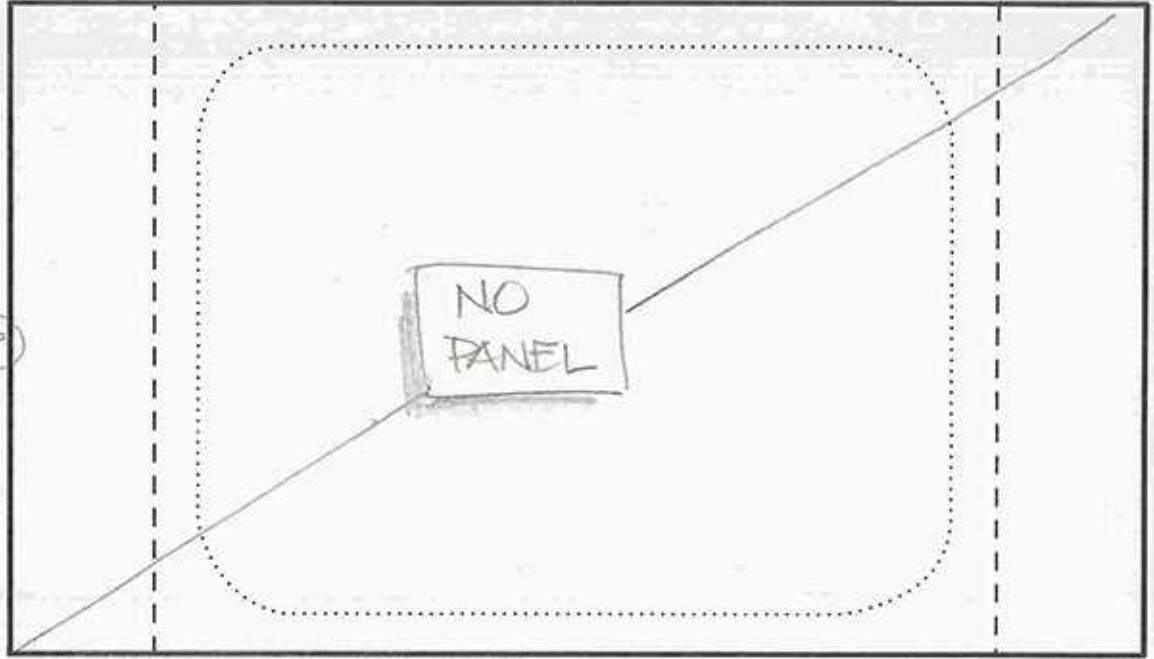

PAN Dialogue Action

EXT BRIDGES WIDE-DAY.

THE TRUCKS SAIL DOWN THE ROAD TOWARDS THE HILLY COUNTRYSIDE.

SFX: <SIREN> EFX: (BOT. LITE LIGHT)

(46) WISER: (VO) (CONTD)

.. TO THE COUNTRY TO FIND TANK.





# FIREHOUSE TALES

©2005 Warner Bros. This Material is the PROPERTY OF WARNER BROS. TELEVISION ANIMATION. It is unpublished and must not be taken from the studio, duplicated or used in any manner, except for production purposes, and may not be sold or transferred.

Sc. 60

Panel

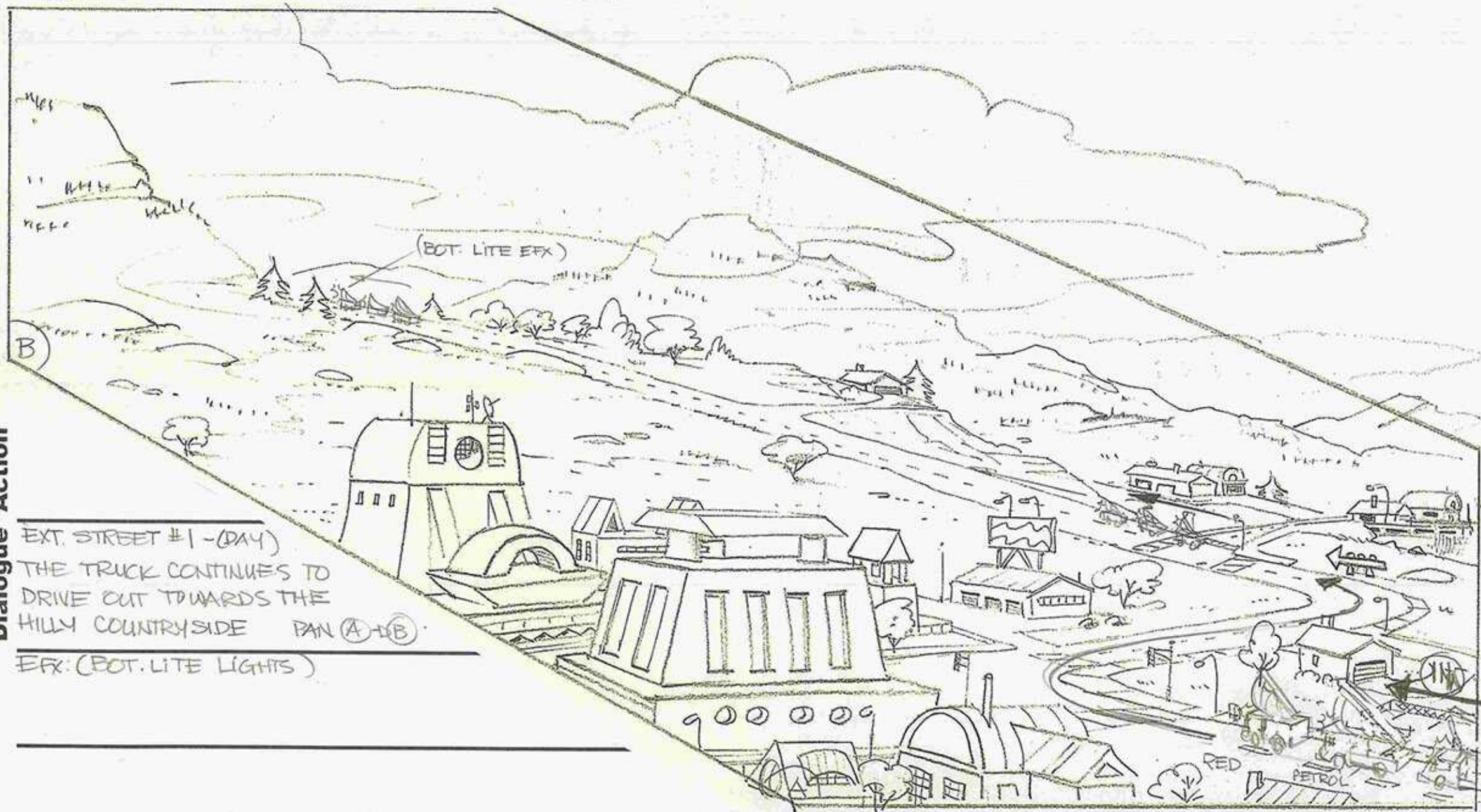

Dialogue Action

EXT. STREET #1 - (DAY)  
THE TRUCK CONTINUES TO  
DRIVE OUT TOWARDS THE  
HILLY COUNTRYSIDE PAN (A) - (B)  
EFX: (BOT. LITE LIGHTS)

CUT

257-786

CRABBY





# FIREHOUSE TALES

©2005 Warner Bros. This Material is the PROPERTY OF WARNER BROS. TELEVISION ANIMATION. It is unpublished and must not be taken from the studio, duplicated or used in any manner, except for production purposes, and may not be sold or transferred.

Page 66

Sc. 67

Panel (A)

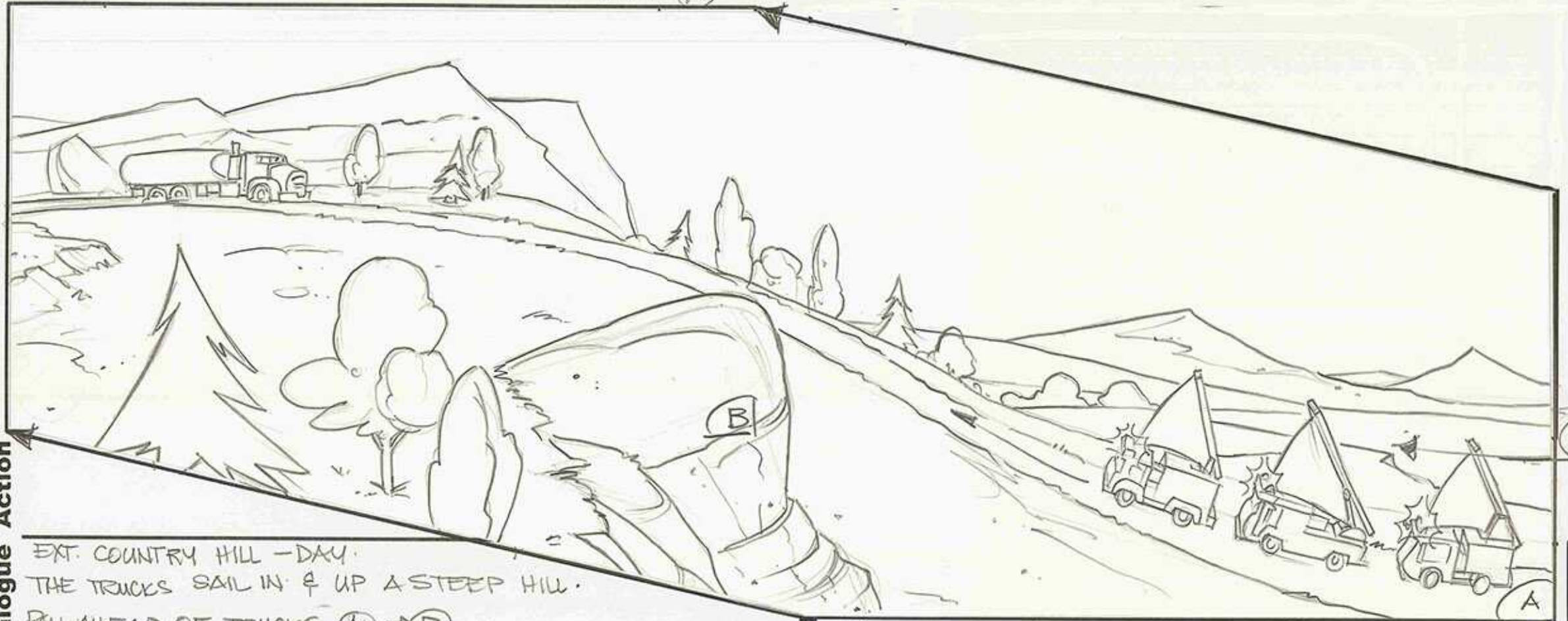

CUT  
Dialogue Action

EXT. COUNTRY HILL - DAY.  
 THE TRUCKS SAIL IN & UP A STEEP HILL.  
 PAN AHEAD OF TRUCKS (A) → (B)  
 EFX: (BOT. LITE LIGHT)

Dia

(THE TRUCKS LIGHTS ARE FLASHING)

257-786





# FIREHOUSE TALES

©2005 Warner Bros. This Material is the PROPERTY OF WARNER BROS. TELEVISION ANIMATION. It is unpublished and must not be taken from the studio, duplicated or used in any manner, except for production purposes, and may not be sold or transferred.

Page 67

Sc. 68 CONTD.

Panel (B)

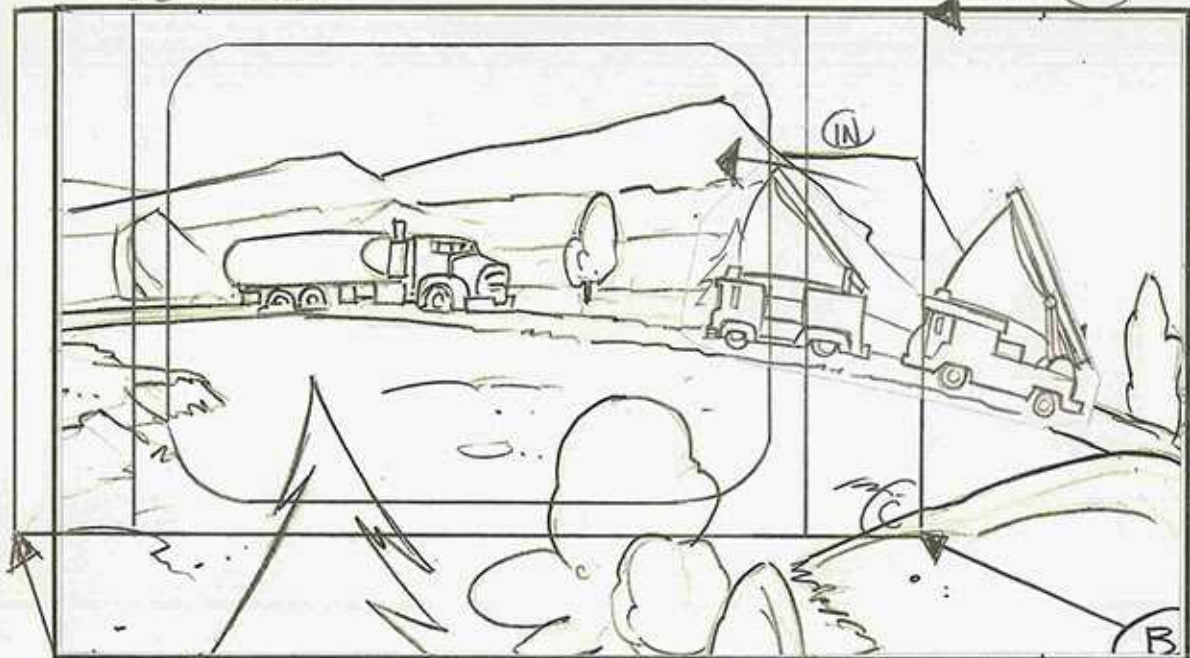

**Dialogue Action** THEY SEE TANK SITTING BY THE SIDE OF THE ROAD WITH FOUR FLAT TIRES. TRUCK IN (B) → (C). RED TURNS HIS LIGHT OFF AS HE ENTERS SCENE.

(HU)  
(CUT)

(47) WISER : (VO) (CONTD)

BUT JUST AS THEY WERE ABOUT TO REACH HIM...

Sc. 69

Panel (A)

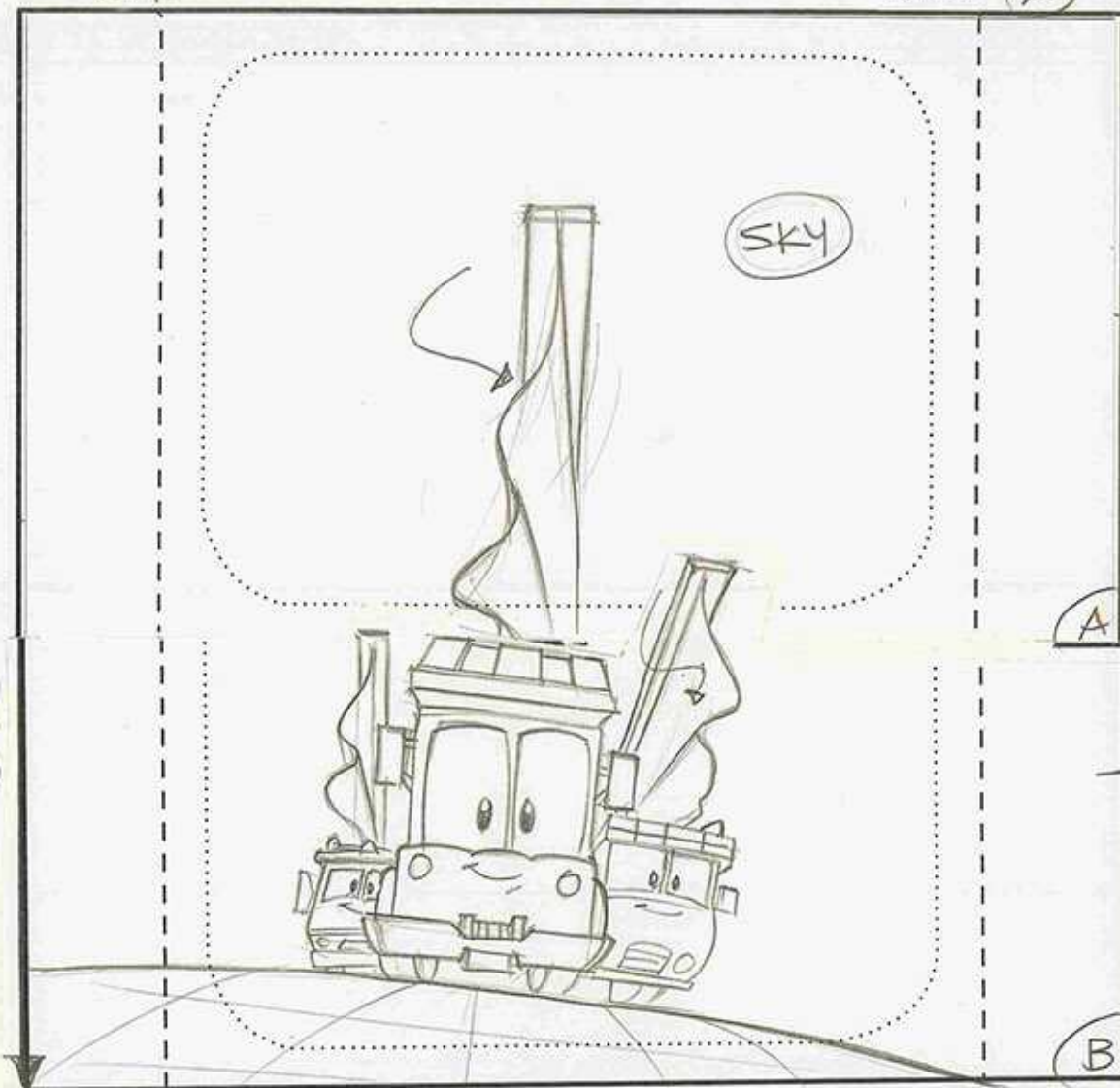

ANGLE ON SAIL. IT DEFLATES. PAN (A) → (B)

(START)

(PAN)

(STOP)

257-786





# FIREHOUSE TALES

©2005 Warner Bros. This Material is the PROPERTY OF WARNER BROS. TELEVISION ANIMATION. It is unpublished and must not be taken from the studio, duplicated or used in any manner, except for production purposes, and may not be sold or transferred.

Sc. 69. CONTD.

Panel (B)

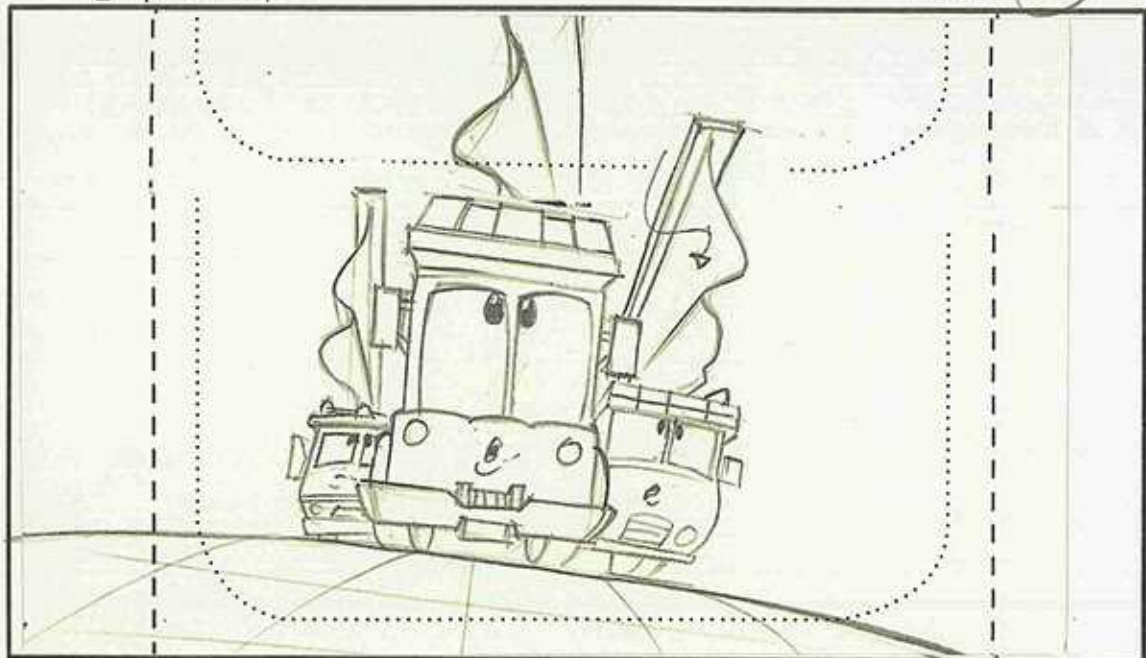

**Dialogue Action**  
THE TRUCKS REALIZING THAT THE WIND HAS DIED  
LOOK UP AT THEIR DEFLATED SAILS

(47) WISER: (VO) (CONTD)  
.. THE WINDS DIED.

Sc. CONTD.

Panel (C)

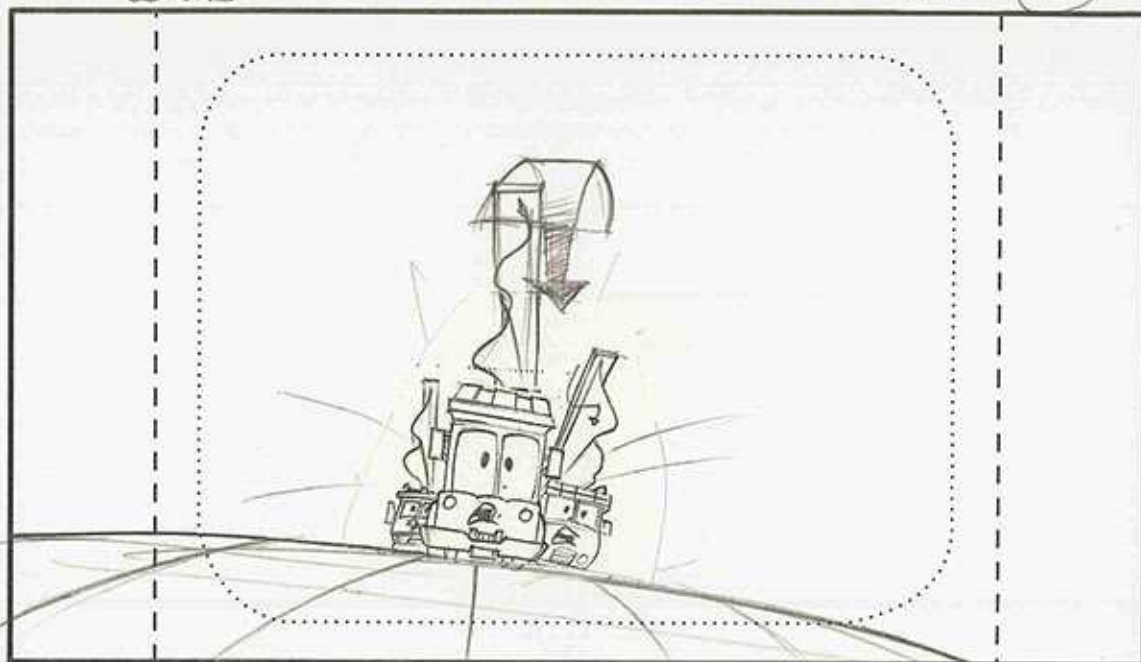

**Dialogue Action**  
THE TRUCKS ROLL BACKWARDS.

(48) RED/PETROL/CRABBY:  
(WHHHHOOAA!)

CUT





# FIREHOUSE TALES

©2005 Warner Bros. This Material is the PROPERTY OF WARNER BROS. TELEVISION ANIMATION. It is unpublished and must not be taken from the studio, duplicated or used in any manner, except for production purposes, and may not be sold or transferred.

Sc. 70

SA 69 Panel

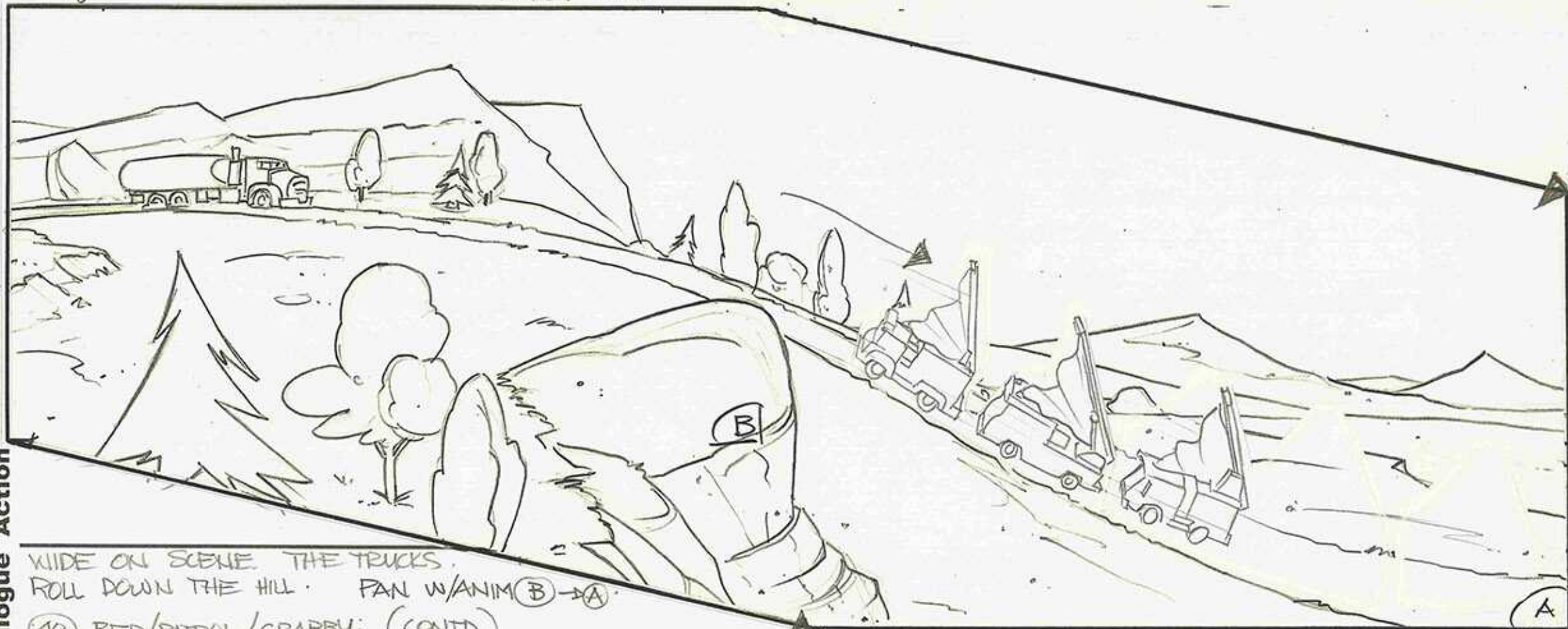

LU  
CUT  
Dialogue Action

WIDE ON SCENE THE TRUCKS ROLL DOWN THE HILL. PAN W/ANIM (B) → (A)

(48) RED/PATROL/CRABBY: (CONTD)  
(WHHH#OOAAA!)

Dia

CUT

257-786





# FIREHOUSE TALES

©2005 Warner Bros. This Material is the PROPERTY OF WARNER BROS. TELEVISION ANIMATION. It is unpublished and must not be taken from the studio, duplicated or used in any manner, except for production purposes, and may not be sold or transferred.

Sc. 71

Panel

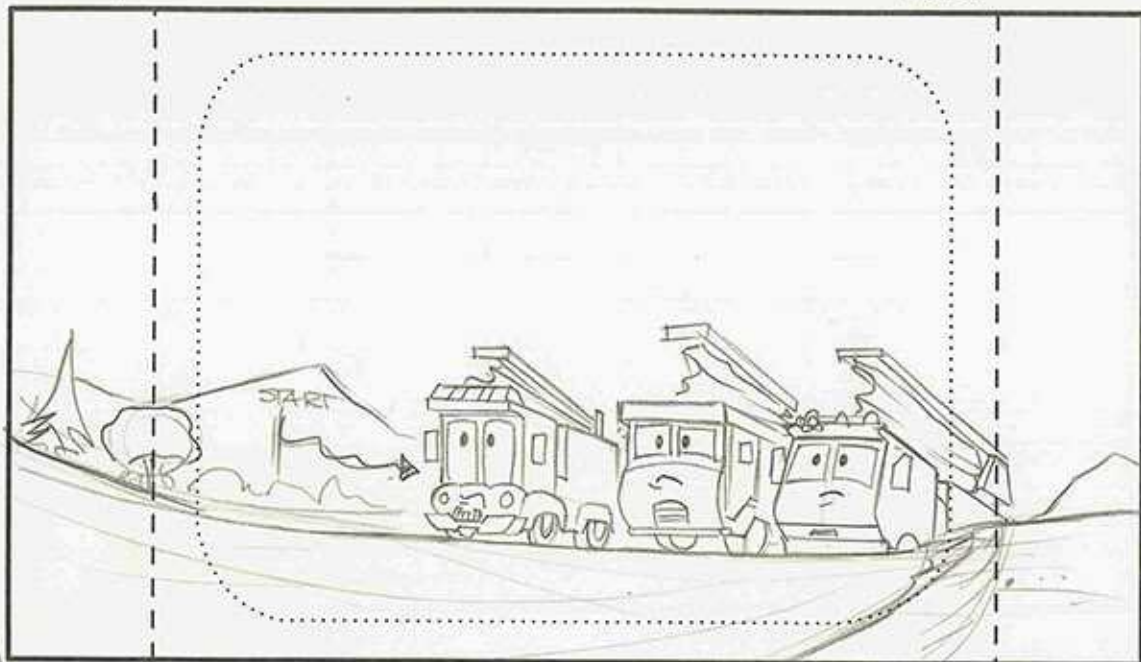

CUT

**Dialogue Action**  
BOTTOM OF HILL.  
THE TRUCKS ROLL TO A STOP. THEIR SAILS ARE DEFLATED.

Sc. 72

Panel

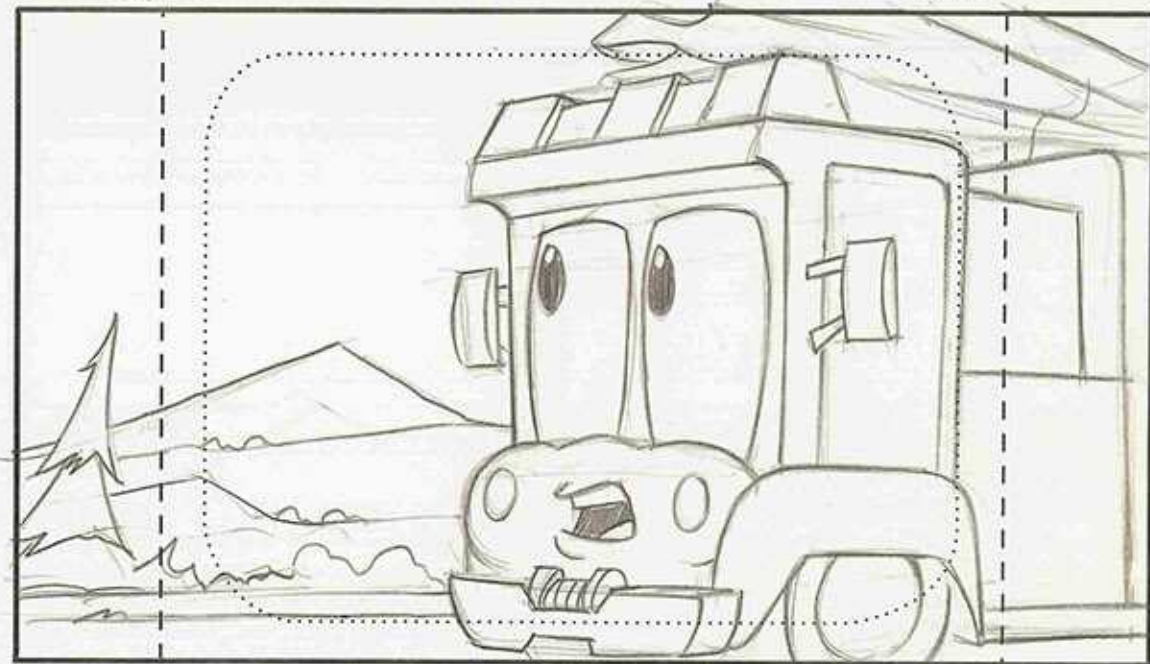

CUT

**Dialogue Action**  
CLOSE ON RED. HE CALLS OUT TO TANK

(49) RED: (YELLING)  
TANK, ARE YOU ALL RIGHT?

CUT

257-786





# FIREHOUSE TALES

©2005 Warner Bros. This Material is the PROPERTY OF WARNER BROS. TELEVISION ANIMATION. It is unpublished and must not be taken from the studio, duplicated or used in any manner, except for production purposes, and may not be sold or transferred.

Sc. 73

Panel

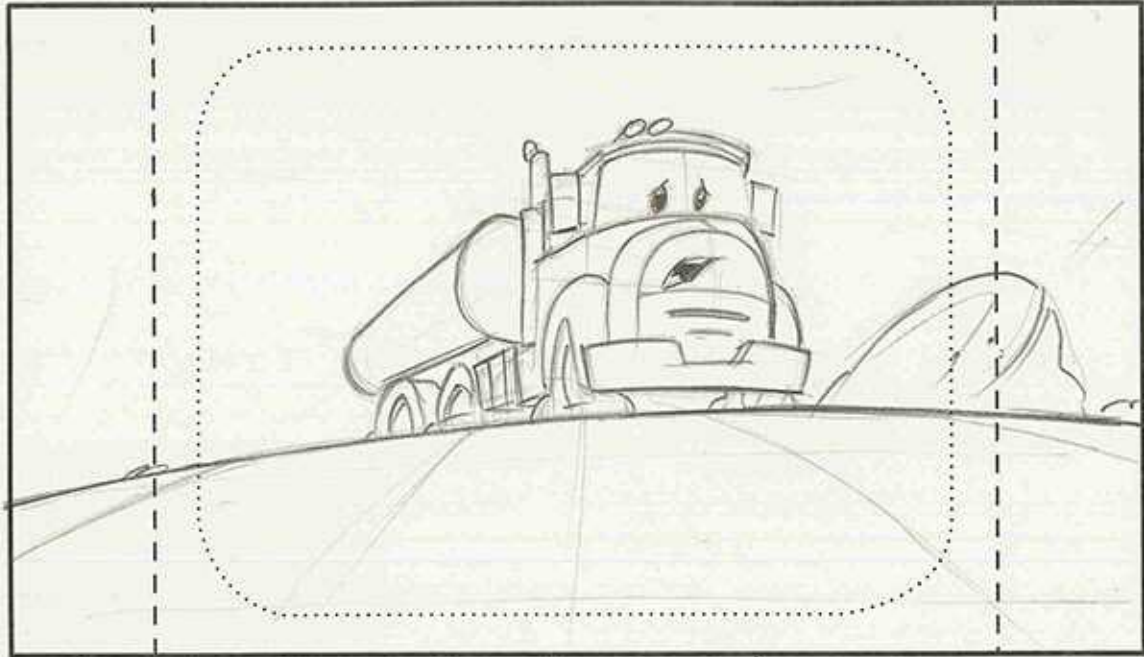

Dialogue Action

ANGLE ON TANK (RED'S P.O.V)

(50) TANK: (CALLS OUT).

I'D BE A LOT BETTER IF I HAD FOUR WORKING TIRES.

Sc. 74

Panel (A)

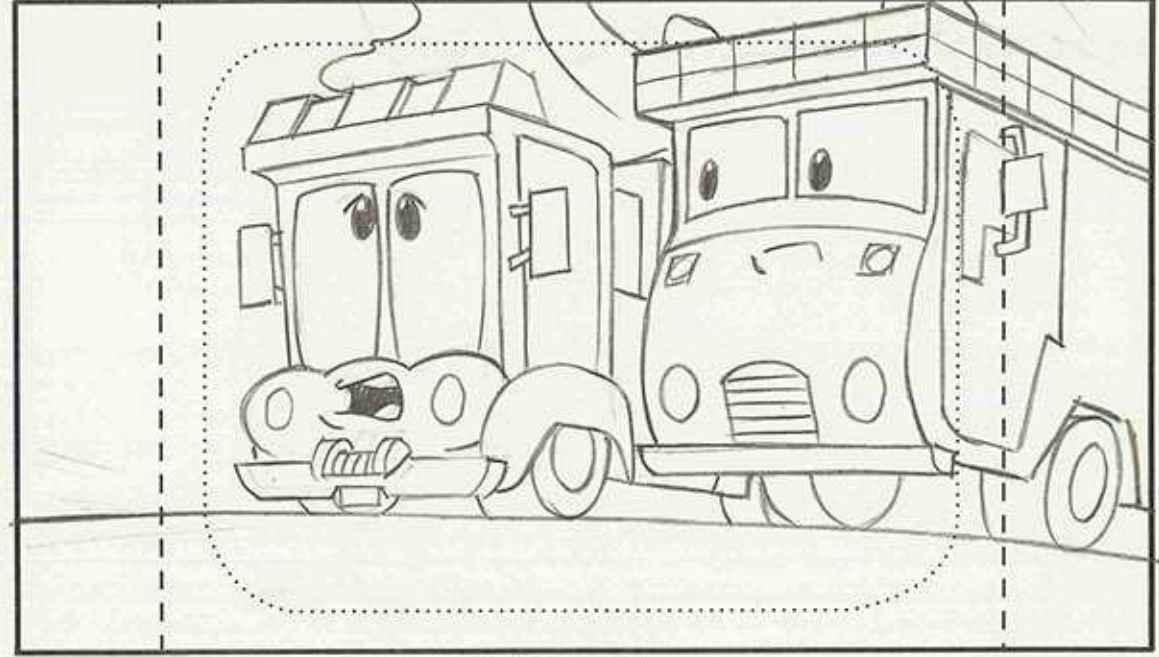

Dialogue Action

ANGLE ON RED & PETROL.

(51) RED: (YELLING)

DONT WORRY, WE'LL BE RIGHT OVER AS SOON AS THE WIND PICKS UP.

CUT





# FIREHOUSE TALES

©2005 Warner Bros. This Material is the PROPERTY OF WARNER BROS. TELEVISION ANIMATION. It is unpublished and must not be taken from the studio, duplicated or used in any manner, except for production purposes, and may not be sold or transferred.

Sc. 74 (CONTD)

Panel (B)

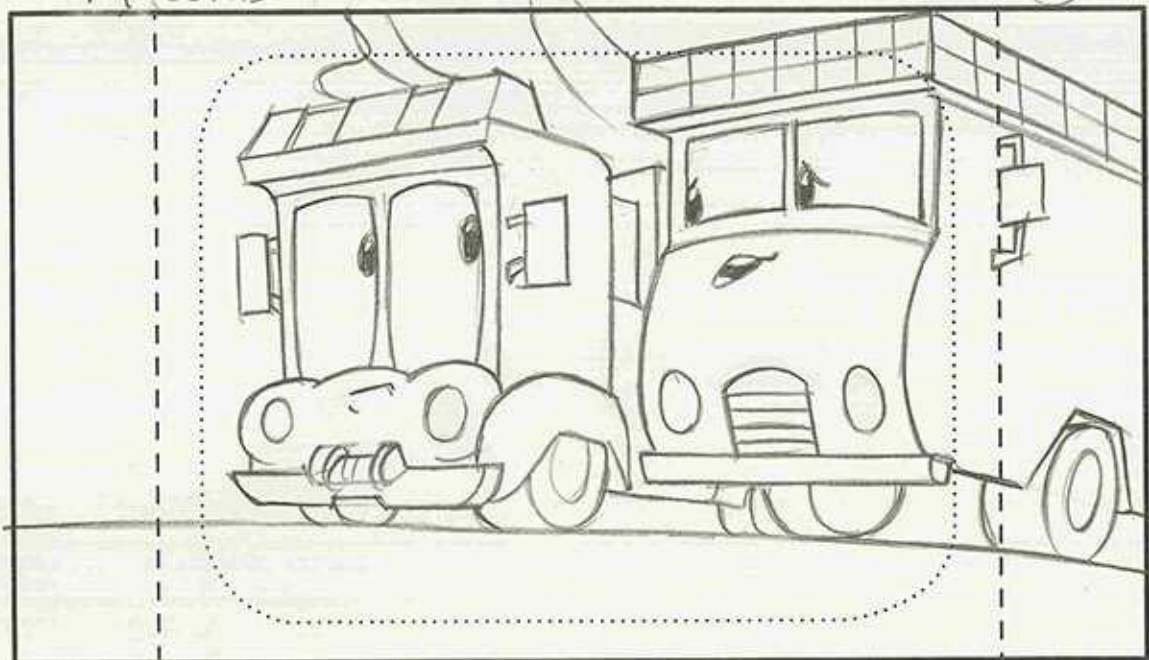

Dialogue Action

PETROL LOOKS WORRIED -

(52) PETROL: (SOFTLY)

BUT RED, WHAT IF THERE ISN'T ANY MORE WIND?

Sc. CONTD

Panel (C)

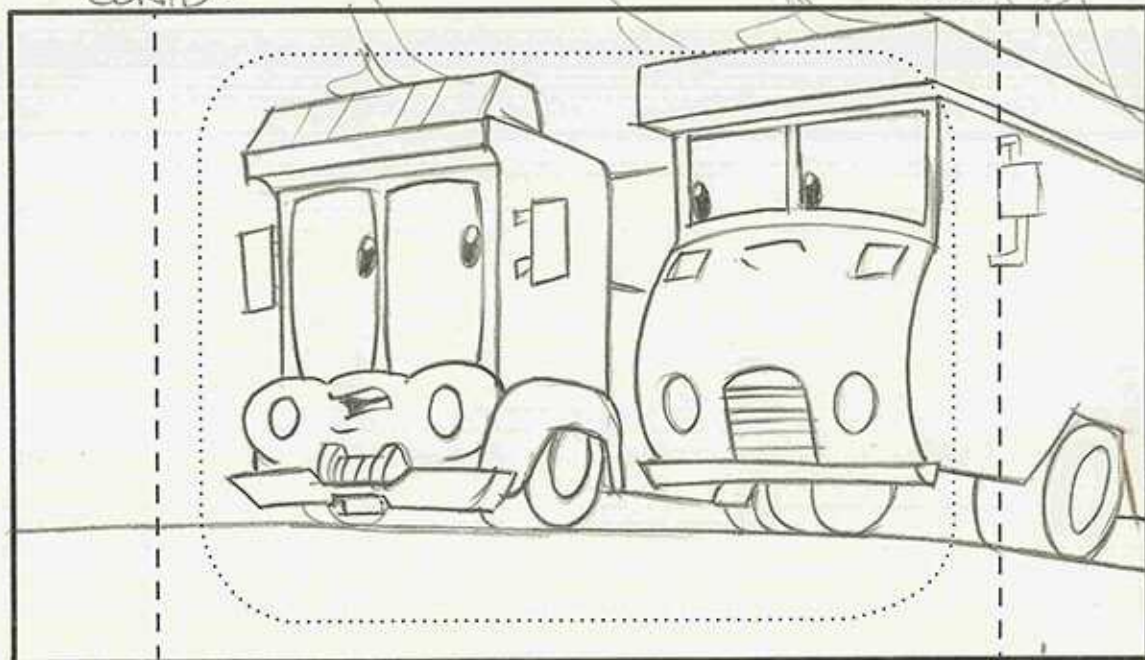

Dialogue Action

(53) RED:

I GUESS, WE'LL HAVE TO COME UP WITH SOMETHING ELSE.





# FIREHOUSE TALES

©2005 Warner Bros. This Material is the PROPERTY OF WARNER BROS. TELEVISION ANIMATION. It is unpublished and must not be taken from the studio, duplicated or used in any manner, except for production purposes, and may not be sold or transferred.

Sc. 74 CONTD.

Panel (D)

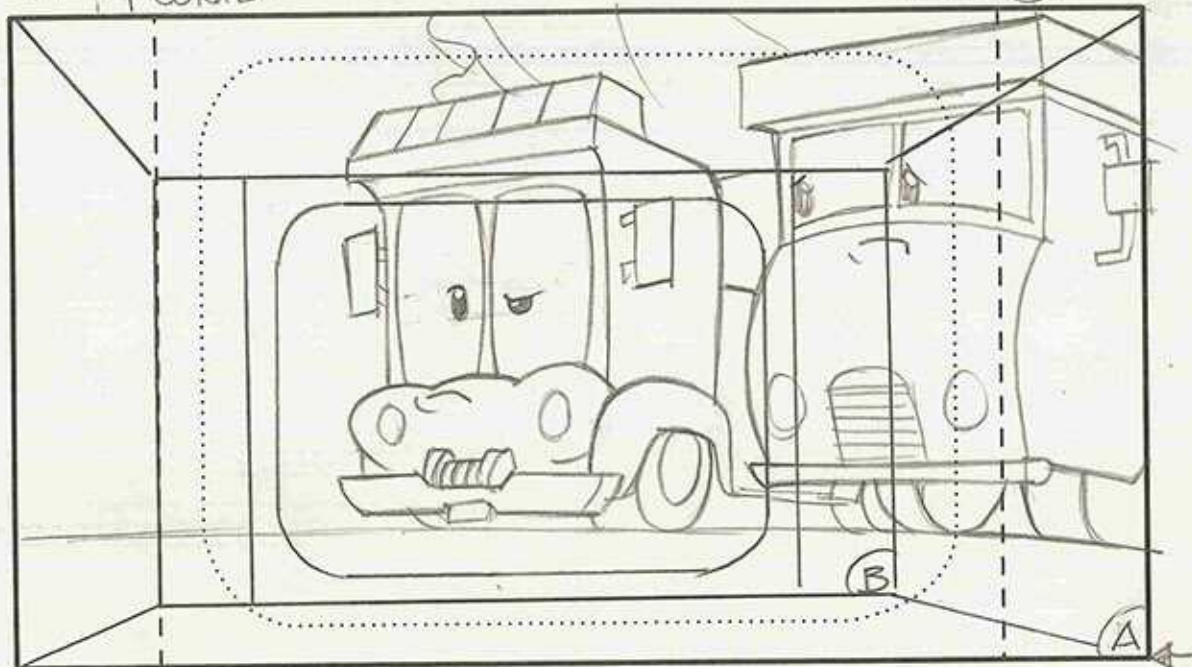

Dialogue Action

TRUCK IN (A) → (B) RED IS THINKING

Sc. CONTD.

Panel (E)

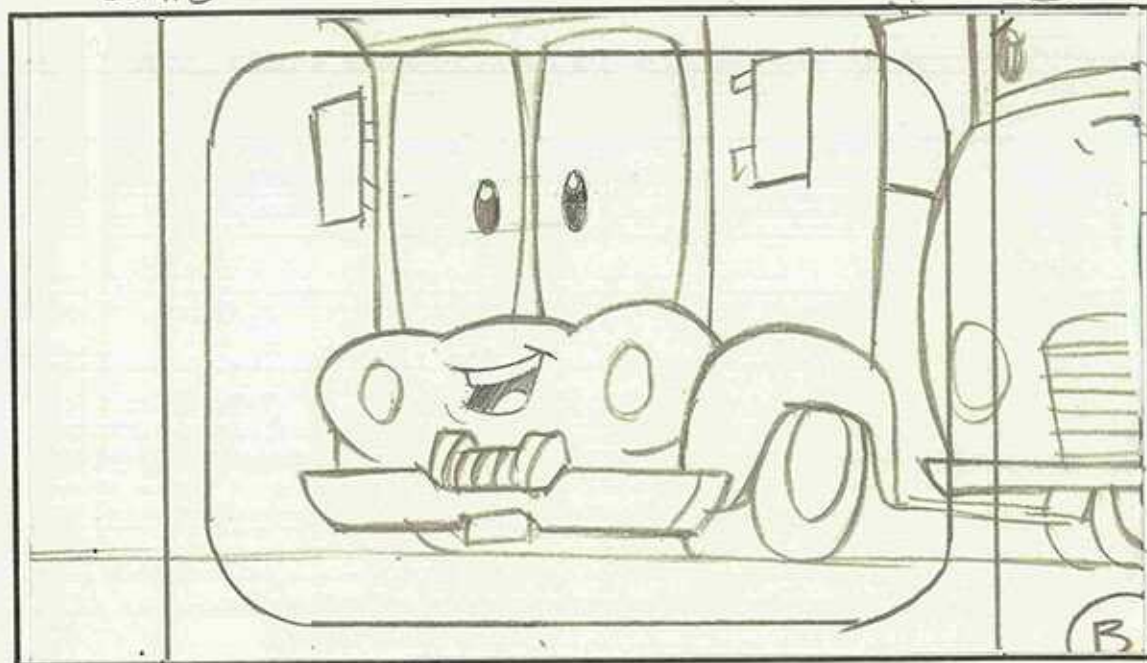

Dialogue Action

RED HAS AN EPIPHANY!

(53) RED: (CONTD)

I KNOW!





# FIREHOUSE TALES

©2005 Warner Bros. This Material is the PROPERTY OF WARNER BROS. TELEVISION ANIMATION. It is unpublished and must not be taken from the studio, duplicated or used in any manner, except for production purposes, and may not be sold or transferred.

Sc. 74 (CONTD)

Panel (F)

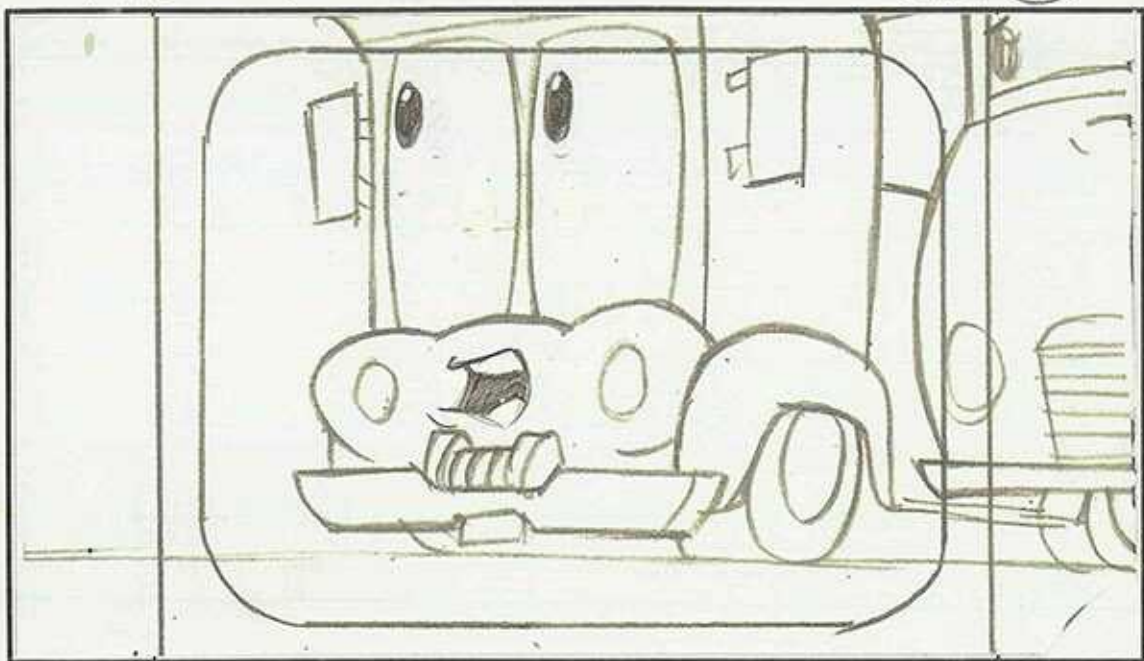

Dialogue Action

RED CALLS OUT TO (OS) TANK

(CUT)

(53) RED: (CONTD)

"TANK"

Sc.

Panel

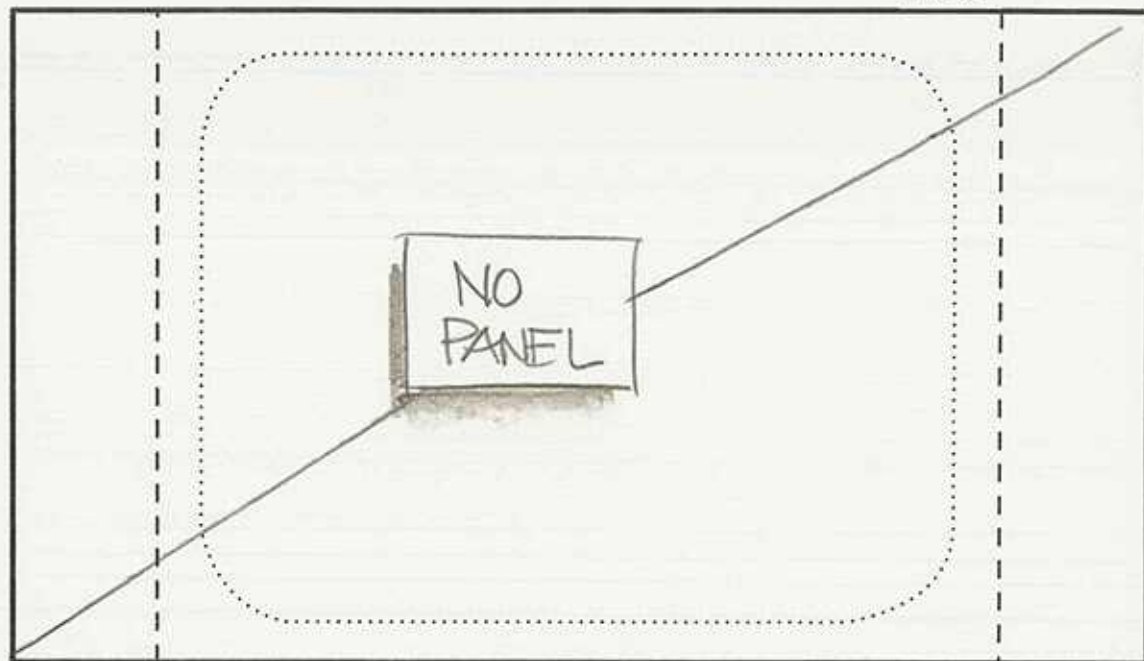

Dialogue Action





# FIREHOUSE TALES

©2005 Warner Bros. This Material is the PROPERTY OF WARNER BROS. TELEVISION ANIMATION. It is unpublished and must not be taken from the studio, duplicated or used in any manner, except for production purposes, and may not be sold or transferred.

Sc. 75

Panel

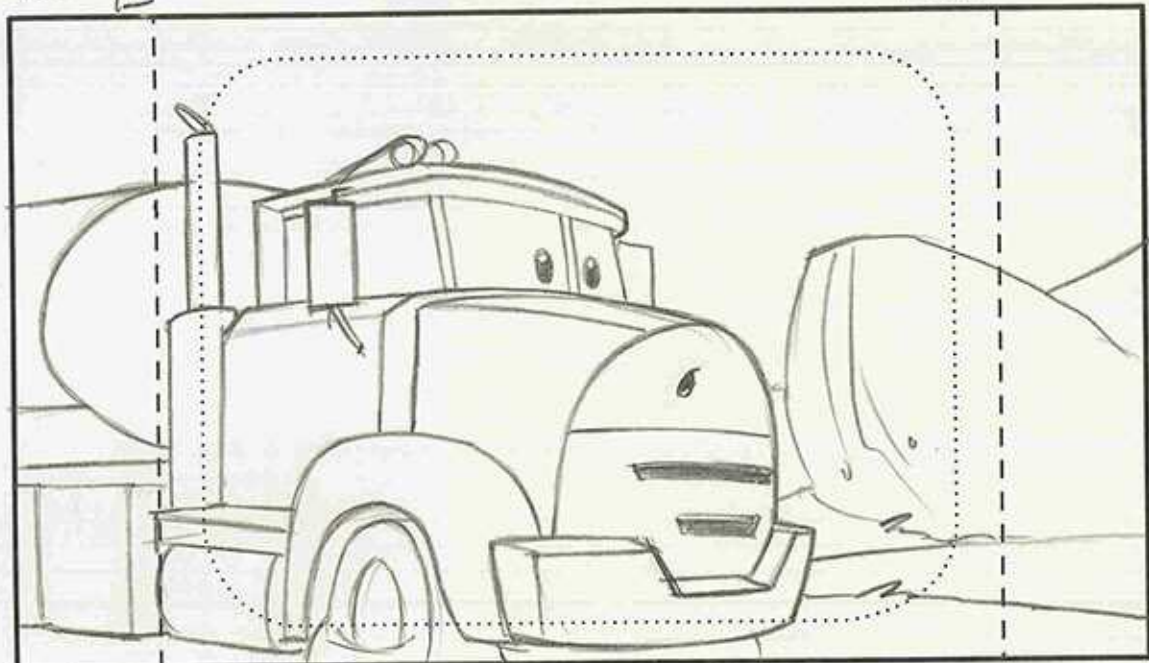

CUT

Dialogue Action

ANGLE ON TANK, LOOKING PERPLEXED.

(53) RED: (VO) (CONTD)

GET READY, HERE IT COMES!

Sc.

CONTD.

Panel

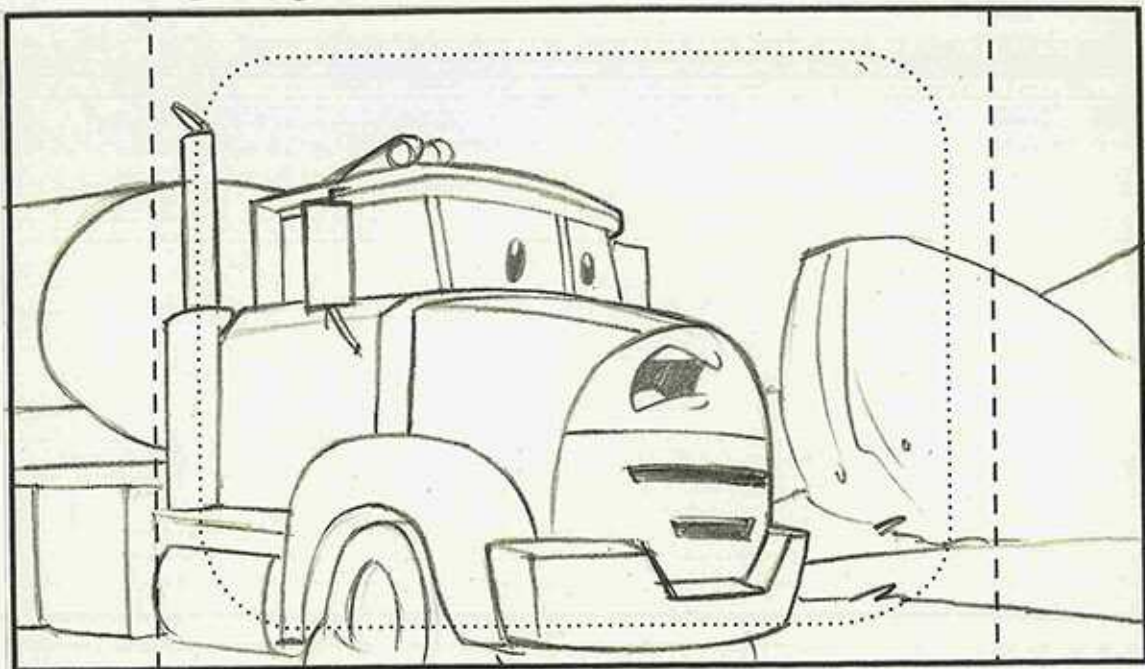

Dialogue Action

NOW HE LOOKS CONFUSED.

(54) TANK: (CONFUSED)

HERE WHAT COMES?





# FIREHOUSE TALES

©2005 Warner Bros. This Material is the PROPERTY OF WARNER BROS. TELEVISION ANIMATION. It is unpublished and must not be taken from the studio, duplicated or used in any manner, except for production purposes, and may not be sold or transferred.

Sc. 76.

Panel (A)

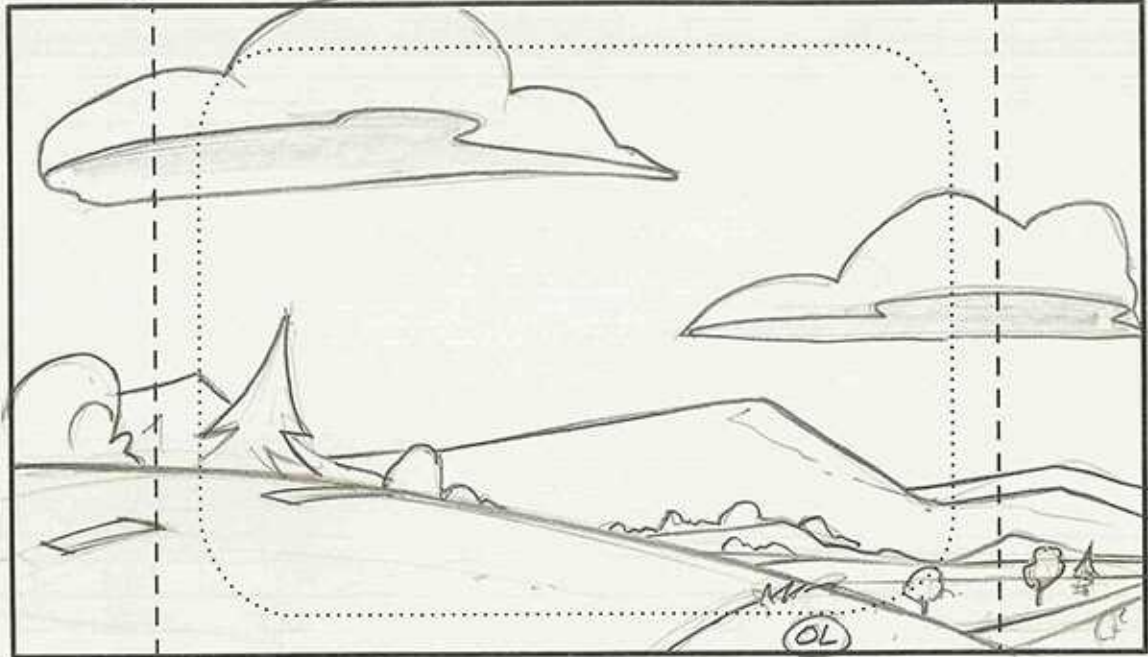

Dialogue Action

TANK'S P.O.V. ON THE CREST OF THE HILL.

Sc. CONTD.

Panel (B)

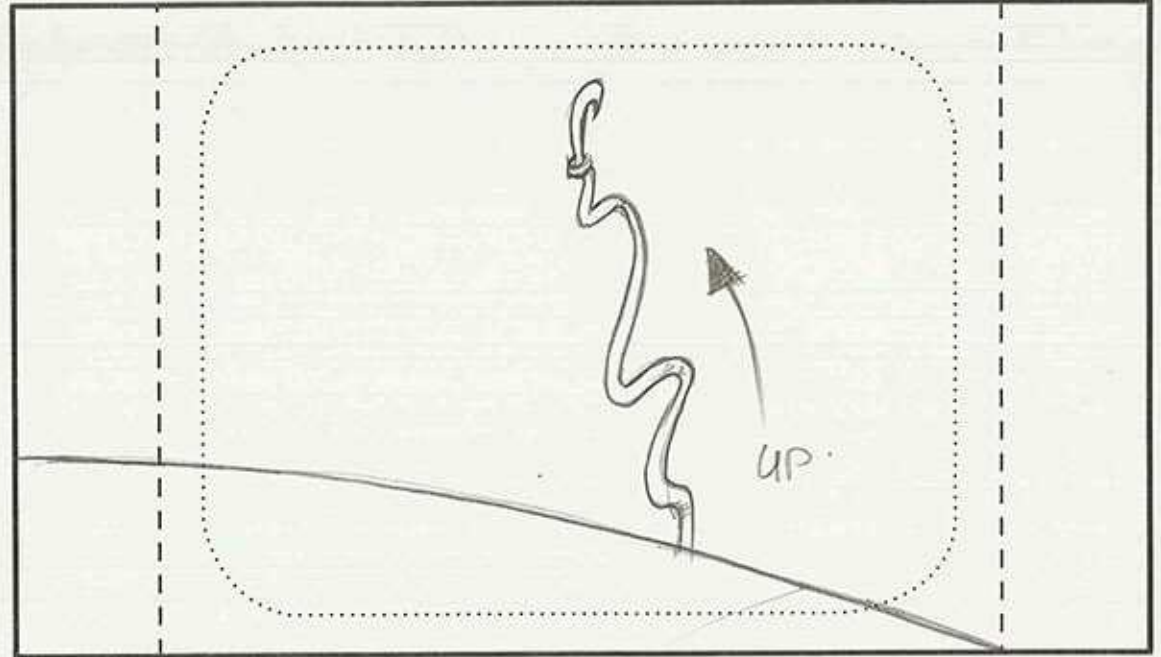

Dialogue Action

RED HOOK FLIES UP OVER THE CREST OF THE HILL.

CUT





# FIREHOUSE TALES

©2005 Warner Bros. This Material is the PROPERTY OF WARNER BROS. TELEVISION ANIMATION. It is unpublished and must not be taken from the studio, duplicated or used in any manner, except for production purposes, and may not be sold or transferred.

Sc. 77

S/A 76 - Panel

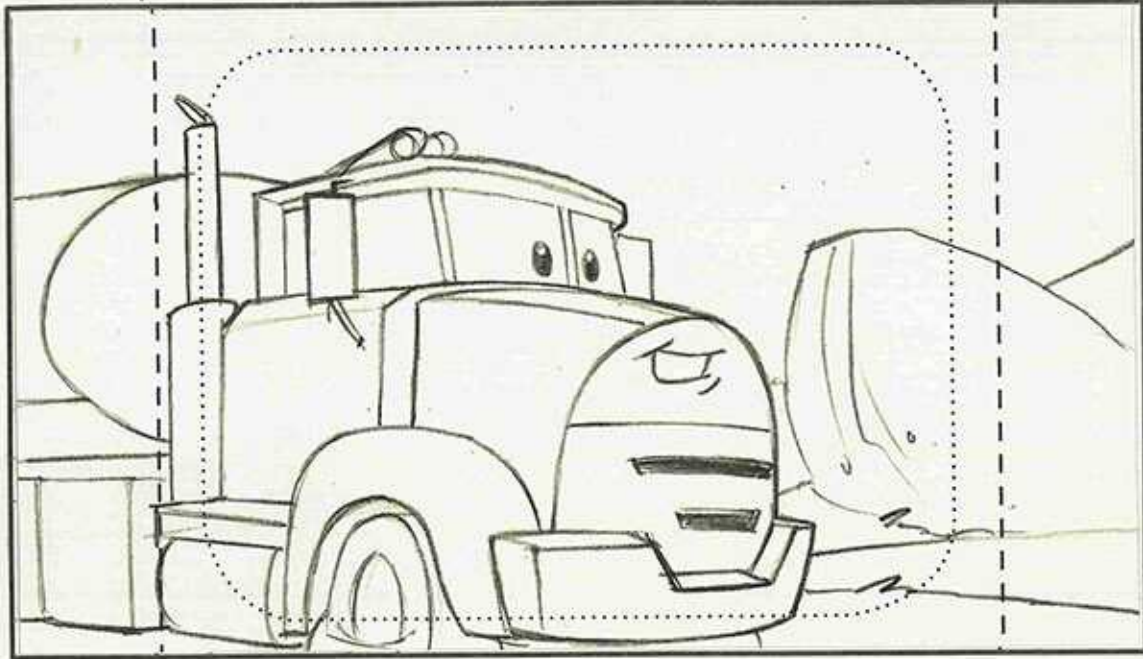

ANGLE ON TANK. HE GETS IT!

Dialogue Action

(55) TANK! (GRINNING)

YEAH!

CUT

Sc. 78

Panel A

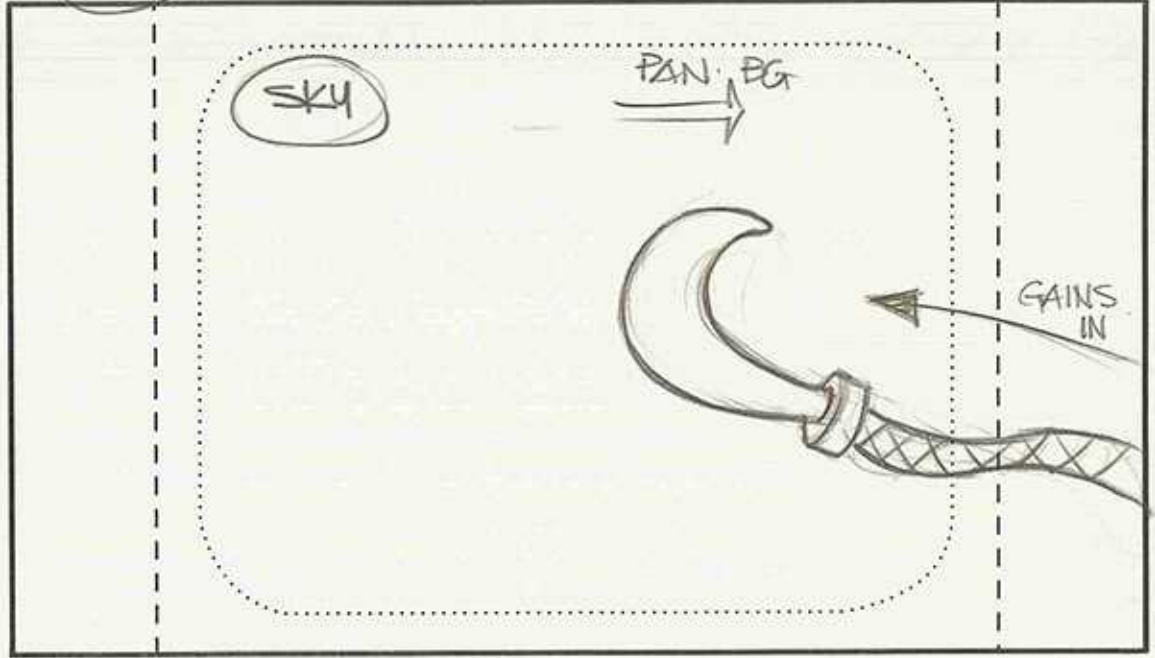

CLOSE ON RED'S HOOK AS IT GAINS INTO SCENE.  
PAN BG

Dialogue Action

257-786





# FIREHOUSE TALES

©2005 Warner Bros. This Material is the PROPERTY OF WARNER BROS. TELEVISION ANIMATION. It is unpublished and must not be taken from the studio, duplicated or used in any manner, except for production purposes, and may not be sold or transferred.

Sc. 79 CONTD.

Panel (B)

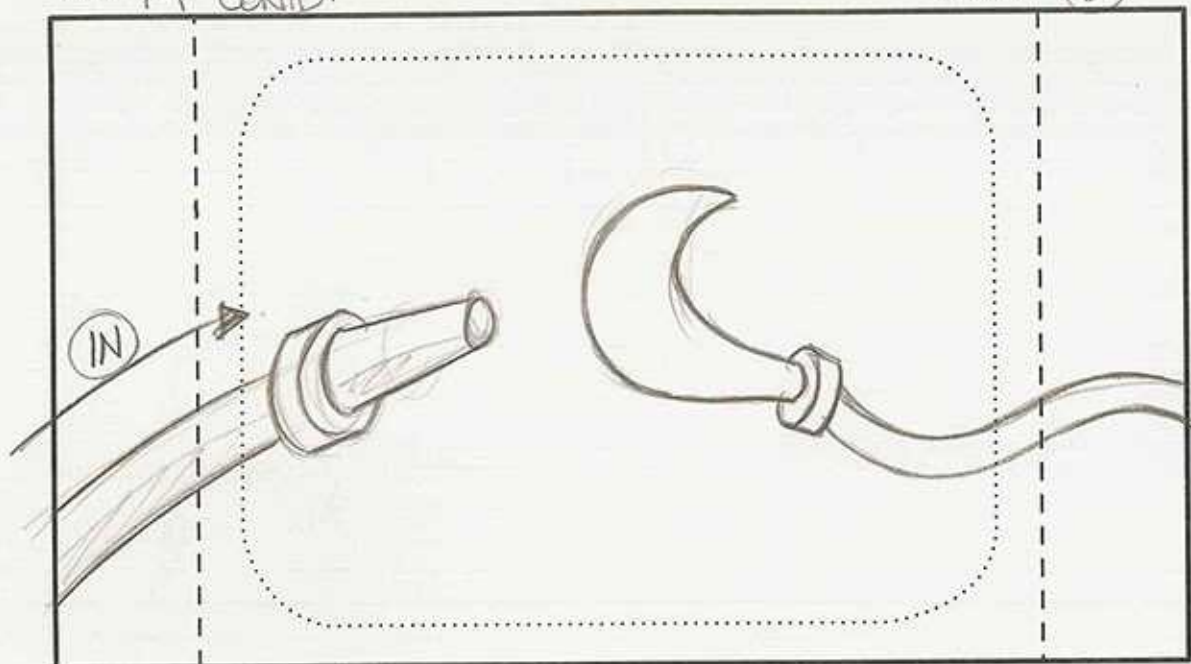

**Dialogue Action**  
TANK'S HOSE IN (STOP PAN)

Sc. CONTD.

Panel (C)

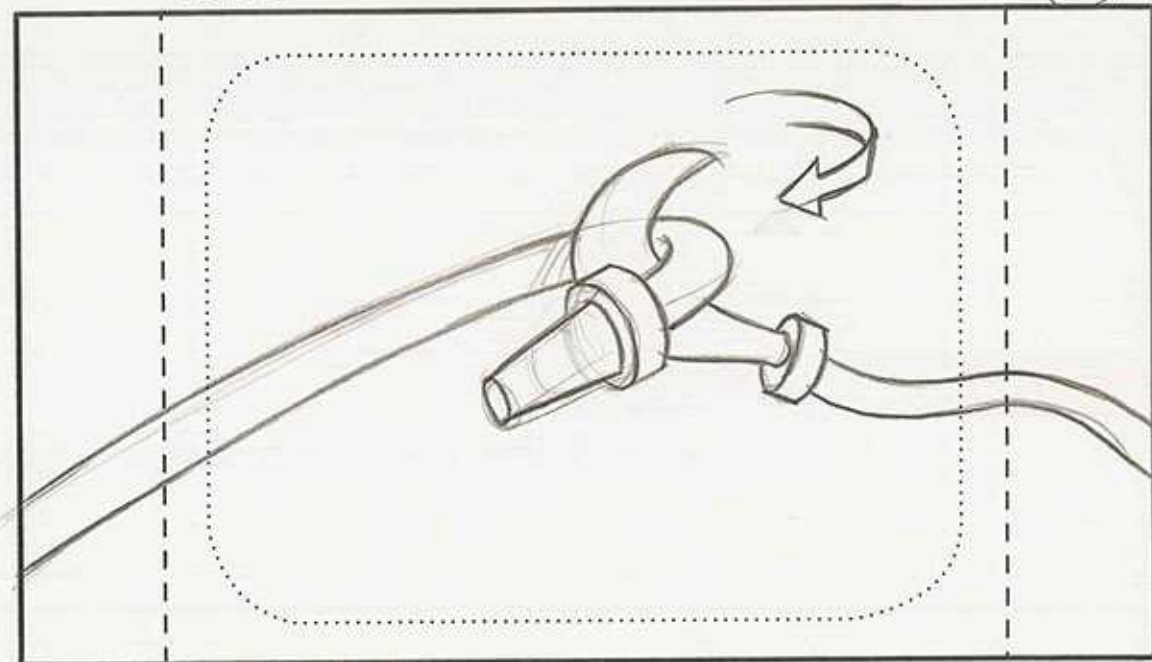

**Dialogue Action**  
... 'SNAGGING RED'S HOOK





# FIREHOUSE TALES

©2005 Warner Bros. This Material is the PROPERTY OF WARNER BROS. TELEVISION ANIMATION. It is unpublished and must not be taken from the studio, duplicated or used in any manner, except for production purposes, and may not be sold or transferred.

Sc. 79 CONTD.

Panel D

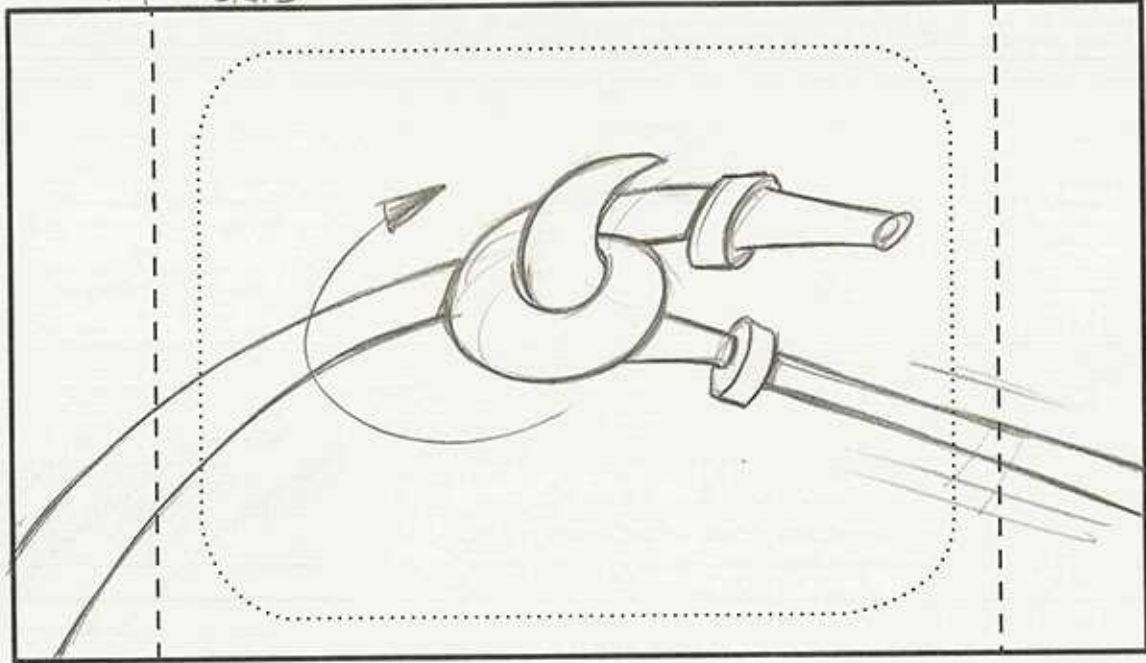

Dialogue Action

THE HOSE LOOPS AROUND THE HOOK UP.

Sc.

Panel

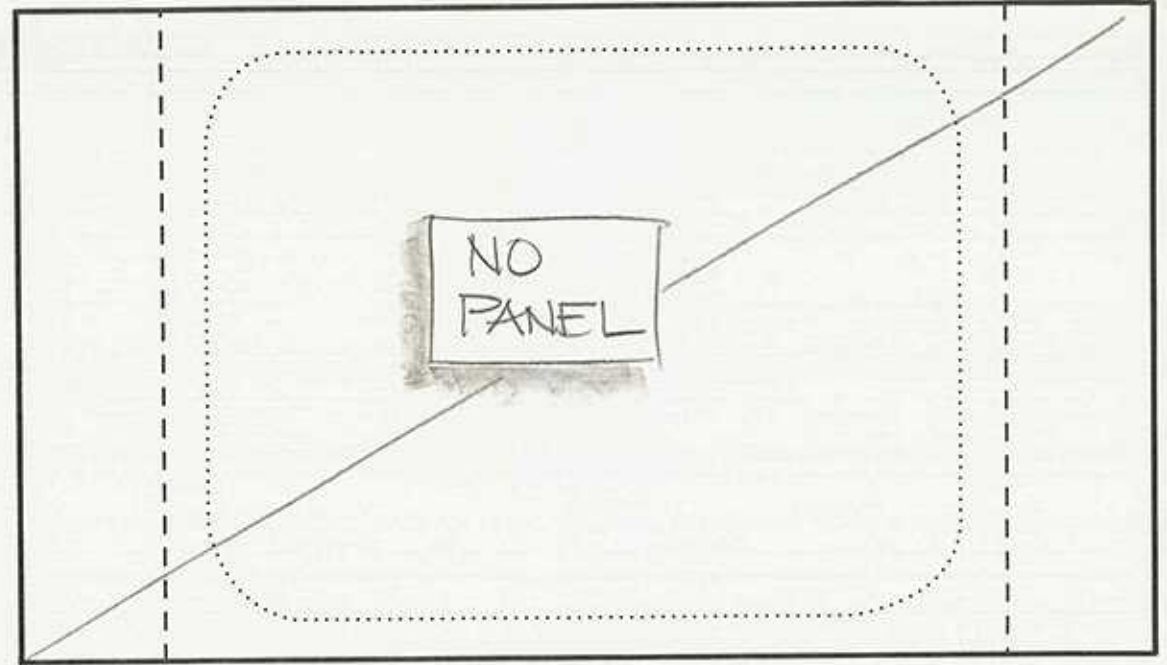

Dialogue Action

SCENE CONT'D ON NEXT PAGE.





# FIREHOUSE TALES

©2005 Warner Bros. This Material is the PROPERTY OF WARNER BROS. TELEVISION ANIMATION. It is unpublished and must not be taken from the studio, duplicated or used in any manner, except for production purposes, and may not be sold or transferred.

Sc. 79 CONTD.

Panel (D)

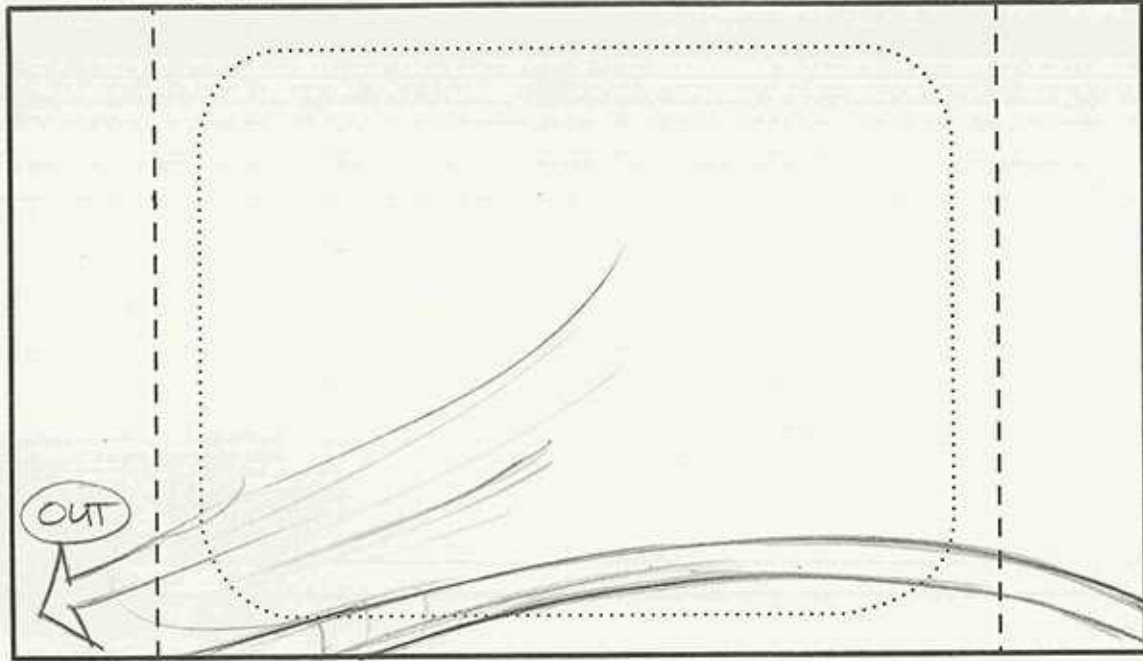

Dialogue Action

.. AND PULLS IT OUT

CUT

Sc. 80

SA 75 Panel (A)

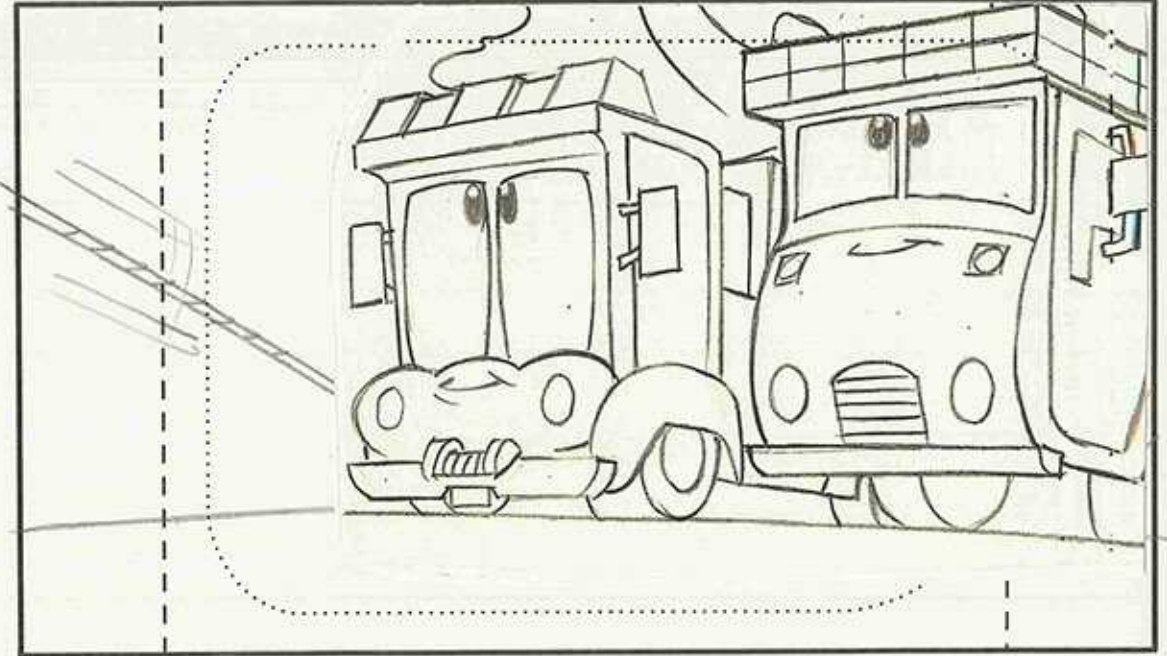

Dialogue Action

ANGLE ON RED & PETRA

(56) TANK: (OS) (CALLING OUT)  
NICE THROW! I'M READY FOR YOU





# FIREHOUSE TALES

©2005 Warner Bros. This Material is the PROPERTY OF WARNER BROS. TELEVISION ANIMATION. It is unpublished and must not be taken from the studio, duplicated or used in any manner, except for production purposes, and may not be sold or transferred.

Sc. 80 CONTD.

Panel (B)

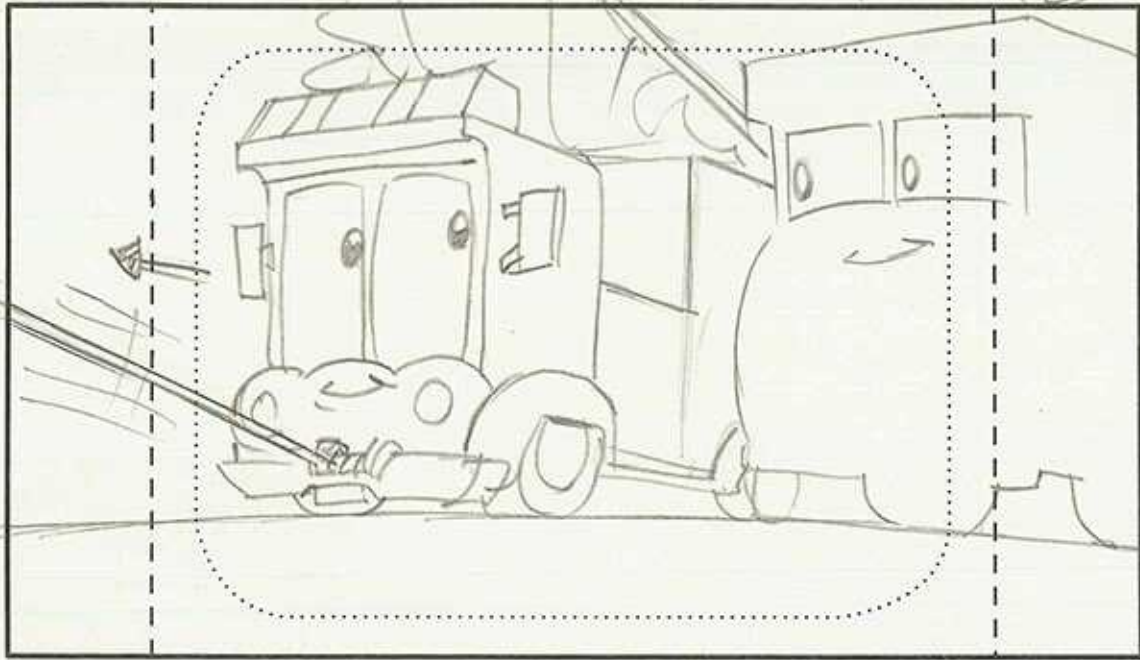

Dialogue Action

RED STARTS TO REEL IN HIS CABLE..  
HE MOVES FORWARD

Cut

Sc.

Panel

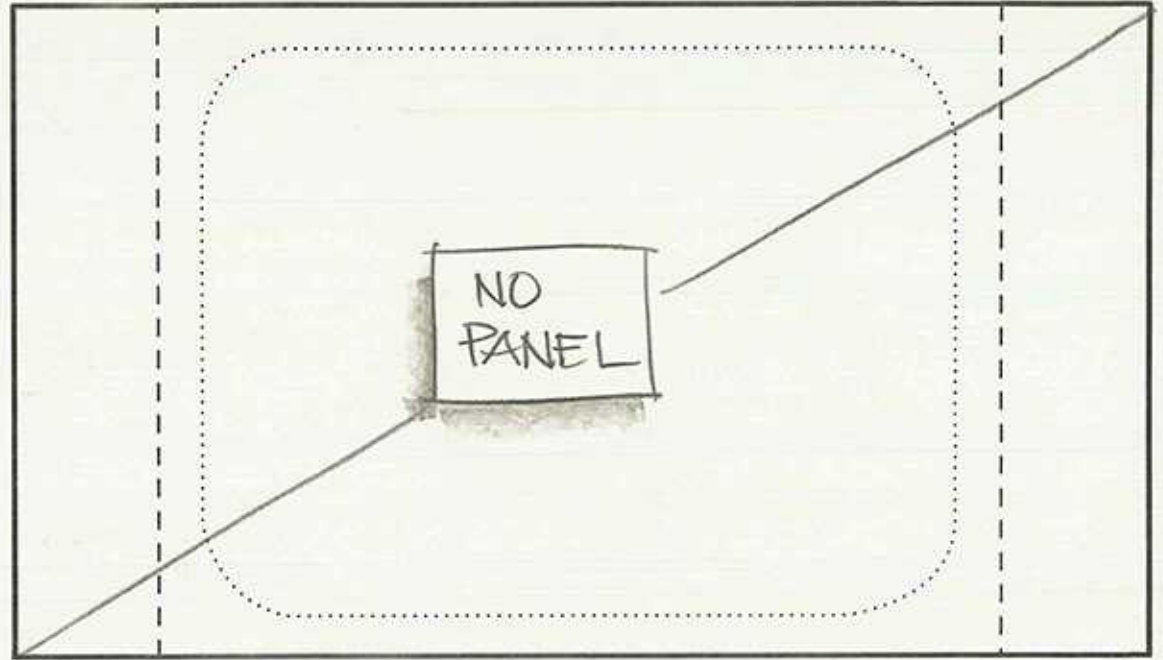

Dialogue Action





# FIREHOUSE TALES

©2005 Warner Bros. This Material is the PROPERTY OF WARNER BROS. TELEVISION ANIMATION. It is unpublished and must not be taken from the studio, duplicated or used in any manner, except for production purposes, and may not be sold or transferred.

Sc. 81

5A 77 Panel (A)

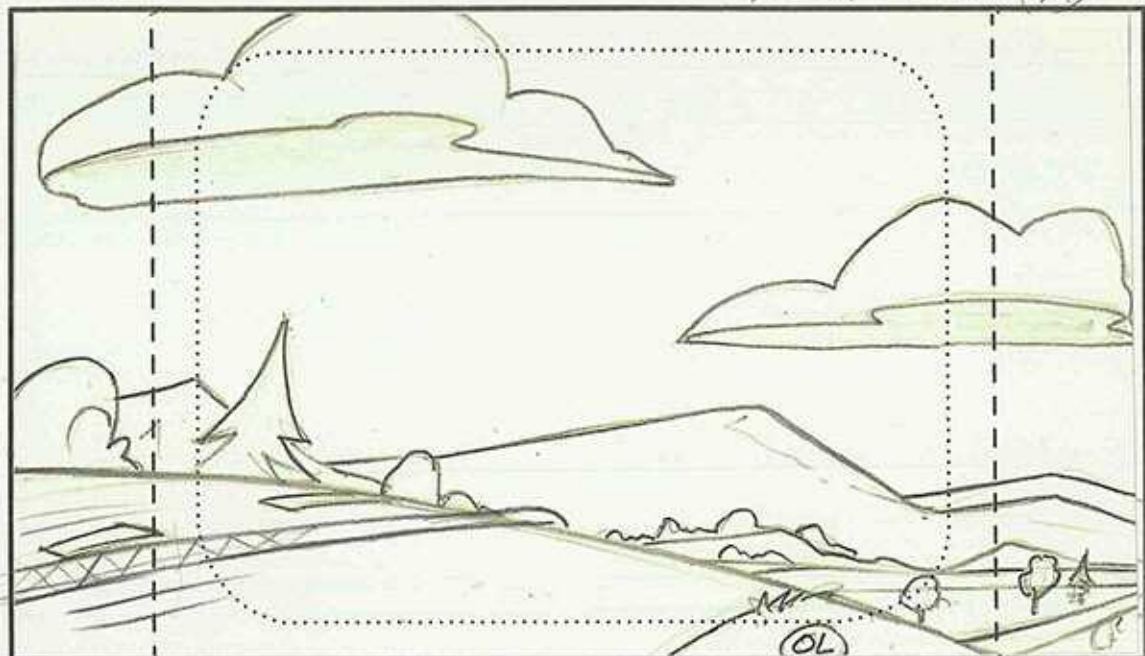

CUT ANGLE ON HILL'S CREST - THE CABLE VIBRATES.

Dialogue Action

(56A) RED: (OS)

<STRAINING>

Sc. CONTD.

Panel (A)

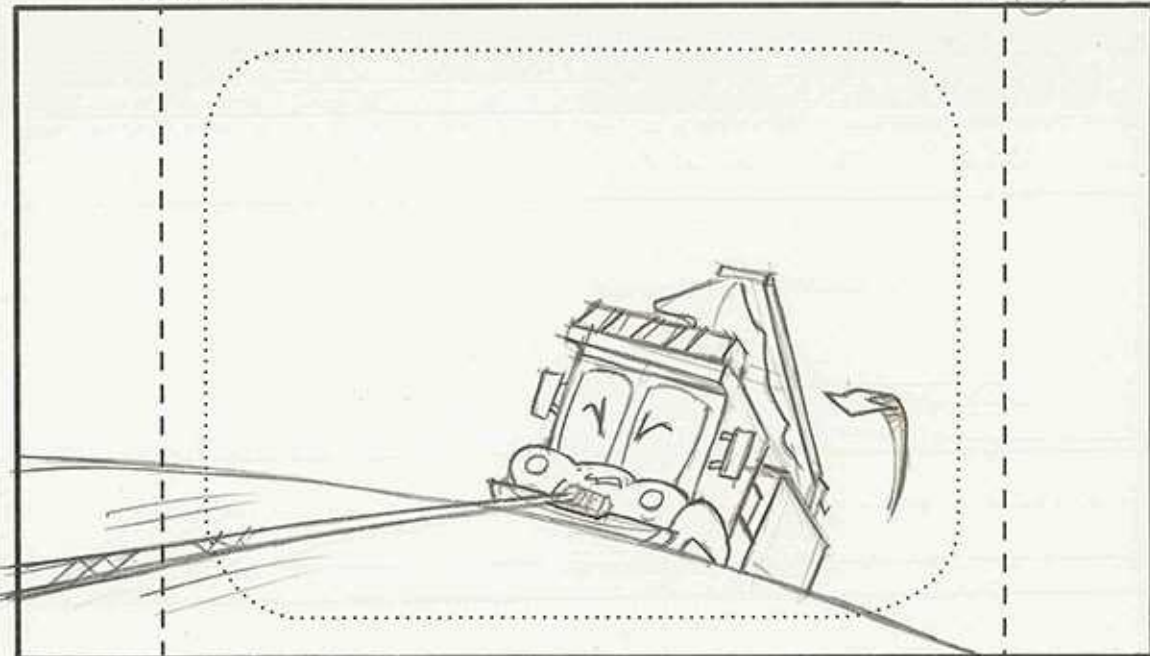

RED CRESTS THE HILL.

Dialogue Action

CUT

257-786





# FIREHOUSE TALES

©2005 Warner Bros. This Material is the PROPERTY OF WARNER BROS. TELEVISION ANIMATION. It is unpublished and must not be taken from the studio, duplicated or used in any manner, except for production purposes, and may not be sold or transferred.

Sc. 82

Panel

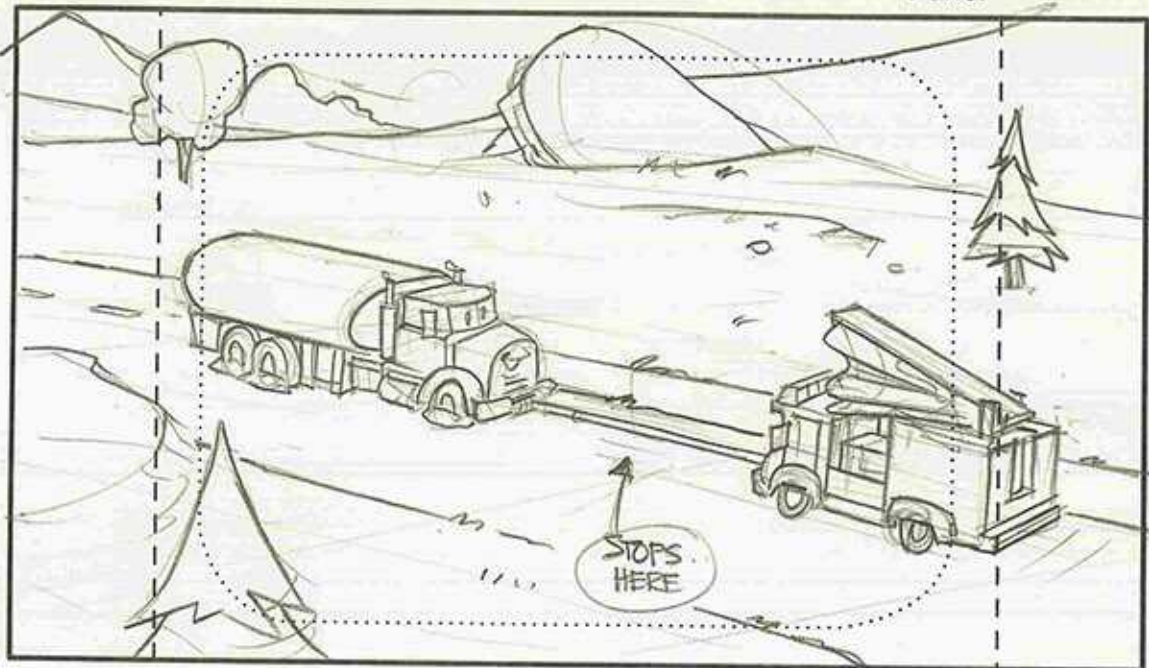

Sc. 83

Panel

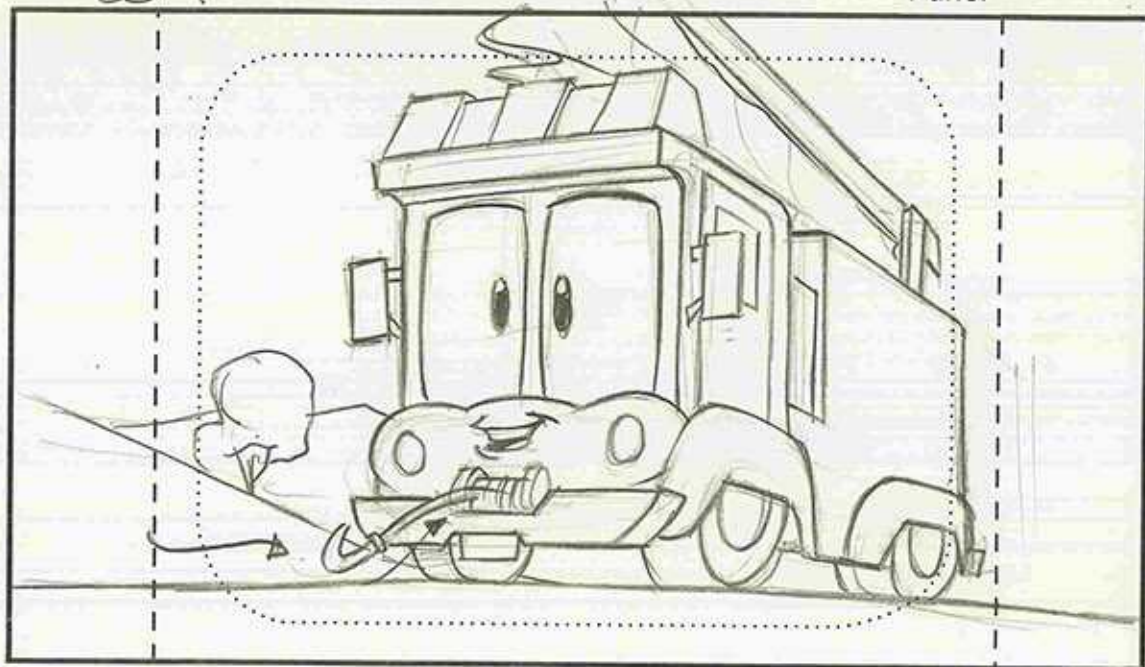

CUT WIDE ON TANK AS RED PULLS HIMSELF CLOSER.

CUT

Dialogue Action

(57) TANK:

BOY, AM I GLAD TO SEE YOU..

CLOSE ON RED. HE'S REELING IN HIS HOSE

CUT

Dialogue Action

(58) RED:

ME TOO. AS SOON AS YOU CAN GIVE ME SOME GAS, I CAN HELP GET YOUR TIRES FIXED.

257-786





# FIREHOUSE TALES

©2005 Warner Bros. This Material is the PROPERTY OF WARNER BROS. TELEVISION ANIMATION. It is unpublished and must not be taken from the studio, duplicated or used in any manner, except for production purposes, and may not be sold or transferred.

Sc. 84

SA 83 Panel

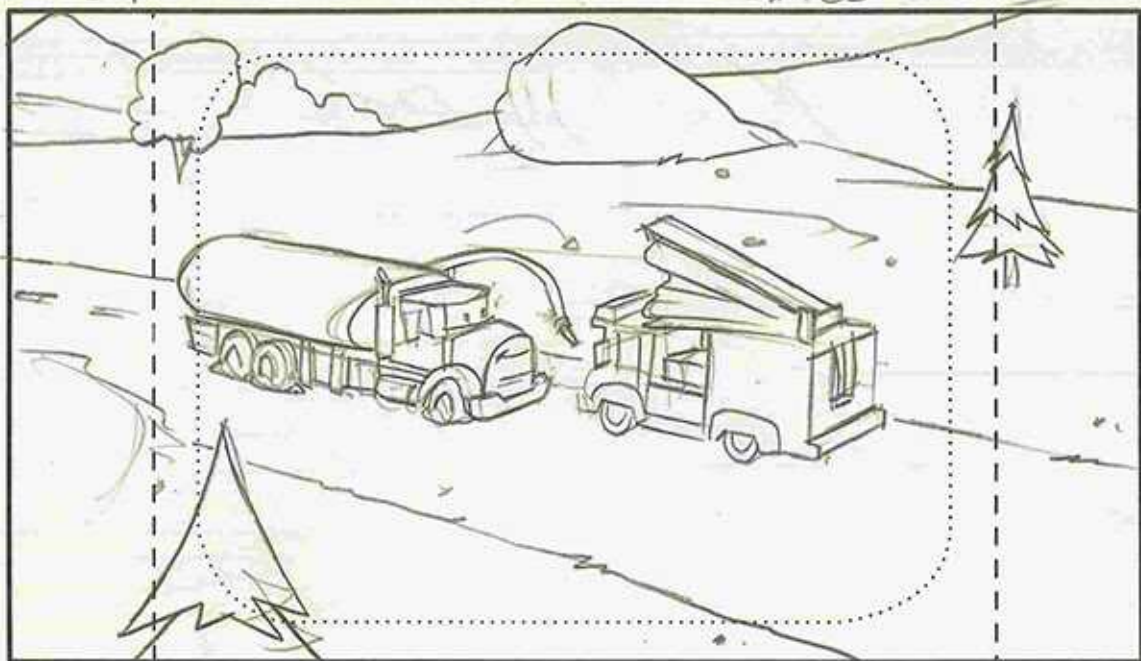

Dialogue Action

WIDE ON RED & TANK  
TANK EXTENDS HIS HOSE TOWARDS RED.



(59) WISER: (VO)

YES, IT TURNED OUT TO BE A HAPPY DAY AFTER ALL ...

Sc. 85

Panel

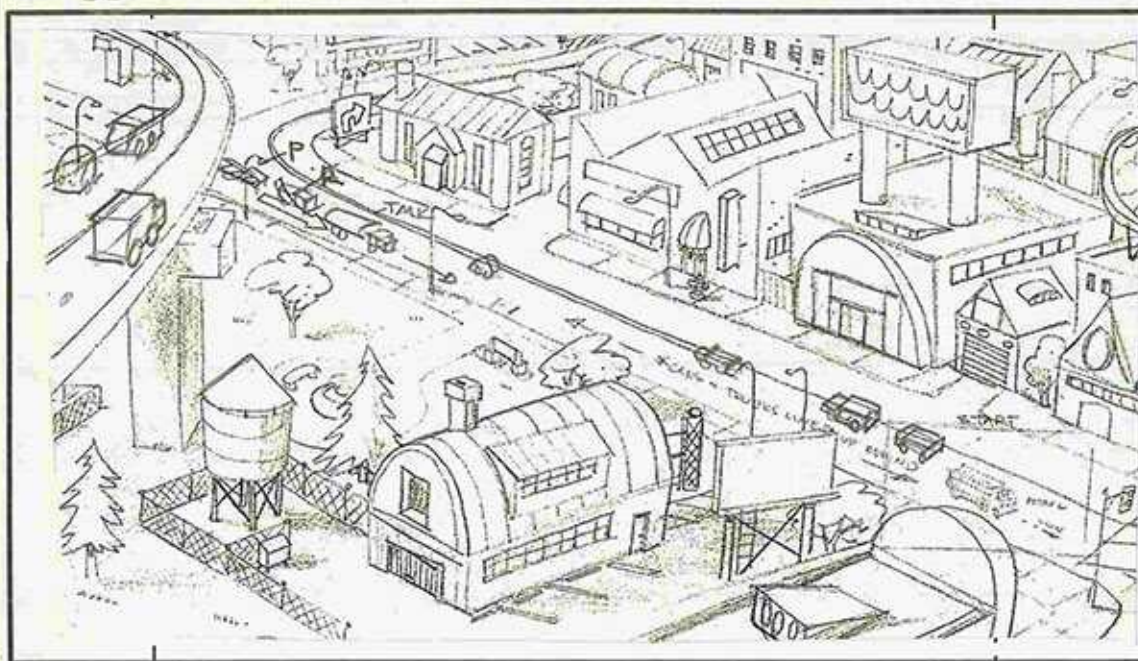

Dialogue Action

EXT DOWN SHOT STREET -DAY  
TANK, FOLLOWED BY RED PETROL & CRABBY DRIVE INTO TOWN.

(60) WISER: (VO) (CONTD)

'CAUSE ONCE TANK ROLLED INTO TOWN,

CUT





# FIREHOUSE TALES

©2005 Warner Bros. This Material is the PROPERTY OF WARNER BROS. TELEVISION ANIMATION. It is unpublished and must not be taken from the studio, duplicated or used in any manner, except for production purposes, and may not be sold or transferred.

Sc. 86

SA 21 Panel

Sc.

Panel

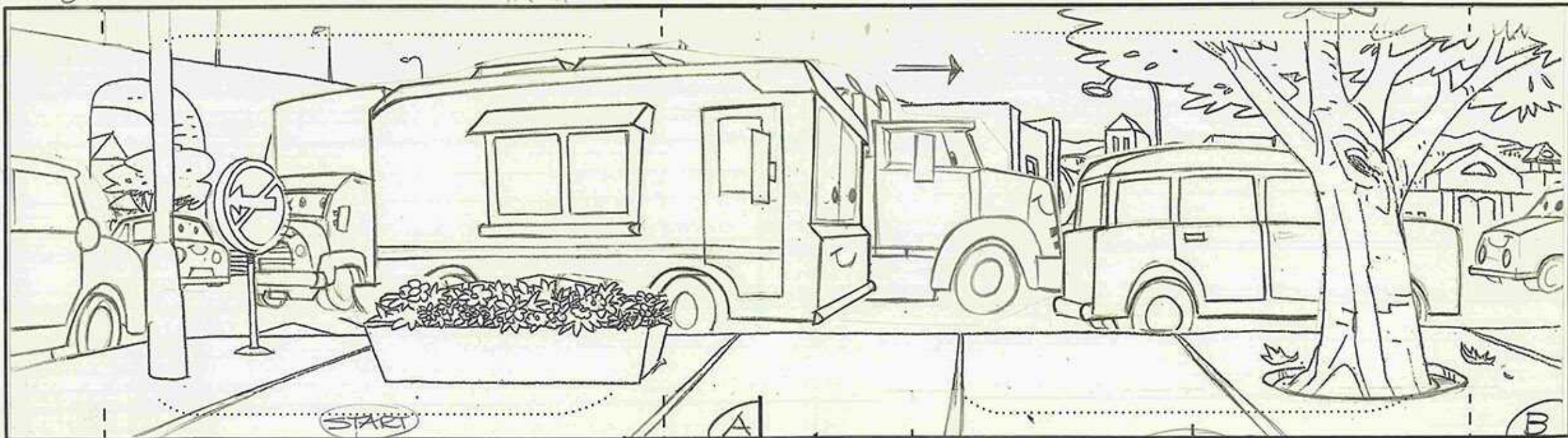

X-DISS

Dialogue Action

PAN WITH ANIM. (A) → (B)  
TANK DRIVES PAST SMILING CARS.

(60) WISER: (VO)

.. THE REST OF THE TOWN COULD GET ROLLING, TOO!

Dialogue Action

CUT

257-786





# FIREHOUSE TALES

©2005 Warner Bros. This Material is the PROPERTY OF WARNER BROS. TELEVISION ANIMATION. It is unpublished and must not be taken from the studio, duplicated or used in any manner, except for production purposes, and may not be sold or transferred.

Sc. 87

S/A 1 Panel

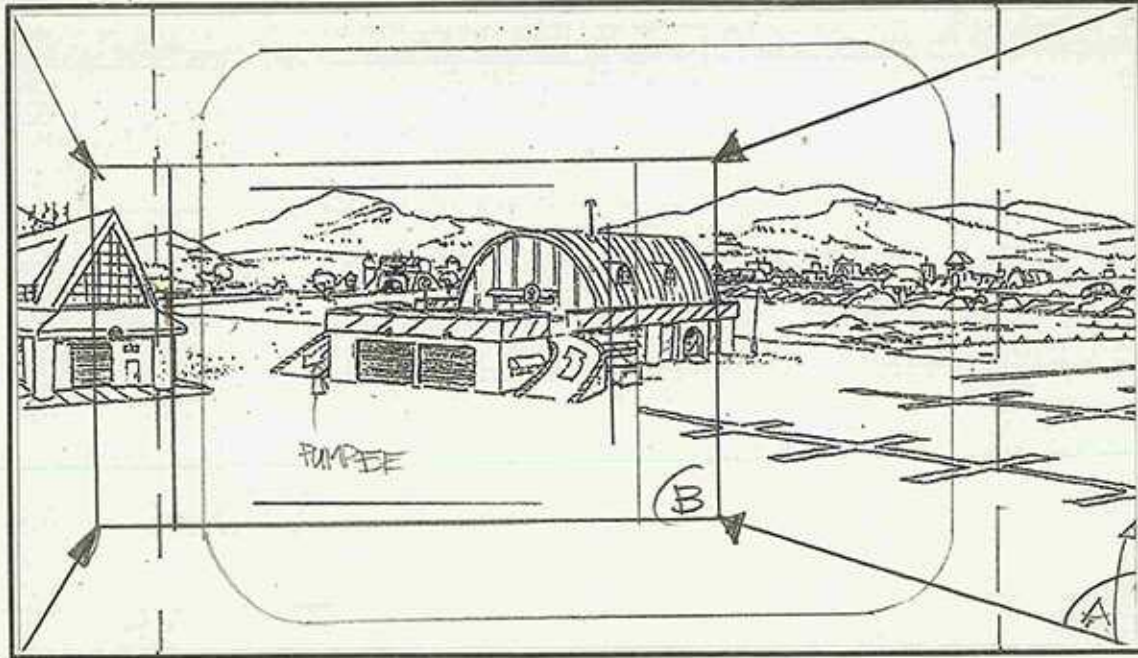

**CUT**

**Dialogue Action**

EXT. FIREHOUSE  
 PUMPEE IS STANDING BY THE GARAGE.  
 TRUCK IN (A) → (B)

Sc. 88

S/A 4 Panel (A)

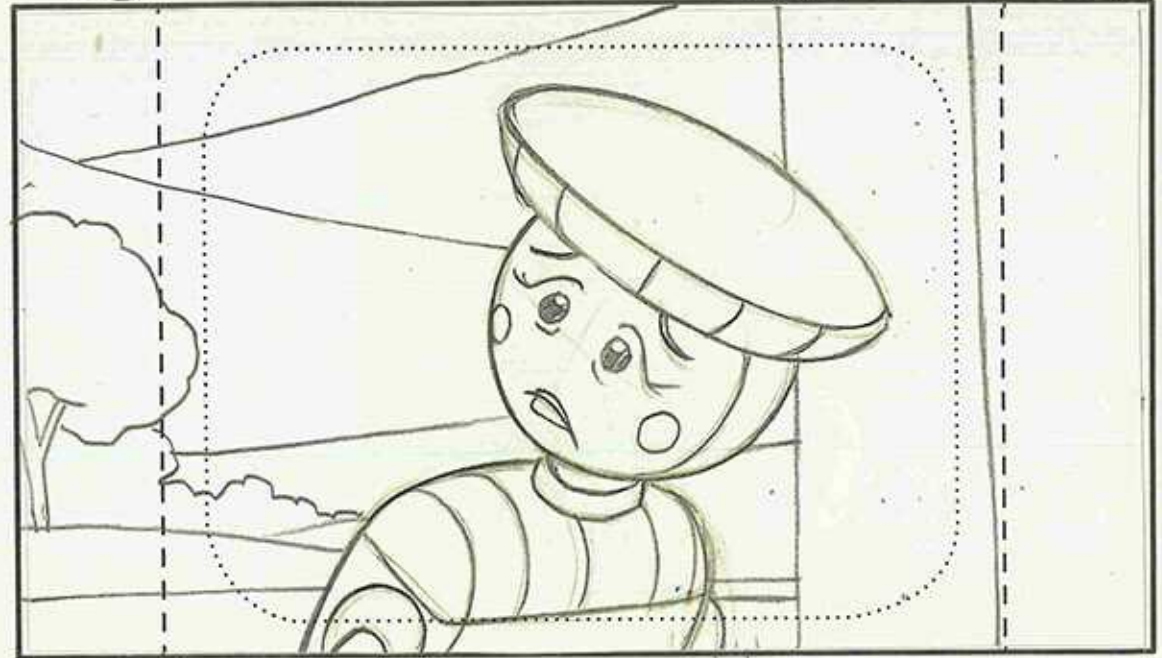

**CUT**

**Dialogue Action**

CLOSE ON PUMPEE SHE'S LOOKING AROUND.

SFX: <TANK'S HORN BLAST> (OS)





# FIREHOUSE TALES

©2005 Warner Bros. This Material is the PROPERTY OF WARNER BROS. TELEVISION ANIMATION. It is unpublished and must not be taken from the studio, duplicated or used in any manner, except for production purposes, and may not be sold or transferred.

Sc. 88 CONTD

Panel (B)

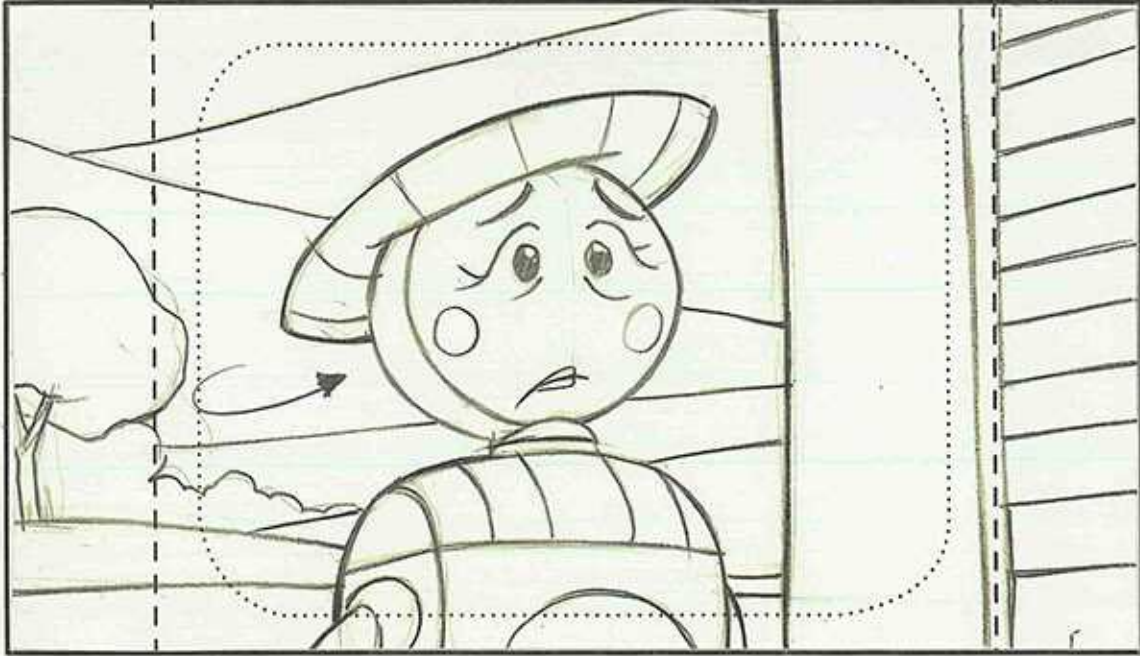

SHE LOOKS UP.

Dialogue Action

Sc. CONTD

Panel (C)

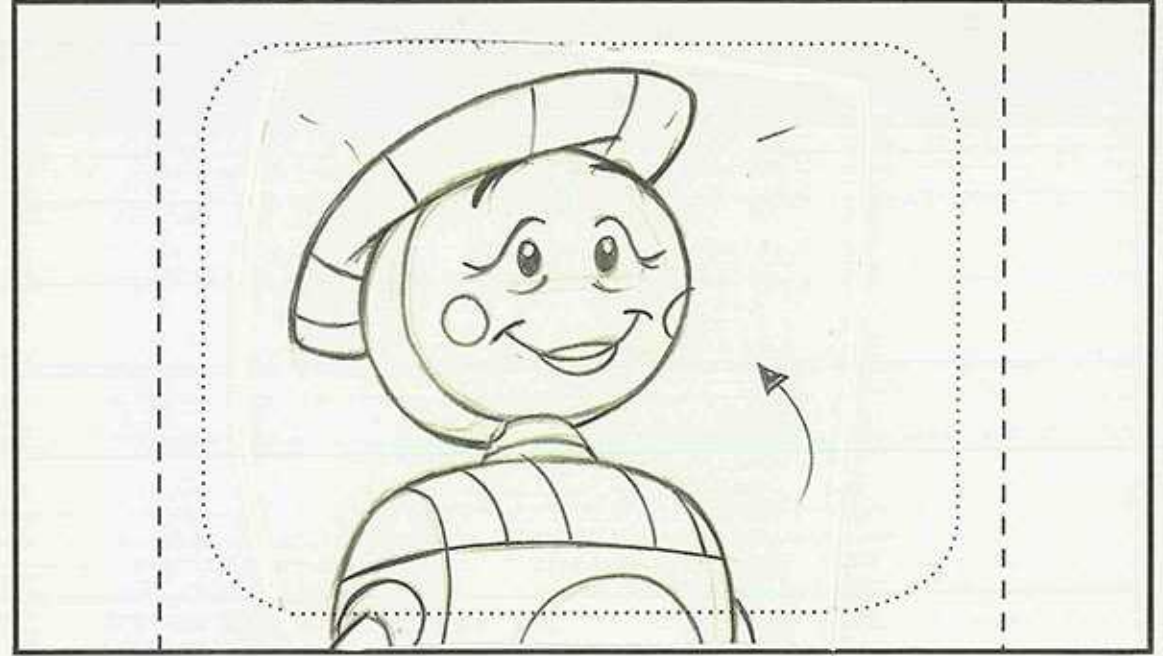

PUMPEE BRIGHTENS.

Dialogue Action

SFX: <TANK'S HORN BLAST> (OS)





# FIREHOUSE TALES

©2005 Warner Bros. This Material is the PROPERTY OF WARNER BROS. TELEVISION ANIMATION. It is unpublished and must not be taken from the studio, duplicated or used in any manner, except for production purposes, and may not be sold or transferred.

Sc. 88 CONTD

Panel D

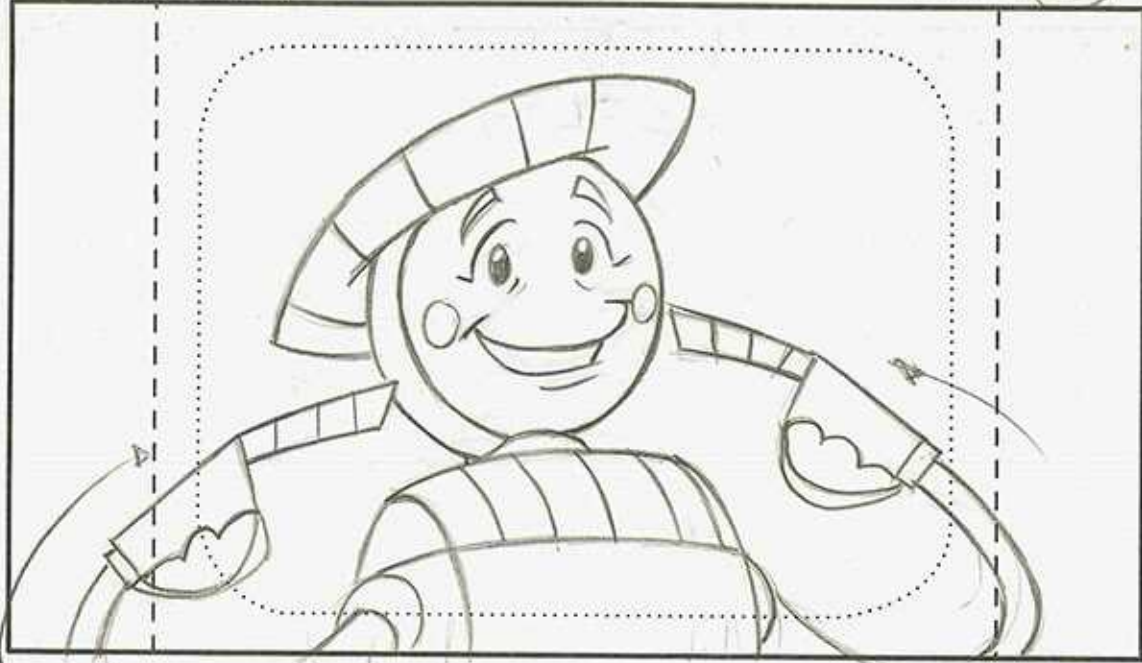

Dialogue Action

SHE BREAKS OUT IN A BIG SMILE

CUT

(61) WISER : (VO)

AND NO ONE WAS HAPPIER ABOUT IT THAN PUMPEE.

Sc. 89

Panel A

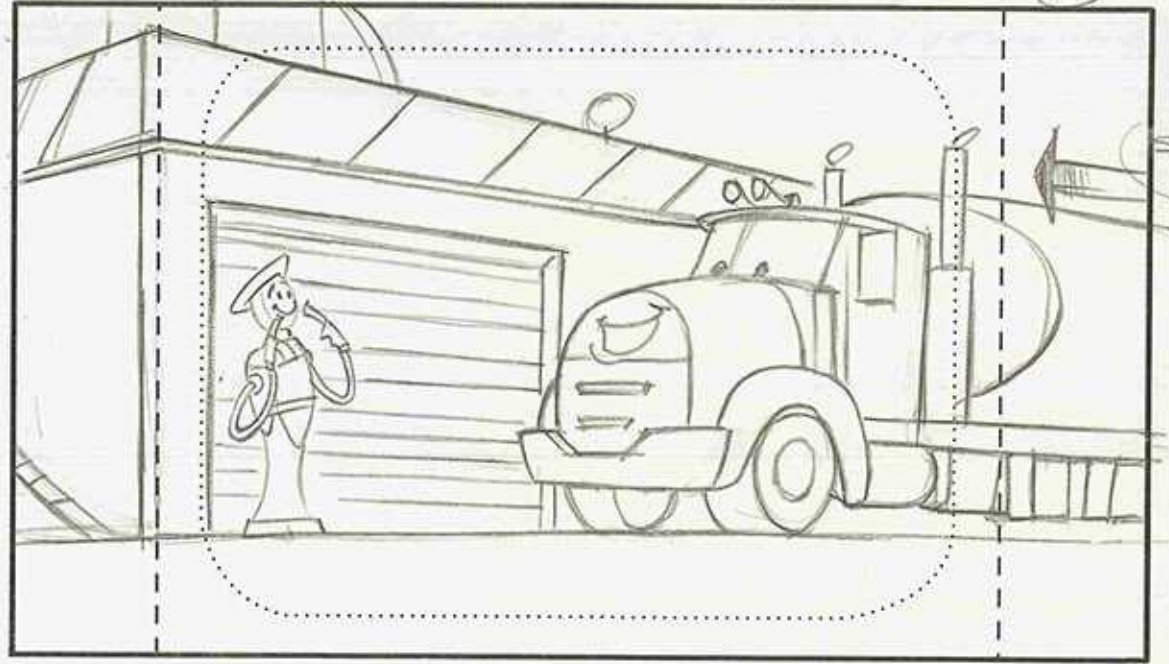

Dialogue Action

WIDER ON PUMPEE. TANK SETTLES INTO SCENE ALL SMILES.

(62) WISER : (VO) (CONTD)

YES, THINGS WERE FINALLY GETTING BACK TO NORMAL.





# FIREHOUSE TALES

©2005 Warner Bros. This Material is the PROPERTY OF WARNER BROS. TELEVISION ANIMATION. It is unpublished and must not be taken from the studio, duplicated or used in any manner, except for production purposes, and may not be sold or transferred.

Page 90:

Sc. 90.

Panel (A)

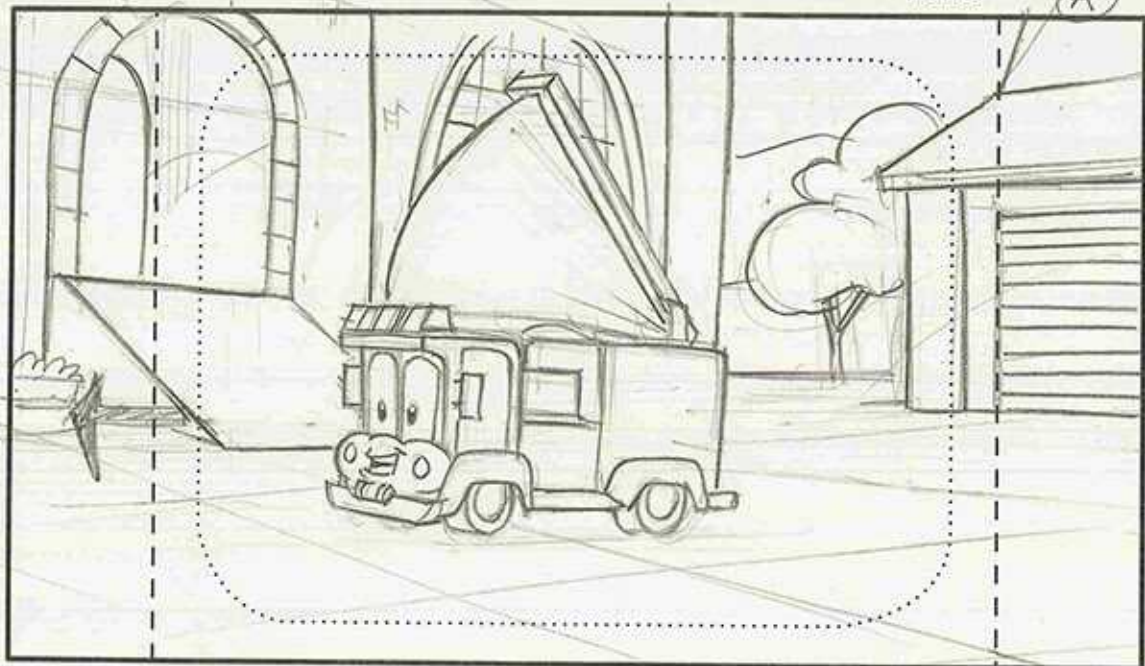

Sc. CONTD.

Panel B

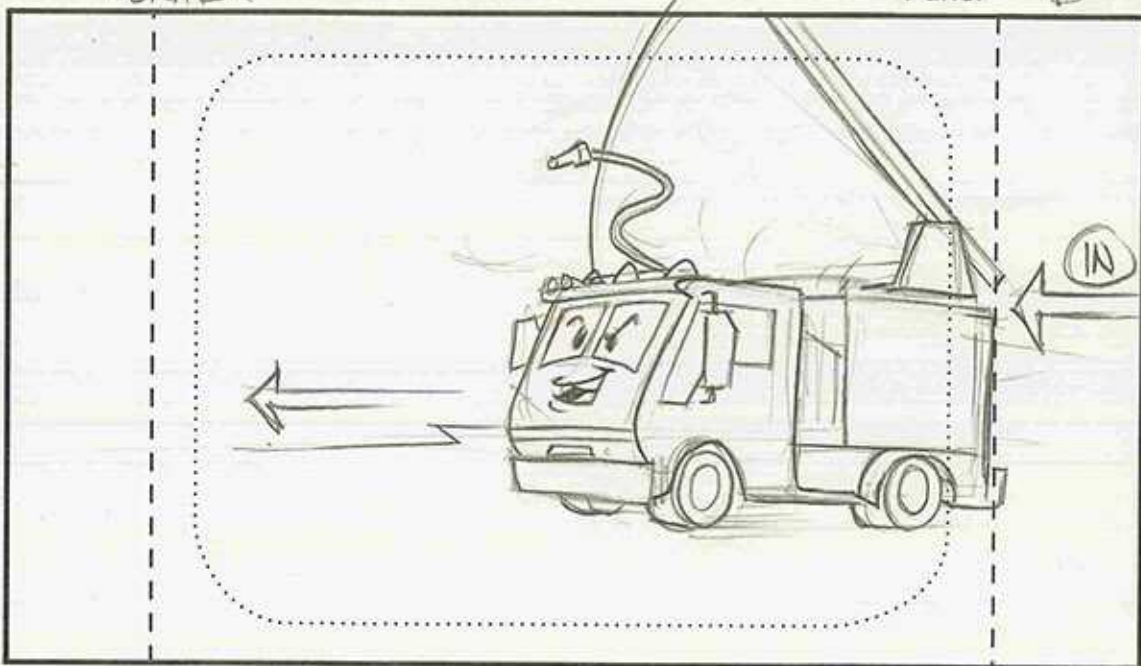

CUT

Dialogue Action

WIDER ON RED AS HE SAILS THRU SCENE

△ RED:

<LAUGHING>

Dialogue Action

FOLLOWED BY CRABBY WHO CHASE AFTER RED, BRANDISHING HIS HOSE.

⑥4 CRABBY:

GANG WAY!

257-786





# FIREHOUSE TALES

©2005 Warner Bros. This Material is the PROPERTY OF WARNER BROS. TELEVISION ANIMATION. It is unpublished and must not be taken from the studio, duplicated or used in any manner, except for production purposes, and may not be sold or transferred.

Page 90:

Sc. 90

Panel

(A)

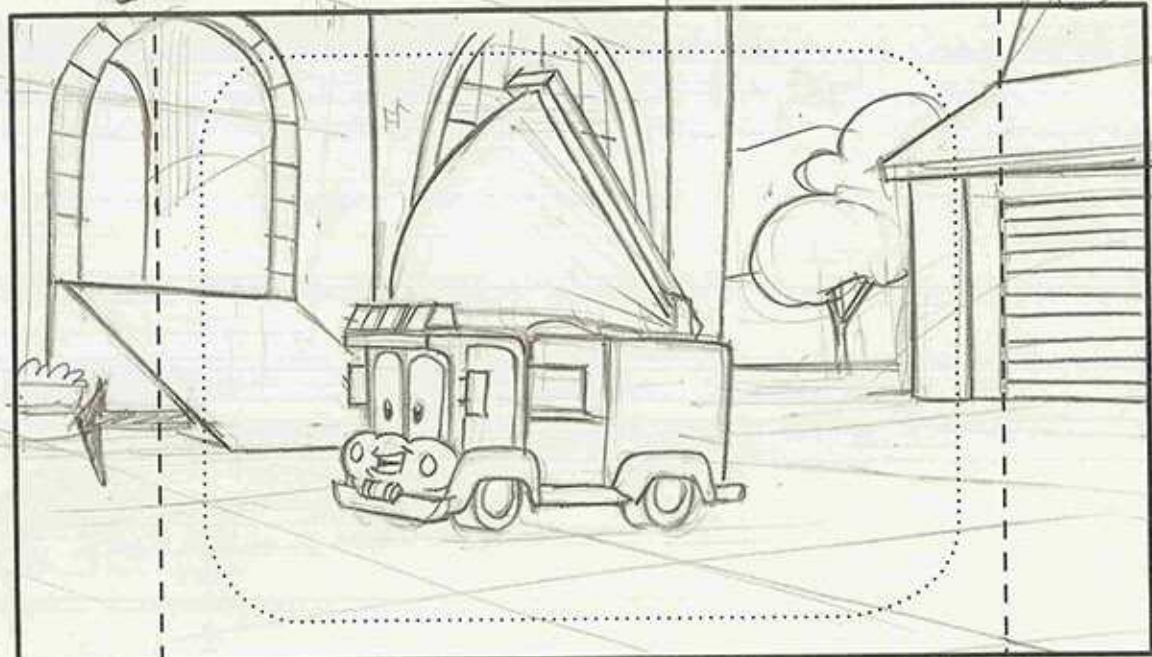

Sc. CONTD.

Panel

(B)

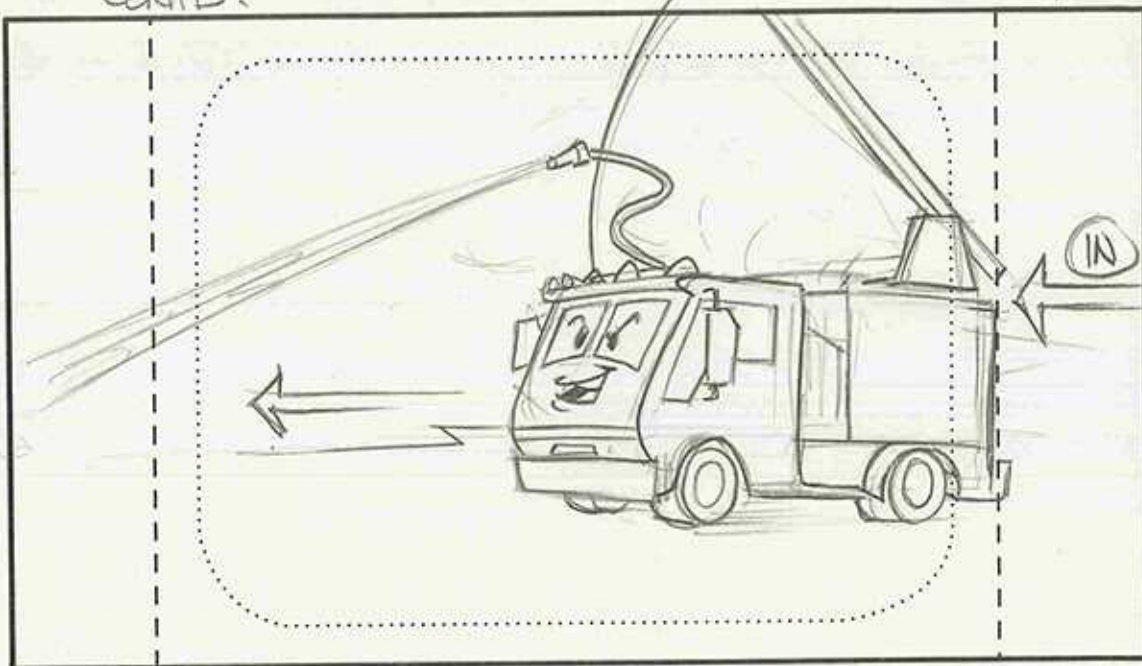

**Dialogue Action** WIDER ON RED AS HE SAILS THRU SCENE

**Dialogue Action** FOLLOWED BY CRABBY WHO CHASE AFTER RED, BRANDISHING HIS HOSE, SPRAYING AWAY.

(A) RED:  
<LAUGHING>

(B) CRABBY:  
GANG WAY!

FX: (S/T SPRAY)

257-786





# FIREHOUSE TALES

©2005 Warner Bros. This Material is the PROPERTY OF WARNER BROS. TELEVISION ANIMATION. It is unpublished and must not be taken from the studio, duplicated or used in any manner, except for production purposes, and may not be sold or transferred.

Sc. 91 CONTD

Panel C

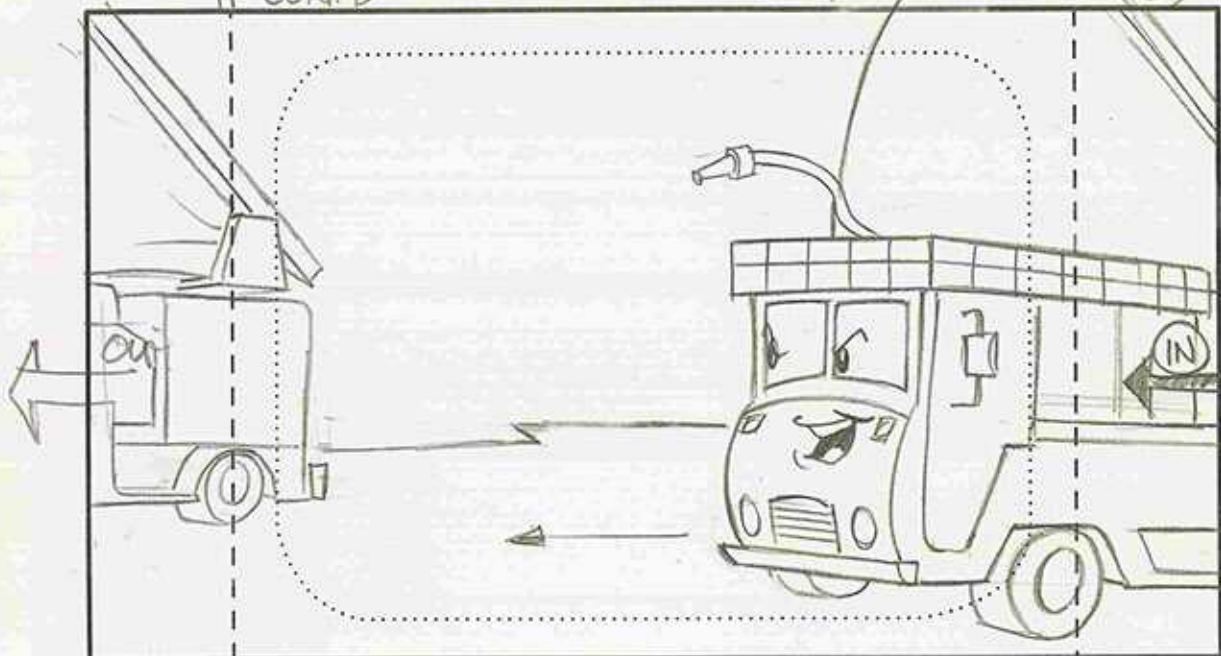

Dialogue Action

PETROL IS RIGHT ON CRABBY'S HEEL

CUT

(65) PETROL:

LOOK OUT, YE SALTY SEA DOGS!

Sc. 92

Panel

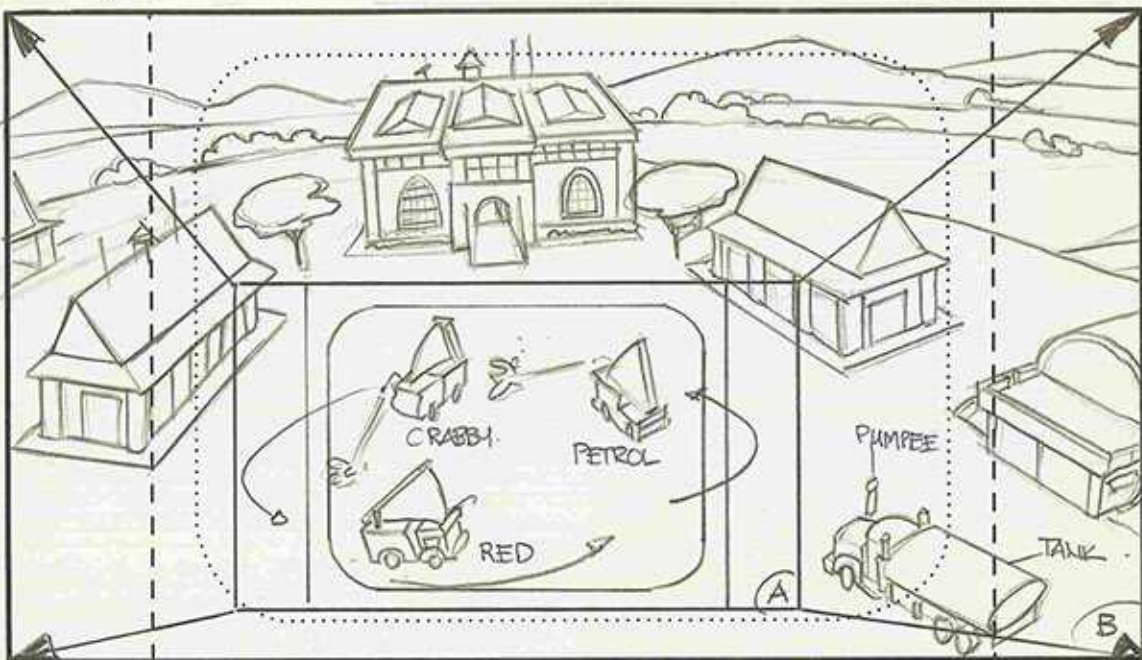

Dialogue Action

WIDE ON FIREHOUSE. THE TRUCKS CHASE EACH OTHER WHILE TANK & PUMPEE WATCH. THE TRUCKS SPRAY EACH OTHER TRUCK OUT (A) → (B) FADE OUT DURING TRUCK OUT

(66) WISER: (VO)

FX: (S/T SPRAY)

WELL, ALMOST...

(66A) PUMPEE/TANK: <LAUGHS>





# FIREHOUSE TALES

©2005 Warner Bros. This Material is the PROPERTY OF WARNER BROS. TELEVISION ANIMATION. It is unpublished and must not be taken from the studio, duplicated or used in any manner, except for production purposes, and may not be sold or transferred.

Sc. 91. CONTD

Panel (B)

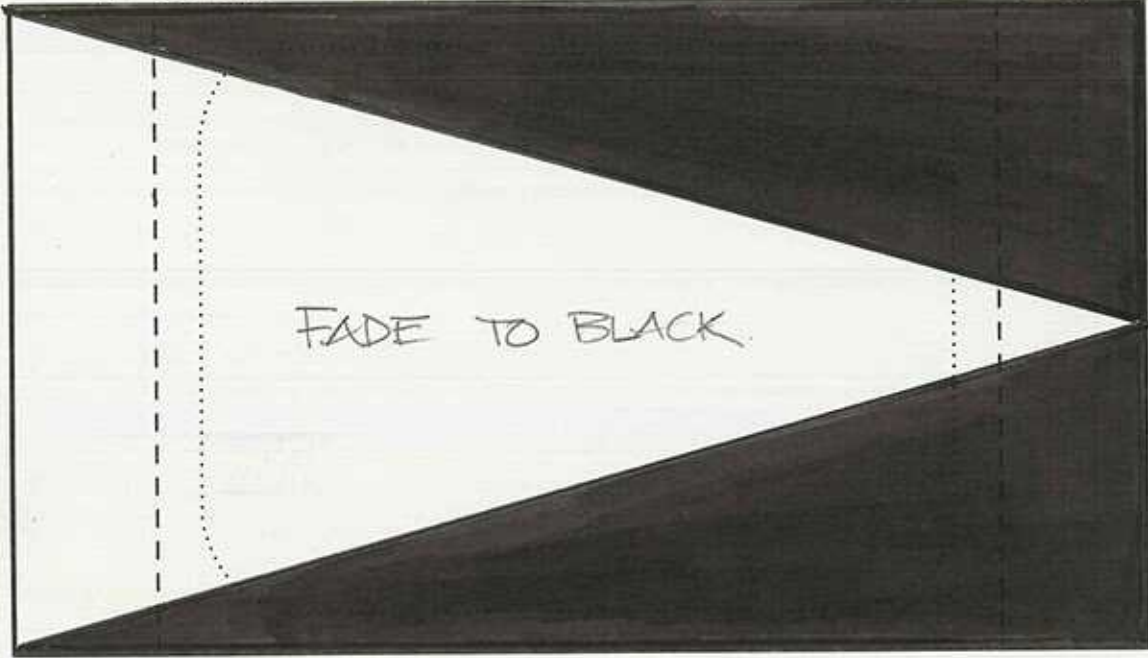

Dialogue Action

Sc.

Panel

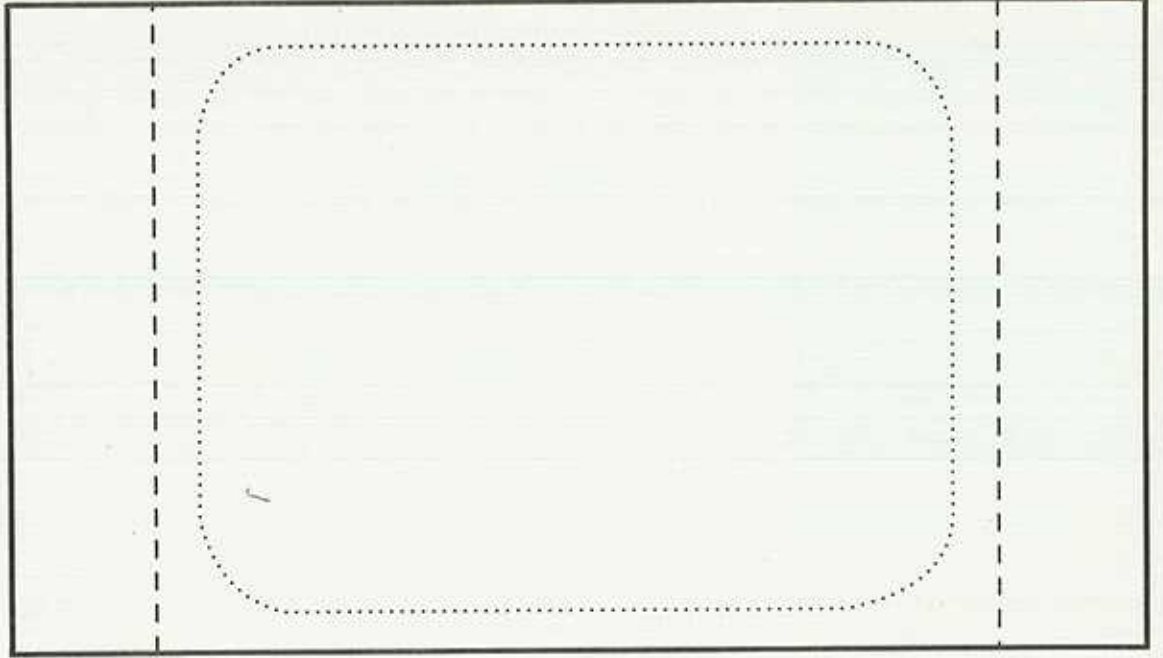

Dialogue Action