

Mastermind Career Institute

(Your Gateway To Success)



Class X Physics

I.I.T.Foundation, N.T.S.E. & Olympiad
Study Package

**Address : Mastermind Career Institute
Opposite Motherland School, Makhan Colony,
Saharanpur, UP-247001**

Contact : 9760352969

Email : info@mastermindcareerinstitute.com

Visit Us At : www.mastermindcareerinstitute.com

CONTENTS

S.No.	Topics	Page. No
1.	Light	1 – 43
2.	Electricity	44 - 68
3.	Magnetism and EMI	69 - 89
4.	Sources of Energy, Nuclear Fission & Fusion	90 – 111

LIGHT

1.1 LIGHT :

Light is a form of electromagnetic energy that causes the sensation of vision.

Optics :

It is the branch of physics which deals with the study of light. It is mainly divided into three parts :

- (i) **Geometrical optical or ray options:** It deals with the reflection or refraction.
- (ii) **Wave or physical optics:** It is concerned with nature of light and deals with interference diffraction and polarisation.
- (iii) **Quantum optics :** It deals with the interaction of light with the atomic entities of matter such as photo electric effect, Atomic excitation etc.

1.1 (a) Nature of Light :

Theories about nature of light :

- (i) **Particle nature of light (Newton's corpuscular theory):** According to Newton light travels in space with a great speed as a stream of very small particles called corpuscles. This theory was failed to explain interference of light and diffraction of light. So wave theory of light was discovered.
- (ii) **Wave nature of light :** light waves are electromagnetic waves so there is no need of medium for the propagation of these waves. They can travel in vacuum also. The speed of these waves in air or in vacuum in maximum i.e., 3×10^8 m/s
- (iii) **Quantum theory of light :** When light falls on the surface of metals like caesium, potassium etc, electrons are given out. These electrons are called 'photo-electrons' and phenomenon is called 'photo-electric effect.'
This was explained by Einstein. According to Planck light consisted of packets or quantas of energy called photons. The rest mass of photon is zero. Each quanta carries energy $E = h\nu$.
 h → Planck's constant = 6.6×10^{-34} J-s.
 ν → frequency of light

$$\text{Einstein's photo-electric equation } h(\nu - \nu_0) = \frac{1}{2} m v_{\max}^2 .$$

$h\nu_0$ = amount of energy spent in ejecting and electron out of metal surface.

V_{\max} = maximum velocity of the ejected electron.

Some phenomenon's like interference of light, diffraction of light are explained with the help of wave theory but wave theory was failed to explain the photo electric effect of light. It was explained with the help of quantum theory. So, light has dual nature.

- (i) Wave nature (ii) Particle nature

1.1 (b) Source of Light :

A body which emits light in all directions is said to be the source of light. The source can be point one or an extended one. The sources of light ware of two types :

- (i) **Luminous source** : Any object which by itself emits light is called as a luminous source. Eg. Sun and stars (natural Luminous sources), electric lamps, candles and lanterns (artificial luminous sources).
- (ii) **Non-luminous source** : Those objects which do not emit light but become visible only when light from luminous objects falls on them. They are called non-luminous. Eg. Moon, planets (natural non-luminous sources), wood, table (artificial non-luminous sources).

10.1 (c) Medium of Light :

Substance through which light propagates or tends to propagate is called medium of light.

- (i) **Transparent object** : Bodies that allow light to pass through them i.e. transmit light through them, are called transparent bodies. Eg. Glass, water, air etc.
- (ii) **Translucent object** : Bodies that can transmit only a part of light through them are called translucent objects. Eg. Froasted or ground glass, greased paper, paraffin wax.
- (iii) **Opaque object** : Bodies that do not allow light to pass through them at all are said to be opaque object, Eg. chair, desk etc.

1.1 (d) Rectilinear Propagation of Light :

Light travels in a strength line. In vacuum or air light travels with the velocity of 3×10^8 m/s

1.1 (e) Behaviour of Light at the Interface of Two Media :

When light traveling in one medium falls on the surface of a second medium the following three effects may occur :

- (i) A part of the incident light is turned back into the first medium. This is called reflection of light.
- (ii) A part of the incident light is transmitted into the second medium along a changed direction. This is called refraction of light.
- (iii) The remaining third part of light energy is absorbed by the second medium. This is called absorption of light.

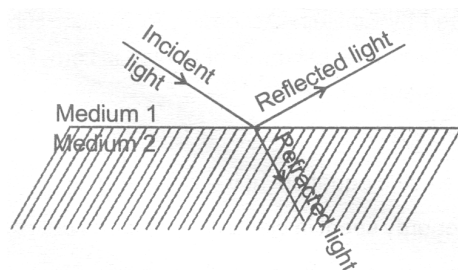

1.2 REFLECTION OF LIGHT :

When a beam of light falls on any surface, a part of it is sent back into the same medium from which it is coming. This phenomenon is known as the reflection of light.

- (i) The ray of light which falls on the mirror surface is called the incident ray. The angle of incidence is the angle made by the incident ray with the normal at the point of incidence.
- (ii) The ray of light which is sent back from the mirror is called the reflected ray. The angle of reflection is the angle made by the reflected ray with the normal at the point of incidence.
- (iii) The normal is a line at right angle to the mirror surface at the point of incidence.

1.2 (a) Laws of reflection :

- (i) Incident ray, normal ray and the reflected ray all lie on the same plane.
- (ii) The angle of incidence is always equal to the angle of reflection.

Q. What happens when a ray of light falls normally (or perpendicularly) on the surface of a mirror ?

Ans. A ray of light which is incident normally on a mirror, is reflected back along the same path because the angle of incidence as well as angle of reflection for such a ray of light are zero.

1.2 (b) Type of reflection :

- (i) **Regular reflection** : When a parallel beam of light is incident on a plane highly polished surface, the reflected beam will also be parallel and hence the whole light falling on the surface is reflected in a definite direction. Such a reflection is called regular reflection.



Such a surface is called a reflector, like a plane mirror, a polished metal surface.

- (ii) **Irregular reflection** : When a parallel beam of light is incident on a rough surface or irregular surface, the rays get reflected in all directions and the reflected light spreads over a wide area.

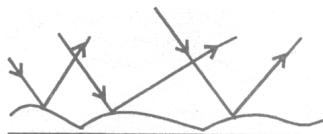

1.3 MIRROR :

It is a highly polished surface, which is quite smooth and capable of **reflecting** a good fraction of light from its surface.

1.3 (a) Object :

Anything which gives out light rays (either its own or reflected) is called an object.

- (i) **Real object** : All physical objects and light sources are real which either scatter light rays or produce light rays.

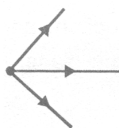

- (ii) **Virtual object** : When converging incident rays incident on eye or an optical device, there is no signal point from which light rays appear to be coming. In this case we say object is virtual.

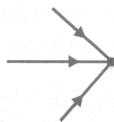

1.3 (b) Image :

The reproduction of object formed by mirror or lens is called an image.

- (i) **Real image** : An image which is formed by actual convergence of the rays of light is called real image.
- (ii) **Virtual image** : An image which only appears to the eye to be formed by the rays of light is called virtual image. It cannot be obtained on a screen.

1.3 (c) Types of mirror :

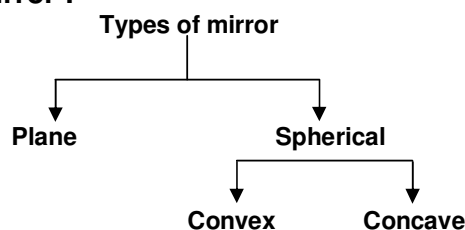

1.4 SPHERICAL MIRRORS :

A mirror whose reflecting surface is a part of a hollow of glass is known as spherical mirror. For example, a dentist uses a curved mirror to examine the teeth closely, large curved mirrors are used in telescopes at observatories. These are of the type convex and concave.

1.4 (a) Some terms related to spherical mirrors :

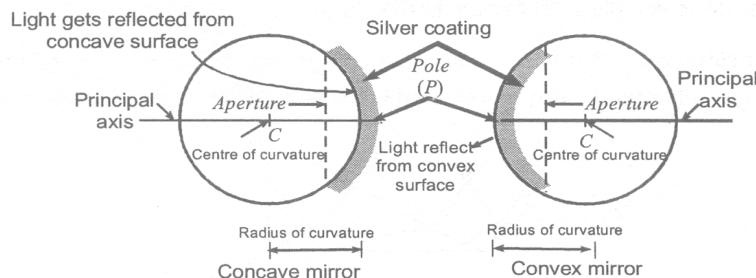

- (i) **Pole** : The central point of mirror is called it pole.
- (ii) **Centre of curvature** : The centre of the sphere of which the mirror is a part is called centre of curvature.
- (iii) **Radius of curvature** : The radius of the sphere of which the mirror is a part is called radius of curvature.
- (iv) **Principal axis** : The straight line joining the pole and the centre of curvature is called the principal axis.
- (v) **Focal plane** : A plane passing through the principal focus and a right angles to the principal axis. of a spherical mirror is called the focal plane.

- (vi) **Focal length** : The distance between the pole and the focus is called the focal length. The focal length is half the radius of curvature.
- (vii) **Aperture** : The size of the mirror is called its aperture.
- (viii) **Principal focus** :

Focus of concave mirror	Focus of convex mirror
A parallel beam of light after reflection from a concave mirror converges at a point in front of the mirror. This point (F) is the focus of a concave mirror it is real.	A parallel beam of light after reflection from a convex surface diverges and the rays do not meet. However on producing backward, the rays appear to meet at a point behind the mirror. This point is focus of the convex mirror and it is virtual.

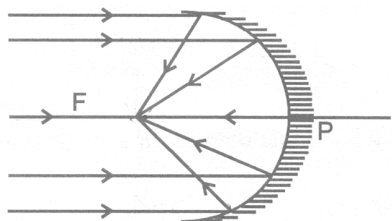

Focus of concave mirror

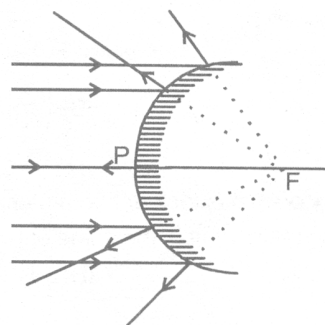

Focus of convex mirror

DAILY PRACTICE PROBLEMS # 1

OBJECTIVE DPP - 1.1

- The path along which light travels in a homogenous medium is called the :
 (A) beam of light (B) ray of light (C) pencil of light (D) none of these
- A thin layer of water is transparent but a very thick layer of water is :
 (A) translucent (B) opaque (C) most transparent (D) none of these
- Air is not visible because it _
 (A) is nearly a perfectly transparent substance
 (B) neither absorbs nor reflects light
 (C) transmits whole of light
 (D) all the above are correct
- According to laws of reflection of light :
 (A) Angle of incidence is equal to the angle of reflection
 (B) Angle of incidence is less than the angle of reflection
 (C) Angle of incidence is greater than the angle of reflection
 (D) None of these

5. Which of the following correctly represents graphical relation between angle of incidence (i) and angle of reflection (r) ?

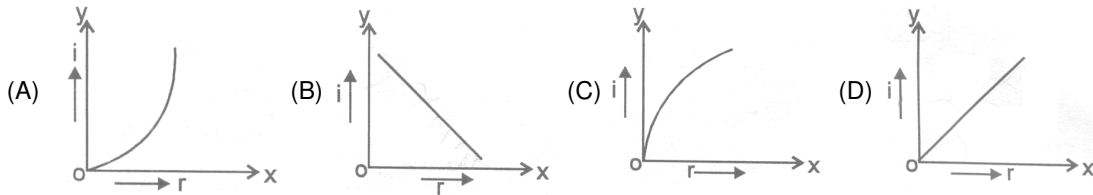

6. A convex mirror of focal length f (in air) is immersed in a liquid ($\mu = \frac{4}{3}$). The focal length of the mirror in liquid will be :

- (A) $\left(\frac{3}{4}\right) f$ (B) $\left(\frac{4}{3}\right) f$ (C) f (D) $\left(\frac{7}{3}\right) f$

7. A ray of light is incident on a plane mirror at an angle θ . If the angle between the incident and reflected rays is 80° , what is the value of θ :

- (A) 40° (B) 50° (C) 45° (D) 55°

8. When a ray of light enters a transparent medium it undergoes change is :

- (A) Frequency only (B) Wavelength only
(C) Wavelength and velocity both (D) Velocity and frequency both

SUBJECTIVE DPP - 1.2

1. According to given figure what angle does reflected rays from m_2 mirror will make with m_2 mirror ?

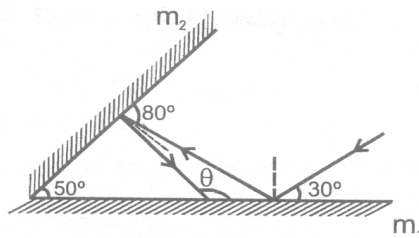

2. The mirrors are placed parallel to each other according to given figure. What will be the angle made by rays with mirror M_1 , after third reflection in degree ?

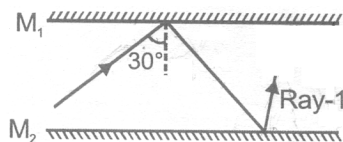

3. What are the value of angle of incidence and angle of reflection for normal incidence ?

LIGHT

2.1 CONCAVE AND CONVEX MIRROR :

Convex mirror is a spherical mirror, whose inner (cave type) surface is silvered and reflection takes place at the outer (convex) surface.

Concave mirror is a spherical mirror, whose outer bulged surface is silvered and reflection takes place from the inner hollow (cave type) surface.

2.1 (a) Rules for the formation of images by concave & convex mirrors :

- (i) A ray incident parallel to the principal axis actually passes (concave) or appears to pass (convex) through the focus.

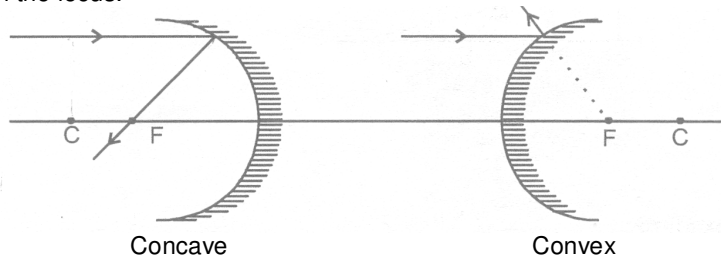

- (ii) A ray incident through the centre of curvature (C) falls normally and is reflected back along the same path.

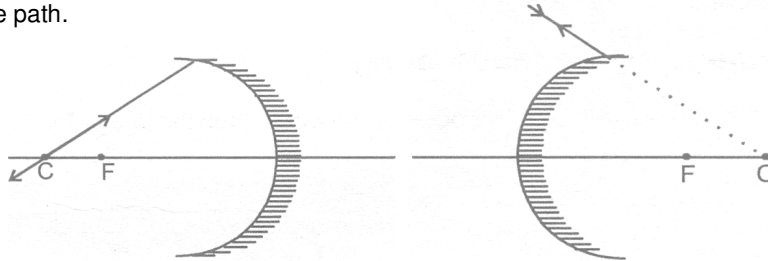

- (iii) A ray incident through the focus is reflected parallel to the principal axis.

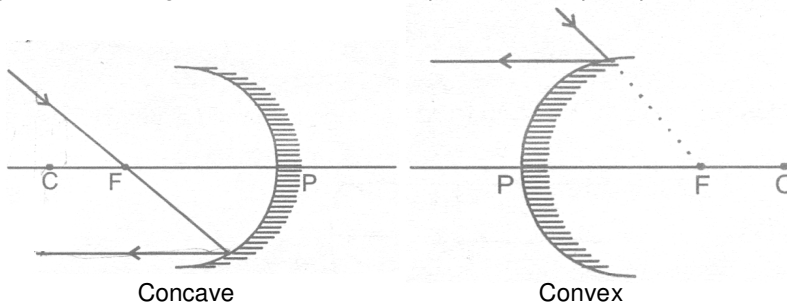

2.1 (b) Formation of image by convex mirror :

- (i) When the object is placed at infinity then image is formed at the focus. The image formed is virtual, erect and extremely demised.

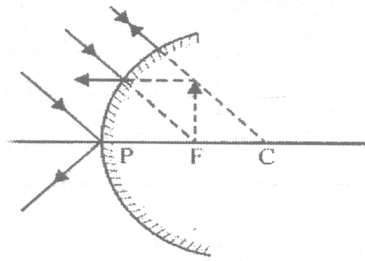

- (ii) When the object is placed between infinity and the pole then the image is formed between the focus and the pole. The image formed is virtual, erect and diminished.

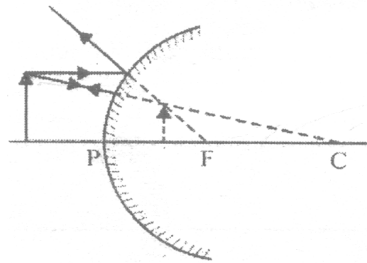

Uses of convex mirror :

Convex mirror is used as rear view mirror in automobiles like cars, trucks and buses to see the traffic at the back side.

2.1 (c) Formation of image by concave mirror

- (i) When the object is placed between the pole and the focus, then the image formed is virtual, erect and magnified.

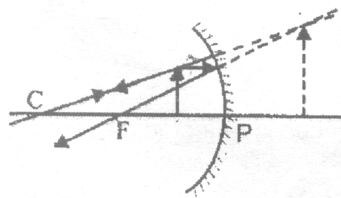

- (ii) When the object is placed at the focus then the image is formed at infinity. The image is externally magnified.

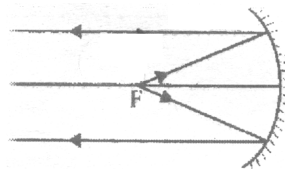

- (iii) When the object is placed between the focus and the centre of curvature then the image is formed beyond the centre of curvature. The image formed is real, inverted and bigger than the object.

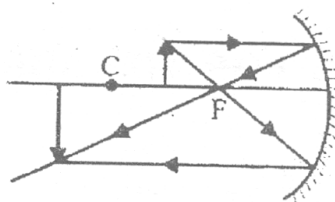

- (iv) When the object is placed at the centre of curvature, then the image is formed at the centre of curvature. The image formed is real, inverted and equal to the size of the object.

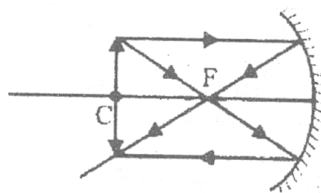

- (v) When the object is placed beyond the centre of curvature, then the image is formed between the focus and centre of curvature. The image formed is real, inverted and diminished.

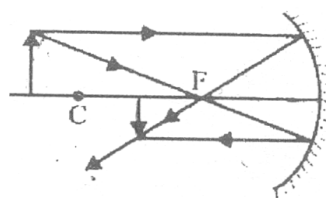

- (vi) When the object is placed at infinity then the image is formed at the focus. The image formed is real, inverted and extremely diminished in size.

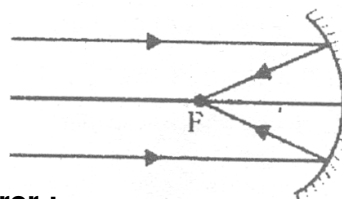

2.1 (D) Uses of concave mirror :

- (i) They are used as shaving mirrors.
- (ii) They are used as reflectors in car head-lights, search lights, torches and table lamps.
- (iii) They are used by doctors to concentrate light on body parts like ears and eyes which are to be examined.
- (iv) Large concave mirrors are used in the field of solar energy to focus sun-rays on the objects to be heated.

Q. How to distinguish between a plane mirror, a concave mirror and a convex mirror without touching them ?

Ans. We can distinguish between them by bringing our face close to each of them. All of them will produce different types of image of our face.

A plane mirror will produce an image of same size as our face. A concave mirror will produce a magnified image and our face will look much bigger. A convex mirror will produce a diminished image and our face will look small.

2.2 SIGN CONVENTION FOR MEASURING DISTANCE IN CONCAVE & CONVEX MIRROR :

- (i) All distances are measured from the pole.
- (ii) The incident ray is taken from left to right.
- (iii) Distances measured in the same direction as that of the incident ray are taken to be +ve.
- (iv) Distances measured in a direction opposite to the incident ray are taken to be -ve.
- (v) Distances measured upwards and perpendicular to principal axis are taken +ve.
- (vi) Distance measured downwards and perpendicular to principal axis are taken -ve.

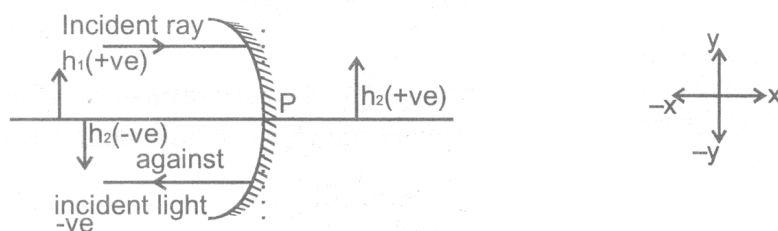

∴ $\left. \begin{array}{l} \text{Focal length concave mirror is -ve} \\ \text{Focal length of convex mirror is +ve} \end{array} \right\}$

IMPORTANT : These sign are according to the rectilinear co-ordinate system.

NOTE : Always draw a rough ray diagram while solving a numerical problem. Otherwise we will be confuse as to which distance should be taken as +ve & which -ve.

For virtual image : M is +ve [as virtual image is erect ∴ h_2 is +ve as well as h_2 is +ve]

For real image : m is -ve [as real image is always inverted ∴ m is -ve while h_1 is +ve]

2.3 MIRROR FORMULA :

The mirror formula is relation relating the object distance (u), the image distance (v) and the focal length (f) of a mirror.

The mirror formula is : $\frac{1}{u} + \frac{1}{v} = \frac{1}{f}$

2.4 POWER OF MIRROR :

A spherical mirror has infinite number of focus. Optical power of a mirror (in Dioptres) = $-\frac{1}{f(\text{in meters})}$

2.5 RELATION BETWEEN FOCAL LENGTH (f) AND RADIUS OF CURBATURE (R) :

$$R = 2f \text{ or } f = \frac{R}{2}$$

A curved or spherical mirror is reflecting surface, which is formed by a part of a hollow sphere. The spherical mirrors are of two types concave mirror and convex mirror.

2.6 MAGNIFICATION FOR CONCAVE MIRROR :

For magnification consider an object AB of height h_1 , placed beyond C, such that its one ray is incident at pole P & another passes through C. After reflection ray from pole comes in the direction PX and the one which passed through C after reflection meets PX at A'. So A'B' is the image of height h_2 .

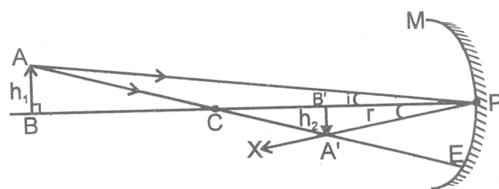

Now $\triangle ABP$ & $\triangle A'B'P$ are similar (By AAA)

$$\therefore \frac{A'B'}{AB} = \frac{B'P}{BP}$$

$$\frac{-h_2}{h_1} = \frac{-v}{-u} \Rightarrow \frac{h_2}{h_1} = -\frac{v}{u}$$

As $m = \frac{h_2}{h_1}$

$$\therefore m = -\frac{v}{u}$$

2.7 ILLUSTRATION :

(i) A 2.0 cm long object is placed perpendicular to the principal axis of a concave mirror. The distance of the object from the mirror is 30 cm and its image is formed 60 cm from the mirror on the same side of the mirror as the object. Find the height of the image formed.

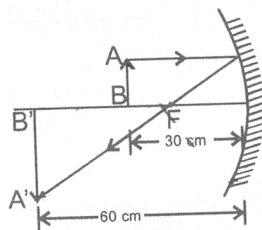

Sol. $u = -30 \text{ cm}, v = -60 \text{ cm}$

$$\therefore m = \frac{h_2}{h_1} = -\frac{v}{u} = -\frac{-60}{-30} = -2$$

$$\Rightarrow H_2 = -2h_1 = -2 \times 2 = -4 \text{ cm.}$$

\therefore Height of the image is 4 cm. It is inverted.

- (iii) A 1.2 cm long pin is placed perpendicular to the principal axis of a convex mirror of focal length 12 cm, at a distance of 8 cm from it.
- (a) Find the location of the image (b) Find the height of the image. (c) Is the image erect or inverted ?

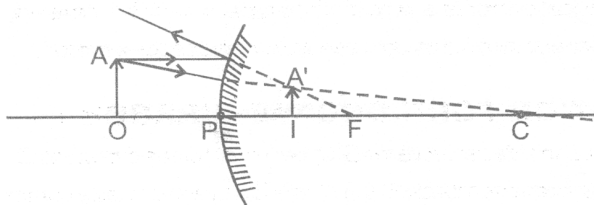

Sol. Here f is +ve so $f = 12$ cm.

Also $u = -8$ cm.

$$\therefore \frac{1}{v} + \frac{1}{u} = \frac{1}{f}$$

$$\text{Or } \frac{1}{v} = \frac{1}{f} - \frac{1}{u} = \frac{1}{12} + \frac{1}{8} = \frac{5}{24} \quad \therefore v = \frac{24}{5} \text{ cm} = 4.8 \text{ cm}$$

Given, $h_1 = 1.2$ cm

$$\text{We know } \frac{h_2}{h_1} = -\frac{v}{u} \quad \Rightarrow \quad h_2 = -\frac{v}{u} \times h_1 = 0.72 \text{ cm}$$

Image formed is erect.

DAILY PRACTICE PROBLEMS # 2

OBJECTIVE DPP-2.1

- The image of the moon is formed by a concave mirror whose radius of curvature is 4.8 m at a time when distance from the moon is 2.4×10^8 m. If the diameter of the image is 2.2 cm the diameter of the moon is -
 (A) 1.1×10^6 m (B) 2.2×10^6 m (C) 2.2×10^8 m (D) 2.2×10^{10} m
- The focal length of a concave mirror is f and the distance from the object to the principal focus is a . The magnitude of magnification obtained will be-
 (A) $(f + a)/f$ (B) f/a (C) \sqrt{f} / \sqrt{a} (D) f^2/a^2
- The magnification of an object placed 10 cm from a convex mirror of radius of curvature 20 cm will be.
 (A) 0.2 (B) 0.5 (C) 1 (D) infinity
- The image formed by a concave mirror is observed to be virtual, erect and larger than the object. the position of the object should be-
 (A) between the focus and the centre of curvature.
 (B) at the centre of curvature
 (C) beyond the centre of curvature
 (D) between the pole of the mirror and the focus

5. The magnification produces by a concave mirror-
- (A) is always more than one
 - (B) is always less than one
 - (C) is always equal to one
 - (D) may be less than or greater than one
6. Choose the correct relation between u, v and R -
- (A) $R = \frac{2uv}{u+v}$
 - (B) $R = \frac{2}{u+v}$
 - (C) $R = \frac{2(u+v)}{uv}$
 - (D) none of these
7. The image formed by a concave mirror is real, inverted and of the same size as that of the object. The position of the object should be :
- (A) Beyond C
 - (B) Between C and F
 - (C) At C
 - (D) At F
8. A boy is standing in front of a plane mirror at a distance of 3 m from it. What is the distance between the boy and his image ?
- (A) 3 m
 - (B) 4.5 m
 - (C) 6 m
 - (D) none of these

SUBJECTIVE DPP -2.2

1. An object is placed in front of a concave mirror of radius of curvature 15 cm at a distance of (a) 10 cm and (b) 5 cm. Find the position, nature and magnification of the image in each case.
2. What is the difference between virtual images produced by concave, plane and convex mirrors ?
3. A concave mirror produces three times magnified real image of an object placed at 10 cm in front of it. Where is the image located ?

LIGHT

3.1 REFRACTION OF LIGHT :

When light travels in the same homogeneous medium it travels along a straight path. However, when it passes from one transparent medium to another, the direction of its path changes at the interface of the two media. This is called refraction of light.

The phenomenon of the change in the path of the light as it passes from one transparent medium to another is called refraction of light. The path along which the light travels in the first medium is called incident ray and that in the second medium is called refracted ray. The angles which the incident ray and the refracted ray make with the normal at the surface of separation are called angle of incidence (i) and angle of refraction (r) respectively.

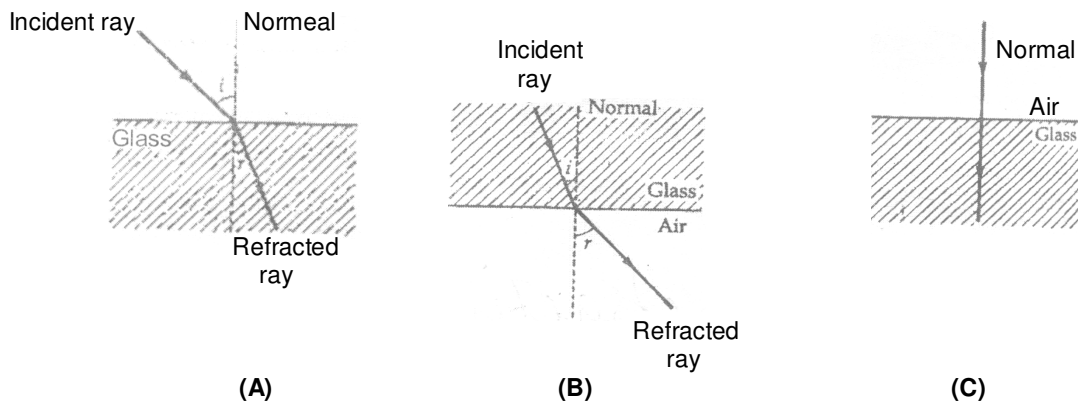

Showing different cases of refraction

It is observed that :

(i) When a ray of light passes from an optically rarer medium to a denser medium it bends towards the normal ($\angle r < \angle i$), as shown in figure (A).

(ii) When a ray of light passes from an optically denser to a rarer medium it bends away from the normal ($\angle r > \angle i$) as shown in figure (B).

(iii) A ray of light traveling along the normal passes undeflected, as shown in figure (C). Here $\angle i = \angle r = 0^\circ$.

3.1 (a) Cause of Refraction :

We come across many media like air, glass, water etc. A medium is a transparent material through which light is transmitted. Every transparent medium has a property known as optical density. The optical density of a transparent medium is closely related to the speed of light in the medium. If the optical density of a transparent medium is low, then speed of light in that medium is high. Such a medium is known as optically rarer medium. Thus, optically rarer medium is that medium through which light travels fast. In other words, a medium in which speed of light is more is known as optically rarer medium.

On the other hand, if the optical density of transparent medium is high, then the speed of light in that medium is low. Such a medium is known as optically denser medium. Thus, optically denser medium is that medium through which light travels slow. In other words, a medium in which speed of light is less is known as optically denser medium.

Speed of light in air is more than the speed of light in water, so air is optically rarer medium as compared to the water. In other words, water is optically denser medium as compared to air. Similarly, speed of light in water is more than the speed of light in glass, so water is optically rarer medium as compared to the glass. In other words, glass is optically denser medium as compared to water.

When light goes from air (optically rarer medium) to glass (optically denser medium) such that the light in air makes an angle with the normal to the interface separating air and glass, then it bends from its original direction of propagation. Similarly, if light goes from glass to air, again it bends from its original direction of propagation. The phenomena of bending of light from its path is known as refraction. We have seen that the speed of light in different media is different, so we can say that refraction of light takes place because the speed of light is different in different media. Thus, **the cause of refraction** can be summarised as follows :

NOTE :

- (i) Refraction is the deviation of light when it crosses the boundary between two different media (of different optical densities) and there is a change in both wavelength and speed of light.
- (ii) The frequency of the refracted ray remains unchanged.
- (iii) The intensity of the refracted ray is less than that of the incident ray. It is because there is partial reflection and absorption of light at the interface.

3.1 (b) Effects of refraction of Light :

- (i) If a straight stick is partially put in water, it appears to be inclined.
- (ii) If we see a water tank its bottom appears to be raised. It also appears to be concave shaped although it is flat.
- (iii) The sun is visible a few minutes earlier than it actually rises above horizon, because as we go up from earth, the density of air layer decreases, then rays from sun keep on bending towards normal till it enters the eye.

∴ Sun appears to be at S'. For the same reason it keeps on appearing two minutes after sun-set. Hence the day i.e. the time between the sunrise & sunset is four minutes longer. The day therefore gets longer 4 minutes.

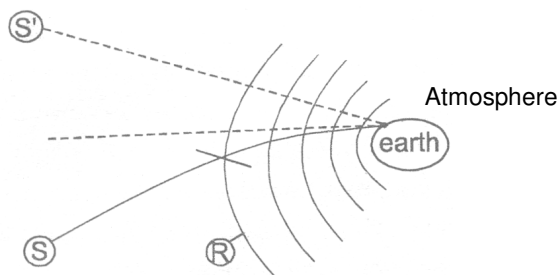

(iv) Twinkling of stars :

On a clear night, you might have observed the twinkling of a star, which is due to an atmospheric refraction of star light. The density of the atmosphere, as we know goes on decreasing as the distance above the sea level increase. For the sake of simplicity, air can be supposed to be made up of a very large number of layers show density decrease with the distance above the surface of the earth. Therefore, the light from a heavenly body, such as a star, goes on gradually bending towards normal as it travels through the earth's atmosphere. As the object is always seen in the direction of the light reaching the observer's eye, the star appears higher up in the sky than its actual position. Further, the densities of the various layers go on varying due to the convection current set up in air by temperature differences. Thus, the refractive index of layer of air at a particular level goes on changing.

Due to these variations in the refractive indices of the various layers of air, the light from a star passing through the atmospheric air changes its path from time to time and therefore, the amount of light reaching the eye is not always the same. This increase or decrease in the intensity of light reaching the eye results in the change in apparent position or twinkling of the star.

3.1 (c) Laws of Refraction :

There are two laws of refraction.

(i) The incident ray, the refracted ray and the normal at the point of incidence lie in the same plane.

(ii) $\frac{\sin i}{\sin r} = \text{constant}$ called refractive index denoted by ' μ '

The above law is called snell's law (willibrod snell). Eg. $\frac{\sin i}{\sin r} = \mu_2$

Here μ_2 is called refractive index of 2nd medium w.r.t 1st medium.

{Laws of refraction are valid for both types of surfaces i.e. for plane as well as spherical refracting surfaces.}

3.2 REFRACTIVE INDEX :

3.2 (a) Refractive Index in terms of Speed of Light :

The refractive index of a medium may be defined in terms of the speed of light as follows :

The refractive index of a medium for a light of given wavelength may be defined as the ratio of the speed of light in vacuum to its speed in that medium.

$$\text{Refractive index} = \frac{\text{Speed of light in vacuum}}{\text{Speed of light in medium}}$$

or
$$\mu = \frac{c}{v}$$

Refractive index of medium with respect to vacuum is also called absolute refractive index.

3.2 (b) Refractive Index in terms of Wavelength :

Since the frequency (ν) remain unchanged when light passed from one medium to another, therefore,

$$\mu = \frac{c}{v} = \frac{\lambda_{vac} \times \nu}{\lambda_{med} \times \nu} = \frac{\lambda_{vac}}{\lambda_{med}}$$

The refractive index of a medium may be defined as the ratio of wavelength of light in vacuum to its wavelength in that medium.

3.2 (c) Relative Refractive Index :

The relative refractive index of medium 2 with respect to medium 1 is defined as the ratio of speed of light (v_1) in the medium 1 to the speed of light (v_2) in medium 2 and is denoted by ${}_1\mu_2$.

$$\text{Thus, } {}_1\mu_2 = \frac{v_1}{v_2} = \frac{\lambda_1}{\lambda_2} = \frac{\mu_2}{\mu_1}$$

As refractive index is the ratio of two similar physical quantities, so it has no **unit and dimension**. **Factors on which the refractive index of a medium depends are**

- (i) Nature of the medium.
- (ii) Wavelength of the light used.
- (iii) Temperature.
- (iv) Nature of the surrounding medium

It may be noted that refractive index is a characteristic of the pair of the media and also depends on the wavelength of light, but is independent of the angle of incidence.

Physical significance of refractive index :

The refractive index of a medium gives the following two information's :

- (i) The value of refractive index gives information about the direction of bending of refracted ray. It tells whether the ray will bend towards or away from the normal.
- (ii) The refractive index of a medium is related to the speed of light. It is the ratio of the speed of light in vacuum to that in the given medium. For example, refractive index of glass is $3/2$. This indicates that the ratio of the speed of light in glass to that in vacuum is $2 : 3$ or the speed of light in glass is two-third of its speed in vacuum.

3.2 (d) Refractive Index in terms of apparent depth and real depth :

Whenever we observe the bottom of a swimming pool or a tank of clear water, we find that the bottom appears to be raised i.e. the apparent depth is less as compared to its real depth. The extent to which the bottom appears to be raised depends upon the value of refractive index of the refracting medium.

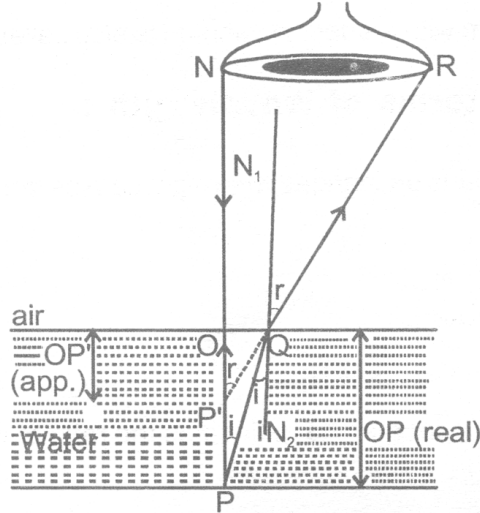

In above fig. $\angle PQN_2 = \angle i$ & $\angle N_1OR = \angle r$

$$\therefore \mu_a = \frac{\sin i}{\sin r}$$

$$\text{Or } \mu_w = \frac{\sin r}{\sin i} \quad \dots\dots\dots(1)$$

As $\angle N_1QR = \angle OP'Q = \angle r$ (corresponding angles)

$$\text{In } \triangle OP'Q \quad \sin r = \angle OP'Q = \frac{OQ}{P'Q} \quad \dots\dots\dots(2)$$

And $\angle i = \angle PQN_2 = \angle QPO$ (alt. Int. ($\angle s$))

$$\therefore \text{In } \triangle QOP \quad \sin i = \sin \angle OPQ = \frac{OQ}{PQ} \quad \dots\dots\dots(3)$$

So from (1) using (2) & (3)

$$\mu_w = \frac{OQ/P'Q}{OQ/PQ} = \frac{PQ}{P'Q} \quad \dots\dots\dots(4)$$

nearly normal direction of viewing angle i is very small

$PQ \cong PO$
 & $P'Q \cong P'O$
 \therefore from (4)

$$\mu_w = \frac{PO}{P'O} \Rightarrow \mu_w = \frac{\text{Real depth}}{\text{Apparent depth}}$$

3.2 (e) Refraction and Speed of Light :

The refraction of light occurs because light has different speed in different media. Speed of light is maximum in vacuum or air. It is less in any other medium. Denser in the medium lesser is the speed of light. Refractive index of a medium depends not only on its nature and physical conditions, but also on the colour or wavelength of light. It is more for violet light and less for red light (VIBGYOR).

To find refractive index of two media w.r.t. each other when their refractive indices w.r.t. air are given. A ray of light AB refracts from different medium as shown in figure below.

(i) For refractive index at interface A'B'

$${}_a\mu_w = \frac{\sin x}{\sin y} \dots\dots\dots(i)$$

(ii) For refractive index at interface C'D'

$${}_a\mu_g = \frac{\sin y}{\sin z} \dots\dots\dots(ii)$$

(iii) For refractive index at interface E'F'

$${}_g\mu_a = \frac{\sin z}{\sin x} \dots\dots\dots(iii)$$

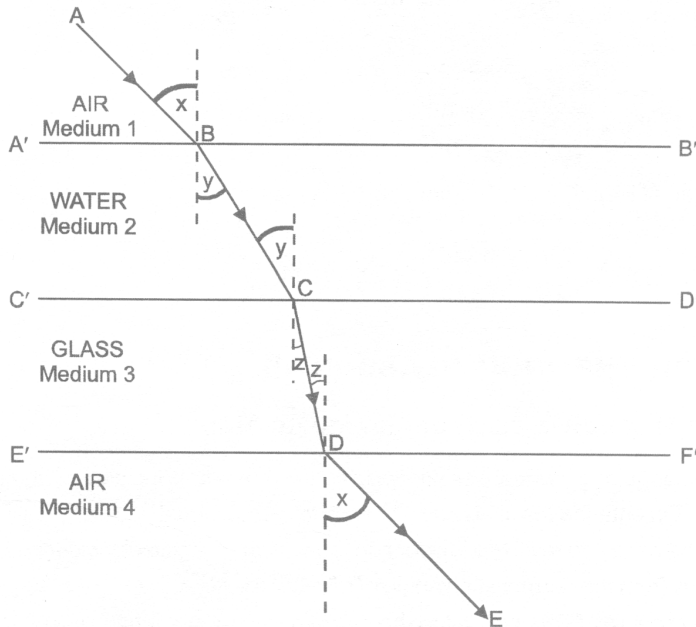

Multiply (1), (2) & (3)

$${}_a\mu_w \times {}_a\mu_g \times {}_g\mu_a = 1$$

$${}_g\mu_a = \frac{1}{{}_a\mu_w \times {}_a\mu_g}$$

$${}_w\mu_g = \frac{{}_a\mu_g}{{}_a\mu_w} \dots\dots\dots(iv) \quad \left(\text{as } \frac{1}{{}_g\mu_a} = {}_a\mu_g \right)$$

and on reciprocal

$${}_g\mu_w = \frac{{}_a\mu_w}{{}_a\mu_g} \dots\dots\dots(v)$$

∴ In general we can write as

$${}_2\mu_3 = \frac{{}_1\mu_3}{{}_1\mu_2}$$

$${}_3\mu_2 = \frac{{}_1\mu_2}{{}_1\mu_3}$$

Illustration :

Calculate the speed and wavelength of light (i) in glass & (ii) in air, when light waves of frequency 6×10^{14} Hz. travel from air to glass of $\mu = 1.5$.

Sol. Here $\nu = 6 \times 10^{14}$ Hz. $\mu = 1.5$

(i) In glass speed of light $V_g = \frac{V_a}{\mu} = \frac{3 \times 10^8}{1.5} = 2 \times 10^8$ m/s

Wavelength of light $\lambda_g = \frac{V_g}{\nu} = \frac{2 \times 10^8}{6 \times 10^{14}} = 3.3 \times 10^{-7}$ m.

(ii) In air speed of light $V_a = 3 \times 10^8$ m/s

Wavelength of light $\lambda_a = \frac{V_a}{\nu} = \frac{3 \times 10^8}{6 \times 10^{14}} = 5 \times 10^{-7}$ m.

3.3 REFRACTIN THROUGH GLASS SLAB :

3.3 (a) Refraction through a rectangular glass slab :

Consider a rectangular glass slab, as shown in figure. A ray AE is incident on the face PQ at an angle of incidence i . on entering the glass slab, it bends towards normal and travels along EF at an angle of refraction r . The refracted ray EF is incident on face SR at an angle of incidence r' . The emergent ray FD bends away from the normal at an angle of refraction e . Thus the emergent ray FD is parallel to the incident ray AR, but it has been laterally displaced with respect to the incident ray. There is shift in the path of light on emerging from a refracting medium with parallel faces.

Lateral shift :

Lateral shift is the perpendicular distance between the incident and emergent rays when light is incident obliquely on a refracting slab with parallel faces.

Factors on which lateral shift depends are :

- (i) Lateral shift is directly proportional to the thickness of glass slab.
- (ii) Lateral shift is directly proportional to the incident angle.
- (iii) Lateral shift is directly proportional to the refractive index of glass slab.
- (iv) Lateral shift is inversely proportional to the wavelength of incident light.

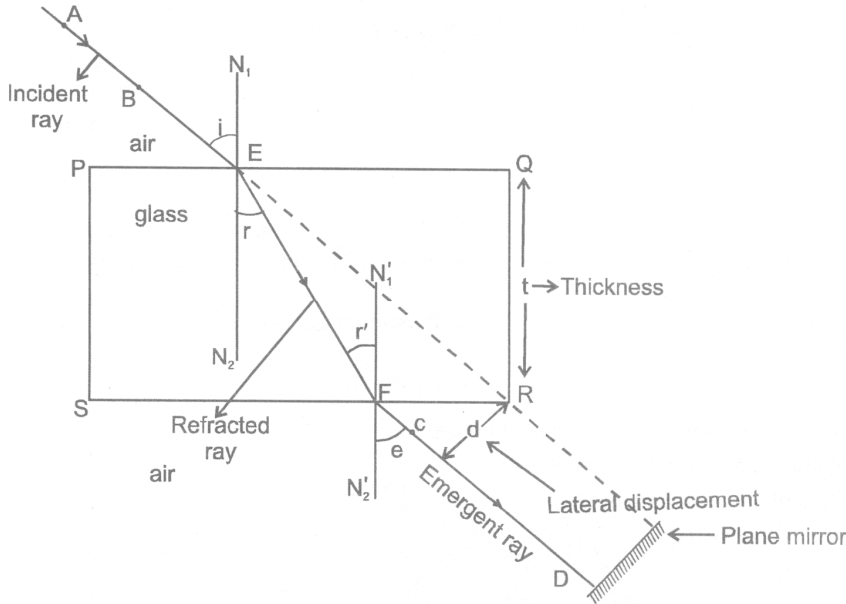

Figure : :Lateral shifting of light in glass slab

If a plane mirror is placed in the path of emergent ray FD then the path of the emergent ray along FD is reversed back, it follows the same path along which it was incident i.e. the incidence ray becomes the emergent ray & emergent ray becomes the incident ray. It is known as principle of reversibility of light.

Case - I : For light going from air to glass of point E.

$\angle i$ = angle of incident, $\angle r$ angle of refraction.

$${}_a\mu_g = \frac{\sin i}{\sin r} \dots\dots\dots(1) \quad ({}_a\mu_g = \text{absolute refractive index of glass})$$

Case - II : For light going from glass to air at point F.

$$\Rightarrow {}_g\mu_a = \frac{\sin r}{\sin e} \quad \text{where } \left\{ \begin{array}{l} \angle r = \text{angle of incidence} \\ \angle e = \text{angle of refraction} \end{array} \right\} \therefore \angle r = \angle e$$

$$\Rightarrow {}_g\mu_a = \frac{\sin r}{\sin i} \quad (\text{as } \angle e = \angle i)$$

$$\therefore \frac{1}{{}_g\mu_a} = \frac{\sin i}{\sin r} \dots\dots\dots(2)$$

\therefore From (1) & (2)

$${}_a\mu_g = \frac{1}{{}_g\mu_a} \Rightarrow [{}_a\mu_g \times {}_g\mu_a = 1]$$

${}_g\mu_a$

DAILY PRACTICE PROBLEMS # 3**OBJECTIVE DPP - 3.1**

1. R.I. of glass w.r.t. air is $\frac{3}{2}$, then the R.I. of air w.r.t. glass is -
 (A) $\frac{3}{4}$ (B) $\frac{2}{3}$ (C) $\frac{1}{3}$ (D) 3
2. Refractive index of glass with respect to air is 1.5 and refractive index of water with respect to air is $\frac{4}{3}$.
 What will be the refractive index of glass with respect to water ?
 (A) 1 (B) 1.5 (C) 1.125 (D) -10
3. The refractive index of a medium depends upon -
 (A) Nature of material of the medium
 (B) Optical density of the medium
 (C) Wavelength of light
 (D) All of these
4. If refractive index of water w.r.t. air is $\frac{4}{3}$, then refractive index of air w.r.t. water will be -
 (A) 4×3 (B) $\frac{3}{4}$ (C) $\sqrt{\frac{4}{3}}$ (D) $\sqrt{\frac{3}{4}}$
5. A ray of light is incident normally on a rectangular piece of glass. The value of angle of refraction will be -
 (A) 180° (B) 90° (C) 45° (D) 0°
6. A fish looking up through the water sees the outside world contained in a circular horizon. If the refractive index of water is $\frac{4}{3}$ and the fish is 12 cm below the surface, the radius of the circle is -
 (A) $12 \times 3 \times \sqrt{5}$ cm (B) $12 \times 3 \times \sqrt{7}$ cm (C) $12 \times \sqrt{5/2}$ cm (D) $12 \times \frac{3}{\sqrt{7}}$ cm
7. The speed of light in vacuum is 3.0×10^8 m/s. If the refractive index of a transparent liquid is $\frac{4}{3}$, then the speed of light in the liquid is -
 (A) 2.25×10^8 m/s (B) 3×10^8 m/s (C) 4×10^8 m/s (D) 4.33×10^8 m/s
8. A swimming pool appears to be 2m deep. Its actual depth is (μ for water = 1.33)-
 (A) 2.66 m (B) 2m (C) 2.34 m (D) 2.54 m

SUBJECTIVE DPP - 3.2

1. When light of two colour A and B is passed through a plane boundary, A is bent more than B. Which colour travel slowly in the second medium ?
2. What is the effect on the wavelength of light when it travel from rarer to denser medium ?
3. Light enters from air to glass having refractive index 1.5. What is the speed of light in glass ?
4. Light of wavelength 500 nm in air enters a glass plate of refractive index 1.5 find :
 - (a) Speed in glass.
 - (b) Frequency in glass.
 - (c) Wavelength of light in glass.

LIGHT

4.1 SPHERICAL LENSES :

A lens is a piece of transparent refracting material bounded by two spherical surface or one spherical and other plane surface.

A lens is the most important optical component used in microscopes, telescopes, cameras, projectors etc.

Basically lenses are of two types :

- (i) Convex lens or converging lens (ii) Concave lens or diverging lens

4.1 (a) Convex lens and its type :

A lens which is thick at the centre and thin at the edges is called a convex lens. The most common form of a convex lens has both the surfaces bulging out to the middle. Some forms of convex lens are shown in the figure.

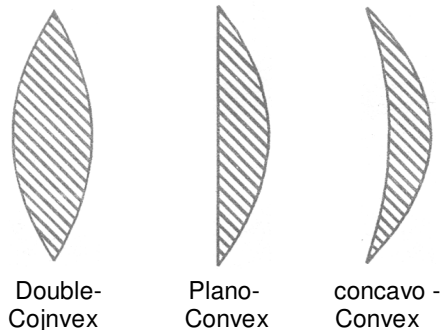

4.1 (b) Concave lens and its type :

A lens which is thin at the middle and thick at the edges is called a concave lens. The most common form of a concave lens has both the surfaces depressed inward at the middle. Some forms of concave lenses are shown in the figure.

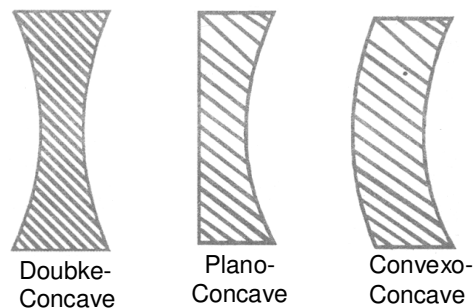

Figure : Different types of concave lens

4.1 (c) Definitions in connection with spherical lens :

(i) Centre of curvature (C) :

The centre of curvature of the surface of lens is the centre of the sphere of which it forms a part, because a lens has two surfaces, so it has two centers of curvature. In figure (a) & (b) points C_1 & C_2 are the centers of curvature.

(ii) Radius of curvature (R) :

The radius of curvature of the surface of a lens is the radius of the sphere of which the surface forms a part. R_1 & R_2 in the figure (a) & (b) represents radius of curvature.

(iii) Principle axis ($C_1 C_2$) :

It is the line passing through the two centers of curvature (C_1 & C_2) of the lens.

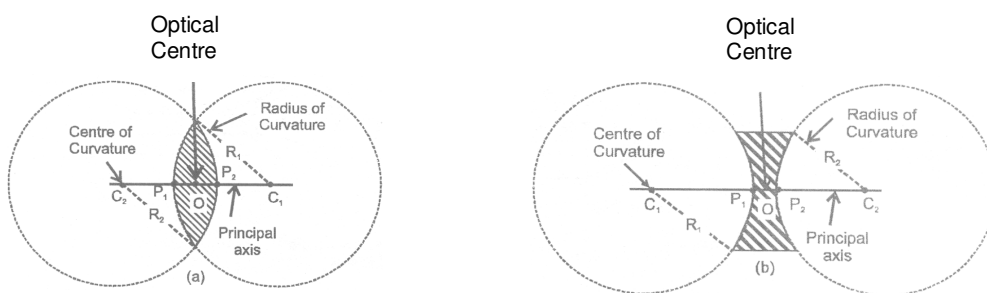

Figure : Characteristics of convex and concave lenses

(iv) Optical centre :

If a ray of light is incident on a lens such that after refraction through the lens the emergent ray is parallel to the incident ray, then the point at which the refracted ray intersects the principal axis is called the optical centre of the lens. In the figure O is the optical centre of the lens. It divides the thickness of the lens in the ratio of the radii of curvature of its two surfaces. Thus :

$$\frac{OP_1}{OP_2} = \frac{P_1C_1}{P_2C_2} = \frac{R_1}{R_2}$$

If the radii of curvature of the two surfaces are equal, then the optical centre coincides with the geometric centre of the lens.

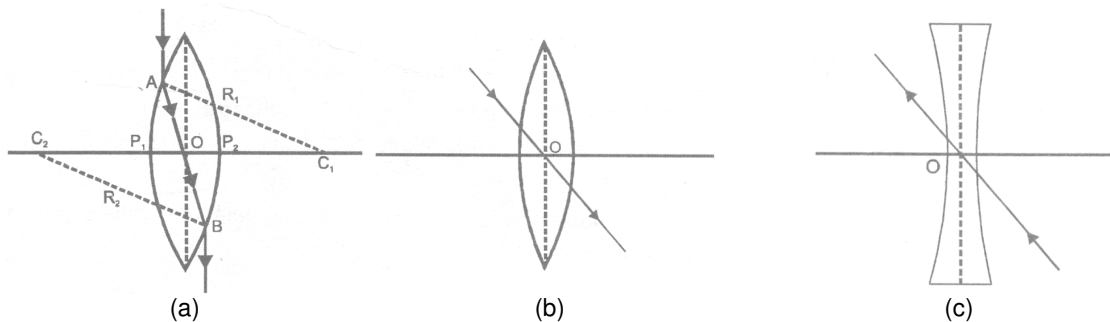

Figure : Ray diagram Showing lateral displacement

For a ray passing through the optical centre, the incident and emergent rays are parallel. However, the emergent ray suffers some lateral displacement relative the incident ray. The lateral displacement decrease with the decrease in thickness of the lens. Hence a ray passing through the optical centre of a thin lens does not suffer any lateral deviation, as shown in the figure (b & c) above.

(v) Principal foci and focal length :

(A) First principal focus :

It is a fixed point on the principal axis such that rays starting from this point (in convex lens) or appearing to go towards this point (concave lens), after refraction through the lens, become parallel to the principal axis. It is represented by F_1 or F' . The plane passing through this point and perpendicular to the principal axis is called the first focal plane. The distance between first principal focus and the optical centre is called the first focal length. It is denoted by f_1 or f' .

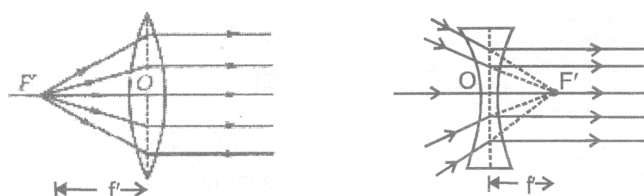

Figure : Ray diagram showing First principal focus

(B) Second principal focus :

It is a fixed point on the principal axis such that the light rays incident parallel to the principal axis, after refraction through the lens, either converge to this point (in convex lens) or appear to diverge from this point (in concave lens). The plane passing through this point and perpendicular to principal axis is called the second focal plane. The distance between the second principal focus and the optical centre is called the second focal length. It is denoted by f_2 or f .

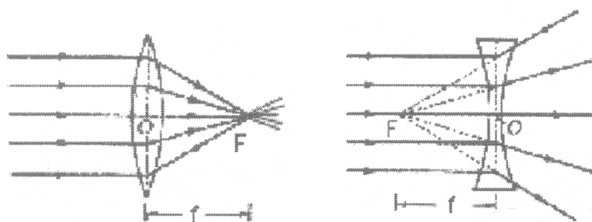

Figure : Ray diagram showing second principal focus

Generally, the focal length of a lens refers to its second focal length. It is obvious from the above figures, that the foci of a convex lens are real and those of a concave lens are virtual. Thus the focal length of a convex lens is taken positive and the focal length of a concave lens is taken negative.

If the medium on both sides of a lens is same, then the numerical values of the first and second focal length are equal. Thus

$$f = f'$$

(vi) Aperture :

It is the diameter of the circular boundary of the lens.

4.2 CONVEX LENS :

4.2 (a) Rules for the formation of images by Convex Lens :

The positions of the image formed by a convex lens can be found by considering two of the following rays (as explained below).

(i) A ray of light coming parallel to principal axis, after refraction through the lens, passes through the principal focus (F) as shown in the figure.

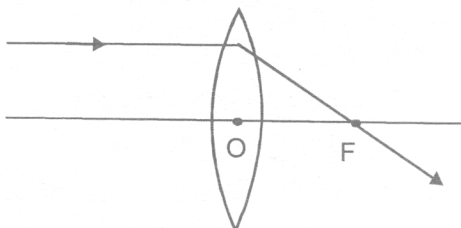
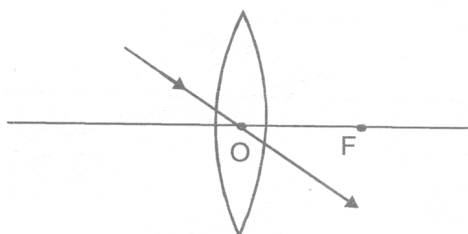
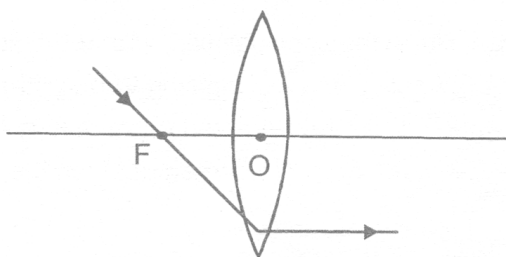

Figure : Convex Lens

(ii) A ray of light passing through the optical centre O of the lens goes straight without suffering any deviation as shown in the figure.



(iii) A ray of light coming from the object and passing through the principal focus of the lens after refraction through the lens, becomes parallel to the principal axis.



4.2 (b) Image formed by Convex Lens :

The position, size and nature of the image formed by a convex lens depends upon the distance of the object from the optical centre of the lens. For a thin convex lens, the various case of image formation are explained below :

(i) When object at infinity :

When an object lies at infinity, the rays of light coming from the object may be regarded as a parallel beam of light. The ray of light BO passing through the optical centre O goes straight without any deviation. Another parallel ray AE coming from the object, after refraction, goes along EA'. Both the refracted rays meet at A' in the focal plane of the lens. Hence, a real, inverted and highly diminished image is formed on the other side of the lens in its focal plane.

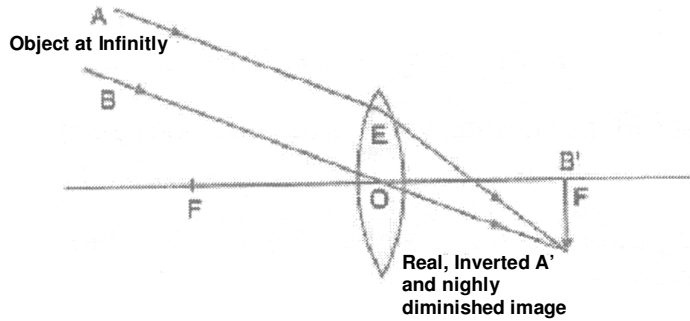

(ii) When object lies beyond 2F :

When an object lies beyond 2F, its real, invert and diminished image is formed between F and 2F on the other side of the lens as explained below :

A ray of light AE coming parallel to the principal axis, after refraction, passes through the principal focus F and goes along EF. Another ray AO passing through the optical centre O goes straight without suffering any deviation. Both the refracted rays meet at A'. Hence a real, inverted and diminished image is formed between F and 2F on the other side of the convex lens.

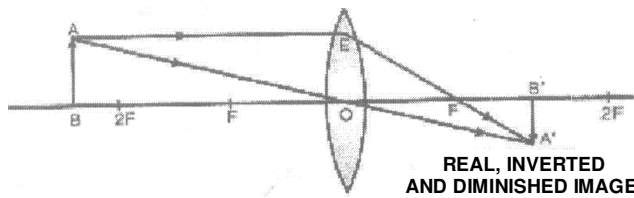

(iii) When object lies at 2F :

When an object lies at 2F, its real, inverted image having same size as that of the object is formed on the other side of the convex lens as explained below :

A ray of light AE coming parallel to the principal axis, after refraction, passes through the principal focus F and goes along EF, Another ray AO passing through the optical centre O goes straight without suffering any deviation. Both the refracted rays meet at A'. Hence a real, inverted image having the same size as the of the object is formed at 2F on the other side of the lens.

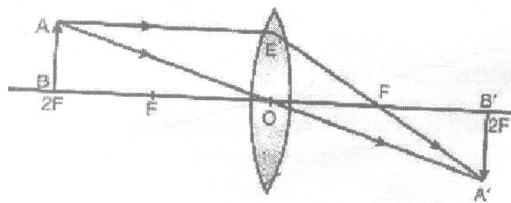

(iv) When object lies between F and 2F.

When an object lies between F and 2F in front of a convex lens, it real, inverted and magnified image is formed beyond 2F on the other side of the lens an explained below :

A ray of light AE coming parallel to the principal axis, after refraction, passes through the principal focus F and goes along EF. Another ray of light AO passing through the optical centre goes straight without any deviation. Both these refracted rays meet at A'. Hence a real, inverted and magnified image is formed beyond 2F on the other side of the lens.

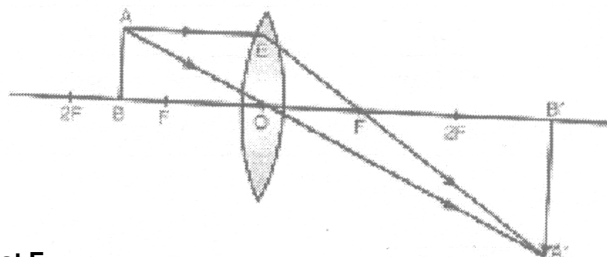

(v) When object lies at F :

When an object lies at the principal focus F of a convex lens, then its real, inverted and highly magnified image is formed at infinity on the other side of the lens as explained below :

A ray of light AE coming parallel to the principal axis, after refraction, passes through the principal focus F and goes along EF. Another ray of light AO passing through the optical centre O goes straight without any deviation. Both these refracted rays are parallel to each other and meet at infinity. Hence a real, inverted, highly magnified image is formed at infinity on the other side of the lens.

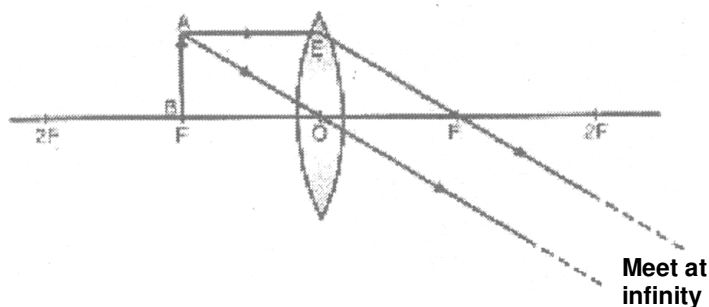

(vi) When object lies between O and F :

When an object lies between the optical centre O and the principal focus F of a convex lens, then its virtual, erect and magnified image is formed on the same side as that of the object as explained below :

A ray of light AE coming parallel to the principal axis, after refraction, passes through the principal focus F and goes along EF. Another ray of light AO passing through the optical centre goes straight without any deviation. Both these refracted rays appear to meet at A'. When produced backward. Hence virtual, erect and enlarged image is obtained on the same side of the lens.

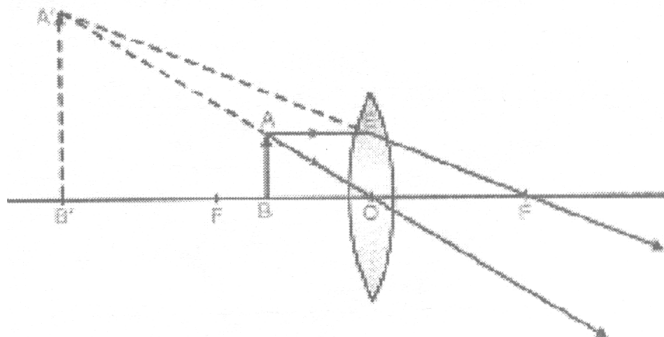

The results of image formation by a convex lens are summarised in the table:

Position of the object	Position of the image	Size of the image	Nature of the image
At infinity	At the focus F	Highly diminished	Real and inverted
Beyond 2F	Between F and 2F	Diminished	Real and inverted
At 2F	At 2F	Same size	Real and inverted
Between F and 2F	Beyond 2F	Magnified	Real and inverted
At F	At infinity	Highly magnified	Real and inverted
Between O and F	On the side of the object	Magnified	Virtual and erect

4.3 CONCAVE LENS

4.3 (a) Rules for the formation of images by Concave Lens :

The position of the image formed by a concave lens can be found by considering following two rays coming from a point object (as explained below).

- (i) A ray of light coming parallel to the principal axis, after refraction, appears to pass through the principal focus F of the lens, when produced backward as shown in figure (a).
- (ii) A ray of light passing through the optical centre O of the lens goes straight without suffering any deviation as shown in figure (b).

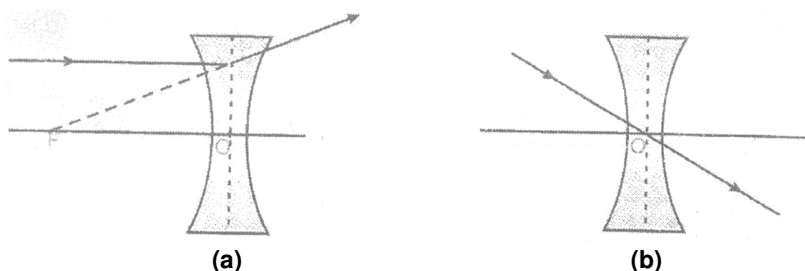

4.3 (b) Image formed by Concave Lens :

The image formed by a concave lens is always virtual, erect and diminished and is formed between the optical center O and the principal focus F of the lens. For a thin concave lens of small aperture, the cases of image formation are discussed below.

(i) When the object lies at infinity :

When an object lies at infinity in front of a concave lens, a virtual, erect, highly diminished image is formed at the principal focus F as explained below.

The rays of light AE and BD coming parallel to the principal axis of the concave lens, after refraction, go along EG and DH respectively. When extended in the back direction, these refracted rays appear to pass through the principal focus F. Hence a virtual, erect and highly diminished image is formed at the principal focus F.

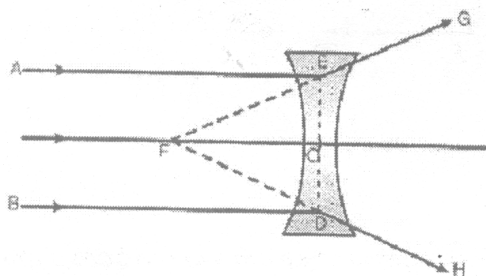

(ii) When the object lies between O and ∞ :

When an object lies at any position between the optical center O and infinity in front of a concave lens, the image formed is virtual, erect, demised and is formed between the optical centre O and the principal focus F as explained below.

A ray of light AE coming parallel to the principal axis, after refraction, goes along EG and appears to pass through principal focus when produced backward and another ray which is passing through the optical centre O goes straight without any deviation. Both these refracted rays appear to meet at A'. hence, a virtual erect, diminished image is formed between O and F.

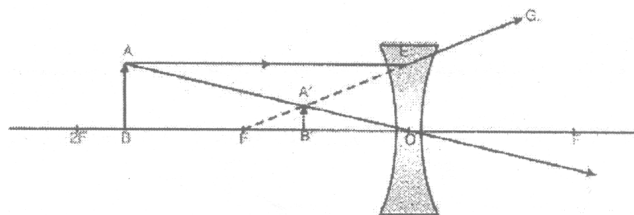

The summary of image formation by a concave lens for different positions of the object is given in table.

Position of the object	Position of the image	Size of the image	Nature of the image
At infinity	At F	Highly diminished	Virtual and erect
Between O and ∞	Between O and F	Diminished	Virtual and erect

4.4 POWER OF A LIES :

It is the measure of deviation produce by a lens. It is defined as the reciprocal of its focal length in metres.

Its unit is Dioptre (D) (f should always be in metres).

$$\text{Power (P)} = \frac{1}{\text{focallength (f in m)}}$$

Power of a convex lens is +ve (As it has a real focus and its focal length measured is +ve.)

Power of a concave lens is -ve (As it has a virtual focus and its focal length measured is -ve.)

NOTE :

(i) If two lenses are placed in contact, the combination has a power equal to the algebraic sum of the

powers of two lenses, $P = P_1 + P_2 \Rightarrow \frac{1}{f} = \frac{1}{f_1} + \frac{1}{f_2}$.

(ii) If two thin lenses are placed at d distance, then the combination has a power equal to-

$$P = P_1 + P_2 - dP_1P_2 \Rightarrow \frac{1}{f} = \frac{1}{f_1} + \frac{1}{f_2} - \frac{d}{f_1f_2}$$

Here, f_1 and f_2 are the focal length of lenses and f is focal length of f combination of lenses.

4.5 LENS FORMULA :

Relation between object distance u, image distance v and focal length f is : $\frac{1}{v} - \frac{1}{u} = \frac{1}{f}$.

4.6 LINEAR MAGNIFICATION :

Linear magnification (m) is defined as the ratio of the size of the image to the size of the object.

$$m = \frac{A'B'}{AB} = \frac{h_2}{h_1} = \frac{\text{height of image}}{\text{height of object}}, \quad \text{also } m = \frac{v}{u} \quad \begin{array}{l} \text{if } m \text{ is } + \text{ve (image is virtual \& erect).} \\ \text{if } m \text{ is } - \text{ve (image is real \& inverted)} \end{array}$$

DAILY PRACTICE PROBLEMS # 4**OBJECTIVE DPP - 4.1**

1. To get a real and inverted image of the same size as that the object should be placed in front of the convex lens at:

(A) F	(B) 2F
(C) between F and 2F	(D) away from 2F, where F is focal length
2. A spherical mirror and a spherical lens have each focal length of - 10cm. The mirror and lens are :

(A) both convex	(B) both concave
(C) mirror is convex and lens is concave	(D) mirror is concave and lens is convex
3. The power of lens having focal length 50 cm is :

(A) $\frac{1}{2}$ D	(B) 2D	(C) 3D	(D) 0.2 D
---------------------	--------	--------	-----------
4. The focal length of a lens of power - 2.0 D is :

(A) -2.0 m	(B) 0.2 m	(C) 0.5 m	(D) 0.5 m
------------	-----------	-----------	-----------
5. Two lenses of +5D and -5D are placed in chose contact. The focal length of the combination is :

(A) Zero	(B) ∞	(C) Zero or ∞	(D) None of these
----------	--------------	----------------------	-------------------
6. A student needs a lens of power -2.0 dioptre to correct his distant vision. The focal length of the given lens is :

(A) + 50 cm	(B) -50 cm	(C) 10 cm	(D) -10 cm
-------------	------------	-----------	------------
7. Focal length of coloured goggles (without number) i :

(A) zero	(B) infinity
(C) between zero & infinity	(D) None of these
8. Where should an object be placed so that a real and inverted image of very large size is obtained, using a convex lens ?

(A) At the focus	(B) At 2F	(C) Between F & 2F	(D) Beyond 2F
------------------	-----------	--------------------	---------------
9. A convex lens is :

(A) Thicker at the middle, thinner at the edges
(B) Diverging
(C) Thicker at the edges thinner in the middle
(D) Of uniform thickness everywhere

10. A glass rod of refractive index 1.42 is immersed in kerosene. The refractive index of kerosene is 1.42. Then the rod will :
- (A) appear bent (B) appear raised above the liquid
(C) become invisible (D) none of the above
11. The power of a lens whose focal length is 25 cm is :
- (A) 4 Dioptre (B) 25 Dioptre (C) 0.04 Dioptre (D) 2.5 Dioptre
12. A thin lens is made with a material having refractive index $\mu = 1.5$. Both the side are convex. It is dipped in water ($\mu = 1.33$), it will be have like :
- (A) a convergent lens (B) a divergent lens
(C) a rectangular slab (D) a prism
13. Choose the correct option :
- (A) If the final rays are converging, we have a real image.
(B) If the incident rays are converging, we have a real image.
(C) If the image is virtual, the corresponding object is called a virtual object.
(D) The image of a virtual object is called a virtual image.
14. A convex lens forms a real image of a point object placed on its principal axis. If the upper half on the lens is painted black :
- (A) the image will be shifted backward
(B) the image will not be shifted
(C) the intensity of the image will decrease
(D) both (B) & (C)
15. The minimum distance between an object and its real image formed by a convex lens of focal length f is :
- (A) f (B) $2f$ (C) $3f$ (D) $4f$

SUBJECTIVE DPP - 4.2

1. A convex lens forms a real and inverted image of a needle at a distance of 50 cm from the lens. Where should be needle be placed in front of the convex lens so that this image is of the same size as the object. Also find the power of lens.
2. It is possible for a lens to act as a convergent lens in one medium and a divergent lens in another ?
3. What is the power of a concave lens of focal length 50 cm ?
4. Two lenses of power + 3.5 D and -2.5 D are placed in contact. Find the power and focal length of the lens combination.

LIGHT

5.1 HUMAN EYE :

The human eye is one of the most sensitive sense organs of sight which enables us to see the wonderful world of light and colour around us. It is like a camera having a lens system and forming an inverted, real image on a light sensitive screen inside the eye. The structure and working of the eye is as follows :

5.1 (a) Structure and Working of Human Eye :

The human eye has the following parts :

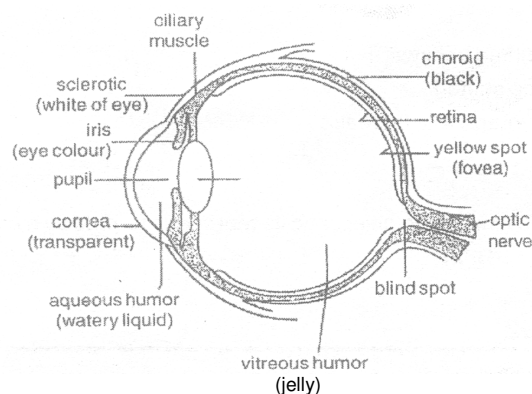

- (i) **Cornea** : It is the transparent spherical membrane covering the front of the eye.
- (ii) **Iris** : It is the coloured diaphragm between the cornea and lens.
- (iii) **Pupil** : It is the small hole in the iris.
- (iv) **Eye lens** : it is a transparent lens made of jelly like material.
- (v) **Ciliary muscles** : These muscles hold the lens in positions.
- (vi) **Retina** : it is the back surface of the eye.
- (vii) **Blind spot** : it is the point at which the optic nerve leaves the eye. An image formed at this point is not sent to the brain.
- (viii) **Aqueous humor** : It is clear liquid region between the cornea and the lens.
- (ix) **Vitreous humor** : The space between eye lens and retina is filled with another liquid called vitreous humor.

In the eye, the image is formed on the retina by successive refractions at the cornea, the aqueous humor, the lens and the vitreous humor. Electrical signals then travel along the optic nerve to the brain to be interpreted. In good light, the yellow spot is most sensitive to detail and the image is automatically formed there.

5.1 (b) Power of Accommodation :

The image of the objects at different distances from the eye are brought to focus on the retina by changing the focal length of the eye-lens, which is composed of fibrous jelly-like material, can be modified to some extent by the ciliary muscles.

5.1 (c) Near Point and Far Point :

The nearest point at which a small object can be seen distinctly by the eye is called the near point. For a normal eye, it is about 25 cm and is denoted by the symbol D.

With advancing age, the power of accommodation of the eye decreases as the eye lens gradually loses its flexibility. For most of the old persons aged nearly 60 years, the near point is about 200 cm and corrective glasses are needed to see the nearby objects clearly.

The farthest point upto which our eye can see objects clearly, without any strain on the eye is called the far point. For a person with normal vision, the far point is at infinity.

5.1 (d) Least Distance of Distinct Vision :

The minimum distance of an object from the eye at which it can be seen most clearly and distinctly without any strain on the eye, is called the least distance of distance of distinct vision. For a person with normal vision, it is about 25 cm and is represented by the symbol D, i.e.
least distance of distinct vision = D = 25 cm.

5.1 (e) Persistence of Vision :

The image formed on the retina of the eye does not fade away Instantaneously, when the object is removed from the sight. The impression (or sensation) of the object remains on the retina for about $(1/16)^{\text{th}}$ of a second, even after the object is removed from the sight. This continuance of the sensation of eye is called the persistence of vision.

Let a sequence of still pictures is taken by a movie camera. If the sequence of these still pictures is projected on a screen at a rate of 24 images or more per second then the successive impression of the images on the screen appear to blend or merge smoothly into one another. This is because an image (or a scene) on the screen appears just before the impression of previous image on the retina is lost. Hence, the sequence of images blend into one another giving the impression of a moving picture. This principle is used in motion picture projection or in cinematography.

5.1 (f) Colour - Blindness :

The retina of our eye has large number of light sensitive cells having shapes of rods and cones. The rod-shaped cells responds to the intensity of light with different of brightness and darkness were as the cone shaped cells respond to colour. In dim light rods are sensitive, but cones are sensitive only bright. The cones are sensitive to red, green and blue colour of light to different extents.

Due to genetic disorder, some persons do not possess some cone-shaped cells that responds to certain specific colours only. Such persons cannot distinguish between certain colour but can see well otherwise. Such persons are said to have colour-blindness. Driving licenses are generally not issued to persons having colour-blindness.

5.1 (g) Colour Perception of Animals :

Different animals have different colour perception due to different structure of rod shaped cells and cone shaped cells. For example, bees have some cone-shaped cells that are sensitive to ultraviolet. Therefore bees can see objects in ultraviolet light and can perceive colours which we cannot do.

Human beings cannot see in ultraviolet light as their retina do not have cone-shaped cells that are sensitive to ultraviolet light.

The retina of chicks have mostly cone shaped cells and only a few rod shaped cells. AS rod shaped cells are sensitive to bright light only, therefore, chicks wake up with sunrise and sleep in their resting place by the sunset.

5.1 (h) Cataract :

Sometimes due to the formation of a membrane over the crystalline lens of some people in the old age, the eye lens becomes hazy or even opaque. This is called cataract. It results in decrease or loss in vision of the eye. Cataract can be corrected by surgery leading to normal vision.

5.2 DEFECTS OF VISION AND THEIR CORRECTION :

People with normal vision can focus clearly on very distant objects. We say their far point is at infinity.

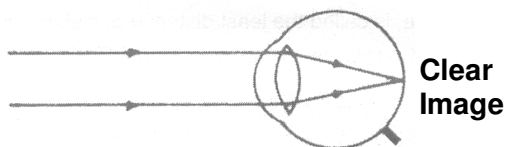

People with normal vision can focus clearly on near objects upto a distance of 25 cm. We say their near point is at a distance 25 cm from the eye.

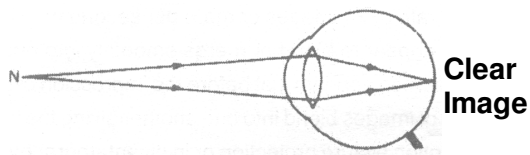

But there are some defected due to eye irregularities which are as follows :

5.2 (a) Short Sightedness (or Myopia):

A person who can see the near objects clearly but cannot focus on distant objects in short sightedness. The far point of a short-sighted person may be only a few metres rather than at infinity. This defect occurs if a person's eyeball is larger than the usual diameter. In such a case, the image of a distant object is formed in front of the retina as shown in the figure. It is because the eye lens remain too converging, forming the image of the object in front of the retina.

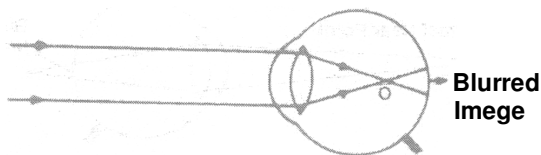
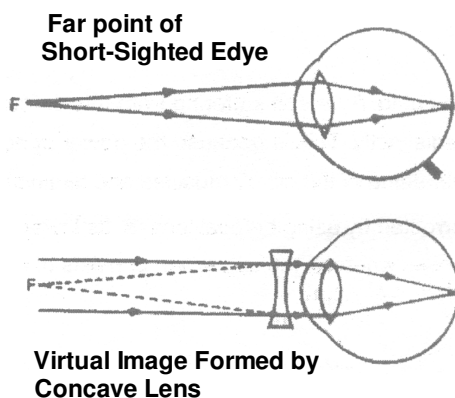

Figure : Ray diagram in case of short sightedness

To correct short-sighted vision, a diverging lens (concave lens) of suitable focal length is placed in front of the eyes as shown in figure. The rays of light from a distant object are diverged by the concave lens so that the final image is formed at the retina. If the object is very far off (i.e. $u \approx \infty$), then the focal length of the concave lens is so chosen that a virtual image of the distant object is formed at the far point F of the short-sighted eye. Therefore, the rays of light appear to come from the image at the far point F of the short-sighted eye and not from the more distant object.



Note that the focal length of the lens for a short-sighted person is equal to the negative value of the person's far point.

5.2 (b) Far Sightedness (or Hyperopia or Hypermetropia) :

A person who can see distant objects clearly but cannot focus on near objects is farsighted, whereas the normal eye has a near point of about 25 cm. A farsighted person may have a near point several metres from the eyes. This defect may occur if the diameter of the person's eyeball is smaller than the usual or if the lens of the eye is unable to curve when the ciliary muscles contract. In such a case, for an object placed at the normal near point (i.e. 25 cm from the eye), the image of the object is formed behind the retina as shown in figure (i). It is because the lens of the eye is not sufficiently converging to focus the object located at the normal nearer point.

A farsighted person has the normal far point but needs a converging lens in order to focus objects which are as close as 25 cm. The converging lens of correct focal length will cause the virtual image to be formed at the actual near point of the farsighted person's eye as shown in figure (iii).

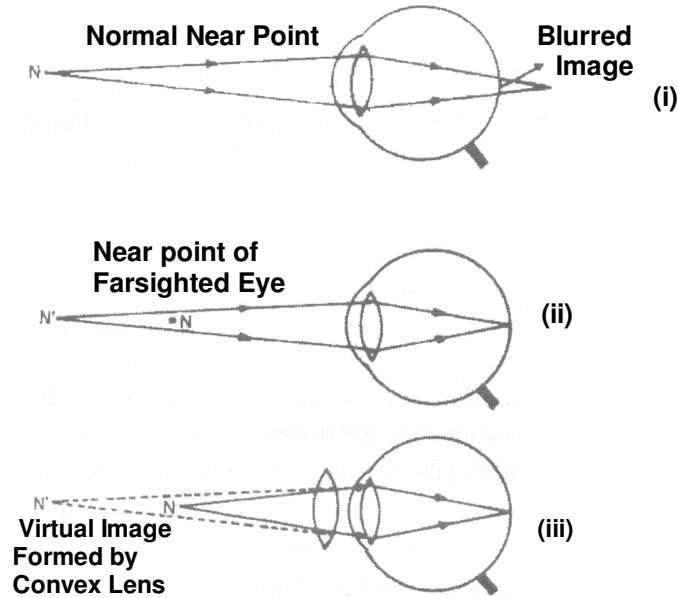

Figure : Correction of far sightedness by convx lens

5.2 (c) Prsbyopia :

This defect arises with aging. A person suffering from this defect can see neither nearby objects nor distant objects clearly/distinctly. This is because the power of accommodation of the eye decreases due to the gradual weakening of the ciliary muscles and diminishing flexibility of the eye lens. This defect can be corrected by using bi-focal lenses. Its lower part consists of a convex lens and is used for reading purpose whereas the upper part consists of a concave lens and in used for seeing distant objects.

5.2 (d) Astigmatism :

A person suffering from this defect cannot simultaneously focus on both horizontal and vertical lines of wire gauze.

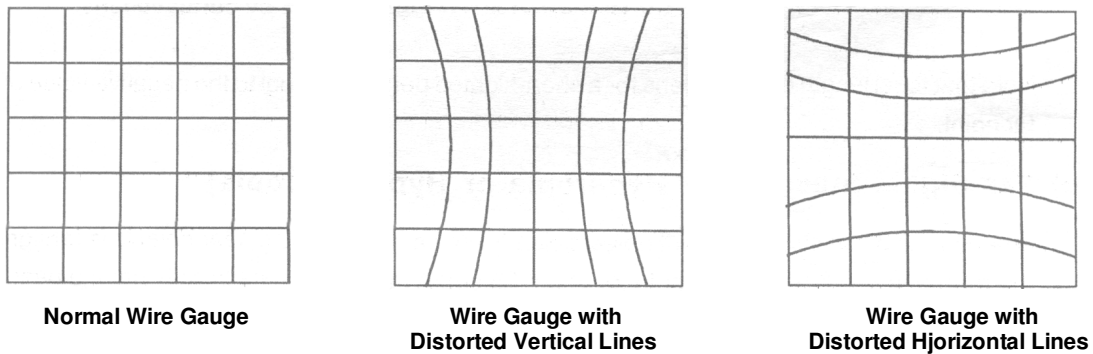

This defect arises due to the fact that the cornea is not perfectly spherical and has different curvatures for horizontally and vertically lying objects. Hence, objects in on direction are well focused whereas objects in the perpendicular direction are not well focused. This defect can be corrected by using cylindrical lenses. The cylindrical lenses are designed in such a way so as to compensate for the irregularities in the curvature of cornea.

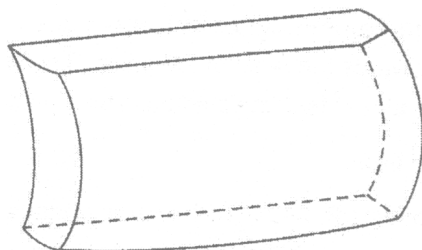
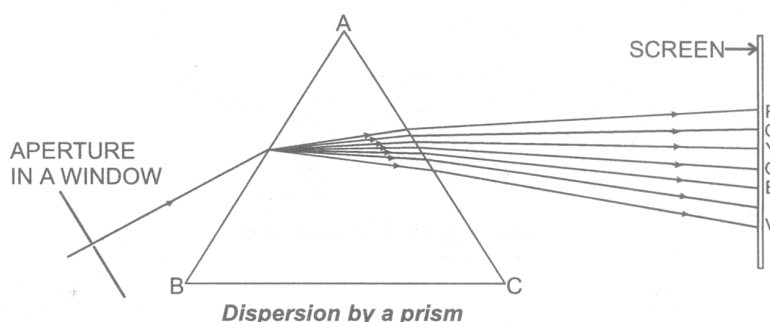

Figure : Cylindrical lens

5.3 SPECTRUM AND COLOURS :

5.3 (a) Dispersion of Light through a Prism :



The phenomenon of splitting of white light into its constituent colours is known as dispersion of light. It is discovered by Newton.

Colour	Frequency in 10^{14} Hz	Wavelength (nearly)
Violet	6.73 – 7.5	400 Å to 4460 Å
Indigo	6.47 – 6.73	4460 Å to 4640 Å
Blue	6.01 – 6.47	4640 Å to 5000 Å
Green	5.19 – 6.0	5000 Å to 5780 Å
Yellow	5.07 – 5.19	5780 Å to 5920 Å
Orange	4.84 – 5.07	5920 Å to 6200 Å
Red	3.75 – 4.84	6200 Å to 8000 Å

Dispersion takes place because light of different colours have different speed in a medium. Therefore the refractive index of glass is different for different colours of light. When white light is incident on the first surface of a prism and enters it, light of different colours is refracted or deviated through different angles. Thus the dispersion or splitting of white light into its constituent colours takes place.

NOTE : From the definition of refractive index

$$\mu_{\text{glass}} = \frac{\text{speed of light in air}}{\text{speed of light in glass}}$$

The speed of light for different colours is different in glass (medium). The speed of violet light is minimum and the speed of red light is maximum. Therefore

$$\mu_{\text{violet}} > \mu_{\text{red}}$$

But $\mu = \frac{\sin i}{\sin r}$ or $\sin r = \frac{\sin i}{\mu}$

Therefore, the angle of refraction is minimum for light of violet colour and maximum for light of red colour. Each colour is deviated towards the base of the prism. The violet is deviated the most and the red is deviated the least. As a matter of fact the colours in the spectrum do not have any sharp boundaries.

Recomposition of white light :

For this experiment, two prism P_1 and P_2 of the same material and of the same refracting angle A are arranged as shown in figure. Sunlight from a narrow slit S falls on the first prism P_1 with its base downwards and gets dispersed into constituent colours (VIBGYOR) and the bending takes place downwards. Now this dispersed light falls on the second prism P_2 with its base upwards so that it deviates the light upwards.

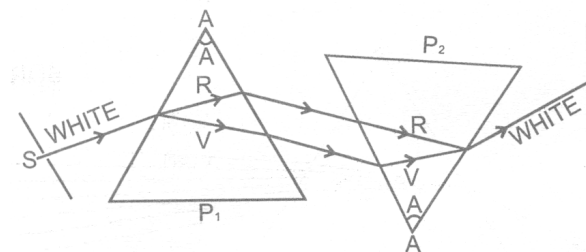

Recomposition of white light

It is found that the light coming out of the second prism P_2 is almost white and is in direction parallel to the direction of light incident of the first prism P_1 . In fact, the two prisms P_1 and P_2 combined together effectively acts like a parallel sided glass slab. This shows that the Prism P_1 simply disperses the white light into its constituent colours and the prism P_2 recombines these colours to form white light. The prism P_1 is called **dispersing-prism** and the prism P_2 is known as **recombination-prism**.

5.4 SCATTERING OF LIGHT :

When light falls on tiny particles then diffused reflection takes place and light spreads in all possible direction. This phenomenon is known as scattering of light.

Small particles scatter mainly blue light. When size of the particle increases then the light of longer wavelength also scatter. The path of a beam of light passing through a true solution is not visible. However, its path becomes visible through a colloidal solution where size of the particles is relatively larger. Rayleigh proved that the intensity of scattered light is inversely proportional to the fourth power of the wavelength, provide the scatters is smaller in size than the wave length of light :

$$\text{scattering} \propto \frac{1}{\lambda^4}$$

5.4 (a) Tyndall Effect :

The earth's atmosphere is a heterogeneous mixture of minute particles. These particles include smoke, tiny water droplets, suspended particles of dust and molecules of air. When a beam of light strikes such fine particles, the path of the beam become visible. The light reaches us after being reflected diffusely by these particles. The phenomenon of scattering of light by the colloidal particle gives rise to tyndall effect. This phenomenon is seen when a fine beam of sunlight enters a smoke filled room through a small hole. Thus, scattering or light makes the particles visible. Tyndall effect can also be observed when sunlight passes through a canopy of a dense forest. Here, tiny water droplets in the mist scatter light.

5.4 (d) Phenomena based upon Scattering of Light

(i) Colour of the clear sky is blue :

The molecules of air and other fine particles in the atmosphere have size smaller than the wavelength of visible light. These are more effective in scattering light of shorter wavelength at the blue end than light of longer wavelength at the red end. The red light has a wavelength about 1.8 times greater than blue light. Thus, when sunlight passes through the atmosphere, the fine particles in air scatter the blue colour more strongly than red. The scattered blue light enters our eyes. If the earth had no atmosphere, there would not have been any scattering. Then, the sky would have looked dark. The sky appears dark to a passenger flying at very high altitudes, as scattering is not prominent at such heights.

(ii) Colours of the sun at sunrise and sunset :

Let us do an activity to understand the colour of sun at sunrise and sunset. Place a strong source (S) of white light at the focus of converging lens (L_1). This lens provides a parallel beam of light. Allow the light beam to pass through a transparent glass tank (T) containing clear water. Allow the beam of light to pass through a circular hole (C) made in a cardboard. Obtain a sharp image of the circular hole on a screen (MN) using a second converging lens (L_2). Dissolve 200 g of sodium thiosulphate in 2 L of clear water taken in the tank. Add 1 to 2 mL of concentrated sulphuric acid to the water.

We observe the microscopic sulphur particles precipitate in 2 to 3 minutes. As sulphur particles begin to form we can observe the blue light from the three sides of the glass tank.

It is due to scattering of short wavelengths by minute colloidal sulphur particles. We observe that the colour of the transmitted light from the fourth side of glass tank facing the circular tank at first is orange red colour and then bright crimson red colour of the screen. Light from the sun travels a relatively short distance. At noon, the sun appears white as a little of blue and violet colours are scattered. Near the horizon, most of the blue light shorter wavelength are scattered away by the particles. Therefore, the light that reaches our eye is of longer wavelength. This gives rise to the reddish appearance of the sun.

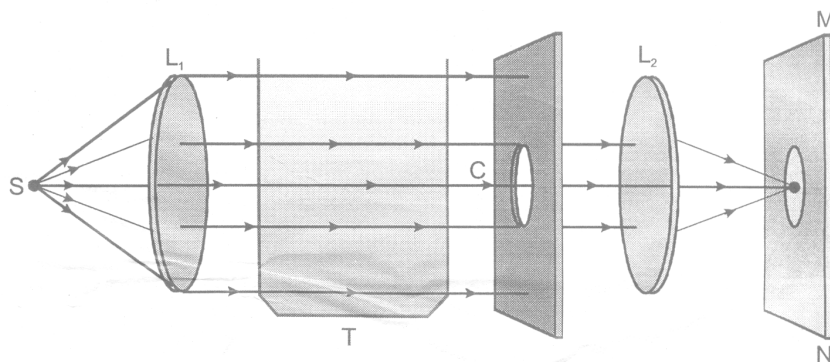

DAILY PRACTICE PROBLEMS

5 OBJECTIVE DPP - 5.1

1. The focal length of eye lens controlled by-
 (A) Iris (B) Cornea (C) Ciliary muscles (D) Optic nerve

2. A white light falls on a glass prism, the least deviated colour is -
 (A) Violet (B) Orange (C) Red (D) Yellow

3. Blue colour of sky is due to -
 (A) dispersion of light (B) scattering of light (C) refraction of light (D) reflection of light

4. Rainbow is formed due to -
 (A) reflection and dispersion of light through a water droplet
 (B) Total internal reflection, refraction and dispersion of light through a water droplet
 (C) only dispersion of light
 (D) only refraction of light

5. Power of accommodation (max. variation in power of eye lens) of a normal eye is about -
 (A) 1D (B) 2D (C) 3D (D) 4D

6. Dispersion of light by a prism is due to the change in -
 (A) frequency of light (B) speed of light (C) scattering (D) none of these

7. Least distance of distinct vision of a long-sighted man is 40 cm. He wishes to reduce it to 25 cm by using a lens, the focal length of the lens is -
 (A) $+\frac{200}{3}$ cm (B) $-\frac{200}{3}$ cm (C) + 200 cm (D) - 200 cm

8. Which of the following colour has the least wave length ?
 (A) red (B) orange (C) violet (D) Blue

9. Convex lens of suitable focal length can correct -
 (A) short sightedness (B) long sightedness (C) presbyopia (D) astigmatism

10. The focal length of human eye lens is -
 (A) 2.5 cm (B) 25 cm (C) 25m (D) ∞

SUBJECTIVE DPP - 5.2

1. What are the causes of near sightedness ?
2. How is the amount of light entering our eye controlled?
3. Which colour bends the maximum from its path when a beam of white light is incident on it ?

ANSWERS

(Objective DPP 1.1)

Q.	1	2	3	4	5	6	7	8
A.	B	A	D	A	D	C	B	C

(Subjective DPP 2.1)

1. $\theta = 130^\circ$ 2. 60°

Q.	1	2	3	4	5	6	7	8
A.	B	B	B	D	D	A	C	C

(Subjective DPP 2.1)

1. (a) $v = -30$ cm, $m = -3$ (b) $V = 15$ cm, $m = 3$ 3. -30 cm

(Objective DPP 3.1)

Q.	1	2	3	4	5	6	7	8
A.	B	C	D	B	D	D	A	A

(Subjective DPP 3.2)

3. $2 \times 10^8 \text{ ms}^{-1}$ 4. (a) $2 \times 10^8 \text{ ms}^{-1}$ (b) $6 \times 10^{14} \text{ Hz}$ (c) $\frac{10^{-6}}{3} \text{ m}$

(Objective DPP 4.1)

Q.	1	2	3	4	5	6	7	8	9	10	11	12	13	14	15
A.	B	B	B	C	B	B	B	A	A	C	A	A	A	D	D

(Subjective DPP 4.2)

1. $u = 50$ cm, $P = 4D$ 2. Yes 3. $-2D$

4. Power = $1D$, Focal length = 1m

(Objective DPP 5.1)

Q.	1	2	3	4	5	6	7	8	9	10
A.	C	C	B	B	D	B	A	C	B	A

ELECTRICITY

PL - 6

Electricity has an important role in modern society. In a span of more than 100 years, electricity has indeed, developed from a mere experimental activity in the laboratory into one of the most convenient and widely used forms of energy in the world. One of the practical advantages of electricity as a form of energy, is that it can readily be transmitted over considerable distance with relatively small loss in energy. This makes it possible to supply electricity from a central generating plant to any location.

6.1 ELECTRIC CHARGE :

When we run our shoe across a carpet and reach for a metal doorknob, we can be zapped by an annoying spark of electricity. The answers to this lie in the branch of Physics called Electrostatics. The word electricity comes from the Greek word electron, which means "amber." Amber is petrified tree resin and it was well known to the ancients that if we rub an amber rod with a piece of cloth, the amber attracts small pieces of dry leaves or paper. A piece of hard rubber, a glass rod or a plastic comb rubbed with cloth also display this "amber effect" or static electricity or frictional electricity as we call it today.

Experiments show that there are exactly two kinds of electric charges :

(i) Negative charge (ii) Positive charge

This also shows that unlike charges attract each other while like charges repel each other.

The S.I. unit of electric charge is coulomb. It is denoted by symbol **C**

6.1 (a) Conductors and Insulators :

In some substances, the electric charges can flow easily while in others they cannot. So, all the substances can be divided mainly into two electrical categories: Conductors and insulators.

(i) **Conductors** : Those substances through which electric charges can flow, are called conductors. But the flow of electric charges is called electricity. All the metals like silver, copper and aluminum etc., are conductors. Carbon, in the form of graphite, is a conductor and the aqueous solution (water solution) of salts are also conductors. The human body is a fairly good conductor. All the conductors (like metals) have some electrons which are loosely held by the nucleus of their atoms. These electrons are called "free electrons" and can move from one atom to another atom throughout the conductor. The presence of "free electrons" in a substance makes it a conductor of electricity.

(ii) **Insulators** : Those substances through which electric charges cannot flow, are called insulators. In other words, those substances through which electricity cannot flow are called insulators. Glass, ebonite, rubber, most of the plastics, paper, dry wood, cotton, mica, bakelite, and dry air, are all insulators because they do not allow electric charges (or electricity) to flow through them. In the case of charged insulators like glass, ebonite etc., the electric charges remain bound to them and do not move away.

The electrons present in insulators are strongly held by the nuclei of their atoms. Since there are “no free electron” in an insulator which can move from one atom to another, so insulator does not allow electric charges (or electricity) to flow through it.

NOTE : Those substance whose conductivity lies in between the conductors and insulators are called semi-conductors.

For e.g. : Silicon, germanium are semi - conductors.

6.2 ELECTRIC FIELD AND ELECTRIC POTENTIAL :

The flow of electricity in a circuit can be regarded very much similar to the flow of water in a pipe. The water pipe is analogous to the electric conductor, while the amount of water flowing through a given point per second corresponds to electric current. Figure below show how the pump (P) builds up and maintains pressure by lifting water from a tank (B) to the reservoir (A) through the pipe (R). Note that along the pipe, different points are at different pressure. Water in the pipe flow from say, a point C to D only when the pressure at C is greater than that at D. Thus, when the valve (V) is open, water start flowing into the reservoir.

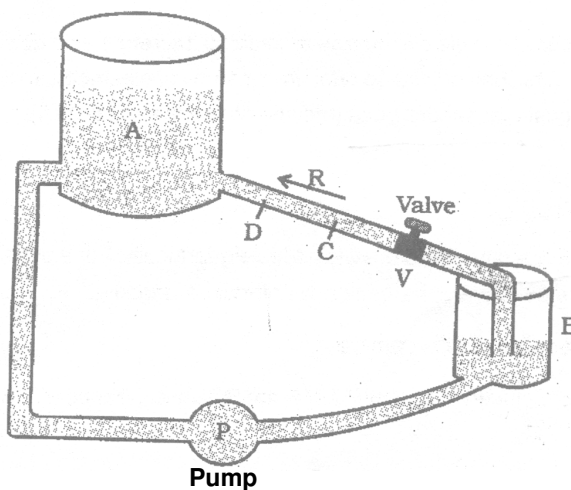

In the same manner electrons will move along a wire only if there is a difference of electric pressure called potential difference along the conductor. This difference of potential produced by the cell or a battery, which acts like a water pump in the circuit.

The chemical action within the cell generates the difference in potential between the electrodes, which sets the electrons in motion and produces the current. We define the electric potential difference between the two points, A and B, on a conductor carrying current, as the work done to move a unit charge from A to B. Potential difference (V) between the points A and B = work done (W)/charge (Q). The unit of potential is volt, named after a scientist Alessandro (1745 - 1827).

One volt is the potential difference when 1 joule of work is done to move a charge of 1C.

6.2 (a) Electric Field :

Electric field due to a given charge is defined as the space around the charge in which electrostatic force of attraction or repulsion due to charge can be experienced by any other charge. If a test charge experiences no force at a point, the electric field at that point must be zero.

Electric field intensity at any point is the strength of electric field at that point/ It is defined as the force experienced by unit positive charge placed at that point.

If \vec{F} is the force acting on a test charge $+q_0$ at any point r , then electric field intensity at this point is given by

$$\vec{E}(r) = \frac{\vec{F}}{q_0}$$

Electric field is a vector quantity and its S.I. unit is Newton per coulomb or N/C.

6.2 (b) Electric Potential :

The electric potential at a point in an electric field is defined as the amount of work done in moving a unit +ve charge from infinity to that point, without acceleration or without a change in K.E., against the electric force due to the electric field.

$$V = \frac{W}{q}$$

Since work is measured in joule and charge in coulomb, therefore electric potential is measured in joule per coulomb (**J/C**). This unit occurs so often in our study of electricity, so it has been named as volt, in honour of the scientist Alessandra Volta (the inventor of the voltaic cell).

$$1 \text{ Volt} = \frac{1 \text{ joule}}{1 \text{ coulomb}}$$

Potential is a scalar quantity, therefore it is added algebraically. For a positively charged body potential is positive and for a negatively charged body potential is negative.

6.2 (c) Electric Potential Difference :

Consider a charge Q placed at a point P . Let A and B be two other point (B being closer to A) as shown

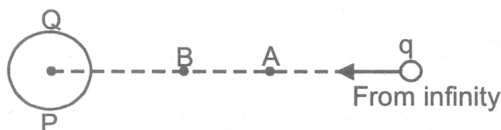

If a charge q is brought from infinity to A , a work W_A will be done.

The potential at A will then be, $V_A = \frac{W_A}{q}$

If charge q is brought from infinity to B , the work done will be W_B .

The potential at B will be, $V_B = \frac{W_B}{q}$

The quantity $V_B - V_A$ is called the potential difference between points A and B in the electric field of charge Q .

Mathematically we have,

$$V_B - V_A = \frac{W_B}{q} - \frac{W_A}{q}$$

Electric potential difference is also measured in volt.

6.3 ELECTRIC CURRENT :

The electric current is a flow of electric charges (called electrons) in a conductor. The magnitude of electric current in a conductor is the amount of electric charge passing through a given point of the conductor in one second. If a charge of Q coulombs flow through a conductor in time t seconds, then the magnitude of the electric current I flowing through it is given by :

$$I = \frac{Q}{t}$$

The unit of charge, in S.I. system is coulomb, which is equivalent to the charge of nearly 6.25×10^{18} electrons.

If charge is measured in coulomb, then the flow of 1 coulomb/second gives us the unit of current, which is called ampere named in the honour French scientist, Andre - Marie Ampere (1775 - 1836).

Definition of ampere :

When 1 coulomb of charge flows through any cross - section of a conductor 1 second, the electric current flowing through it, is said to be 1 ampere.

$$1 \text{ mA} = \frac{1}{1000} \text{ A}$$

Current is measured by an instrument called ammeter. The ammeter is connected in series with the circuit through which the current is to be measured. An ammeter should have very low resistance.

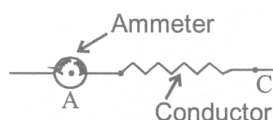

6.3 (a) Direction of Electric Current :

When electricity was invented a long time back, it was known that there are two types of charges : positive charges and negative charges, but the electron had not been discovered at that time. So, electric current was considered to be a flow of positive charges and the direction of flow of the positive charges was taken to be the direction of electric current. Thus, the conventional direction of electric current is from positive terminal of a cell (or battery) to the negative terminal through the circuit.

6.3 (b) How the Current Flows in a Wire :

As electric current is the flow of electrons in a metal wire (or conductor) when a cell or battery is connected across its ends. A metal wire has plenty of free electrons in it. When the metal wire has not been connected to a source of electricity like a cell or a battery, then the electrons present in it move at random in all the directions between the atoms of the metal wire as shown in figure below.

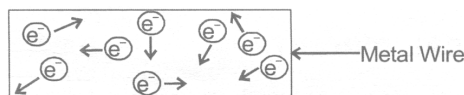

When a source of electricity like a cell or a battery is connected between the ends of the metal wire, then an electric force acts on the electrons present in the wire. Since the electrons are negatively charged, they start moving from the negative end to the positive end of the wire and this flow of electrons constitutes the electric current in the wire.

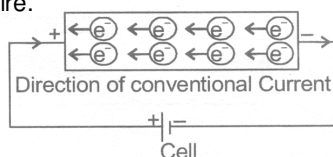

6.3 (c) How to get a Continuous flow of Electric Current :

It is due to the potential difference two points that an electric current flows between them. The simplest way to maintain a potential difference between the two ends of a conductor so as to get a continuous flow of current is to connect the conductor between the terminals of a cell or a battery. Due to the chemical reactions going on inside the cell or battery, a potential difference is maintained between its terminals and this potential difference drives the current in a circuit.

6.4 ELECTRICAL SYMBOLS :

The various electrical symbols used in electric circuits are given below :

(i) Cell	
(ii) Battery	
(iii) Connecting wire	
(vi) A wire joint	
(v) Wire crossing without contact	
(vi) Fixed resistance (or Resistor)	
(vii) Variable resistance (or Rheostat)	
(viii) Ammeter	
(ix) Voltmeter	
(x) Galvanometer	
(xi) An open switch (An open plug key)	
(xii) A closed switch (A closed plug key)	
(xiii) Electric bulb	

6.4 ELECTRICAL CIRCUITS :

A continuous path consisting of conducting wires and other resistances (like lamps, bulbs etc.) between the terminal of a battery, along which an electric current flows, is called a circuit.

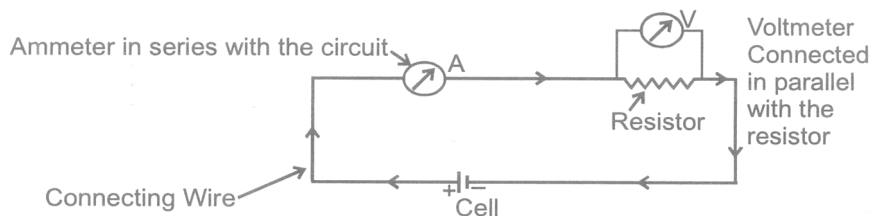

6.4 (a) Open Electric Circuit :

An electric circuit through which no electric current flows is known as open electric circuit. The electric circuit will be open circuit if the plug of the key is taken out or if the connecting wire break from any point.

6.4 (b) Closed Circuit :

An electric circuit through which electric current flows continuously is known as closed circuit.

DAILY PRACTICE PROBLEMS # 6

OBJECTIVE DPP - 6.1

1. How many electrons constitute a current of
 (A) 6.25×10^{18} (B) 6.25×10^{12} (C) 6.25×10^{11} (D) 6.25

2. 1 Coulomb is equal to :
 (A) 1 amp \times 1 sec (B) 1 amp / 1 sec (C) 1 joule \times 1 amp (D) 1 joule / 1 sec

3. When a body is negatively charged by fraction, it means :
 (A) the body has acquired excess of electrons (B) the body has acquired excess of protons
 (C) must be zero (D) many be negative or positive or zero

4. If a charged body attracts another body, the charge on the other body :
 (A) must be negative (B) must be positive
 (C) must be zero (D) may negative or positive or zero

5. A suitable unit for expressing the strength of electric field is :
 (A) V/C (B) C/m (C) N/C (D) C/N

6. One ampere equal :
 (A) $10^6 \mu A$ (B) $10^{-6} \mu A$ (C) $10^{-3} \mu A$ (D) 10 mA

7. What constituted current in a metal wire ?
 (A) Electrons (B) Protons (C) Atoms (D) Molecules

8. If I is the current through a wire and e is the charge of electron, then the number of electrons in t seconds will be given by-
 (A) $\frac{Ie}{t}$ (B) e/It (C) It/e (D) Ite

9. Conventionally, the direction of the current is taken as -
 (A) the direction of flow of negative charges (B) the direction of flow of atoms
 (C) the direction of flow of positive charges (D) the direction of flow of molecules

10. Figure shows, current in a part of electrical circuit, then the value of current is -

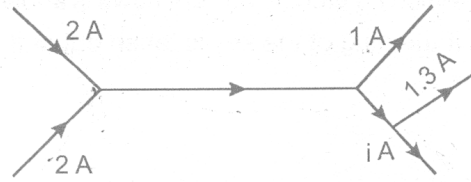

- (A) 1.7 A (B) 3.7 A (C) 13 A (D) 1.0 A

SUBJECTIVE DPP - 6.2

1. What is conventional current ?
2. A wire is carrying current. is it charged ? If yes then, why ?
3. One coulomb of charge flows through any cross section of a conductor in 1 second. What is the current flowing through the conductor ?
4. Which of the two is connected in series, ammeter or voltmeter ?
5. What is the potential difference between the terminals of battery is 250 joules of work is required to transfer 20 coulombs of charge from one terminal of the battery to the other ?

ELECTRICITY

PL - 7

7.1 ELECTRICAL RESISTANCE :

7.1 (a) Ohm's Law :

It states that the current passing through a conductor is directly proportional to the potential difference across its ends, provided the temperature and other physical conditions (mechanical strain etc.), remain unchanged i.e.,

Where R is a content called resistance of the conductor.

The relation $R = V/I$ is referred to an Ohm's law, after the German physicist George Simon Ohm (1789 - 1854), who discovered it.

It is quite clear from the above equation that

- (i) The current I is proportional to the potential difference V between the ends of the resistor.
- (ii) Current I is inversely proportional to the resistance.

Experimental verification of ohm's law :

Set up a circuit as shown in the figure below consisting of a wire AB, a current measuring instrument called ammeter, an instrument measuring the potential difference called voltmeter and a number of cells, each of which provided some constant potential difference across the two point of a conductor. First, use one cell and note the current in the circuit and the potential difference across the wire AB. Suppose potential difference due to the cell produces a current I in the circuit and a potential difference (V) across the wire AB. Repeat this experiment with two cells, three cells and four cells.

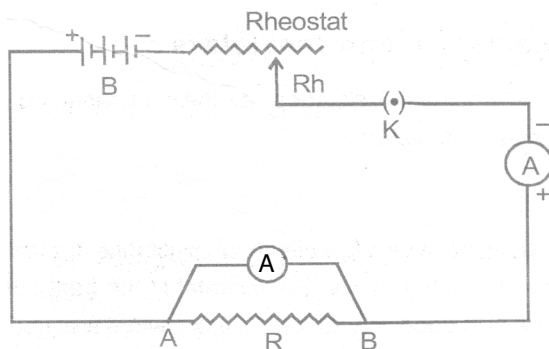

Note the successive readings in the ammeter and the voltmeter. WE will find that with two cells in the circuit, the current would be **2I** and the potential difference **2v**. Similarly, with three cells the current is **3I** and potential difference **3v** and so on. [The important precaution to observe here is not allow the current of flow in the wire continuously. This can be done by taking off the plug key and closing it only when the current is to be drawn.]

Now, plot a graph between the current and the potential difference. we will be a straight line graph.

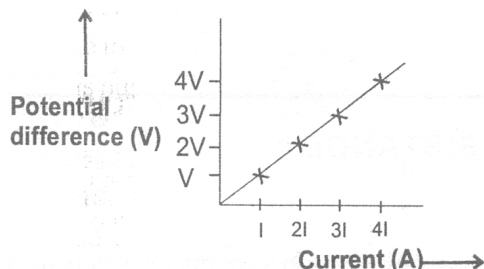

7.1 (b) Resistance of a Conductor :

The electric current is a flow of electrons through a conductor. When the electrons move from one part of the conductor to the other part, they collide with other electrons and with the atoms and ions present in the body of the conductor. Due to these collisions, there is some obstruction or opposition to the flow of electrons through the conductor.

The property of a conductor due to which it opposes the flow of current through it, is called resistance. The resistance of conductor is numerically equal to the ratio of potential difference across its ends to the current following through it.

$$\Rightarrow \text{Resistance} = \frac{\text{Potential difference}}{\text{Current}}$$

$$\text{Or } R = \frac{V}{I}$$

7.1 (c) Unit of Resistance :

The S.I. unit of resistance is **ohm**, which is denoted by the symbol Ω .

When a potential difference of 1 volt is applied to its ends and a current of 1 ampere flows through it, then resistance of the conductor will be 1 ohm.

7.1 (d) Conductors, Resistors and Insulators :

On the basis of their electrical resistance, all the substances can be divided into three groups: conductors, resistors and insulators.

(i) Conductors :

Those substances which have very low electrical resistance are called conductors. A conductor allows the electricity to flow through it easily. Silver metal is the best conductor of electricity. Copper and aluminum metals are also conductors. Electric wires are made of copper or aluminum because they have very low electrical resistance.

(ii) Resistor :

Those substances which have comparatively high electrical resistance, are called resistors. The alloys like nichrome, manganin and constantan (or ureka), all have quite high resistances, so they are used to make those electrical devices where high resistance is required. A resistor reduces the current in the circuit.

(iii) Insulators :

Those substances which have infinitely high electrical resistance are called insulators. An insulator does not allow electricity to flow through it. Rubber is an excellent insulator. Electricians wear rubber handgloves while working with electricity because rubber is an insulator and protects them from electric shocks. Wood is also a good insulator.

7.1 (e) Factors affecting the Resistance of a Conductor :

Resistance depends upon the following factors :

- (i) length of the conductor.
- (ii) Area of cross - section of the conductor (or thickness of the conductor).
- (iii) Nature of the material of the conductor.
- (iv) Temperature of the conductor,

Mathematically : it has been found by experiments that :

(i) The resistance of a given conductor is directly proportional to its length i.e.

$$R \propto \ell \quad \dots\dots\dots(i)$$

(ii) The resistance of a given conductor is inversely proportional to its area of cross-section i.e.

$$R \propto \frac{\ell}{A} \quad \dots\dots\dots(ii)$$

From (i) and (ii)

$$R \propto \frac{\ell}{A}$$

$$R = \frac{\rho \times \ell}{A} \quad \dots\dots\dots(iii)$$

Where ρ (rho) is a constant known as resistivity of the material of the conductor. Resistivity is also known as specific resistance.

Dependency of resistance on temperature :

If R_0 is the resistance of the conductor at 0°C and R_t is the resistance of the conductor at $t^\circ\text{C}$ then the relation between R_0 and R_t is given by.

$$R_t = R_0 (1 + \alpha \Delta T) \quad \text{[Here } \Delta t = t - 0 = t \text{]}$$

or
$$\alpha = \frac{R_t R_0}{R_0 t}$$

Here, α = Coefficient of Resistivity, t = temperature in $^\circ\text{C}$

7.1 (r) Resistivity :

$$\text{Resistivity, } \rho = \frac{R \times A}{\ell} \quad \dots\dots\dots(\text{iv})$$

By using this formula, we will now obtain the definition of resistivity. Let us take a conductor having a unit area of cross - section of 1 m^2 and a unit length of 1 m . So, putting $A = 1$ and $\ell = 1$ in equation (iv), we get:
Resistivity, $\rho = R$

The resistivity of a substance is numerically equal to the resistance of a rod of the substance which is 1 metre long and 1 metre square in cross - section.

$$\rho = \frac{\text{ohm} \times (\text{metre})^2}{\text{metre}} = \text{ohm - metre}$$

The S.I. unit of resistivity is ohm-metre which is written in symbols as $\Omega \cdot \text{m}$.

Resistivity of a substance does not depend on its length or thickness. It depends only on the nature of the substance. The resistivity of a substance is its characteristic property. So, we can use the resistivity values to compare the resistances of two or more substances.

(i) Importance of resistivity :

A good conductor of electricity should have a low resistivity and a poor conductor of electricity should have a high resistivity. The resistivities of alloys are much more higher than those of the pure metals. It is due to their high resistivities that manganin and constantan alloys are used to make resistance wires used in electronic appliances to reduced the current in an electrical circuit.

Nichrome alloy is used for making the heating elements of electrical appliances like electric irons, room-heaters, water-heaters and toasters etc. because it has very high resistivity and it does not undergo oxidation (or burn) even when red-hot.

(ii) Effect of temperature of resistivity :

The resistivity of conductors (like metals) is very low. The resistivity of most of the metals increases with temperature. On the other hand, the resistivity of insulators like ebonite, glass and diamond is very high and does to changes with temperature. The resistivity of semi-conductors like silicon and germanium is in between those of conductors and insulators and decreases on increasing the temperature. Semi-conductors are proving to be of great practical importance because of their marked change in conducting properties with temperature and impurity concentration.

Que.: Why alloys do not oxidize (burn) readily at high temperature ?

Ans. Because with the change in temperature their resistivity changes less rapidly.

7.1 (g) Combination of Resistances (or Resistors) :

Apart from potential difference, current in circuit depend or resistance of the circuit. So, in the electrical circuits of radio, television and other similar things, it is usually necessary to combine two or more resistances to get the required current in the circuit. We can combine the resistances lengthwise (called series) or we can put the resistances parallel to one another. Thus, the resistances can be combined in two ways : (i) series combination (ii) parallel combination

(i) Series combination of resistors :

Consider three resistors of resistances R_1 , R_2 and R_3 connected in series to cell of potential difference V as shown in figure. Since the three resistors are connected in series therefore the current I through each of them is same.

Then by Ohm's law the potential drop across each resistor is given by $V_1 = IR_1$, V_2 and $V_3 = IR_3$.

Since V is the total potential in the circuit therefore by conservation of energy we have

$$V = V_1 + V_2 + V_3$$

Substituting for V_1 , V_2 and V_3 in above equation we have,

$$V = IR_1 + IR_2 + IR_3 \quad \dots\dots\dots (i)$$

If R_s is the equivalent resistance of the series combination, then by Ohm's law we have

$$V = IR_s \quad \dots\dots\dots (ii)$$

Therefore from equations (i) and (ii) we have

$$IR_s = IR_1 + IR_2 + IR_3$$

Hence

$$R_s = R_1 + R_2 + R_3$$

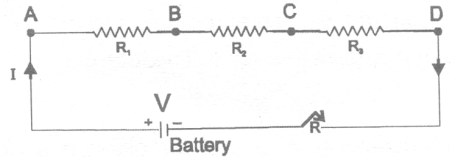

Series combination of resistances

Thus in series combination the equivalent resistance is the sum of the individual resistances. For more resistors, the above expression would have been-

$$R_s = R_1 + R_2 + R_3 + \dots\dots\dots$$

NOTE :

In a circuit, if the resistors are connected in series :

- (A) The current is same in each resistor of the circuit :
- (B) The resistance of the combination of resistors is equal to sum of the individual resistors.
- (C) The total voltage across the combination is equal to the sum of the voltage drop across the individual resistors.
- (D) The equivalent resistance is greater than that of any individual resistance in the series combination.

(ii) Parallel combination of resistors :

Consider two resistors R_1 and R_2 connected in parallel as shown in figure. When the current I reached point 'a', it splits into two parts I_1 going through R_1 and I_2 going through R_2 . If R_1 is greater than R_2 , then I_1 will be less than I_2 i.e. the current will tend to take the path of least resistance.

Since charge must be conserved, therefore the current I that enters point 'a' must be equal to the current that leaves that point. Therefore we have

$$I = I_1 + I_2 \quad \dots\dots\dots(i)$$

Since the resistors are connected in parallel therefore the potential across each must be same, hence by Ohm's law we have

$$I_1 = \frac{V}{R_1} \text{ and } I_2 = \frac{V}{R_2} \text{ substituting in equation (i) we have,}$$

$$I = \frac{V}{R_1 + \frac{V}{R_2}} \quad \dots\dots\dots(ii)$$

Let R_p be the equivalent resistance of the parallel combination, then by Ohm's law we have,

$$I = \frac{V}{R_p} \quad \dots\dots\dots(iii)$$

Hence from equations (ii) and (iii) we have,

$$\frac{V}{R_p} = \frac{V}{R_1} + \frac{V}{R_2} \quad \text{or} \quad \frac{1}{R_p} = \frac{1}{R_1} + \frac{1}{R_2}$$

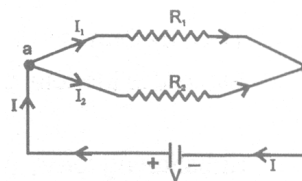

An extension of this analysis to three or more resistors in parallel gives the following general expression

$$\frac{1}{R_p} = \frac{1}{R_1} + \frac{1}{R_2} + \frac{1}{R_3} + \dots$$

NOTE :

(A) The sum of the reciprocals of the individual resistance is equal to the reciprocal of equivalent resistance, R_p .

(B) The currents in various resistors are inversely proportional to the resistances, higher the resistance of a branch, the lower will be the current through it. The total current is the sum of the currents flowing in the different branches.

(C) The voltage across each resistor of a parallel combination is the same and is also equal to the voltage across the whole group considered as unit.

NOTE : For n equal resistances $\frac{R_s}{R_p} = n^2$

DIALY PRACTICE PROBLEMS # 7

OBJECTIVE DPP - 7.1

1. When the temperature of metallic conductor is increased its resistance :
 (A) always decrease (B) always increase
 (C) may increase or decrease (D) remain the same
2. Specific resistance of a wire depends upon :
 (A) its length (B) its cross-sectional area
 (C) its dimensions (D) its material
3. The unit of resistivity is :
 (A) ohm (B) ohm meter (C) ohm metre⁻¹ (D) mho metre⁻¹
4. A wire of resistance R is cut into n equal parts. These parts are then connected in parallel. The equivalent resistance of combination will be :
 (A) nR (B) R/n (C) n/R (D) R/n^2
5. A piece of wire of resistance $4\ \Omega$ is bent through 180° at its mid point and the two halves are twisted together, then resistance is :
 (A) $1\ \Omega$ (B) $2\ \Omega$ (C) $5\ \Omega$ (D) $8\ \Omega$
6. Three resistances each of $8\ \Omega$ are connected to a triangle. The resistance between any two terminals will be:
 (A) $12\ \Omega$ (B) $2\ \Omega$ (C) $6\ \Omega$ (D) $\frac{16}{3}\ \Omega$

7. In how many parts(equal) a wire of $100\ \Omega$ be cut so that a resistance of $1\ \Omega$ is obtained by connecting them in parallel ?
 (A) 10 (B) 5 (C) 100 (D) 50
8. The filament of an electric bulb is made of tungsten because :
 (A) its resistance is negligible (B) it is cheaper
 (C) its melting point is high (D) its filament is easily made
9. If a wire of resistance $1\ \Omega$ is stretched to double its length, then the resistance will become :
 (A) $\frac{1}{2}\ \Omega$ (B) $2\ \Omega$ (C) $\frac{1}{4}\ \Omega$ (D) $4\ \Omega$
10. In the given circuit, the effective resistance between points A and C will be :

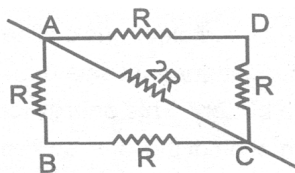

- (A) $\frac{3}{2}R$ (B) $6R$ (C) $\frac{2}{3}R$ (D) $3R$

SUBJECTIVE DPP - 7.2

- Does the value of resistance of a conductor depend upon the potential difference applied across it or the current passed through it ?
- A wire of resistivity ρ is stretched to double its length. What will be its new resistivity ?
- Two wires A and B of same metal have the same area of cross-section and have their lengths in the ratio 2 : 1. What will be the ratio of currents flowing through them, when the same potential difference is applied across length of each of them ?
- Compare the resistance of two wires of same material. Their lengths are in the ratio 2 : 3 and their diameters are in the ratio 1 : 2.
- If the current supplied to a variable resistor is constant, draw a graph between voltage and resistance.
- Calculate the potential difference across each resistor in the circuit shown in figure below.

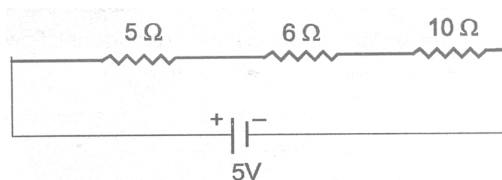

ELECTRICITY

8.1 HEATING EFFECT OF CURRENT :

When the ends of a conductor are connected to a battery, then free electrons move with drift velocity and electric current flows through the wire. These electrons collide continuously with the positive ions of the wire and thus the energy taken from the battery is dissipated. To maintain the electric current in the wire, energy is taken continuously from the battery. This energy is transferred to the ions of the wire by the electrons. This increases the thermal motion of the ions, as a result the temperature of the wire rises. The effect of electric current due to which heat is produced in a wire when current is passed through it is called heating effect of current or Joule heating. In 1841 Joule found that when current is passed through a conductor the heat produced across it is :

(i) Directly proportional to the square of the current through the conductor i.e. $H \propto I^2$

(ii) Directly proportional to the resistance of the conductor i.e. $H \propto R$

(iii) Directly proportional to the time for which the current is passed i.e. $H \propto t$

Combining the above three equations we have $H \propto I^2 R t$

$$\text{or } H = \frac{I^2 R t}{J}$$

Where J is called Joule's mechanical equivalent of heat and has a value of $J = 4.18 \text{ cal}^{-1}$. The above equation is called Joule's law of heating.

In some cases, heating is desirable, while in many cases, such as electric motors, generators or transformers, it is highly undesirable. Some of the devices in which heating effect of an electric current is desirable, are incandescent lamps, toasters, electric irons and stoves. The tungsten filament of an incandescent lamp operates at a temperature of 2700°C . Here, we see electrical energy being converted into both heat and light energy.

8.1 (a) Electric Energy :

The fact that conductors offer resistance to the flow of current, means that work must be continuously done to maintain the current. The role of resistance in electrical circuits is analogous to that of friction in mechanics. To calculate the amount of work done by a current I, flowing through a wire of resistance R, during the time t, the amount of work done is given by-

$$W = QV$$

but as $Q = I \times t$

therefore, the amount of work done, W is

$$W = V \times I \times t$$

By substituting the expression for V from Ohm's law,

$$V = IR$$

we finally get $W = I^2 Rt$

This shows that the electrical energy dissipated or consumes depends on the product of the square of the current I. flowing through the resistance R and the time t.

(i) Commercial unit of electrical energy (Kilowatt - hour) :

The S.I. unit of electrical energy is joule and we know that for commercial purposes we use a bigger unit of electrical energy which is called “kilowatt - hour”. One kilowatt - hour is the amount of electrical energy consumed when an electrical appliance having a power rating of 1 kilowatt and is used for 1 hour.

(ii) Relation between kilowatt hour and Joule :

Kilowatt-hour is the energy supplied by a rate of working of 1000 watts for 1 hour.

$$1 \text{ kilowatt-hour} = 3600000 \text{ joules}$$

$$\Rightarrow 1 \text{ kWh} = 3.3 \times 10^6 \text{ J}$$

8.1 (b) Electric Power :

The rate at which electric energy is dissipated or consumed, is termed as electric power. The power P is given by,

$$P = W/t = I^2 R$$

The unit of electric power is watt, which is the power consumed when 1 A of current flows at a potential difference of 1 V.

(i) Unit of power : The S.I. unit of electric power ‘watt’ which is denoted by the letter W. The power of 1 watt is a rate of working of 1 joule per second.

A bigger unit of electric power is kilowatt.

$$1 \text{ kilowatt (kW)} = 1000 \text{ watt.}$$

Power of an agent is also expressed in horse power (hp).

$$1 \text{ hp} = 746 \text{ watt.}$$

(ii) Formula for calculating electric power :

$$\begin{aligned} \text{We know,} & \quad \text{Power, } P = \frac{\text{Work}}{\text{Time}} \\ \text{and} & \quad \text{Work, } W = V \times I \times t \text{ joules} \\ \therefore & \quad P = \frac{V \times I \times t}{t} \\ & \quad P = V \times I \\ & \quad P = V \times I \end{aligned}$$

Power P in terms of I and R :

$$\text{Now from Ohm's law we have } \frac{V}{I} = R$$

$$\begin{aligned} & \quad V = I \times R \\ & \quad P = I \times R \times I \\ \therefore & \quad P = I^2 \times R \end{aligned}$$

Power P in terms of V and R :

$$\begin{aligned} \text{We know,} & \quad P = V \times I \\ \text{From Ohm's low} & \quad I = \frac{V}{R} \\ & \quad P = V \times \frac{V}{R} \end{aligned}$$

$$P = \frac{V^2}{R}$$

8.1 (c) Power - Voltage Rating of Electrical Appliances :

Every electrical appliance like an electric bulb, radio or fan has a label or engraved plate on it which tells us the voltage (to be applied) and the electrical power consumed by it. For example, if we look at a particular bulb in our home it may have the figures **220 V, 100W** written on it. Now **220 V** means that this bulb is to be used on a voltage of **220 volts** and **100 W** Which means it has a power consumption of 100 watts or 100 joules per second.

8.1 (d) Application of Heating Effect of Current :

Domestic electric appliances such as electric bulb, electric iron geyser, room heater etc work on heating effect of current and are rated in terms of voltage and wattage. The coils of these devices are made of a material of a very high resistance, (for instance, nichrome or tungsten) such that when a current passes through the coil, heat is generated. Generally the potential difference applied to the electrical appliance is the same as the of the mains i.e. **220-230 V** in India an **110 V** is U.S.A. Canada etc.

8.1 (e) Electric Fuse :

An electric fuse is an easily fusible wire of short length put into an electric circuit for protection purpose. It is arranged to melt ("blow") at a definite current. It is an alloy of lead and tin (**37% lead + 63% tin**). It has a low resistivity and low melting point. As soon as the safe limit of current exceeds, the fuse "blows" and the electric circuit is cut off.

Consider a wire of length **L**, radius **r** and resistivity **p**. Let **I** be the current flowing through the wire. Now rate at which heat is produced in the wire.

$$P = I^2 R = \frac{I^2 \rho L}{\pi r^2} \quad \left[\because \frac{\rho L}{A} = \frac{\rho}{\pi r^2} \right]$$

This heat increases the temperature of the wire. Due to radiation some heat is lost. The temperature of the fuse becomes constant when the heat lost due to the radiation becomes equal to the heat produced due to the passage of current. This gives the value of current which can safely pass through the fuse. In other words we have,

$$I \propto r^{3/2}$$

Illustration :

1. 15 bulbs of 60W each, run for 6 hours daily and a refrigerator of 300 W runs for 5 hours daily. Work out per day bill at 3 rupees per unit.

Sol. Total wattage of 15 bulbs = 15 × 60 W = 900 W
 \therefore Electrical energy consumed by bulbs per day = $P \times t = 900 \times 6 = 5400$ Wh
 And electrical energy consumed by refrigerator per day = $300 \times 5 = 1500$ Wh
 Total electrical energy consumed per day = $(5400 + 1500)$ Wh = 6900 Wh

$$\therefore \text{Electrical energy consumed per day} = \frac{6900}{1000} \text{ kWh} = 6.9 \text{ kWh}$$

Here, per day bill = Rs. 6.9×3 = Rs. 20.7

2. Two lamps, one rated 100 W at 220 V and other 60 W at 220 V are connected in parallel to a 220 V supply. What is current drawn from the supply line ?

Sol. Given that

$$V = 220 \text{ V}$$

$$P_1 = 100 \text{ W and } P_2 = 60 \text{ W}$$

$$\therefore \text{Current } I_1 = \frac{P_1}{V} = \frac{100}{220} = \frac{5}{11} \text{ A}$$

Similarly,

$$\text{Current } I_2 = \frac{P_2}{V} = \frac{60}{220} = \frac{3}{11} \text{ A}$$

$$\text{Hence, total current drawn from the supply line} = \frac{5}{11} + \frac{3}{11} = \frac{8}{11} \text{ A} = 0.727 \text{ A.}$$

DAILY PRACTICE PROBLEMS

OBJECTIVE DPP - 8.1

- Rate of heat generated by electrical current in a resistive circuit is expressed in :
(A) IR (B) IR² (C) I²R (D) \sqrt{IR}
- Two heater wires of equal length are first connected in series and then in parallel with a battery. Their ratio of heat produced in the two cases is :
(A) 2 : 1 (B) 1 : 2 (C) 4 : 1 (D) 1 : 4
- How much electrical energy in kilowatt hour is consumed in operating ten, 50 watt bulbs for 10 hours per day in a month of 30 days ?
(A) 15 (B) 150 (C) 1500 (D) 15000
- An electric iron draws a current of 4A when connected to a 220 V mains. Its resistance must be :
(A) 40 Ω (B) 55 Ω (C) 100 Ω (D) None of these
- The resistance of a conductor is reduced to half its initial value. In doing so the heating effects in the conductor will become :
(A) half (B) one-fourth (C) four times (D) double
- Laws of heating are given by :
(A) Faraday (B) Joule (C) Ohm (D) Maxwell
- An electric iron is based upon the principle of :
(A) magnetic effect of current (B) heating effect of current
(C) chemical effect of current (D) none of these

8. A fuse wire is always connected to the :
(A) neutral wire (B) earth wire (C) live wire (D) none of these
9. Heating effect of a current conductor is due to :
(A) Loss of kinetic energy of moving atoms (B) Loss of kinetic energy of moving electrons
(C) Attraction between electrons and atoms (D) Repulsion between electrons and atoms
10. The correct relation between heat produced (H) and electric current flowing is :
(A) $H \propto I$ (B) $H \propto \frac{1}{I}$ (C) $H \propto I^2$ (D) $H \propto \frac{1}{I^2}$

SUBJECTIVE DPP - 8.2

1. An electric kettle is rated 500 W, 220 V. It is used to heat 400 g of water for 30 seconds. Assuming the voltage to be 220 V, calculate the rise in the temperature of the water. Specific heat capacity of water = 4200 J/kg°C.
2. Three identical bulbs are connected in parallel with a battery. The current drawn from the battery is 6 A. If one of the bulbs gets fused, what will be the total current drawn from the battery ?
3. When two resistors are joined in series, the equivalent resistance is 90 Ω. When the same resistors are joined in parallel, the equivalent resistance is 20 Ω. Calculate the resistances of the two resistors.
4. Name a few practical applications of the heating effect of current.
5. Out of the following bulbs rated 40 W, 220 V, 60 W, 220 V and 100 W, 220 V which one will glow the brightest when connected in series to a supply of 220 V ?

ELECTRICITY

PL - 9

9.1 HOUSE - HOLD ELECTRICAL CIRCUIT :

Electric power is usually generated at places which are very far from the places where it is consumed. At the generating station, the electric power is generated at 11,000 volt (because voltage higher than this causes insulation difficulties, while the voltage lower than this involves high current). This voltage is alternating of frequency 50 Hz (i.e. changing its polarity 50 times in a second). The power is transmitted over long distances at high voltage to minimize the loss of energy in the transmission line wires. For a given electric power, the current becomes low at a high voltage and therefore the loss of energy due to heating ($=I^2 R t$) becomes less. Thus, the alternating voltage is stepped up from 11 kV to 132 kV at the generating station (or called grid sub-station). It is then transmitted to the main sub-station. At the main sub-station, this voltage is stepped down to 33 kV and is transmitted to the switching transformer station or the city sub-station. At the city sub-station, it is further stepped down to 220 V for supply to the consumer as shown in figure.

To supply power to a house either the overhead wires on poles are used or an underground cable is used. Before the electric line is connected to the meter in a house, a fuse of high rating (≈ 50 A) is connected at the pole or before the meter. This is called the company fuse. The cable used for connection has three wires : (i) live (or phase) wire, (ii) neutral wire and (iii) earth wire. The neutral and the earth wire are connected together at the local sub-station, so the neutral wire is at the earth potential. After the company fuse, the cable is connected to a kWh meter. From the meter, connections are made to the distribution board through a main fuse and a main switch.

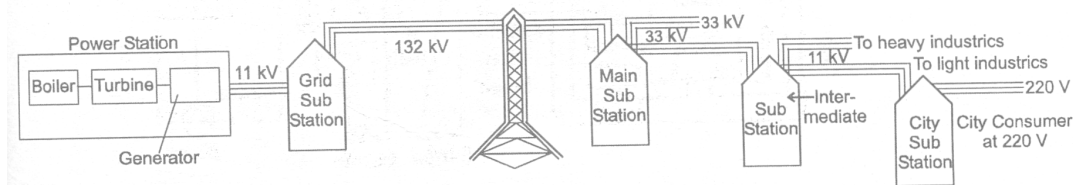

The main switch is a double pole switch. it has iron covering. The covering is earthed. This switch is used to cut the connections of the live as well as the neutral wires simultaneously. The main switch and the meter are locally earthed (in the compound of house). From the distribution board, the wires go to the different parts of the house.

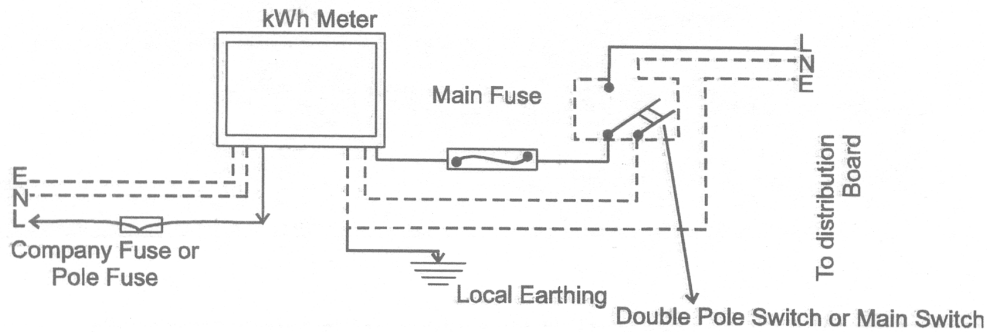

There are two systems of wiring which are in common use :

- (i) the tree system (ii) the ring system

9.1 (a) Tree System :

In this system different branch lines are taken from the distribution board for the different parts of the house. These branch lines look like the different branches of a tree. Each branch line is taken to a room through a fuse in the live wire. The different circuits are connected in parallel so that if there is a short circuiting in one distribution circuit, its fuse will blow off, without affecting the electric supply in the other circuits. The neutral N and the earth E are common for all circuits. The connection to the neutral N is to complete the circuit. All the appliances in a room are connected in parallel so that they work at the same voltage. The line wires used for connections should be of proper current carrying capacity depending on the rating of the appliance to avoid their overheating. The overheating in line often results in fire. The switches and sockets should also have the proper current carrying capacity.

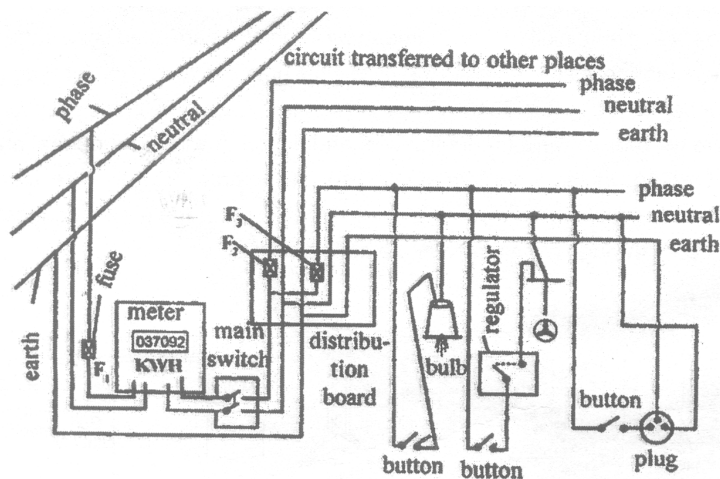

Disadvantages :

- (i) It requires plugs and sockets of different sizes for different current carrying capacities.
- (ii) When the fuse in one distribution line blows, it disconnects all the appliances in the distribution line.
- (iii) This wiring is expensive.
- (iv) If a new appliance is to be installed requiring higher current say 15 A, while the original circuit in the room is for 5 A rating, then it is necessary to put new leads upto the distribution box. This could be quite expensive and inconvenient.

9.1 (b) Ring System :

The ring-system of electric wiring is now rapidly replacing the older tree system described above. It consists of a ring-circuit. Wires starting from the main fuse-box, run around all the main rooms of the house and then come back to the fuse-box again. The fuse box contains a fuse of rating about 30A. A separate connection is taken from the live wire of the ring for each appliance. The terminal of the appliance is connected to the live wire through a separate fuse and a switch. If the fuse of one appliance burns, it does not affect the other appliances. For each appliance, the wires used for connection should be of proper carrying capacity.

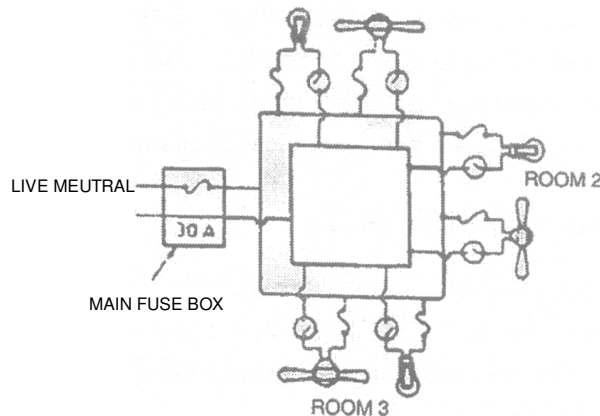

The ring system of wiring

Advantages :

It can be noted that the current can travel to an individual appliance through two separate paths. Thus effectively the connection for each appliance is through double thickness of wire. Therefore the wire used for ring main is of a lower rating than that would be required for a direct connection to the mains. This reduces the cost of wiring considerably. Plugs and sockets of the same size can be used. Another advantage of this system is in installing a new appliance, since a new line up to the distribution box is not required. The appliance can be directly connected to ring main in the room. The only consideration is that the total load on the ring circuit should not exceed the main fuse viz. 30 A.

9.1 (c) Domestic Heating Applications :

Electric appliances like iron, heater radiator etc. depend on the fact that when a current is sent through a wire, the wire is heated up and it begins to radiate energy.

The most widely used material for making the heater wire is nichrome. It is an alloy of nickel and chromium in the ratio of 4 : 1. It is chosen because of the following reasons :

- (i) It has high resistivity. A nichrome wire of ordinary length shows sufficient resistance.
- (ii) It can withstand high temperature without oxidation.
- (iii) Its melting point is very high.

9.1 (d) Hazards of Electricity :

We have seen earlier that touching a bare electricity wire with current flowing through it can give a dangerous electric shock. This is because electricity then flows through the body and damages the cells. The amount of damage caused depends on the magnitude of current and the duration for which it flows in the body. The magnitude of current increases if the body is wet. That is why we are always advised not to touch any electrical appliances or a switch with wet hands.

A severe electric shock affects the muscles. Sometimes the shock may be so severe that the person may not be able to use his muscle to pull his hand away from the wire. In extreme cases, the heart muscles may get affected and may even lead to death.

9.2 EARTHING :

Earthing means to connect the metal case of electrical appliance to the earth (at zero potential) by means of a metal wire called "earth wire". In household circuits, we have three wires, the live wire, the neutral wire and the earth wire. In household circuits, we have three wires, the live wire, the neutral wire and the earth wire. One end of the earth wire is buried in the earth. We connect the earth wire to the metal case of the electrical appliance by using a three-pin plug. The metal casing of the appliance will now always remain at the zero potential of the earth. We say that the appliance has been earthed or grounded.

If, by chance, the live wire touches the metal case of the electric iron (or any other appliance) which has been earthed, then the current passes directly to the earth through the earth wire. It does not need our body to pass the current and therefore, we do not get an electric shock. Actually, a very heavy current flows through the earth wire and the fuse of household wiring blows out or melts. And it cuts off the power supply. In this way, earthing also saves the electrical appliance from damage due to excessive current.

9.3 COLOUR CODING OF WIRES :

An electric appliance is provided with a three-core flexible cable. The insulation on the three wires is of different colours. The old convention is red for live, black for neutral and green for earth. The new international convention is brown for live, light blue for neutral and green (or yellow) for earth.

9.4 GALVANOMETER :

A galvanometer is an instrument that can detect the presence of a current in a circuit. The pointer remains at zero (the centre of the scale) for zero current flowing through it. It can deflect either to the left or to the right of the zero mark depending on the direction of current.

(i) Moving coil galvanometer (ii) Moving magnet galvanometer
it is used to make ammeter and voltmeter as follows :

9.4 (a) Ammeter :

Ammeter is an electrical instrument which measures the strength of current in 'ampere' in a circuit which is always connected in series in circuit so that total current (to be measured) may pass through it. The resistance of an ideal ammeter is zero (practically it should be minimum).

9.4 (b) Voltmeter :

It is an electrical instrument which measures the potential difference in 'volt' between two points of electric circuit. The only difference between ammeter and voltmeter is that ammeter has its negligible (approximately zero) resistance so that it may measure current of circuit passing through it more accurately giving the deflection accordingly, while the voltmeter passes negligible current through itself so that potential difference developed due to maximum current passing through circuit may be measured.

Voltmeter has very high resistance and the resistance of an ideal voltmeter is infinite.

A voltmeter is always connected in parallel.

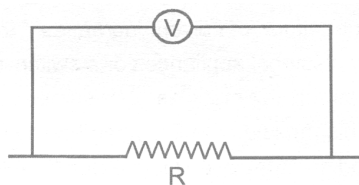

DAILY PRATICE PROBLEMS # 9

OBJECTIVE DPP-9.1

1. The wire having a red plastic covering is a :
(A) live wire (B) neutral wire (C) earth wire (D) none of these
2. A switch is always connected to the
(A) earth wire (B) neutral wire (C) live wire (D) none of these
3. The wire having a black plastic covering is a
(A) live wire (B) neutral wire (C) earth wire (D) none of these
4. The wire having a green plastic covering is a
(A) live wire (B) neutral wire (C) earth wire (D) none of these
5. In three pin socket (shoe) the bigger hole is connected to :
(A) any wire (B) live wire (C) neutral wire (D) earth wire
6. Coming of live wire and neutral wire in direct contact cause :
(A) short-circuiting (B) over loading
(C) no damage (D) unknown effect
7. In electric fitting in a house :
(A) the live wire goes through the switch (B) the neutral wire goes through the switch
(C) the earth wire goes through the switch (D) no wire goes through the switch
8. High power electrical appliances are earthed to
(A) avoid shock
(B) avoid wastage
(C) Make the appliance look beautiful
(D) reduce the bill

SUBJECTIVE DPP - 9.2

1. Name two types of wiring system done for domestic wirings.
2. Why is earthing important for electrical appliance ?
3. Which colour wire used for earthing or grounding ?
4. Explain earthing.

ANSWERS

(Objective DPP 6.1)

Q.	1	2	3	4	5	6	7	8	9	10
A.	A	A	A	D	C	A	A	C	C	A

(Subjective DPP 6.2)

2. No. 3. 1A 4. Ammeter 5. 12.5 volt

(Subjective DPP 7.2)

Q.	1	2	3	4	5	6	7	8	9	10
A.	B	D	B	D	A	D	A	C	D	C

3. 1 : 2 4. 8 : 3 6. $\frac{25}{1} \text{ V}, \frac{30}{21} \text{ V}, \frac{50}{21} \text{ V}$

(Subjective DPP 8.1)

Q.	1	2	3	4	5	6	7	8	9	10
A.	C	D	B	B	D	B	B	C	B	C

1. 8.9°C 2. 4A 3. 60 Ω, 30 Ω 5. 40W, 220V bulb will glow brightest.

(Objective DPP 9.1)

Q.	1	2	3	4	5	6	7	8
A.	A	C	B	C	D	A	A	A

MAGNETISM AND EMI

10.1 MAGNETIC EFFECT OF CURRENT :

Hans Oersted, in 1820, first discovered that when an electric current is passed through a conducting wire, a magnetic field is produced around it. If a compass needle is kept in the vicinity of the current carrying wire, the needle is found to deflect in a definite direction. If the direction of current in the wire is reversed, Then the direction of deflection of the needle is reversed.

AB is a wire lying in the north-south direction and connected to a battery through a rheostat and a tapping key. A compass needle is kept just below the wire. When the key is open i.e. no current is passed through the wire, the needle shows no deflection and points in the N-S direction (i.e. remains parallel to the wire) as shown in figure(a).

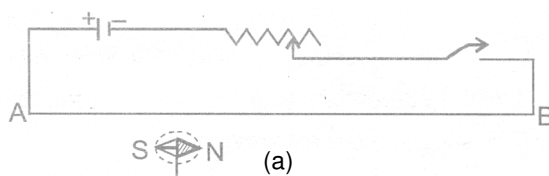

When the key is pressed and current passes in the wire in the direction A to B (i.e. from south to north and the north pole (**N**) of the needle deflects towards the west as figure (b). Thus a current (or moving charge) produces a magnetic field. When the direction of current in the wire is reversed by reversing the terminals of the batter, the north pole of the needle deflects towards the east as figure(c).

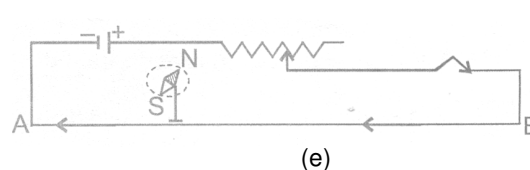
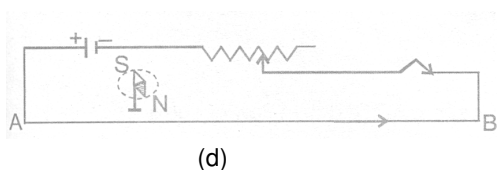
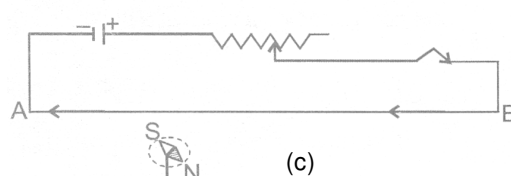
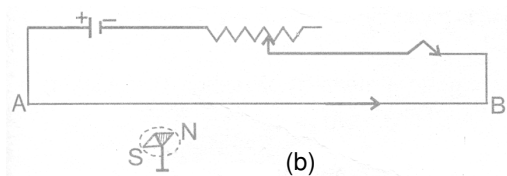

NOTE : If the compass needle is kept just above the wire, the deflection will be as shown in figure (d) and (e) for the direction (e) for the direction of current from A to B and from B to A respectively.

10.1 (a) Magnetic Field due to a Straight Current Carrying Wire :

When a current is passed through a conducting wire, a magnetic field is produced around it. The direction of magnetic field due to a straight current carrying wire can be mapped by means of a small compass needle or by iron fillings.

Take a sheet of smooth cardboard with a hole at the centre. Place it horizontally and pass a wire vertically through the hole, Sprinkle some iron fillings on the cardboard and pass an electric current through the wire. Gently tap the cardboard. We find that the iron filling arrange themselves in concentric circles around the wire as shown in figure.

If a small compass needle is kept anywhere on the board near the wire, the direction in which the north pole of the needle points gives the direction of the magnetic the magnetic field (i.e., magnetic lines of force) at that point.

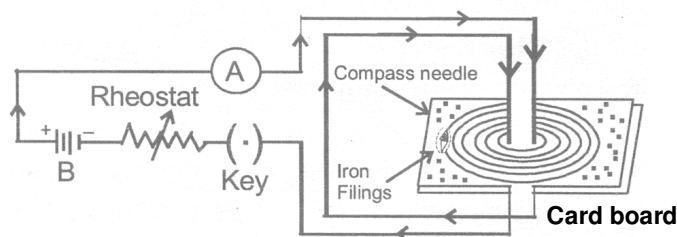

The magnetic lines of force form concentric circles near the wire, with their plane perpendicular to the straight conductor and with their centers lying on its axis. If the direction of current in the wire is reversed, the direction of lines of force is also reversed.

On increasing the strength of current in the wire, the lines of force become denser and iron filings are arranged in circles up to a larger distance from the wire, showing that the magnetic field strength has increased.

(i) Magnitude of magnetic field produced by a straight current-carrying conductor :

The magnitude of magnetic field (or strength of magnetic field) B produced by an infinitely long conductor in vacuum at a distance r from it, is given by :-

$$B = \frac{\mu_0 I}{2\pi r} \quad B = \text{Magnetic field strength} \quad \mu_0 = \text{Permeability of vacuum (a constant)}$$

I = Current (flowing in conductor) and

r = Distance from the conductor (where magnetic field is measured).

The unit of magnetic field B is tesla which is denoted by the symbol T (1 tesla is equal to 1 Newton per ampere per meter). Permeability of vacuum μ_0 is $4\pi \times 10^{-7}$ tesla metre per ampere.

(ii) Direction of magnetic field :

The direction of magnetic field (lines of force) produced due to flow of current can be known by the following rules :

(A) Maxwell's cork screw rule :

Imagine a right handed cork screw lying with its axis coincides with the current carrying wire. It is now rotated such that it advances in the direction of the current, the direction in which the screw rotates gives the direction for the magnetic lines of force.

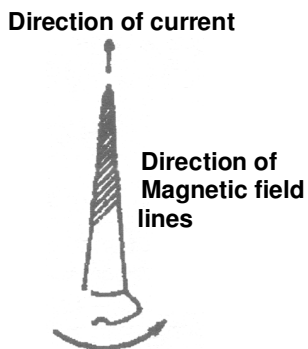

Maxwell's cork screw rule

(B) Right hand thumb rule :

If we hold the current carrying conductor in the right hand such that the thumb points in the direction of current, the fingers encircle the wire in the direction of magnetic lines of force.

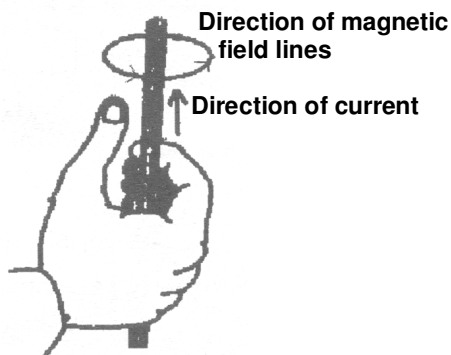

Right hand thumb rule

(C) Ampere's swimming rule :

Imagine a man swimming along the wire in the direction of current (such that the current enters at his feet and leaves him at his head) facing towards a magnetic needle kept underneath the wire, then the magnetic field produced in such that the north pole of the needle will be deflected towards his left

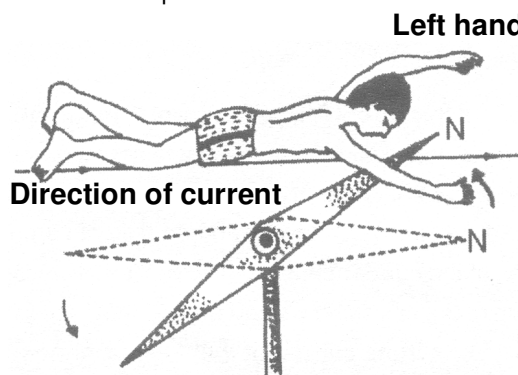

Ampere's Swimming Rule

10.1 (b) Magnetic Field due to Circular Coil Carrying Current :

A piece of wire bent in the form of a ring (or coil) is passed through a horizontal cardboard C at two points P and Q at the opposite ends of a diameter of the ring and then some iron fillings are scattered on the cardboard. The ends of the coil are connected to a battery through a rheostat and a key.

When a strong electric current is passed through the coil by closing the key and the cardboard is gently tapped we find that the iron filing arrange themselves in a definite pattern representing the magnetic lines of force due to the current carrying coil.

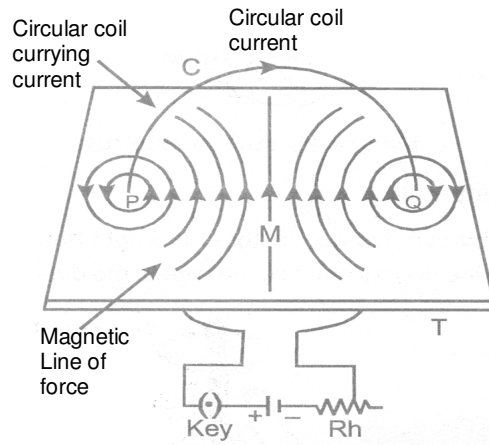

Direction of magnetic field is found by applying the right hand thumb rule to each section of the coil and we find that the concentric lines of force pass through the coil in the same direction. Further more that :

- (i) The magnetic lines of force are nearly circular near the wire.
- (ii) Within the space enclosed by the wire, the lines of force are in the same direction.
- (iii) Near the center of the coil, the lines of force are nearly parallel and the magnetic field may be assumed to be practically uniform for a small space around the centre.
- (iv) At the centre, the lines of force are along its axis and at right angle to the plane of the coil.
- (v) The magnetic field strength is increased if the number of turns in the coil is increased or the strength of current in the coil is increased.

Since the magnetic lines of force through the coil point in the same direction, hence one face of the coil acts as a large area of north polarity because it is sending out magnetic lines of force and the other face acts as a large area of south polarity as magnetic lines of force are entering it. thus, the coil has a magnetic field similar to a magnetised iron disc of same radius as that of the coil.

The polarity of the faces of the coil depends on the direction of current and is determined by the clock rule. Looking at the face of the coil, if the current around the face is in an anticlockwise direction, the face has north polarity, while if the current at that face is in the clockwise direction, the face has south polarity. This can be tested by using a compass needle.

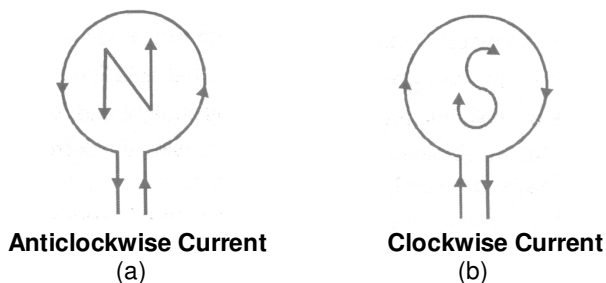

The magnitude of magnetic field **B** produced by a current-carrying circular wire at its centre is :
 (i) directly proportional to the current **I** passing through the circular wire and (ii) inversely proportional to the radius **r** of the circular wire.

i.e. $B \propto I$ and $B \propto \frac{1}{r}$

Magnetic field, $B = \frac{\mu_0 I}{2r}$

Formula which we have given above is applicable when there is only one turn of a circular wire. If we have circular coil having **N** turns of wire, then the magnetic field will become **N** times. Thus, the magnetic field at the centre of a circular coil of **N** turns having radius **r** and carrying current **I** is given by

$$B = \frac{N \times \mu_0 \times I}{2r}$$

Magnetic field produced by a circular coil carrying current is directly proportional to both, number of turn (**N**) and current (**I**), but inversely proportional to its radius (**r**). Thus, the strength of magnetic field produced by a current carrying circular coil can be increased by (i) increasing the number of turns of wire in the coil, (ii) increasing the current following through the coil and (iii) decreasing the radius of the coil.

10.1 (c) Magnetic Field due to a Solenoid Carrying Current :

If a conducting wire is wound in the form of a cylindrical coil whose diameter is less in comparison to the length, then this coil is called a solenoid (it looks like a helical spring). The magnetic field lines in a solenoid, through which current is passed, are as shown in figure.

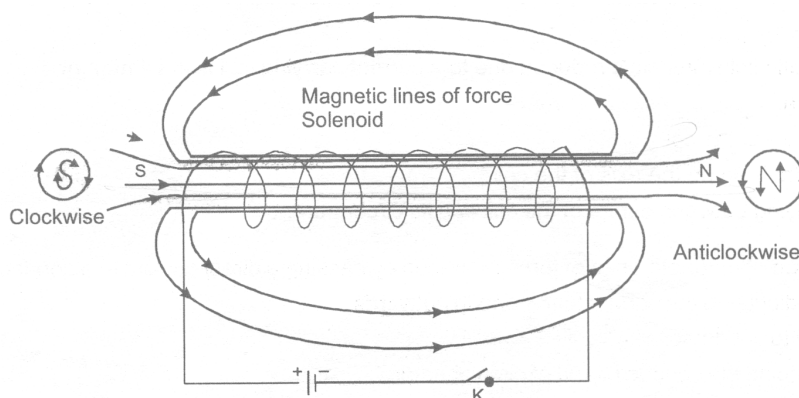

The magnetic field, thus produced, is very much similar to that of a bar magnet and one end of the coil acts like a magnetic north pole while the other acts like a south pole.
 The lines of force inside the solenoid are nearly straight and parallel to the axis of the solenoid.
 A strong magnetic field can be obtained by increasing the current strength.
 The magnetic field is increased if the number of turns in the solenoid of given length is increased.
 The magnetic field is also increased if soft iron core is kept along the axis of the solenoid.
 Thus a current carrying solenoid behaves like a bar magnet with fixed polarities at its ends.

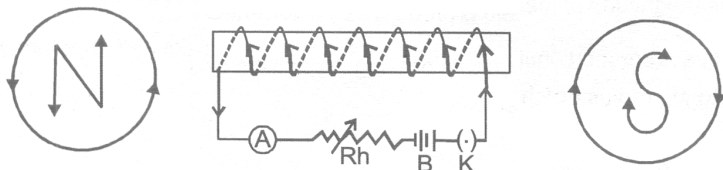

The strength of magnetic field produced by a current carrying solenoid depends upon :

(i) The number of turns in the solenoid : Larger the number of turns in the solenoid, greater will be the magnetic field produced.

(ii) The strength of current in the solenoid : Larger the current passed through solenoid, stronger will be the magnetic field produced.

(iii) The nature of “core material” used in making solenoid : The use of soft iron rod as core in a solenoid produced the strongest magnet.

Magnetic field inside the solenoid is :

$$B = \mu_0 n I \quad [\text{Here } n \text{ is number of turns per unit length}]$$

At the ends of the solenoid the magnetic field :

$$B_{\text{end}} = \frac{1}{2} \mu_0 n I$$

DAILY PRACTICE PROBLEMS

OBJECTIVE DPP – 10.1

- When a bar magnet is broken into two pieces :
 (A) we will have a single pole on each piece
 (B) each piece will have two unlike poles
 (C) each piece will have two like poles
 (D) None of these
- The magnetic field intensity produced due to a current carrying coil is maximum at :
 (A) any point
 (B) the centre of the coil
 (C) any point lying on the axis of the coil
 (D) points lying between centre of the coil and its circumference
- The direction of magnetic lines of force produced by passing a direct current in a conductor is :
 (A) perpendicular to the conductor & coming outwards
 (B) parallel to conductor
 (C) surrounding the conductor and of circular nature
 (D) perpendicular to the conductor & coming inwards

4. Which of the following statement is not correct about two parallel conductors carrying equal currents in the same direction ?
 (A) Each of the conductors will experience a force.
 (B) The two conductors will repel each other.
 (C) There are concentric lines of force around each conductor.
 (D) Each of the conductors will move if not prevented from doing so.
5. Which of the following determine the direction of magnetic field due to a current carrying conductor ?
 (A) Faraday's laws of electromagnetic induction. (B) Fleming's left-hand rule.
 (C) Lenz's law. (B) Maxwell's cork screw rule.
6. A cylindrical bar magnet is kept along the axis of a circular coil. If the magnet is rotated about its axis, then :
 (A) a current will be induced in the coil (B) no current will be induced in the coil.
 (C) only emf will be induced in the coil (D) an emf and current both will be induced in the coil
7. In the figure QR is a vertical conductor and the current I flows from R to Q. P is a point on the horizontal plane and is to the south of the wire. The direction of the magnetic field at P due to the current will be towards :

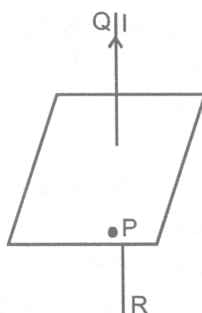

- (A) upward (B) north (C) east (D) west
8. A length of wire carries steady current. It is bent first to form a circular plane coil of one turn. The same length is now bent to give a double loop of smaller radius. The magnetic field produced at the centre by the same current will be :
 (A) a quarter of its first value (B) a half of first value
 (C) four times its first value (D) unaltered
9. A wire as shown in figure carries a current I ampere. The semicircle has a radius r . The magnetic field at the centre C will be :

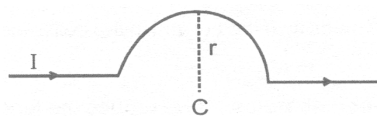

- (A) zero (B) $\frac{\pi I}{r} \times 10^{-7}$ Newton/ampere-metre
 (C) $\frac{\pi I}{r}$ Newton/ampere-metre (D) $\frac{\pi I}{r}$ gauss

SUBJECTIVE DPP- 10.2

- State the rule that is used to find the direction of field acting at a point near a current carrying straight conductor.
- What kind of magnetic field is produced due to straight solenoid ?
- What are the factors on which the magnetic field due to a current carrying solenoid depends ?

MAGNETISM AND EMI

PL-11

11.2 PERMANENT AND TEMPORARY MAGNETS :

The degree to which magnetism is retained by a given piece of iron depends entirely upon its constitution. Steel retains the largest amount while soft iron retains the least. Therefore pieces of steel are employed to prepare permanent magnets, whereas soft iron is used for preparing temporary magnets, i.e., magnets that retain their magnetism only as long as the current flows in the magnetising coil. They lose their magnetism as soon as the current is switched off. Such magnets are known as electromagnets.

11.2 (a) Electromagnet :

An electric current can be used for making temporary magnets known as electromagnets. An electromagnet works on the magnetic effect of current. When current is passed through a long coil called solenoid, a magnetic field is produced. It has been found that if a soft iron rod called core, is placed inside a solenoid then the strength of magnetic field becomes very large because the iron core gets magnetised by induction. This combination of a solenoid and a soft iron core is called an electromagnet. Electromagnets can be made in different shapes and sizes depending on the purpose for which they are to be used.

Factors affecting the strength of an electromagnet are :

- (i) **The number of turns in the coil** : If we increase the number of turns in the coil, the strength of electromagnet increases.
- (ii) **The current flowing in the coil** : If the current in the coil is increased, the strength of electromagnet increases.
- (iii) **The length of air between its poles** : if we reduce the length of air gap between the poles of an electromagnet, then its strength increases.

For example, the air gap between the poles of straight bar type electromagnet is quite large, so a bar type electromagnet is not very strong. On the other hand the air gap between the poles of a U-shaped electromagnet is small, so it is a very strong electromagnet.

Electromagnets are used in electric bells, telegraphs, telephones and several other instruments. Since the magnetisation depends on the current flowing through the coil, it is possible to obtain very powerful electromagnets by increasing the current.

Soft iron can be easily magnetised even by a weak magnetic field, whereas steel can be magnetised only by strong magnetic field.

Less energy is required for magnetising soft iron. Soft iron loses its magnetism immediately, whereas steel retains its magnetism.

11.2 (b) Difference between a Bar Magnet (or Permanent Magnet) and an Electromagnet :

S.No.	Bar magnet (or permanent magnet)	Electromagnet
(1)	The bar magnet is a permanent magnet.	An electromagnet is a temporary magnet. Its magnetism is only for the duration for which current passes through it, so the magnetism of an electromagnet can be switched on or switched off as desired.
(2)	A permanent magnet produces a comparatively weak force of attraction.	An electromagnet can produce very strong magnetic force.
(3)	The strength of a permanent magnet cannot be changed.	The strength of an electromagnet can be changed by changing the number of turns in its coil or by changing the current passing through it.
(4)	The (north-south) polarity of permanent magnet is fixed and cannot be changed.	The polarity of an electromagnet can be changed by changing the direction of current in its coil.

Permanent magnets are usually made of alloys such as carbon-steel, chromium-steel, cobalt-steel, tungsten-steel, nipermag and alonico. Nipermag is an alloy of iron, nickel, aluminum and titanium whereas ALNICO is an alloy of aluminum, nickel and cobalt. Permanent magnets of these alloys are much more stronger than those made of ordinary steel, such strong permanent magnets are used in microphones, loudspeakers, electric clocks, ammeters, voltmeters, speedometers and many other devices.

11.2 (c) Methods of Demagnetising a Permanent Magnet :

(i) Magnet can be demagnetised by :

(A) Self - demagnetisation, if the magnet is strode without using magnetic keepers.

(B) Dropping it from a height or by rough handling.

(C) Heating or hammering the magnet.

(ii) Magnet can be demagnetised by placing it within a solenoid and passing high frequency AC through it.

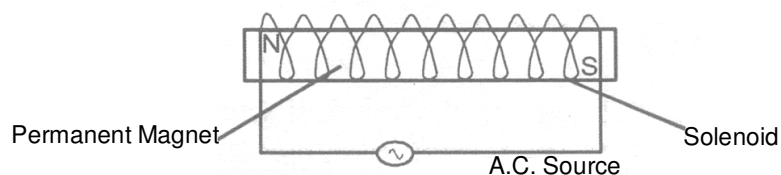

11.3 USED OF MAGNETISM IN MEDICINE :

An electric current always produces a magnetic field. Even weak ion currents that travel along the nerve cells in our body produce magnetic fields.

When we touch something, our nerves carry an electric impulse to the muscles we need to use. The impulse produces a temporary magnetic field. These fields are very weak and are one billionth of the earth's magnetic field. Heart and brain are the two main organs in the human body where the magnetic field produced is significant. The magnetic field inside the body forms the base of obtaining the images of different body parts. This is done by using a technique called Magnetic Resonance Images (MRI). Analysis of these images helps in medical diagnosis. Magnetism has thus, got important uses in medicine.

11.4 MAGNETIC FORCE :

11.4 (a) Force on a Current-Carrying Conductor in a Magnetic Field :

Immediately after Oersted's discovery of electric currents producing magnetic fields and exerting forces on magnets, Ampere suggested that magnet must also exert equal and opposite force on a current-carrying conductor. When a current carrying conductor is kept in a magnetic field (not parallel to it), a force acts on it. This force is created due to the interaction of magnetic field of the current in the conductor and the external magnetic field on the conductor. As a result of this superposition, the resultant magnetic field on one side of conductor is weaker than on the other side. hence the conductor experience a resultant force in one direction.

Take a small aluminum rod AB. Suspend it horizontally by means of two connecting wires from a stand. Now, place a strong horseshoe magnet in such a way that the rod is between the two poles with the field directed upwards. If a current is now passed in the rod from B to A, we will observe that the rod gets displaced. This displacement is caused by the force acting on the current-carrying rod. The magnet exerts a force on the rod directed towards the right, with the result the rod will get deflected to the right. If we reverse the current or interchange the poles of the magnet, the deflection of the rod will reverse, indicating thereby that the direction of the force acting on it gets reversed. This shows that there is a relationship among the directions of the current, the field and the motion of the conductor.

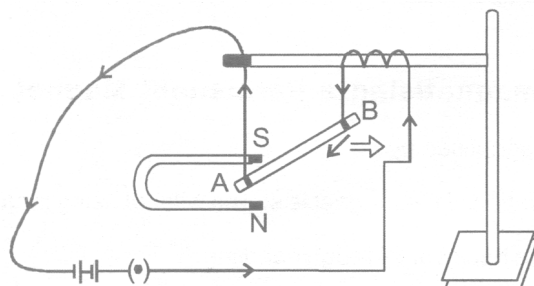

11.4 (b) Direction of Force on Current Carrying Conductor :

The direction of force obtained by the Fleming's left hand rule.

Fleming left hand rule :

Stretch the forefinger, middle finger and the thumb of you left hand mutually perpendicular to each other as shown in figure. If the forefinger indicates the direction of the magnetic field and the middle finger indicates the direction of current, then the thumb will indicated the direction of motion (i.e., force) on the conductor.

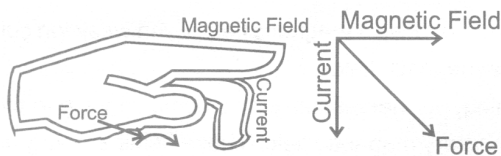

11.4 (c) Magnitude of Force :

Experimentally it is found that the magnitude of the force acting on a current carrying conductor kept in a magnetic field in direction perpendicular to it, depends on the following factors :

- (i) The force F is directly proportional to the current flowing in the conductor, i.e. $F \propto I$.
- (ii) The force F is directly proportional to the intensity of magnetic field, i.e. $F \propto B$.
- (iii) The force F is directly proportional to the length of the conductor (inside the magnetic field), i.e. $F \propto \ell$

Combining these we get, $F \propto I B \ell$ Or $F = K I B \ell$

Where K is constant whose value depends on the choice of units. In S.I. units $K = 1$ and the unit of magnetic field is tesla (T). 1 tesla is equal to 1 Newton ampere⁻¹ metre⁻¹ or 1 Weber metre⁻². Force is directly proportional to $\sin \theta$ where θ is the angle between current and the direction of magnetic field. i.e. $F \propto \sin \theta$

Combining all we have $F = B I \ell \sin \theta$ or $\vec{F} = I(\vec{\ell} \times \vec{B})$

Special cases :

- (i) When $\theta = 0^\circ$ or 180° , $\sin \theta = 0 \Rightarrow F = 0$

Force on a current - carrying conductor placed parallel or ant parallel to field is zero.

- (ii) If $\theta = 90^\circ$, $\sin 90^\circ = 1$, $F = B I \ell$ is the maximum force. Force experienced by the conductor is maximum when placed perpendicular to magnetic field.

- (iii) If $B = 0$, $F = 0$ i.e. the coil placed in field free area doesn't experience any force.

A moving charge in a magnetic field (direction of motion not parallel to the field direction) experiences a force called Lorentz force. Since current is due to flow of charge, therefore a conductor carrying current will experience a force.

The force acting on a current - carrying conductor placed in a magnetic field is :

$$F = B I \ell$$

Now, if a charge Q flows in time t then the current $I = \frac{Q}{t}$. So, writing $\frac{Q}{t}$ in place of I in the above equation, we get :

$$F = \frac{B \times Q \times \ell}{t}$$

Suppose the particle carrying the charge Q travels a length ℓ in time t . Then the velocity v of the charged

particle will be equal to $\frac{\ell}{t}$. Writing v in place of $\frac{\ell}{t}$ in the above equation, we get :

Force on moving charge, $F = B \times q \times v$

Where B = Magnitude of magnetic field, Q = Charge on the moving particle and v = Velocity of the charged particle (in metre per second). In vector notation $\vec{F} = Q(\vec{v} \times \vec{B})$

DAILY PRACTICE PROBLEMS # 11**OBJECTIVE DPP - 11.1**

- The intensity of a magnetic field is defined as the force experienced by a :
 (A) standard compass (B) unit positive charge
 (C) unit negative charge (D) unit north pole
- A wire carrying a current of 5A is placed perpendicular to a magnetic induction of 2T. The force on each centimeter of the wire is :
 (A) 1N (B) 100 (C) 0.1 N (D) 10 N
- If a soft iron piece is buried under the surface of earth in the north and south direction, then
 (A) it will acquire the properties of a magnet (B) its properties will not change
 (C) it will behave like an insulator (D) can't say with surity
- Force acting on a stationary charge **Q** in the magnetic field **B** is -
 (A) BQV (B) BV/Q (C) Zero (D) BQ/V
- A proton is moving with velocity 10^4 m/s parallel to the magnetic field of intensity 5 tesla. The force on the proton is -
 (A) 8×10^{-15} N (B) 10^4 N (C) 1.6×10^{-19} N (D) Zero
- A wire of length ℓ is placed in a magnetic field **B**, If the current in the wire is **I**, then maximum magnetic force on the wire is :
 (A) $BI\ell$ (B) $\frac{B}{I\ell}$ (C) $\frac{I\ell}{B}$ (D) $\frac{I}{B\ell}$
- The permanent magnets are kept with soft iron pieces at ends and keepers :
 (A) to magnetise the soft iron pieces (B) to increase the strength of the magnets
 (C) to avoid self demagnetisation (D) for physical safety of the magnets

SUBJECTIVE DPP-11.2

- How can we find the direction of magnetic force on current carrying conductor ?
- What is an electromagnet ? How dose it differ from a permanent magnet ? State three factor on which the strength of an electromagnet depends.
- State Fleming's left hand rule.
- The pole faces of a permanent magnet are shown in the figure. A wire of length 4 cm, carrying a current of 10A is placed in the central region, where the magnetic field is 0.2T. Calculate the magnitude of the force on the wire ?

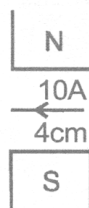

MAGNETISM AND EMI

12.1 ELECTROMAGNETIC INDUCTION :

When an electric current is passed through a conductor, a magnetic field is produced around the conductor. Faraday thought that as a magnetic field is produced by electric current, it should be possible to produce an electric current by the magnetic field. According to him, whenever there is a change in the magnetic lines of force associated with a conductor, an electromotive force (e.m.f.) is set up at the ends of the conductor which lasts as long as the change is taking place. This phenomenon is called electromagnetic induction.

12.1 (a) Faraday's Experiments :

Wind an insulated copper wire on a wooden cylinder so as to form a solenoid coil. Connect the two ends of the coil to the centre of galvanometer. A magnet is placed along the axis of the coil.

- (i) When the magnet is stationary, there is no deflection in the galvanometer. The pointer reads zero as shown in figure (A).
- (ii) When the north pole of the magnet is brought near the coil, the current flows in the coil in direction shown in the figure (B) and the galvanometer shows the deflection towards the right.

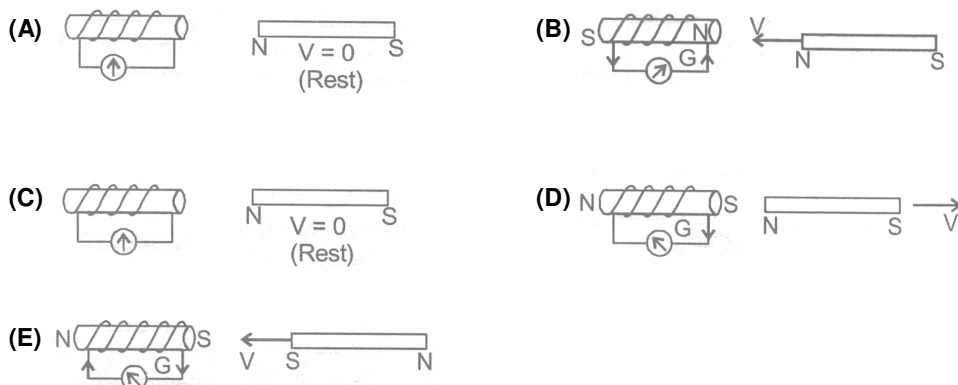

- (iii) If we stop the motion of the magnet, the pointer of the galvanometer comes to the zero position as shown in figure (C). Thus the current in the coil flows so long as the magnet is moving. If the magnet is taken away from the coil, the current again flows in the coil but in the direction opposite to that shown in figure (D) and therefore the pointer of the galvanometer deflects towards the left.
- (iv) If south pole of the magnet is brought towards the coil, the current in the coil flow in the direction opposite to that shown in figure (E) and so the pointer of the galvanometer deflects towards the left.
- (v) Similar deflection is observed in the galvanometer if the magnet is kept stationary and the coil is moved.

From this experiment Faraday concluded that :

- (i) The galvanometer shows a deflection (i.e. current flow in the coil) only when there is relative motion between the coil and the magnet.
- (ii) The direction of deflection is reversed if the direction of motion is reversed.

(iii) The value of the current in the coil (i.e. deflection of the pointer) is increased by :

- (A) The rapid motion of the magnet or the coil.
- (B) the use of a strong magnet.
- (C) increasing the area and number of turns in the coil.

When the magnet and coil are relatively at rest, the total number of magnetic lines of force due to the magnet passing through the coil (i.e. the magnetic flux linked with the coil) remains constant, therefore no e.m.f. is induced in the coil and the galvanometer shows no deflection.

When there is relative motion between the coil and magnet, the magnetic flux linked with coil changes. If the coil is moved towards the magnet, the magnetic flux through the coil increases as shown in fig. Due to change in magnetic flux linked with the coil, an e.m.f. is induced in the coil. This e.m.f. causes a current to flow if the circuit of the coil is closed.



12.1 (b) Faraday's Laws of Electromagnetic Induction :

Faraday formulated the following two laws of electromagnetic induction :

- (i) Whenever there is a change in magnetic flux linked with a conductor, an em.f. is induced. The induced e.m.f. lasts so long as there is a change in magnetic flux cut by the conductor.
- (ii) The magnitude of the e.m.f. induced is directly proportional to the rate of change of magnetic flux cut by the conductor. If the rate of change of magnetic flux remains uniform, a steady e.m.f. is induced. If the circuit of conductor is closed, a current flows in the conductor due to the e.m.f. induced across its ends.

12.1 (c) Direction of Induced e.m.f. :

The direction of induced e.m.f. (and hence the direction of induced current) can be obtained by any of the following rules :

- (i) Fleming's right hand rule
- (ii) Lenz's law

(i) **Fleming's right hand rule** : Stretch the thumb, middle finger and the forefinger of your right hand mutually perpendicular to each other as shown in figure. If the forefinger indicated the direction of the magnetic field and the thumb indicated the direction of motion of the conductor, the middle finger will indicate the direction of induced current.

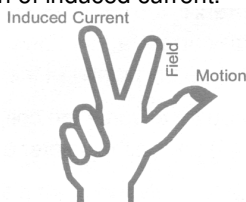

(ii) **Lenz's law** : This law gives us the direction of current induced in a circuit.

According to Lenz's law, the induced current will appear in such a direction that it opposes the change (in magnetic flux) responsible for its production.

The law refers to induced currents, which means that it applies only to closed circuits. If the circuit is open we would find the direction of induced e.m.f.

For example, in figure, when the magnet is moved towards the loop, a current is induced in the loop. The

induced current produces its own magnetic field with magnetic dipole moment \vec{M} oriented so as to oppose the motion of the magnet. Thus the induced current must be anticlockwise as shown in figure below.

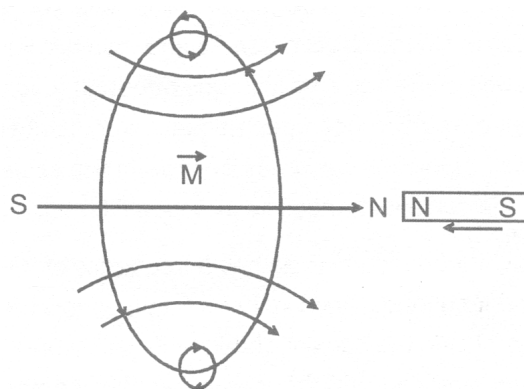

12.2 GENERATOR :

This is a device which converts mechanical energy into electrical energy using the principle of electromagnetic induction. It is of two types :

12.2 (a) AC Generator or Dynamo :

When a coil (conductor) is rotated in a magnetic field, the magnetic flux linked with it changes and therefore an alternating e.m.f. is induced in the coil.

Construction : The main parts of dynamo are :-

- (i) **Field magnet :** It is a strong horse shoe permanent magnet. An electromagnet run by a DC source can also be used for high power generators.
- (ii) **Armature:** It is a soft iron core on which a coil ABCD having a large number of turns of insulated copper wire is wound. This armature (or coil) is rotated rapidly in the magnetic field between the poles of the magnet.
- (iii) **Slip rings :** The ends of the armature (or the coil) are connected to two coaxial metallic slip rings S_1 and S_2 which rotate along with the coil.
- (iv) **Brushes :** Two brushes B_1 and B_2 made of carbon, press against the slip rings S_1 and S_2 respectively. The external circuit (i.e. load) is connected between the other ends of brushes. The brushes B_1 and B_2 do not rotate along with the coil.

Working of an AC generator :

Suppose that the generator coil ABCD is initially in the horizontal position. Again suppose that the coil ABCD is being rotated in the anticlockwise direction between the poles N and S of a horse-shoe type magnet.

- (i) As the coil rotates in the anticlockwise direction, the side AB of the coil moves down cutting the magnetic lines of force near the N- pole of the magnet and side CD moves up, cutting the lines of force near the S-pole of the magnet. Due to this induced current is produced in the side AB and DC of the coil. On applying Fleming's right-hand rule to the sides AB and DC of the coil, we find that the currents are in the directions B to A and D to C. Thus, the induced currents in the two sides of the coil are in the same direction and we get an effective induced current in the direction BADC.
- (ii) After half revolution, the sides AB and DC of the coil will interchange their positions. The side AB will come on the right hand side and side DC will come on the left hand side. So, after half a revolution, side AB starts moving up and side DC starts moving down. As a result of this, the direction of induced current in each side of the coil is reversed after half revolution. Since the direction of induced current in the coil is reversed after half revolution so that polarity (positive and negative) of the two ends of the coil also changes after half revolution. The end of coil which was positive in the first half of rotation becomes negative in the second half. And the end which was negative in the first-half revolution becomes positive in the second half of revolution. Thus, in 1 revolution of the coil, the current changes its direction 2 times.

The alternating current (**AC**) produced in India has a frequency of 50 Hz. That is, the coil is rotated at the rate of 50 revolutions per second. Since in 1 revolution of coil, the current changes its direction 2 times, so in 50 revolutions of coil, the current changes its direction $2 \times 50 = 100$ times. Thus, the AC supply in India changes its direction 100 times in 1 second. Another way of saying this is the alternating current produced in India changes its direction every $1/100$ second. That is, each terminal of the coil is positive (+) for $1/100$ of a second and negative (-) for the next $1/100$ of a second.

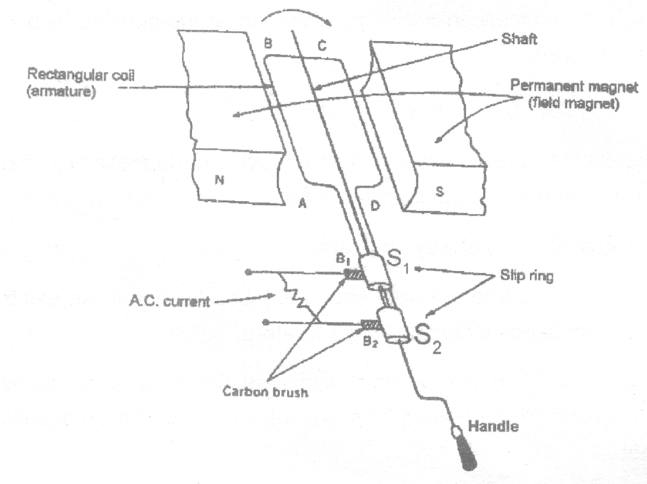

After every half revolution, each side of the generator coil starts moving in the opposite direction in the magnetic field. The side of the coil which was initially moving upwards, after half revolution, it starts moving downwards. Due to the change in the direction of motion of the two sides of the coil in the magnetic field every half revolution, the direction of current produced in them also changes after every half revolution.

12.2 (b) DC Generator (or DC Dynamo) :

“DC generator” means “Direction Current generator”. That is, a DC generator produces direct current

Construction of a DC Generator :

A simple DC generator consists of a rectangular coil ABCD which can be rotated rapidly between the poles north and south of a strong horse-shoe type magnet M.

The generator coil is made of a large number of turns of insulated copper wire. The two ends of the coil are connected to the two copper half rings (or split rings) R_1 and R_2 commutator. There are two carbon brushes B_1 and B_2 which press lightly against the two half rings. When the coil is rotated, the two half rings R_1 and R_2 touch the two carbon brushes B_2 and B_2 one by one. So, the current produced in the rotating coil can be tapped out through the commutator half rings into the carbon brushes. From the carbon brush B_1 and B_2 , we can take the current into the various electrical appliances like radio, T.V., electric iron, bulbs, etc.

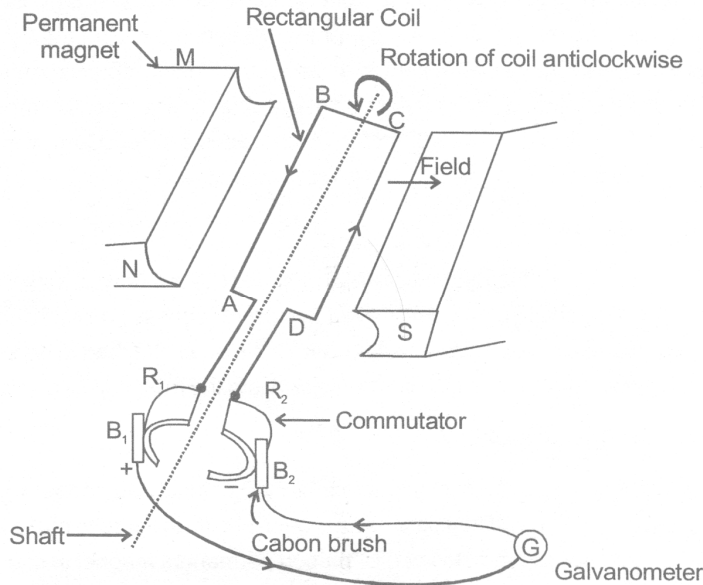

D.C. Genetator (or D.C. Dynamo)

Working of a DC generator :

Suppose that the generator coil ABCD is initial in the horizontal position. Again suppose that the coil ABCD is being rotated in the anticlockwise in the anticlockwise direction between the poles N and S of a horse-shoe type magnet.

- (i) As the coil rotates in the anticlockwise direction, the side AB of the coil move down cutting the magnetic lines of force near the N-pole of the magnet and side DC moves up, cutting the lines of force near the S-pole of the magnet in figure. Due to this, induced current is produces in the sides AB and DC of the coil. On applying Fleming's right-hand rule to the sides AB and DC of the coil we find that the currents in them are in the directions B to A and to C respectively. Thus, we get an effective induced current in the direction BADC. Due to this the brush B_1 becomes a positive (+) pole and brush B_2 becomes negative (-) pole of the generator.
- (ii) After half revolution the sides AB and DC of the coil will interchange their positions. The side AB will come on the right hand side and start moving up whereas side DC will come on the left-hand side and start moving down. But when sides of the coil interchange their position, then the two commutator half rings R_1 and R_2 automatically change their contacts from one carbon brush to the other. Due to this change, the current keeps flowing in the same direction in the circuit. Te brush B_1 will always remain positive terminal and brush B_2 will always remain negative terminal of the generator. Thus, a DC generator supplies a current in one direction by the use of a commutator consisting of two half-rings of copper.

Difference between a DC generator and an AC generator :

In a DC generator we connect the two ends of the coil to a commutator consisting of two, half rings of copper. On the other hand, in an AC generator, we connect the two ends of the coil to two full rings of copper called slip rings.

12.3 ELECTRIC MOTOR :

A motor is a device which converts electrical energy into mechanical energy. Every motor has a shaft or spindle which rotates continuously when current is passed into it. The rotation of its shafts is used to drive the various types of machines in homes and industry. Electric motor is used in electric fans, washing machines, refrigerators, mixer and grinder and many other appliances. A common electric motor works on direct current. So, it is also called DC motor, which means a "Direct Current motor"/ The electric motor which we are going to discuss now is actually a DC motor.

12.3 (a) Principle of a Motor :

An electric motor utilizes the magnetic effect of current. A motor works on the principle that when a rectangular coil is placed in a magnetic field and current is passed through it, a torque acts on the coil which rotates continuously. When the coil rotates, the shaft attached to it also rotates. In this way the electrical energy supplied to the motor is converted into the mechanical energy of rotation.

12.3 (b) Construction of a Motor :

An electric motor consists of a rectangular coil ABCD of insulated copper wire, wound on a soft iron core called armature. The soft iron core has not been shown in figure to make things simple. The coil is mounted between the curved poles of a U-shaped permanent magnet in such a way that it can rotate between the poles N and S. The two ends of the coil are soldered (or welded) permanently to the two half rings X and Y of a commutator.

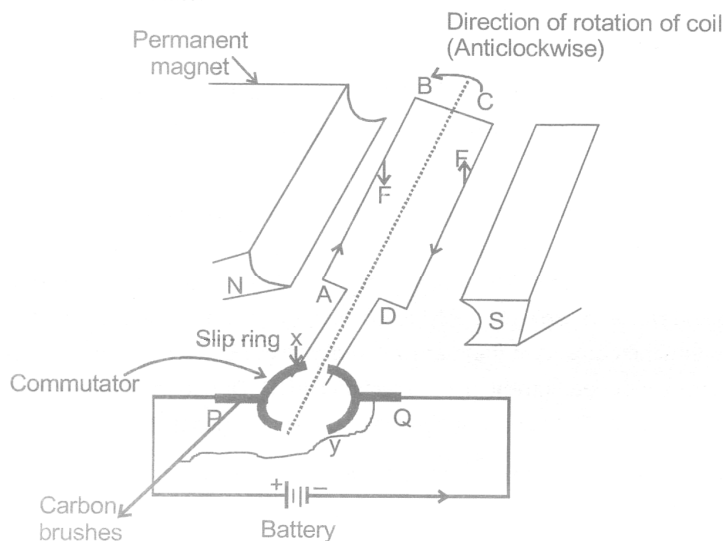

An electric motor

A commutator is a copper ring split into two parts X and Y, these two parts are insulated from one another and mounted on the shaft of the motor.

End A of the coil is welded to part X of the commutator and end D of the coil is welded to part Y of the commutator. The commutator rings are mounted on the shaft of the coil and they also rotate when the coil rotates.

The function of commutator rings is to reverse the direction of current following through the coil every time the coil just passes the vertical position during a revolution.

We cannot join the battery wire directly to the two commutator's half rings to pass current into the coil because if we do so, then the connecting wires will get twisted when the coil rotates. So, to pass the electric current to the coil, we use two carbon strips P and Q known as brushes. The carbon brushes P and Q are fixed to the base of the motor and they press lightly against the two half rings of the commutator. The function of carbon brushes is to make contact with the rotating rings of the commutator and through them to supply current to the coil. It should be noted that any one brush touches only one ring at a time, so that when the coil rotates, the two brushes will touch both the rings one by one.

12.3 (c) Working of a Motor :

Suppose that initially the coil ABCD is in the horizontal position as shown in figure. On pressing the switch, the current enters the coil through carbon brush P and commutator half ring X. The current flows in the direction ABCD and leaves via ring Y and brush Q.

- (i) In side AB of the coil, the direction of current is from A to B and the direction of magnetic field is from N to S pole. So, by applying Fleming's left hand rule to the side AB of the coil we find that it will experience a force in the upward direction.
- (ii) In side DC of the coil, the direction of current is from C to D towards but the direction of magnetic field remains the same from N to S pole as shown in figure. So, by applying Fleming's left hand rule to the side DC of the coil, we find that. It will experience a force in the downward direction.
- (iii) We find that the force acting on the side AB of the coil is in the upward direction whereas the force acting on the side DC of the coil is in the downward direction. These two equal, opposite and parallel forces acting on the two sides to the coil form a couple (torque) and rotate the coil in the anticlockwise direction.
- (iv) While rotating, when the coil reaches the vertical position, then the brushes P and Q will touch the gap between the two commutator rings and current to the coil is cut off. Though the current to the coil is cut off when it is in the exact vertical position, the coil doesn't stop rotating because it has already gained momentum due to which it goes beyond the vertical position.
- (v) When the coil goes beyond the vertical position, the two commutator's half rings automatically change contact from one brush to the other. This reverses the direction of current through the coil which, in turn, reverses the direction of forces acting on the two sides of the coil. The side AB of the coil now be one the left hand side with a downward force on it, whereas side DC of the coil will come on the right hand side with an upward force on it. In this position also a couple acts on the coil which rotates it in the same direction (anticlockwise direction). This process is repeated again and again and the coil continues to rotate as long as the current is passing. This is how an electric motor works.

DAILY PRACTICE PROBLEMS # 12

OBJECTIVE DPP - 12.1

- The device which is used for converting mechanical energy into electrical energy is called :
(A) electric motor (B) dynamo (C) transformer (D) battery
- In case of a DC generator a large number of coils each having many turns and arranged in different turns are used :
(A) to get high voltage DC (B) to get high ampere DC
(C) to get smooth DC (D) get pulsating current
- Lenz's law is a consequence of the law of conservations of :
(A) energy (B) momentum (C) angular momentum (D) charge and mass
- In a DC generator, the induced e.m.f. in the armature is :
(A) DC (B) AC (C) fluctuating DC (D) both AC and DC
- The induced emf produced when a magnet is inserted into a coil does not depend upon :
(A) the number of turns in the coil (B) the resistance of the coil
(C) the magnetic moment of the magnet (D) the speed of approach of the magnet
- Lenz's law :
(A) is the same as the right palm rule
(B) determines the magnitude of an induced emf
(C) bears no relation to the law of conservation of energy
(D) is useful in deciding about the direction of an induced emf
- When the current through a solenoid increases at a constant rate, the induced current :
(A) is a constant and in the direction of inducing current
(B) is a constant and is opposite to the direction of inducing current
(C) increases with time and is in the direction of inducing current
(D) increases with time and opposite to the direction of inducing current
- The device which is used for converting electrical energy into mechanical energy is called :
(A) electric (B) dynamo (C) transformer (D) battery
- The current in the armature of a dc motor is maximum when :
(A) the motor achieves maximum speed (B) the motor achieves intermediate speed
(C) the motor is switched on (D) the motor is switched off
- The effect of using split rings in a simple DC motor is that :
(A) the direction of rotation of the coil is reversed
(B) the current in the coil always flows in the same direction
(C) the direction of the current flowing in the coil is reversed
(D) None of these

SUBJECTIVE DPP - 12.2

1. Name two types of electric generators.
2. What is the principle on which a DC generator works ?
3. Out of an AC generator an DC generator.
 - (i) Which one uses a commutator (split) rings ?
 - (ii) Which one uses slip rings ?
4. A motor converts one form a energy into another. Name the two forms. Draw the diagram of electric motor and also describe it.
5. What is the function of a commutator in an electric motor ?
6. Of what substance is the core of the coil of an electric motor made ?

ANSWERS

Objective DPP 10.1

Q.	1	2	3	4	5	6	7	8	9
A.	B	B	C	B	D	B	C	C	B

Objective DPP 11.1

Q.	1	2	3	4	5	6	7
A.	D	C	A	C	D	A	C

Subjective DPP 11.2

4. 0.08 N

Objective DPP 12.1

Q.	1	2	3	4	5	6	7	8	9	10
A.	B	C	A	B	B	D	B	A	C	C

SOURCES OF ENERGY

Energy is the capacity of a body for doing work. Energy stored in a body or system is equivalent to total work done by the body till whole of its energy has been completely exhausted. Most of our energy requirement is fulfilled from the fuels & electricity. Solar energy is also available to us in the form of a variety of fuels that have been stored in the earth's crust. Energy can be converted from one form to another.

13.1 SOURCES OF ENERGY :

We have a wide range of sources of energy such as the sun, the wind, the earth geothermal), flowing water, coal, gasoline, diesel, natural gas, biogas, etc. at our disposal. We utilize this energy to perform a wide range of activities, i.e. industrial, commercial, household etc.

13.1 (a) Types of Sources of Energy :

There are two types of sources of energy :

(i) **Renewable sources of energy (or non-conventional sources of energy):**

The sources of energy which are in constant supply to us by nature and are inexhaustible are known as renewable sources of energy.

Example : The sun (solar energy), oceans, tidal energy, wind energy, running water energy, wood, geothermal energy etc.

(ii) **Non- renewable sources of energy (or conventional sources of energy):**

The sources which can't used again and again and are exhaustible are known as non-renewable sources of energy.

Example : Coal, natural gas, petroleum, fossil fuels etc.

13.1 (b) Characteristics of Sources of Energy :

For a good source of energy, following conditions must be fulfilled by it :

- (i) It should provide large amount of useful energy.
- (ii) It must be easily storable in small space.
- (iii) It must be easily transportable.
- (iv) It must provide the energy in regular manner.
- (v) It should be convenient to use.

13.2 SOLAR ENERGY :

The sun is the primary source of energy for all living beings on the earth. It provides all of us heat and light. The energy generated by the sun is the result of reaction called nuclear fusion, occurring continuously in the interior part of the sun. Hans Bethe, a physicist proposed that the enormous release of energy from the sun is due to the fusion (combination) of four hydrogen atoms to yield a single helium atom ($\frac{4}{2}\text{He}$). For this discovery he was awarded the 1967 Noble prize in Physics. The sun emits energy in all directions in space. Solar energy is trapped by plains, plateaus, mountains, rivers, lakes, oceans and ponds. Plants use solar energy to manufacture food by photosynthesis and also solar energy is the source of wind storms, rain, snow fall & ocean waves.

It is the perennial (forever) source of energy.

This perennial source of energy has some features :

- (i) It comes to earth surface in a very diffused form.
- (ii) Upper atmosphere gets 1.3 KJ of energy per second per square meter of this only 47% i.e. approximately 0.64 KJ energy reaches per second per square meter on earth's surface.
- (iii) Moreover this amount of energy is not available uniformly and keeps changing everyday at a place and place to place during a day.

13.2 (a) Composition of Solar Energy (Sunlight):

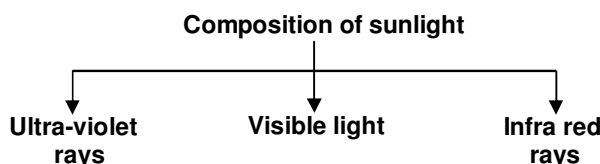

(i) Ultra violet rays :

The invisible rays whose wavelength is shorter than that of the visible violet light are called ultra violet rays. We can detect these rays by using a photographic film or a fluorescent paper because they darken the photographic film just like ordinary light rays. They are used to kill bacteria in food stuff and drinking water. Too much ultra-violet radiation is dangerous for our health due to its ionising effect and can cause skin cancer.

(ii) Visible light :

The visible rays whose wavelength range from 400 nm (in violet) to 700 nm (in red) are called visible light. The visible part of the sunlight consists of seven different wavelet, each wavelength corresponding to a different colour. Thus the visible part of the sunlight consists of seven different colours.

(iii) Infra - red rays :

The invisible rays whose wavelength is longer than that of the visible red light are called infra-red rays. They can heat the object on which they fall. About one-third of the solar energy consists of infra-red rays. They can be detected by its heating effect, by using a thermometer. Every hot object emit infra-red rays. They are used to get relief from body aches.

13.2 (b) Uses of Solar Energy :

- (i) Solar cooker absorb solar energy and cook food,
- (ii) Solar water heaters are used for heating water.
- (iii) Solar cell convert solar energy into electricity to run watches, calculators and in spaceships for various experiments.
- (iv) Solar energy is absorbed by green plants to make their food by photosynthesis.
- (v) Solar energy is used for drying clothes and food grains.
- (vi) Solar energy is used for making salt from sea water.

13.2 (c) Advantages of Solar Energy :

- (i) It is inexhaustible and renewable as it producing continuously in the core of sun by nuclear fusion of H-atoms.
- (ii) Its quantity is unlimited and is available in all parts of the world in abundance.
- (iii) It does not cause any pollution.
- (iv) It can be put to practical appliances.

13.2 (d) Limitations of Solar Energy :

- (i) It is not available at night.
- (ii) It is not available uniformly in all parts of world.
- (iii) Solar energy received by the earth is quite diffused and in scattered form and hence only a part of it is utilized.
- (iv) It is not available at constant rate due to clouds, fog, mist, haze, winds etc.

13.2 (d) Direct and Indirect Harnessing (or Collection) of Solar Energy :

- (i) Direct utilization of solar energy can be done by collecting the heat radiation on reflecting these by plane mirrors on to black boxes containing uncooked food (in solar cooker) and for heating water in solar heaters. These rays can be converted into electrical energy as in solar cells.
- (ii) Indirect utilization of solar energy can be done by first converting solar energy into chemical energy as in biomass of plants. Heat energy of sun can be utilized in sea waves (ocean thermal energy) and into energy of winds etc.

13.2 (f) Solar Heating Devices :

These are the devices which can collect and store heat obtained from solar energy. These are used for heating and cooking purposes. Solar heating devices are designed in such a way so that these can make maximum utilization of solar heat radiations. It is done by adopting following procedure :

(i) Concentration of solar energy of using reflectors :

For moderate heating sun rays are reflected by using plane mirrors, as in solar cookers and solar water heaters. For high temperature, sun's energy is concentrated using concave mirrors as reflectors.

(ii) Black paint :

Since black bodies are good absorbers as well as good radiators of heat, hence black paint is used to absorb and store heat radiations in large quantity by using large surface area.

(iii) Glass - sheet cover :

Glass sheet cover is used to protect the hot infra red rays of solar energy from escaping the body of black box. It allow the IR radiations (of shorter wavelength) to enter the box of solar heating device and do not allow IR radiations (of longer wavelength) to escape from the solar heating device. Hence more heat is retained by solder heating device for long time.

(A) Box type solar cooker :

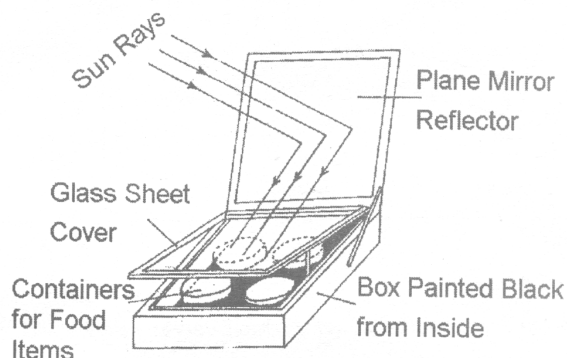

Solar cooker is a device used for cooking food with the help of solar energy. A box is made of a non - conducting material like plastic or fiber glass and painted black from inside is used for making the solar cooker.

The cooker is placed in the sunlight and the position of the reflector is adjusted in such a ways that a strong beam of light falls over the cooker top. These rays pass through the transparent glass sheet, therefore the box and the containers absorb maximum amount of infra red radiations from the sunlight falling on it. As a result the temperature inside the box rises to about 100°C to 130°C.

(B) Spherical reflector type solar cooker :

In this type of solar cooker, there is an insulated metal box, painted black from inside. A spherical reflector is used here (in place of plane mirror) Because a very high temperature is required, the spherical reflector is either a concave reflector or a parabolic reflector. The sunlight falling on the surface of spherical reflector get concentrate to one point. This will produce a lot of heat at that point & temperature in that region will become very high, therefore in this type, an utensil is placed at this point. Since a high temperature can be produced, so it can be used for making chapattis and for frying purposes.

Difference between box – type & spherical reflector type solar cooker			
Box – type solar cooker		Spherical reflector type solar cooker	
1	A plane mirror reflector is used.	1	Spherical reflector is used
2	In a box type solar cooker, comparatively low temperature is produced	2	Quite high temperature is produced in the spherical reflector type solar cooker.
3	It cannot be used for making chapatties	3	It can be used for frying and making chapatties
4	Used for cooking food requiring slow heating.	4	Used for cooking food requiring strong heating.

(C) Solar cells :

Solar cells is a device which converts solar energy directly into electricity. Energy radiated from the sun also contains light energy. So solar cells are also known as photo voltaic cells. The process of generating electricity directly from sunlight is referred to as a photo voltaic effect. The photo voltaic effect occurs when solar radiation strikes certain sensitive material directly and results in the flow of electrons. It was found that when 0.6% of the solar energy falling on the selenium layer got converted into electricity. With the advancement in the field of semiconductors, the solar cells made from these semiconductors can convert 10 to 15% of solar energy into electricity.

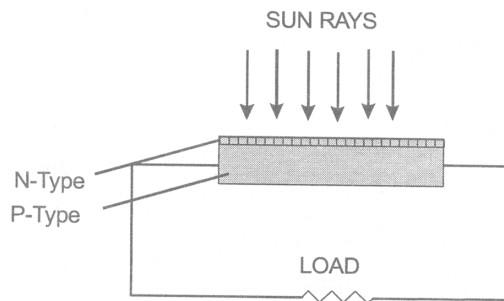

(a) Semi-conductors :

Semi-conductors are those substances which have very low electrical conductivity. Under ordinary conditions, semi-conductor materials conduct only a small amount of electric current. But if certain impurities are added to semi-conductor materials then their electrical conductivity increases considerably. Semi-conductors are neither good conductor of electricity nor they are completely insulators. The process of adding impurity is called doping/ The material (semiconductors) doped with boron has an affinity to attract electrons and is termed as p-type (acceptor) semiconductor. The phosphorous doped silicon material, which has a surplus of electrons, is termed as n-type (donor) semiconductor. When solar energy falls on semi-conductor material, even then their electrical conductivity increases.

(b) Conduction of solar cell :

It is constructed usually from silicon & gallium. Its conductivity increases when light falls on them. Therefore in a solar cell, the pieces (usually wafers) of semi conducting materials containing impurities are so arranged that when light falls on them then potential difference is produced between two regions of the semi conductor. It has been observed that a solar cell of about 4 cm² may produce potential difference of about 0.4V to 0.5V and generate and current of 60 mA. A large number of solar cell joined together in a definite pattern can provide much higher power for many use. The group of solar cell is called solar cell panel.

(c) Solar cell panel :

When solar cells are arranged side by side, connecting each other in such a way that total potential difference and the total capacity to provide electric current is much increased the arrangement is called solar cell panel. The electric power required for the working of artificial satellites in outer space, street lighting in remote areas and running of irrigation water pumps in far-off areas obtained with the help of solar cell panels. In a solar cell panel hundreds of solar cells are joined together, the electricity produced by this solar panel is stored in battery.

This battery runs an electric motor and finally the motor drives the water pump, which pump out the underground water. The various solar cells in a solar cell panel are joined together by using connecting wires made of silver. This is because silver metal is the best conductor of electricity having very low resistance. The use of silver for connecting solar cells makes the solar cell panel more expensive but it increase the efficiency. This is because if connecting wires of other metals were used in solar cell panel, then a substantial part of the electricity generated by it could be lost in overcoming the resistance of such connecting wires.

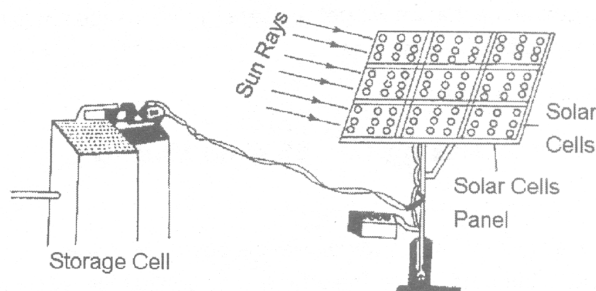

(d) Uses of solar cell :

- (i) Solar cells are used for providing electricity in artificial satellite and space probes.
- (ii) In India, solar cells are behind used for street lighting, for traffic, signals, for operating water pump and for running radio and television sets i remote areas.
- (iii) Solar cells are used for providing electricity to “lighthouses” situated in the sea and to the off - shore oil drilling ring platforms.
- (iv) Solar cells are used for operating electronic watches & calculators.

13.3 WIND ENERGY :

Moving air is called wind. As the moving objects possess K.E. and as such they are capable of doing mechanical work by virtue of its motion. Wind also possess the ability of performing mechanical work because it is air in motion. So wind energy is the K.E. associated with large mass of air by virtue of its motion.

Solar energy is responsible for the blowing of air.

This can be explained as follows : The sunrays fall on the whole earth but eh intensity of sun-rays is much more stronger near equator of the earth than in the polar regions. Due to more intense sun-light, the air near the surface of earth in equatorial regions becomes quite hot. This hot air, being lighter, rises upwards. The cooler air form the polar regions of the earth start flowing towards the equatorial regions of the earth to fill the space vacant by the hot rising air. In this way air flows from the higher pressure regions to the lower pressure regions of the earth. This flow of air from one place to another constitutes wind.

13.3 (a) Advantages of Wind Energy :

- (i) use of wind energy is not a source of pollution.
- (ii) Wind energy is available free of cost.
- (iii) The source of wind energy i.e. air is an inexhaustible and reversible source.

13.3 (b) Disadvantages of Wind Energy :

- (i) One of the most important limitation of wind energy is that it may not be available at all times.
- (ii) The windmill and sail-boats remain unoperational and no useful work can be done unless there is a plenty of fast blowing wind.
- (iii) The speed of the wind at a place varies with time and season.
- (iv) The K.E. of the wind can be utilized only at the site.
- (v) There is no guarantee that we will get wind energy when required, since there is no place in the world where wind blows all the time.
- (vi) The wind is not predictable.

13.3 (c) Practical Devices Making use of Wing Energy :

(i) Wind mill

A windmill is a machine, which works with the energy of blowing air or wind. It consists of large blades to catch the wind. When the wind strikes against these blades, They start rotating. The motion can then be passed on the other connected parts & is used to do useful work. A windmill consists of a system of big blades (or vanes) capable of rotating about a horizontal axis. The system of vanes is mounted on the top of a high tower. The system of blades in connected to one end of the rod called shaft. The other ends of the shaft is connected to a pump rod in case of water pump. This end is bend in form of inverted V and is connected to the free and of the pump rod of the water pump. When the wind blows, it rotates the bladed of the windmill. The shaft turning about its axis rotates the crank. The rotates the blades of the windmill. The shaft turning about its axis rotates the crank. The rotation of the crank moves the piston rod of the water pump up and down & draws water from the well.

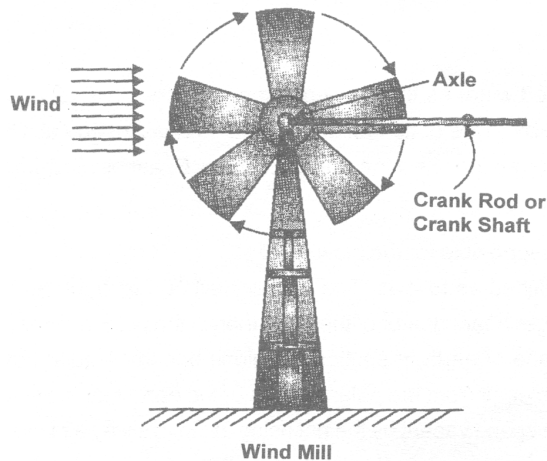

(A) Windmill to operate flourmill :

It is similar to one used to grind grains by suitable arrangements of toothed wheel & shafts. The other end of the shaft is connected to a toothed wheel. Grinding arrangement of flour mill has a fixed mill stone A and another heavy will stone B. B is capable or rotating by a shaft rod (W_2) having a toothed wheel (W_2). The wheel (W_1) is coupled with the wheel (W_2) such that the rotation of wheel (W_1) about a horizontal axis rotates the wheel (W_2) about a vertical axis. The wheel (W_1) rotates as the shaft (W_1) connected to blades rotates due to rotation of blades of windmill. Thus the K.E. of wind by virtue of this motion rotates the windmill which in turn operates a flourmill and is able to grind grains.

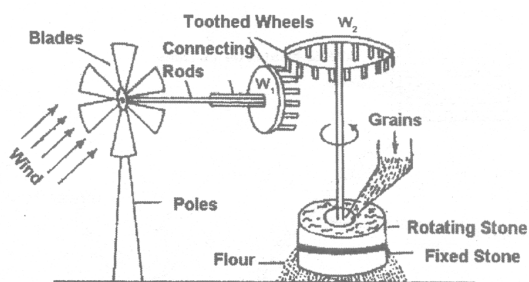

(B) Wind generator :

A modern generator, which is used to generate electricity by using wind energy is wind generator. When the fast moving wind strikes the blades of wind turbine, then the wind turbine starts rotating continuously. The coil of a small electric generator is attached to the shaft of wind turbine. So when the wind starts rotating and generates electricity. The electricity generated by a single wind turbine is quite small. So, in order to generate a large amount of electricity, a large amount of wind turbines are erected over a big area of land. Such a set-up of having a large number of wind turbines working at a place to generate electrical energy on a large scale is called a wind energy farm.

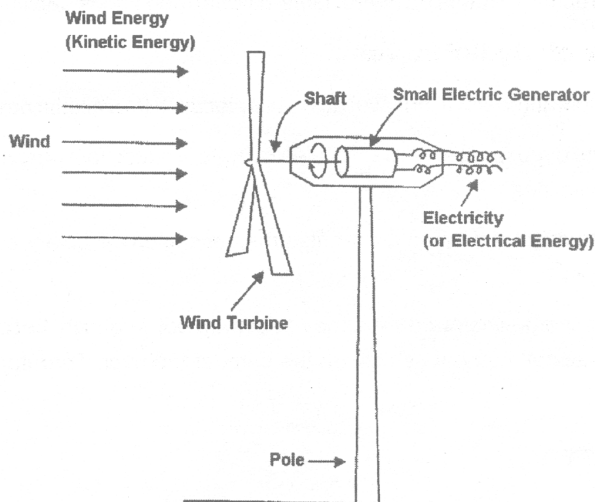

13.4 HYDRO ENERGY (HYDEL POWER) :

Flowing water having a lot of kinetic energy can be utilized as hydro energy. Hydro energy can be stored by storing water in high altitude dams. Hence it is a renewable source of energy. Solar energy is the source of hydro energy. Hydro energy is used to grind crops, to irrigate fields and to transport logs of wood from remote areas. Energy trapped in flowing water is used to generate electricity on a large scale at hydroelectric power stations. Dams are needed to be constructed to utilize the kinetic energy of flowing water. The water stored in dam is made to fall from a height through pipes and made to run over the blades of huge turbines at the bottom. This moves the turbine which in turn rotate the coils of an electrical generator to produce power or electricity.

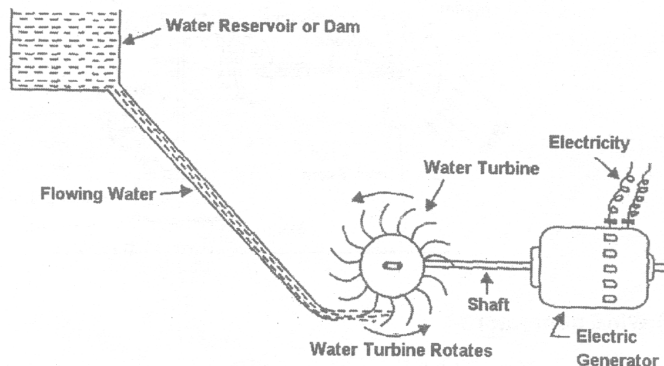

Hydro electric power plant

13.4 (a) Advantage of Hydel Power :

- (i) The process of hydel power does not cause any environment pollution.
- (ii) The moving water needed for the purpose is available free of cost.
- (iii) Water energy is a renewable source of electrical energy which will never get exhausted.
- (iv) The construction of dams on rivers helps in controlling floods and in irrigation.

13.4 (b) Limitations of Hydel Power :

- (i) Moving or flowing water is not available at all places. It is available near the sites of flowing rivers
- (ii) To generated a reasonable amount of electricity from water, fast moving water should be available in large quantities.
- (iii) The construction of dam on a river disturbs the ecological balance in downstream area of the river.
- (iv) The soil in the downstream area may become poor in quality because there were no annual floods to deposit nutrient rich silt on the bank of the river. Therefore there may be ecological problems.

13.5 TIDAL ENERGY :

The rise of ocean water due to attraction of moon is called 'high-tide' whereas the fall of ocean water is called 'low-tide'. The enormous movement of water between the high tide and low tide provides a very large source of energy in the coastal areas of the world.

During high tide, when the level of water in the sea is high, sea water flows into the reservoir of the barrage and turns the turbines. The turbines then turn the generator to produce electricity. And during the flow tide when the level of sea-water is low, the sea water stored in a barrage reservoir is allowed to flow out into the sea. This following water also turn the turbine and generate electricity.

The tidal energy is not likely to be potential source of energy in future because of following reasons :

- (i) There are very few sites around the world, which is suitable for building tidal barrages (or tidal dams).
- (ii) The rise & fall of sea water during high and low tides is not enough to generate electricity on a large scale.

13.6 SEA WAVES ENERGY :

Due to the blowing of wind on the surface of ocean, very fast sea-waves move on its surface. Due to their high speed, sea waves have a lot of kinetic energy in them. The energy of moving sea-waves can be used to generate electricity. This can be done as follows :

- (i) One idea is to set up floating generators in the sea. These would move up and down with the sea-waves. This movement would drive the generators to produce electricity.
- (ii) Another idea is to let the sea-waves move up and down inside large tubes. At the waves move up, the air in the tubes is compressed air can then be used to turn a turbine of a generator to produce electricity.

13.7 OCEAN THERMAL ENERGY :

The energy available due to the difference in the temperature of water at the surface of the ocean and at a deeper levels is called ocean thermal energy. The drives used to harness ocean thermal energy are called ocean thermal energy conversion power plants. A temperature difference of 20°C between the surface water of ocean and deeper water is needed for operating OTEC power plants. In one type of OTEC power plant, the warm surface water of ocean is used to boil a liquid like ammonia or a chlorofluorocarbon (CFC). the high-pressure vapors of the liquid are then used to run the turbine of a generator and produce electricity. The colder water from the deeper ocean is pumped up to cool the used up vapours & convert them again into a liquid. This process is repeated again and again.

Advantage of ocean thermal energy :

- (i) It can be used continuously 24 hours a day throughout the year.
- (ii) It is a renewable source of energy and its use does not cause any pollution.

13.8 GEOTHERMAL ENERGY :

Geothermal energy is the heat energy of hot rocks present inside the earth. This heat can be used as a source of energy to produce electricity. Geothermal energy is one of the few sources of energy that do not come directly or indirectly from solar energy. The places where very hot rocks occur at same depth below the surface of earth are called 'hot spots' and are sources of geothermal energy.

The geothermal energy is harnessed as follows :

- (i) The extremely hot rocks present below the surface of earth, heat the underground water and turn it into steam. As more and more steam is formed between the rocks, it gets compressed to high pressures. A hole is drilled into the earth and the hot rocks come up through the pipe at high pressure. This high-pressure steam runs the turbine of a generator to produce electricity.
- (ii) Large rocks are present in the underground rocks, which allow steam and hot water to go up. The steam & hot water gushing out of the ground are a kind of natural geyser. This steam is then used to turn turbines and generate electricity and the hot water is used to cook food.

13.9 BIO ENERGY :

The energy obtained from the biomass of plants and animals is called bio energy. Biomass is a renewable source of energy because it is obtained from plants (or animals) which are produced again and again. The waste material of living things and dead parts of living things is called biomass. Biomass includes cattle dung, wood, sewage, agricultural wastes or crop residues like bagasse (Bagasse is the remaining part of the sugar cane or ganna, from which juice has been extracted). Biomass is carbon compounds and it is the oldest source of heat energy for domestic purposes. There are two ways of using biomass as a fuel. One is to burn the dry biomass like cattle-dung or wood directly to produce heat. Another method is to convert the biomass into more useful fuels and then use these fuels for heating purposes.

13.9 (a) Biogas :

The decomposition which takes place in the absence of oxygen is called anaerobic degradation. Anaerobic degradation is carried out by anaerobic bacteria. Biogas is a mixture of methane, carbon dioxide, hydrogen and hydrogen sulphide. The major constituents of biogas is methane. Biogas is produced by the anaerobic degradation of animal wastes like animal dung in the presence of water.

13.9 (b) Biogas Plant :

Biogas is prepared by anaerobic degradation of animal wastes like cow dung in biogas plant. The two types of biogas plant are :

(i) Floating gas holder type biogas plant.

(ii) Fixed - dome type bio-gas plant.

The raw material used for producing biogas is both the plants is the same, it is a mixture of cattle dung and water.

(i) Floating gas holder type bio-gas plant :

This biogas plant consist of a well shaped underground tank called digester, which is made up of bricks. A drum shaped gas holder made of steel floats in the inverted position over the dung slurry in the digester tank. Since the gas holder floats over the dung-slurry, so this biogas plant is called floating gas-holder type biogas plant. The gas holder can move up and down, and its movement is controlled by the control pipe. There is a gas outlet at the top of the gas holder tank having a valve. A partition wall divides the digester tank in two parts: on the left of the digester tank is an inlet pipe made of cement (the inlet is connected to a mixing tank), on the right side of the digester tank is an outlet pipe, also made of cement, which is connected to an over-flow tank. The inlet pipe is for feeding the fresh dung slurry into the digester tank whereas the outlet pipe is for removing the spent dung after the extraction of biogas. Cattle dung and water are mixed in equal proportions in the mixing tank to prepare the slurry. This slurry of dung and water is fed into the digester tank through the inlet pipe. The dung undergoes anaerobic degradation in the presence of water with the gradual evolution of biogas. As more and more bio-gas collects in the gas-holder, the pressure of gas in it increases. As the spent dung slurry goes out, more fresh dung slurry is added to the digester tank on daily basis.

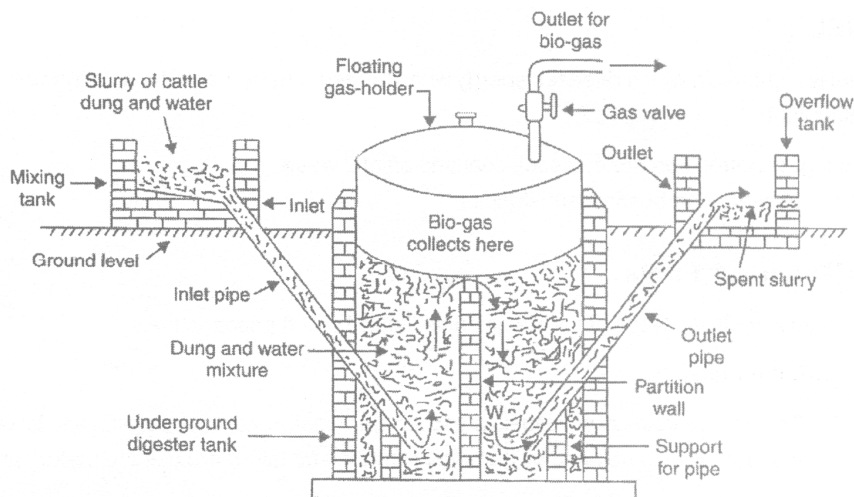

Floating gas holder type biogas plant

(ii) Fixed dome type biogas plant :

It consists of a well-shaped underground tank called digester, which is made up of bricks & has a dome-shaped roof also made of cement and bricks. The dome of the digester tank acts as a gas holder or storage tank for the biogas. In this case the gas holder is fixed. There is a gas outlet at the top of dome having a valve on the left side of the digester tank in a sloping inlet chamber and on the right side is a rectangular outlet chamber. The inlet chamber is connected to a mixing tank while the outlet chamber is connected to the overflow tank. This gas plant is unique at the digester tank & the gas-holder are combined in one unit and no separated steel gas-holder is required. Cattle dung & water are mixed in equal proportions in the mixing tank to prepare the slurry. The dome being left free for the collection of biogas. The cattle dung undergoes degradation by anaerobic bacteria in the presence of water with gradual evolution of biogas. This biogas starts collecting in the dome. As more & more biogas collected in the dome, it exerts pressure on the slurry in the digester tank and force the spent slurry to go into overflow tank through the outlet chamber from the overflow tank, the spend slurry is removed gradually.

We use cattle dung in the biogas plant, but human excreta can also be added along with cattle dung in the biogas plants. Biogas can also be obtained by the action of bacteria on domestic sewage in the absence of air. The biogas obtained from the degradation of domestic sewage is also called sewage-gas.

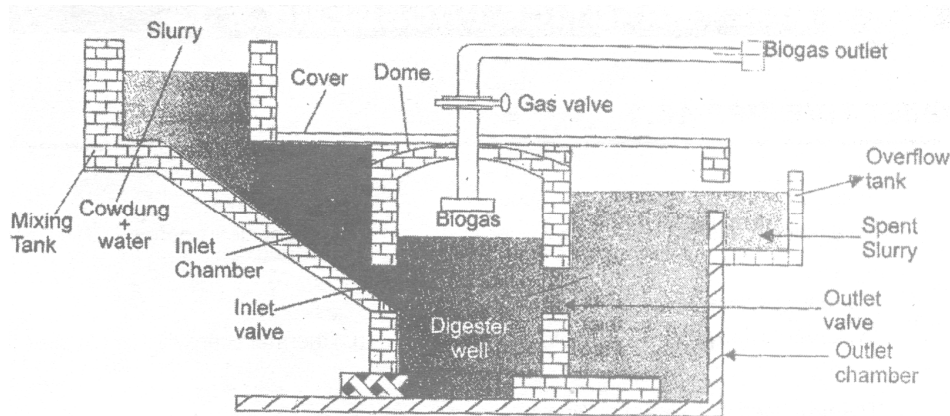

Fixed Dome Type Biogas Plant

13.10 FUEL :

A fuel is a chemical which releases energy when heated with oxygen. The energy may release in form of heat or light.

Eg : Wood, gas, petrol, kerosene, diesel, coal and animal waste.

Note : Fuels are combustible substances.

13.10 (a) Types of Fuels :

There are three types of fuels solid flues, liquid fuels & gaseous fuels.

(i) **Solid fuels :**

The various kinds of solid fuels are wood, charcoal, coke, coal, paraffin and tallow. Wood was the first solid fuel to be used by humans. Paraffin and tallow are used to make candles.

(ii) **Liquid fuels :**

Petrol, kerosene, diesel and methanol are some common liquid fuels. Most liquid fuels are obtained from petroleum. They leave no solid residue when burnt and can be stored easily.

(iii) **Gaseous fuels :**

Natural gas, coal gas producer gas, water gas and liquefied petroleum gas are some examples of gaseous fuels.

13.10 (b) Fossil Fuels :

Fossil fuels are the remains of the prehistoric animals or plants, burried under the earth, millions of years ago.

Eg. Coal, petroleum and natural gas.

Fossil fuels are formed in the absence of oxygen. The chemical effects pressure, heat and bacteria, convert the burried remains of plants & animals into fossil fuels like coal, petroleum and natural gas.

It was the sunlight of long ago that made plants grow, which were then converted into fossil fuels. Fossil fuels are energy rich compounds of carbon, which are originally made by the plants with the help of sun's energy.

DAILY PRACTICE PROBLEMS # 13

DPP - 13.1

- Solar energy can be used to produce :
(A) electrical energy (B) heat energy (C) mechanical energy (D) all of the above
- The energy processed by wind is :
(A) kinetic energy (B) potential energy (C) thermal energy (D) sound energy
- The fuel used in a stream engine is :
(A) water (B) carbon monoxide (C) carbon dioxide (D) none of these

4. A solar cell convert heat and light energy into :
(A) heat energy (B) sound energy (C) electrical energy (D) nuclear energy.
5. Biogas is a mixture of :
(A) $\text{CO} + \text{H}_2 + \text{CH}_4$ (B) $\text{CO} + \text{H}_2$
(C) $\text{CO}_2 + \text{CH}_4 + \text{H}_2 + \text{H}_2\text{S}$ (D) $\text{CO}_2 + \text{N}_2$
6. The sources of energy which are being produced continuously in nature and are inexhaustible are called :
(A) conventional sources (B) non-conventional sources
(C) non-renewable sources (D) none of these
7. Choose the source of energy which is different from others :
(A) Wood (B) Falling water (C) Wind (D) Petroleum
8. The vast amount of sea weeds present in oceans may provide an endless source of :
(A) nuclear energy (B) ocean thermal energy (C) methane (D) none of these
9. Energy available from the oceans is :
(A) OTE (B) sea-waves energy (C) tidal energy (D) all of the above
10. Radiations used to get relief from bodyaches are :
(A) I.R.radiations (B) U.V. radiations (C) Visible radiations (D) None of these
11. Wood is a :
(A) primary fuel (B) liquid fuel (C) processed fuel (D) secondary fuel
12. Which of the following is as example of fossil fuel ?
(A) Coal gas (B) Coke (C) Natural gas (D) Producer gas

SUBJECTIVE DPP - 13.2

1. Name any two radiations emitted by the sun that the are not visible to human eye.
2. Name the devices in which solar energy in harnessed directly.
3. Describe the principle of solar cell.
4. A concentrator-type solar water heater has a surface area of 5m^2 and it can reflect 80% of the incident solar radiation falling on it, while it absorbs the rest. Calculate the energy concentrated by the heater at its focus in a time period of 3hrs, if solar energy incident on its iat the rate of $0.4 \text{ KJ/m}^2\text{s}$.
5. A concentrator type solar heater having a surface area of 4 m^2 can absorb only 80% of the solar radiations incident on it, while the rest is reflected. Calculate the energy concentrated by the heater at its focus in 3 hrs, if the rate of solar energy incident on it is $0.5 \text{ KJ/m}^2\text{s}$.

SOURCES OF ENERGY

14.1 NUCLEAR FISSION :

In 1939 two German scientists Otto Hahn and Fritz Strassman very carefully analysed the products of their experiments on bombardment of uranium with neutrons. One of the products was found to be a barium isotope emitting β -rays and having a half-life of 86 minutes. This was identical to the known characteristics of ^{139}Ba . Another product of this reaction was an isotope of lanthanum ^{140}La , which has a half-life of 40 hours. The uranium atom with $Z = 92$ and atomic mass number of 235 disintegrates into atoms, whose atomic number is $Z = 56$ and atomic mass number = 139 (barium) and $Z = 57$ has atomic mass number = 140 (lanthanum). The mass of the products = $139 + 140 = 279$ u [unified atomic mass unit]. This is more than the mass of uranium nucleus and therefore only one of the two products would be produced in a given reaction. The other product would be an atomic species with atomic number of nearly 36 and atomic mass of about 100 u. Hahn and Strassman were indeed able to find active isotopes of Strontium ^{88}Sr and Yttrium ^{90}Y . In simple language they showed that the heavy uranium atoms split into lighter atoms of smaller atomic numbers. This process is named as nuclear fission.

14.1 (a) Fission Products :

Fission of uranium produces nuclei that have a mass number range from 72 [$^{72}\text{Zn}_{30}$] to mass number 158 [$^{158}\text{E}_{63}$]. Nuclei of different mass numbers can be produced by fission of uranium. Fission of $^{235}\text{U}_{92}$ yields mainly two groups of nuclei. One of the groups is a light group with atomic mass numbers in the range 85 to 140 u. The second group is a heavy group with mass numbers in the range from 130 to 149 u. Most commonly occurring products are molybdenum [$_{42}\text{Mo}$] and lanthanum [$_{57}\text{La}$]. There are some "PROMPT" and "DELAYED" categories. In the first category prompt, the uranium nucleus splits immediately when a projectile of proper energy strikes. In delayed fission, the projectile enters the nucleus and causes instability which leads to fission of the host nucleus, $^{236}\text{U}_{92}$. The fission of natural uranium and some other isotopes take place without any projectile being hit on the same.

14.1 (b) Types of Fission Reactions :

All the nuclear fission reactions can be divided into three categories :

(i) Spontaneous fission (ii) Prompt fission and (iii) Delayed fission.

(i) When a nucleus undergoes fission on its own (without being hit by a projectile like neutron), it is called spontaneous fission.

A spontaneous nuclear fission does not need to be initiated. In spontaneous nuclear fission, the natural shaking motion (or oscillations) of the nucleons in a heavy nucleus causes it to break into smaller nuclei. Spontaneous fission keeps on taking place in natural uranium all the time, but at a very-very slow rate.

(ii) When a nucleus splits up into smaller nuclei instantaneously as soon as it is bombarded with a projectile (like neutrons), it is called prompt fission. About 99 percent of the uranium - 235 fission caused by slow neutrons is prompt fission. The prompt fission is produced by prompt neutrons which are emitted instantaneously by the splitting nuclei.

(iii) When a projectile like neutron enters a nucleus and causes an instability which leads to the fission of the nucleus after a short while, it is called delayed fission. About 1 percent of the uranium - 235

fission caused by neutrons is delayed fission. The delayed fission is caused by delayed neutrons, which are emitted slowly by the splitting nuclei.

(iii) When a projectile like neutron enters a nucleus and causes an instability which leads to the fission of the nucleus after a short while, it is called delayed fission. About 1 percent of the uranium-235 fission caused by neutrons is delayed fission. The delayed fission is caused by delayed neutrons, which are emitted slowly by the splitting nuclei.

Different amount of energies are required to produce fission from one isotope to the other. There is threshold energy of projectiles below which no fission takes place.

Fission of nuclei is often accompanied by emission of neutrons that cause further fission. The fission of uranium is accompanied by 2 or 3 neutrons per fission. Energies of such neutrons lie in a wide range.

Unit of energy usually used in nuclear reactions is eV or MeV.

$$1\text{eV} = 1.6 \times 10^{-19} \text{ J}$$

$$1\text{MeV} = 1.6 \times 10^{-13} \text{ J}$$

14.1 (c) Energy Released by Fission Reaction :

Energy released in a fission reaction can be calculated by comparing the masses of nucleus which has undergone fission together with that of projectile used to cause fission and the masses of fission products.

Ex 1. Consider fission of $^{235}_{92}\text{U}$, fission takes place when it is bombarded with low energy neutrons (neutrons having an energy of about 0.025 eV). Velocity of such neutrons is about $2,200 \text{ ms}^{-1}$ which is about ten times that of modern jet plane. There are many fission reactions possible. Consider most portable reaction in which $^{95}_{35}\text{Mo}$ and $^{139}_{57}\text{La}$ is produced with emission of 2 neutrons.

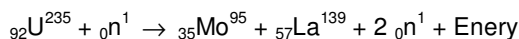

$$\text{Mass of } ^{92}_{92}\text{U}^{235} = 235.124 \text{ amu}$$

$$\text{mass of } {}^1_0\text{n} = 1.009 \text{ amu}$$

$$\text{Initial mass} = 236.133 \text{ amu} \quad (\text{i})$$

$$\text{Mass of } ^{95}_{35}\text{Mo}^{95} = 94.946 \text{ amu}$$

$$\text{Mass of } ^{139}_{57}\text{La}^{139} = 138.955 \text{ amu}$$

$$\text{Mass of } 2 {}^1_0\text{n} = 2.018 \text{ amu}$$

$$\text{Final mass} = 235.919 \text{ amu} \quad (\text{ii})$$

We find that the initial mass is more than final mass. This means that mass defect [(i) - (ii)] i.e., $236.133 \text{ u} - 235.919 \text{ u} = 0.214 \text{ u}$

We know that 1 amu or 1 u gives 931 MeV energy.

$\therefore 0.214 \times 931 = 199.234 \approx 199.22 \text{ MeV}$ of energy is released.

Ex 2. Another popular nuclear reaction of $^{235}_{92}\text{U}$ is,

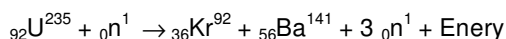

$$\text{Initial mass} = \text{mass of } ^{92}_{92}\text{U}^{235} + \text{mass of } {}^1_0\text{n} = 235.0439 + 1.0087 = 236.0526 \text{ amu}$$

$$\text{Final mass} = \text{mass of } ^{92}_{36}\text{Kr}^{92} + \text{mass of } ^{141}_{56}\text{Ba}^{141} + 3 \times \text{mass of } {}^1_0\text{n}$$

Final mass = $91.8954 + 140.9177 + 3.0261 = 235.8392 \text{ u}$
 Difference of mass = $236.0526 \text{ amu} - 235.8392 \text{ u} = 0.2134 \text{ amu}$
 But 1 amu gives 931 MeV energy.
 \therefore Energy produced = $0.213 \text{ amu} \times 931 = 198.7 \text{ MeV}$

Ex 3. Energy produced from 1 Kg of ${}_{92}^{235}\text{U}$.

We know that 235 g of ${}_{92}^{235}\text{U}$ contains 6.023×10^{23} atoms

$$\text{Number of atoms in 1Kg of } {}_{92}^{235}\text{U} = \frac{6.023 \times 10^{23}}{235} \times 100 \text{ atoms.}$$

$$= 25.63 \times 10^{23} \text{ atoms}$$

If one atom releases 200 MeV of energy, then energy released by 1Kg of ${}_{92}^{235}\text{U} = 25.63 \times 10^{23} \times 200 \text{ MeV}$

$$\begin{aligned} &= 5.126 \times 10^{23} \text{ MeV} \\ &= 5.126 \times 10^{23} \times (1.6 \times 10^{-13}) \\ &= 8.2014 \times 10^{10} \text{ J} = 8.201 \times 10^{10} \text{ J} \end{aligned}$$

This is the energy produced by burning 2,500 tons of coal.

14.1 (d) Process of Nuclear Fission :

The process of nuclear fission is explained by the 'Liquid drop model' of the nucleus. The liquid drop model of the nucleus to explain the process of fission was proposed by Yakov Frenkel, Neils Bohr and John Wheeler. According to the liquid drop model of the nucleus it is said that is just the same way that a drop of water might become unstable if another small drop hits it, the uranium nucleus becomes unstable and breaks up when hit by a neutron. In this model, the uranium nucleus is treated like a drop of a liquid, which is not compressible and has a uniform positive charge. It is imagined that a stretchable skin-like membrane surrounds the drop like nucleus and holds all the protons and neutrons together inside its body. In the stable stage, the uranium nucleus, like a drop of water is spherical in shape. The nuclear fission of uranium - 235 isotope by means of a slow moving neutron can be explained diagrammatically as follows :

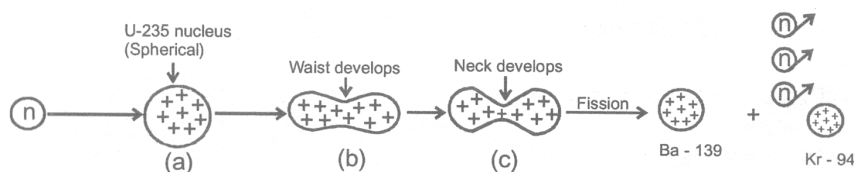
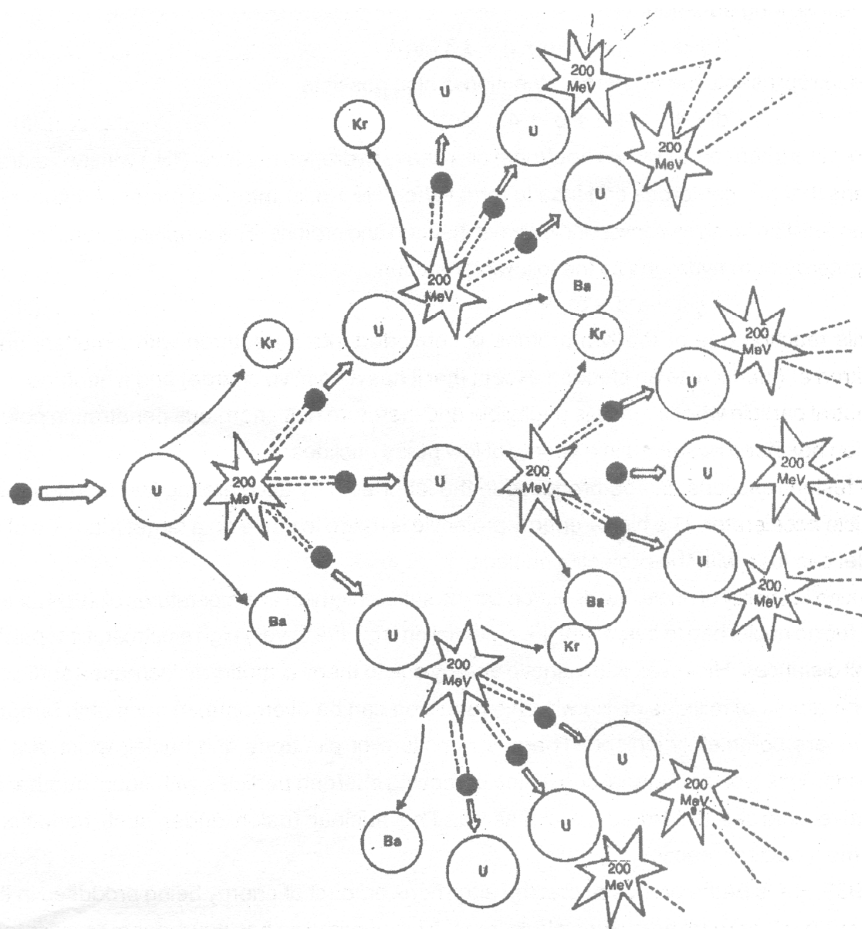

Figure (a) shows that uranium nucleus to be spherical. In this spherical nucleus the nuclear particles like protons and neutrons are very close together because of which the nuclear force of attraction and the electrostatic force of repulsion are very delicately balanced. Now, when a slow moving neutron attacks the uranium - 235 nucleus and enters into it, then the delicate balance of force inside the nucleus is disturbed. The energy of neutron is transferred to the nucleons (protons and neutrons) and by gaining this energy, the nucleons start oscillating more and more. Due to increased oscillations of the nuclear particles, the skin-like outer membrane of the nucleus gets stretched, the nucleus gets elongated and a waist develops in it. When the nucleus gets elongated then the distances between nuclear particles (protons and neutrons) increase. This increased inter-particle distance weakens the nuclear force of attraction so that the electrostatic force of repulsion becomes more dominant. Due to the increased repulsion between the protons, a neck develops in the nucleus as shown. The formation of neck decreases the nuclear force further. And the increased repulsion between protons ultimately leads to the breaking up of the uranium - 235 nucleus to form two smaller nuclei if barium - 139 and krypton-94, along with the emission of three neutrons.

14.7 (e) Chain reaction :

A reaction in which the particle which initiates (starts) the reaction is also produced during the reaction to carry on the reaction further and further is called a chain reaction. Once started a chain reaction will go on propagating by itself, until one of the reactant is all used up. The fission of uranium-235 by means of slow moving neutrons is a chain reaction, because this reaction is started by neutrons and neutrons are also produced during this reaction. The neutrons produced during the fission of a uranium atom initiate the fission of more uranium atoms, and this process goes on, like an unending chain, with the liberation of a large amount of energy at each step. The chain reaction taking place during the fission of uranium - 235 can be represented more clearly with the help of a diagram.



The fact that only 1 neutron is used up in each fission process but 3 neutrons are produced, makes the fission process in uranium - 235 a self-sustaining process or self-propagating process called chain reaction. If on the other hand on an average less than 1 neutron had been produced per fission, then the reaction would have died down like a fire in a wet fuel. It should be noted that a chain reaction involves a large number of uranium atoms. So, a chain reaction cannot occur in a very small lump of uranium - 235 isotopes, but it can take place in a sufficiently large mass of uranium - 235 isotopes. The minimum mass of uranium - 235 atoms or any other fissionable material which can support a chain reaction is called critical mass of that material.

14.2 NUCLEAR FUSION :

Under special conditions, it is possible that nuclei of light elements can combine to form a nucleus of higher atomic number. For example, two deuterons can join together to form a ${}^3\text{He}$ nucleus plus a neutron. The deuteron (D) is the heavy hydrogen nucleus (${}^2\text{H}_1$) consisting of one proton and one neutron. In simple language, two heavy hydrogen nuclei can combine to form a nucleus of helium (${}^3\text{He}$). This process, in which nuclei of low atomic numbers combine to form a heavier atomic nucleus, is known as nuclear fusion. The fusion reaction is also accompanied by release of energy, like the fission phenomena. Fusion was discovered nearly 70 years ago in 1930. The typical fusion reaction mentioned above can be represented by the following equation :

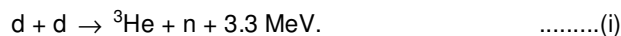

Here, d represents the deuteron. Reaction is also possible:



Here, t is a triton (proton + two neutrons) or a heavy hydrogen nucleus (${}^3\text{H}_1$) with two extra neutrons. This means that two deuterons can fuse to form either ${}^3\text{He} + n$, or triton + a proton. Another type of important fusion reaction involves conversion between neutron and protons. The simplest among these is the synthesis of deuteron from hydrogen by the following reaction :



In this reaction one of the two protons is converted into a deuteron with simultaneous creation of a positron e^+ (identical to an electron except that it has a positive charge) and a neutrino ν . The neutrino is a neutral particle whose mass is negligible and therefore has enormous penetrating power.

Fusion has been observed in a variety of low mass nuclides.

The fusion reactions can be produced in the laboratory by accelerating low atomic number nuclei in a particle accelerator. The high - energy projectile is made to strike on a target made up of material whose nuclei can fuse with the projectile nucleus.

The kinetic energy of nuclei like deuteron can be sufficiently high at temperatures of 10^6 K for the nuclei to fuse. The fusing nuclei had to overcome the potential energy due to very high electrostatic repulsion at extremely small distance. However, if the kinetic energy due to thermal motion is increased sufficiently at elevated temperatures of millions of Kelvin, this repulsion can be overcome. At such high temperatures, all the atoms are completely ionised. There is a mixture of electrons and nuclei, which are moving at high speeds. This type of material consisting of moving charged particles with equal number of negative and positive charges is termed as a plasma. The nuclear fusion under such conditions is termed as thermo - nuclear reaction.

In 1939, Hans Bethe proposed that the enormous amount of energy being produced in the sun is due to thermo-nuclear reactions taking place there. This hypothesis has now become universally accepted.

14.2 (a) Secret of Sun's Energy :

The sun is a huge mass of hydrogen gas and the temperature in it is extremely high.

In the sun the small deuterium atoms (isotope of H atom) collide and fuse together to form bigger atoms of helium. Each time an atom of helium is formed, tremendous energy is released in the form of heat and light. It is this energy which makes the sun shine. The main reaction taking place in sun is -

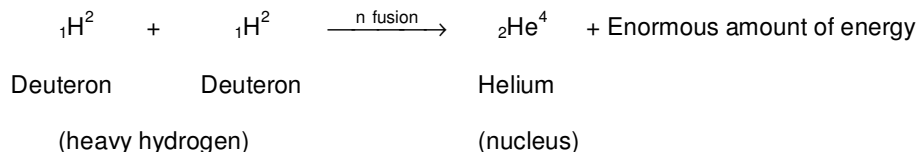

Sun also contains two other isotopes of H: ordinary H, ${}^1\text{H}_1$ (called protium) and very heavy hydrogen ${}^3\text{H}_1$ (called tritium).

These two also fuse with deuterium to form helium nucleus and release energy. Thus two more reaction taking place in sun are

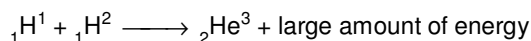

Protium Deuteron Helium



Deuterium Tritium

(Heavy H) (Very heavy H)

Nuclear fusion reactions of various isotopes of hydrogen to form helium are going on inside the sun that produces such a great amount of energy which is radiated by the sun. Because of this energy, sun emits radiations (light) of different wavelengths of all the sun's radiation. It is the infra - red radiations which carry heat energy and hence heat up the earth.

14.2 (b) Hydrogen Bomb :

The nuclear fusion is the basis principle involved in the preparation of hydrogen bomb.

A hydrogen bomb is actually an uncontrolled nuclear fusion process.

A hydrogen bomb consists of a arrangement of nuclear fission in the centre. It is surrounded by a mixture of deuteron ${}^2\text{H}_1$ and lithium - 6 isotope (${}^6\text{Li}_3$).

The nuclear fission provides heat and neutrons. The neutrons are used in converting lithium isotope into tritium ${}^3\text{H}_1$ and the heat liberated is required for the fusion between ${}^1_1\text{H}^2$ and ${}^1_1\text{H}^3$ to start. The fusion reactions are then accompanied by the liberation of a large amount of energy.

Note : The nuclear fusion reaction occur at very high temperature, so they are also known as thermonuclear reactions.

The reactions are :

Fission (in the centre) $\xrightarrow{\text{produce}}$ heat + neutrons

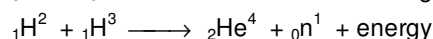

(Deuterium) (tritium)

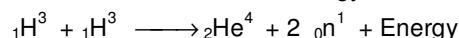
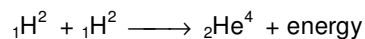

(Note : - Tritium has to be prepared within the hydrogen bomb because it is not stable)

14.3 DIFFERENCE BETWEEN NUCLEAR FISSION AND NUCLEAR FUSION :

Nuclear fission	Nuclear Fusion
1. It is confined to heavy nuclei only.	1. It is confined to lighter nuclei.
2. A heavy nucleus splits into two lighter nuclei.	2. To lighter nuclei fuse to form a heavy nucleus.
3. It is a chain reaction.	3. it is not a chain reaction.
4. Temperature required for the reaction is not high.	4. It is thermo nuclear reaction i.e. it required high temperature
5. Fission reaction can be controlled.	5. Fusion reaction is very difficult to control.
6. Large amount of energy is released.	6. Energy released is far more that released in a fission reaction.
7. Large number of radioactive products are obtained i.e. large amount of nuclear waste is left.	7. No nuclear waste is left.

DAILY PRACTICE PROBLEMS # 14

OBJECTIVE DPP - 14.1

- The device in which the nuclear fission and release of energy is controlled, is known as :
 (A) Thermopile (B) Thermostat (C) Nuclear reactor (D) Cloud chamber
- For a sustained chain reaction, the reproduction factor should be :
 (A) zero (B) one (C) two (D) three
- Moderator is used in nuclear reactor for :
 (A) slowing neutrons (B) accelerating neutrons
 (C) stopping neutrons (D) heating the neutrons
- The fusion reaction occur at :
 (A) low pressures (B) low temperature
 (C) extremely high temperature (D) high temperature and low pressures
- The source of energy of the sun is :
 (A) Nuclear fission (B) Chemical reaction (C) Nuclear fusion (D) None of these

6. The number of neutrons in an atom X of atomic number Z and mass number A is :-
 (A) zero (B) Z (C) A - Z (D) A
7. When a beta particle is given out, the atomic number of the parent atom :
 (A) Increase by unity (B) Decrease by unity (C) Remains the same (D) Is halved
8. Which of the following has least penetrating power ?
 (A) Alpha particles (B) Gamma rays
 (C) Beta particles (D) All have the same penetrating power

SUBJECTIVE DPP - 14.2

- Differentiate between nuclear fission and nuclear fusion.
- Define nuclear fusion reaction. Describe the conditions for the occurrence of a nuclear fusion reaction.
- It is said that energy from nuclear fusion would create fewer pollution problems than energy from fission. Can you give reason, why ?
- 48 k J energy is produced in 60 s in a nuclear reactor. Find the number of fissions which would be taking place per second if the energy released per fission is 3.2×10^{-11} J.

ANSWER

Objective DPP 13.2

Q.	1	2	3	4	5	6	7	8	9	10	11	12
A.	D	A	D	C	C	B	D	C	D	A	A	C

Subjective DPP 13.2

4. 2880 KJ 5. 17280 KJ

Objective DPP 14.1

Q.	1	2	3	4	5	6	7	8
A.	C	B	A	C	C	C	A	A

Subjective DPP 14.2

4. 25×10^{12} fissions