

A&L
ALLEC & LANE MANUFACTURING

**PERFORMANCE PRODUCTS
THAT MAKE A WINNING DIFFERENCE**

- **86-87** Trinity Shootout 2 Wheel Modified T.O. Chris Allec
- **86** Roar 2 Wheel Modified National Champion Chris Allec
- **87** Reedy Race of Champions Invitational Class Champion Chris Allec
- **87** Roar Region 6, 2 Wheel Stock Class Winner Kurtis McElroy
- **88** Reedy Race 2 Wheel Modified T.O. Kurtis McElroy
- **88** Cactus Classic 2 Wheel Modified Winner Kurtis McElroy
- **88** Reedy Race Invitational 2 Wheel T.O. Chris Allec

PRO RACING
A&L CONVERSION
KIT INSTRUCTIONS
Part# G10120



KEEP AN EYE ON US FOR YOUR PERFORMANCE MINDED RACING NEEDS

ALLEC & LANE MANUFACTURING

G10120 & G10130 A & L REAR SUSPENSION INSTRUCTIONS FOR ASSEMBLY

APPLICABLE TO A & L GRAPHITE ULTIMA OR RC 10 CHASSIS

1. Mount your existing front suspension, steering linkage, gearbox and A & L front and rear bumper. Chassis are designed to use RC10 battery trays. The rear battery tray must be cut down to 1/2 inch in width (Ultima cars only) and be mounted upside down. The front battery tray does not need to be cut down.

RC10 chassis only: Bulkhead ears must be cut off and bottom rear cut out for the inside suspension hinge post (see Figure A). Motor plate must be cut off for rear bumper (see Figure F).

Ultima chassis only: Front bottom of shock tower bulkhead must be cut off for clearance of batteries (see Figure B). Rear bulkhead requires drilling of two holes (size 38 - 40) for mounting of rear bumper.

2. Mount A & L shock tower onto bulkhead. Then mount A & L shock blocks, body mount and wing mounts to shock tower (see Figure E).
3. Mount suspension hinge post to the toe-in adaptor plates (see Figure C). Note: the posts are at different heights with the shorter post going inboard. Also note hinge pin holes are drilled at an angle in the post. We recommend that you start off by using the 3° toe-in plates (see Figure D). Loosely mount the outside tall post to the outside countersunk hole of the toe-in plate. Temporarily mount the inside short post to the toe-in plate. Now take the hinge pin and slide it through the outside eye of the trailing arm and then through the outside mounting post. Next take a circlip and install on the outside hinge pin groove and then a shim next to it. Slide the pin through the inside eye of the trailing arm and install another shim and circlip. Check the arm for freeplay between circlips, slightly file arm for clearance if needed. Now slide the hinge pin and arm through the inside post. Loosely tighten the inside post (this screw will have to be taken out later to go through the bottom of the chassis) and completely tighten the outside post that is countersunk in the toe-in plate.
4. Install bearings into the arm (bearings are a press fit) using a socket or nut driver the same size as the outside of the bearing and press them straight into the arms. Now install axles into the arms, stock axle and dogbones, or the various universals will work with our kit. Note that the axle lengths and sizes will vary between manufacturers (shimming may be required).
5. Remove the inside post screw from the toe-in plate and mount the arm assembly onto the chassis using the inside post hole and the hole inside of the outside post (see Figure C).
6. Slide the arm assembly in as close as possible but not enabling the dogbone to bind against the inside end of the drive cups. Once the dogbone play is set, install set screws into the top of the post with locktite.
7. Install shock onto arm, note it is necessary to use only a stock RC10 shock ball and plastic pivot eye for proper shock mounting into A & L trailing arm. Use supplied 3mm x 14mm button heads for shock mounting at top and bottom. The RC10 shock ball mounts into A & L arm with flanged end going towards the wheel. Use a piece of rubber tubing for mounting the top of shock over the 3mm x 14mm button head.
8. We recommend to run the car with a maximum travel giving the car 1-1/2 inches of ground clearance and with a race ready ride height of one inch. Put limiters in the shocks to stop the downward travel of arms at the 1-1/2 inch of ground clearance. Hard plastic tubing is recommended for limiting shock travel. Do not allow arms' downward travel to be stopped by hitting mounting posts or adaptor plate as this may cause breakage.

SCREWS — HOW MANY — WHERE THEY GO

- | | | | |
|---|--------------------------------------------------------|---|----------------------------------|
| 4 | 3mm x 6mm Wing Mounts and Rear Body Mount Block | 2 | 4mm x 12mm Toe-In Plate |
| 6 | 3mm x 8mm Shock Blocks to Shock Tower and Front Bumper | 8 | 1/8 Shims for Hinge Pins |
| 1 | 3mm x 10" Rear Body Post | 6 | 1/8 Circlips for Hinge Pins |
| 4 | 3mm x 14mm Shock Mounting Upper & Lower | 2 | 4mm Nylock Nuts for Toe-In Plate |
| 6 | 3mm x 3mm Set Screws / Wing Mount & Mounting Post | 2 | 3mm Nylock Nuts Front Bumper |
| 2 | 4mm x 8mm Outside Hinge Post | 2 | 4-40 x 1/4 Rear Bumper |
| 2 | 4mm x 10mm Inside Hinge Post | 2 | 4-40 T-Nuts Rear Bumper |

A & L PARTS LIST FOR A & L GRAPHITE ULTIMA (G10120) AND RC10 (G10130) CHASSIS

PART	(RC10 ONLY)	PART NUMBER	QUANTITY	PRICE
RC10 Chassis Kit		G10130	Kit	197.75
RC10 Graphite Chassis Only		G10030	1	79.95
Right Trailing Arm		R101	1	17.95
Left Trailing Arm		L102	1	17.95
R & L Trailing Arm		RL103	1 ea.	35.90
Rear Shock Tower (Graphite)		12001	1	13.95
Front Bumper		3013	1	3.95

(ULTIMA ONLY)

Ultima Chassis Kit		G10120	Kit	219.95
Ultima Graphite Chassis Only		G10020	1	79.95
Right Trailing Arm		R104	1	18.95
Left Trailing Arm		L105	1	18.95
R & L Trailing Arm		RL106	1 ea.	37.90
Rear Shock Tower (Graphite)		12020	1	13.95
Front Bumper		3012	1	3.95
5 x 10 Flanged Bearings		5000	2	10.00
Kyosho to Kyosho Wheel Adaptors		1030	2	8.95

(ULTIMA & RC10)

Mounting Post Long & Short		1009	1 ea.	7.95
Shock Mounts		3002	2 ea.	5.90
Body Mount Kit		3100	1	4.50
Hinge Pins		4200	2 ea.	3.95
Hinge Pin Clips		4002	1 pkg.	1.95
Hinge Pin Shims		4003	1 pkg.	1.95
Screws & Nuts		4104	set	8.95
Hex Wrenches		4101	set	2.25
Wing Mounts		1004	2	6.95
Body Post		1005	1	1.75
Adjustable Toe-In Plates 1° - 5°		2025	2 ea.	10.95
Rear Bumper		3011	1	7.95

ULTIMA OPTIONAL PARTS

Front Shock Tower Graphite		12021	1	13.95
Front Shock Tower Fiberglass		2021	1	6.95
Front Body Mount		3110	1	3.50

RC10 OPTIONAL PARTS

Kyosho to RC10 Wheel Adaptors		1020	2	9.95
-------------------------------	--	------	---	------

**THANK YOU FOR USING OUR PARTS!
GOOD RACING**

Chris Allec and Daryl Lane

FIGURE A

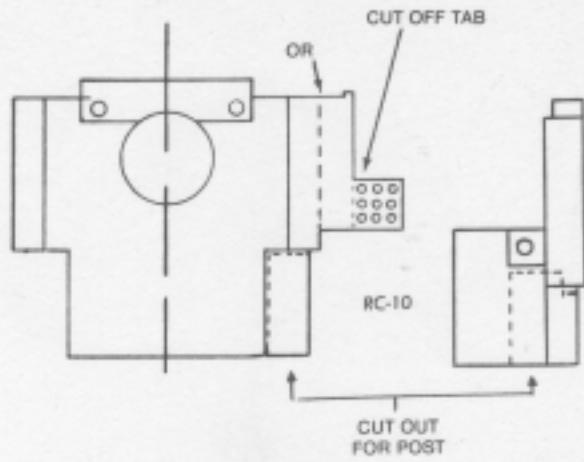

FIGURE C

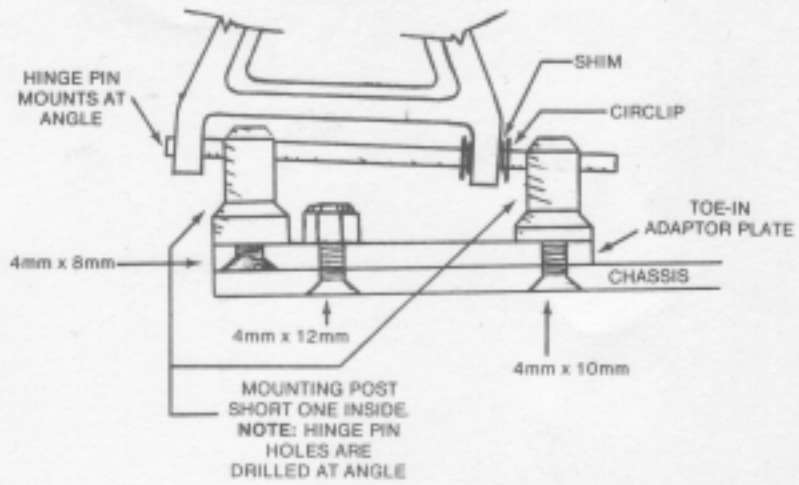

FIGURE B

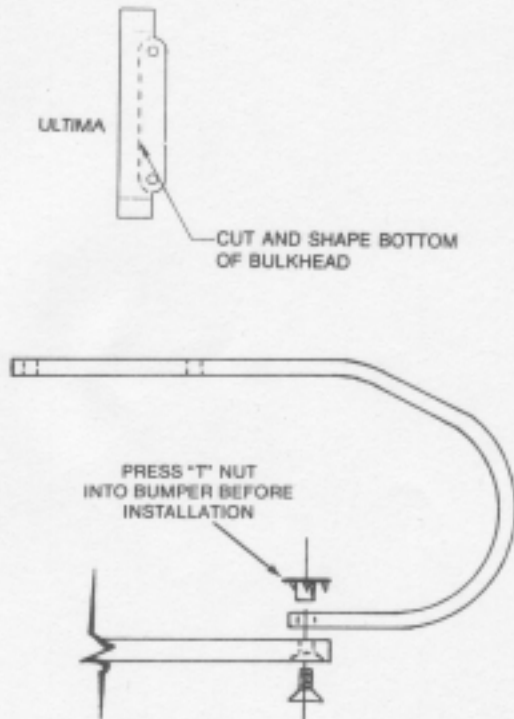

FIGURE D

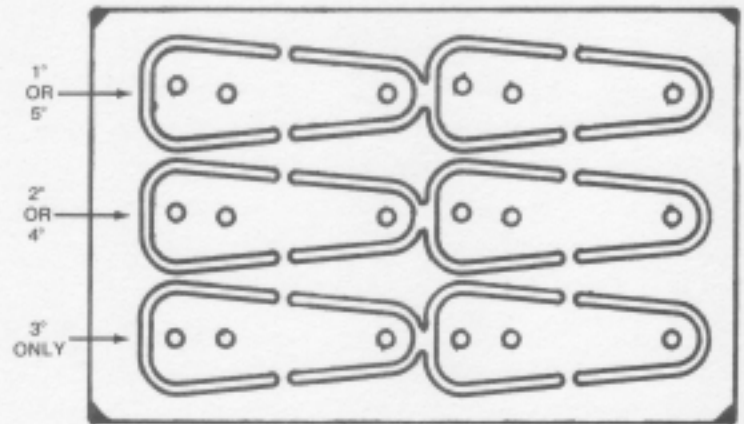
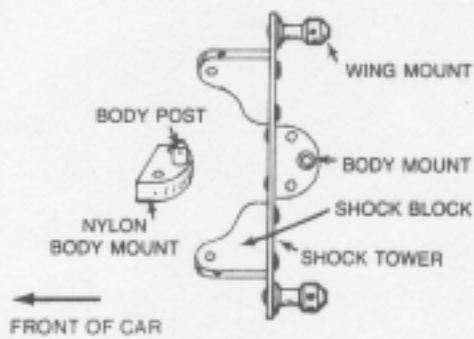

FIGURE E

SHOCK TOWER ASSEMBLY TOP VIEW



CUT OFF HORIZONTAL BRACE

FIGURE F

