

FUEGO

# Grills | Griddles | Pizza Oven



## KEY FEATURES

### Performance

- Dual Infrared Burners
- Combined 35,000 BTU/hr
- 400 sq. in. of total grilling surface
- Overall temperatures range from 300F to 750F
- 15 Minute Preheat Time

### Features & Benefits

- All 304 Stainless Steel Construction
- Reversible Top Vent
- Fully Assembled Packaging
- Pizza | Baking | Roasting
- Push Button Electronic Ignition
- NG and LP Options Available
- Limited Lifetime Warranty

### Optional Accessories

- FSAOC4 - Outdoor Cover (3 Color Choices)
- FSAPP1 - Pizza Peel



Sleek Design



Dual Infrared Burners



Reverseable Top Vent



All 304 SS Construction



Pizza



Roasting



Baking



Limited Lifetime Warranty



## TECHNICAL SPECS

|                                   |  |
|-----------------------------------|--|
| <b>Dimensions:</b>                | 27" W   24" D   27" H                            |
| <b>Package Dimensions:</b>        | 34" W   30" D   34" H                            |
| <b>Package Weight:</b>            | 155 Pounds                                       |
| <b>Gas Requirements:</b>          | 35,000 BTU/hr<br>Natural Gas and Propane Options |
| <b>Grill Type:</b>                | Table Top  |
| <b>Clearance To Combustibles:</b> | Sides: 24"<br>Rear: 24"<br>Floor: None           |

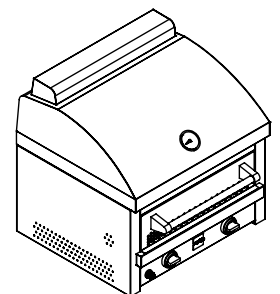
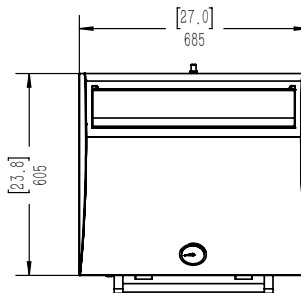
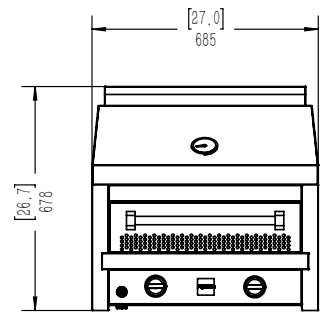
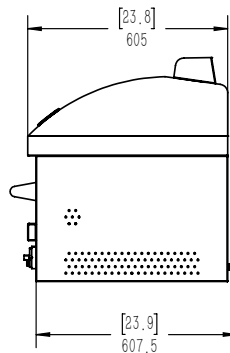

## KEY FEATURES

### Performance

- Three U Shaped 304 SS Burners
- Rear Infrared Rotisserie Burner
- Combined 72,500 BTU/hr
- 865 sq. in. of total grilling surface
  - 685 sq. in. main grilling area
  - 180 sq. in. warming rack
- Overall temperatures range from 250F to 650F
- Heats up to 500F in just 5 minutes

### Benefits

- All 304 Stainless Steel Construction
- Fully Assembled Packaging
- Completely Welded Firebox
- Recessed Foldable Shelves For Compact Footprint
- Push Button Electronic Ignition
- Easy-To-Clean Hidden Residue Tray
- Heavy Duty 8mm Solid 304SS Cooking Grates
- Interior Halogen Lights
- NG and LP Options Available
- Limited Lifetime Warranty

### Optional Accessories

- FSAOC2 - Outdoor Cover (3 Color Choices)
- FSAGP1 - Griddle Plate
- FSACT1 - Charcoal Tray
- FSART1 - Rotisserie Kit

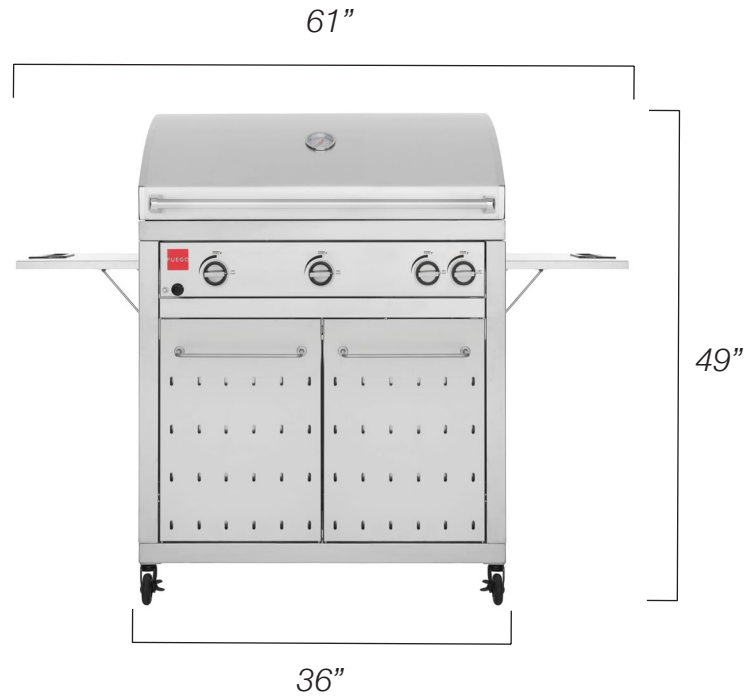

Interior Halogen Lights



Premium Burners



Recessed Side Shelves



All 304 SS Construction

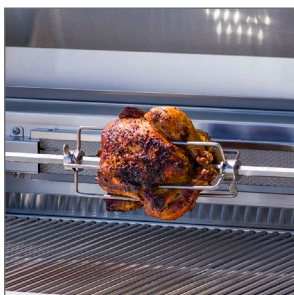

Rear Infrared Burner



Griddle Plate



Charcoal Grilling



Traditional Grilling



## TECHNICAL SPECS

|                                   |   |
|-----------------------------------|---|
| <b>Dimensions:</b>                | 36" W   24" D   47" H (Lid Closed)<br>36" W   29" D   47" H (Lid Open)  |
| <b>Package Dimensions:</b>        | 41" W   30" D   52" H   |
| <b>Package Weight:</b>            | 230 Pounds  |
| <b>Gas Requirements:</b>          | 72,500 BTU/hr - Total Output<br>60,000 BTU/hr - Main Burners<br>12,500 BTU/hr - Rear IR Burner<br>Natural Gas and Propane Options |
| <b>Electrical Requirements</b>    | 120V/15GFI Electrical Outlet  |
| <b>Grill Type:</b>                | Freestanding  |
| <b>Clearance To Combustibles:</b> | Sides: 24"<br>Rear: 24"   |

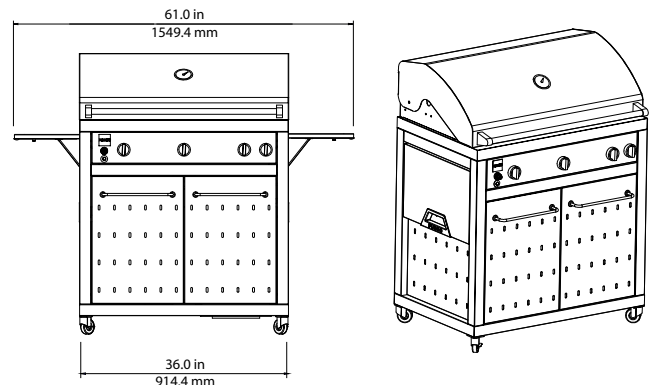
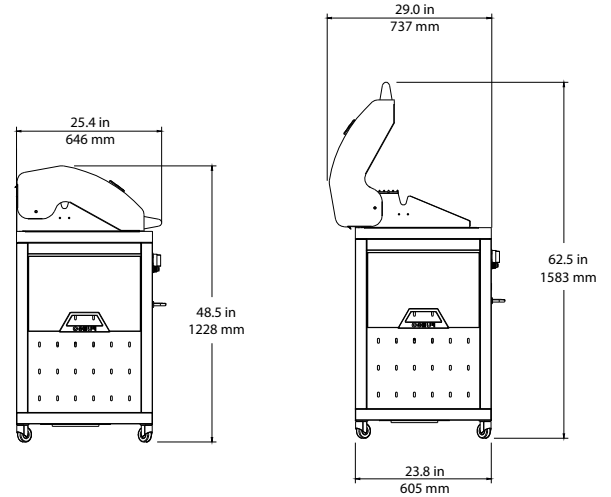

## KEY FEATURES

### Performance

- Three U Shaped 304 SS Burners
- Combined 60,000 BTU/hr
- 865 sq. in. of total grilling surface
  - 685 sq. in. main grilling area
  - 180 sq. in. warming rack
- Overall temperatures range from 250F to 650F
- Heats up to 500F in just 5 minutes

### Benefits

- All 304 Stainless Steel Construction
- Fully Assembled Packaging
- Completely Welded Firebox
- Recessed Foldable Shelves For Compact Footprint
- Push Button Electronic Ignition
- Easy-To-Clean Hidden Residue Tray
- Heavy Duty 8mm Solid 304SS Cooking Grates
- 3-In-1 Cooking - Grilling | Griddle | Charcoal
- NG and LP Options Available
- Limited Lifetime Warranty

### Optional Accessories

- FSAOC2 - Outdoor Cover (3 Color Choices)
- FSAGP1 - Griddle Plate
- FSACT1 - Charcoal Tray
- FSART1 - Rotisserie Kit

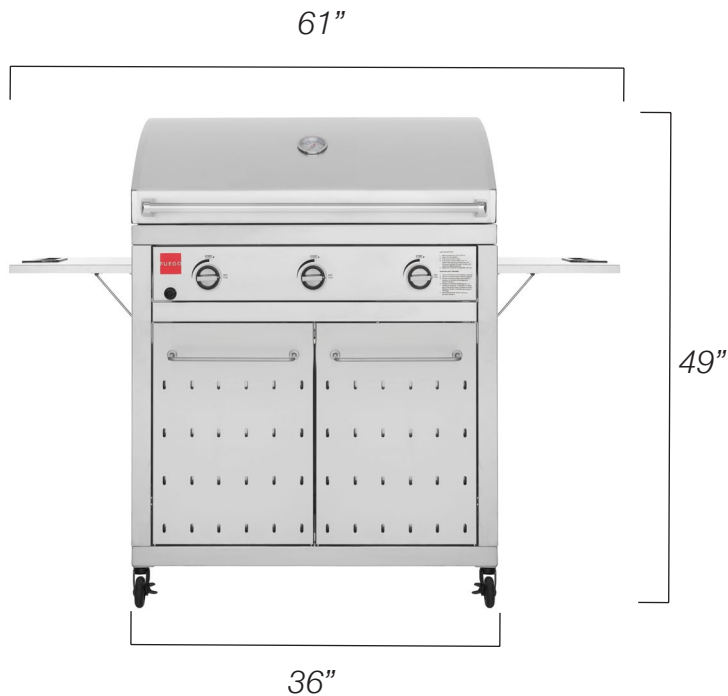

Hidden Residue Tray



Premium Burners



Recessed Side Shelves



Heavy Duty 8mm Grates



Traditional Grilling

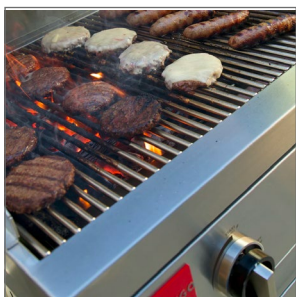

Charcoal Grilling



Griddle Plate



All 304 SS Construction



## TECHNICAL SPECS

- Dimensions:** 36" W | 24" D | 47" H (Lid Closed)  
36" W | 29" D | 62.5" H (Lid Open)
- Package Dimensions:** 41" W | 30" D | 52" H
- Package Weight:** 212 Pounds
- Gas Requirements:** 60,000 BTU/hr  
Natural Gas and Propane Options
- Grill Type:** Freestanding
- Clearance To Combustibles:** Sides: 24"  
Rear: 24"

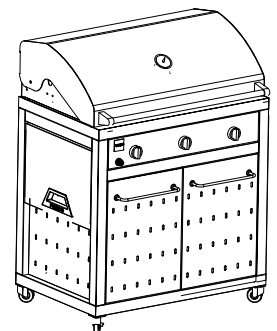
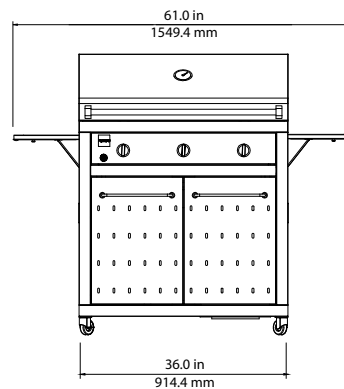
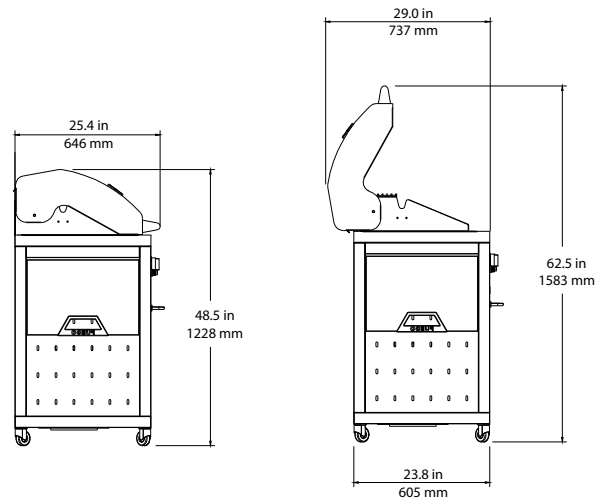

KEY FEATURES

Performance

- Two U Shaped 304 SS Burners
- Combined 40,000 BTU/hr
- 645 sq. in. of total grilling surface
  - 510 sq. in. main grilling area
  - 135 sq. in. warming rack
- Overall temperatures range from 250F to 650F
- Heats up to 500F in just 5 minutes

Features & Benefits

- All 304 Stainless Steel Construction
- Fully Assembled Packaging
- Completely Welded Firebox
- Recessed Foldable Shelves For Compact Footprint
- Push Button Electronic Ignition
- Easy-To-Clean Hidden Residue Tray
- Heavy Duty 8mm Solid 304SS Cooking Grates
- 3-In-1 Cooking - Grilling | Griddle | Charcoal
- NG and LP Options Available
- Limited Lifetime Warranty

Optional Accessories

- FSAOC1 - Outdoor Cover (Two Color Choices)
- FSAGP1 - Griddle Plate
- FSACT1 - Charcoal Tray
- FSART1 - Rotisserie Kit

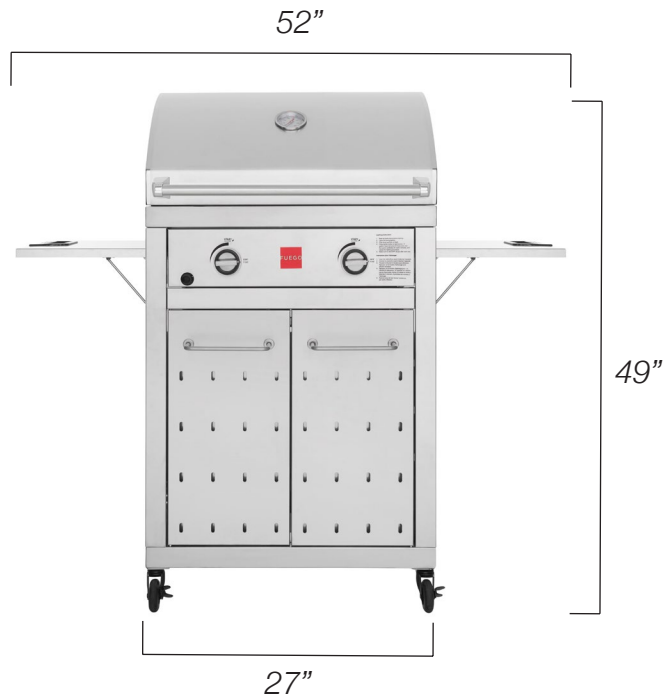

Hidden Residue Tray



Premium Burners



Recessed Side Shelves

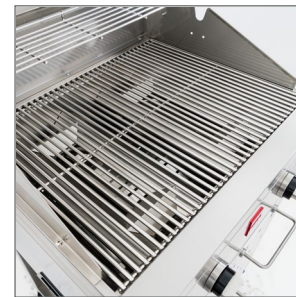

Heavy Duty 8mm Grates



Traditional Grilling



Charcoal Grilling



Griddle Plate



All 304 SS Construction





## TECHNICAL SPECS

|                                   |  |
|-----------------------------------|--|
| <b>Dimensions:</b>                | 27" W   24" D   47" H (Lid Closed)<br>27" W   29" D   62.5" H (Lid Open) |
| <b>Package Dimensions:</b>        | 34" W   30" D   52" H  |
| <b>Package Weight:</b>            | 180 Pounds   |
| <b>Gas Requirements:</b>          | 40,000 BTU/hr<br>Natural Gas and Propane Options                         |
| <b>Grill Type:</b>                | Freestanding   |
| <b>Clearance To Combustibles:</b> | Sides: 24"<br>Rear: 24"  |

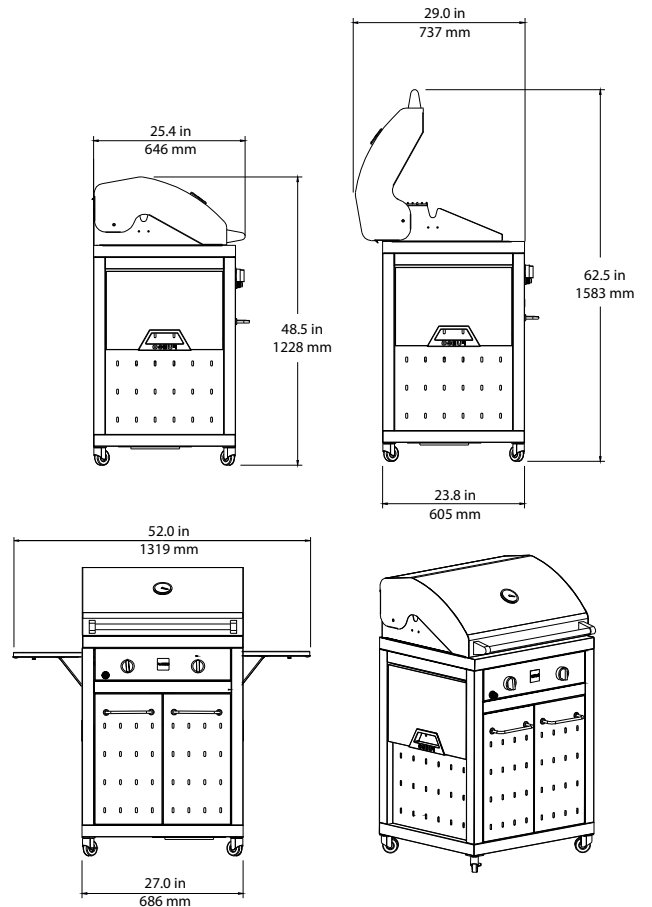

## KEY FEATURES

### Performance

- Two U Shaped 304 SS Burners
- Combined 40,000 BTU/hr
- 400 sq. in. griddle surface
- Overall temperatures range from 300F to 600F
- Heats up to 400F in just 5 minutes

### Features & Benefits

- All 304 Stainless Steel Construction
- Fully Assembled Packaging
- Completely Welded Firebox
- Recessed Foldable Shelves For Compact Footprint
- Push Button Electronic Ignition
- Easy-To-Clean Hidden Residue Tray
- Heavy Duty 8mm Solid 304SS Cooking Griddle
- Easy To Remove Griddle Top Cover
- NG and LP Options Available
- Limited Lifetime Warranty

### Optional Accessories

- FSAOC3 - Outdoor Cover (3 Color Choices)

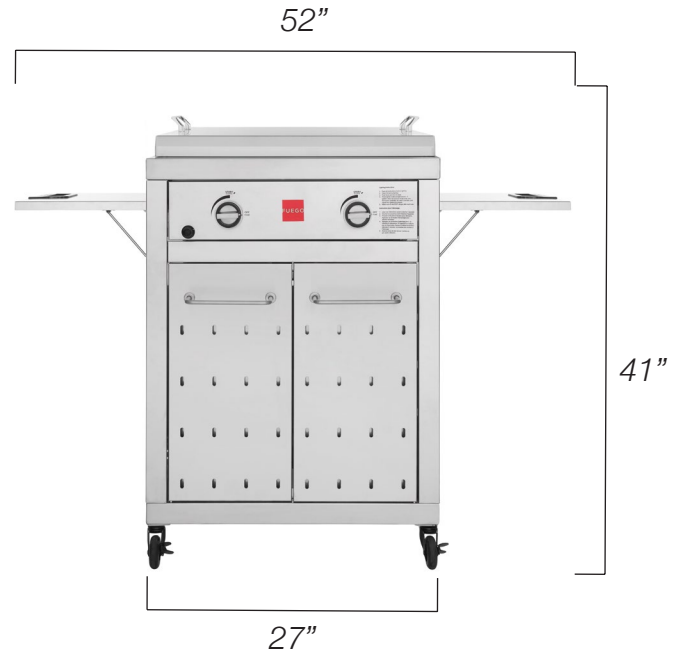

Hidden Residue Tray



Premium Burners



Recessed Side Shelves



Heavy Duty 8mm Griddle



Griddle Top Cover

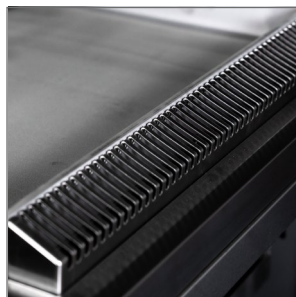

Rear Top Vents



Meat, Veggies & More

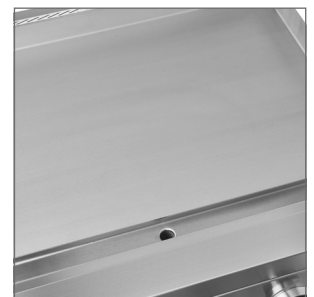

Drop Through Residue Tray



## TECHNICAL SPECS

|                                   |  |
|-----------------------------------|--|
| <b>Dimensions:</b>                | 27" W   24" D   41" H                            |
| <b>Package Dimensions:</b>        | 34" W   30" D   52" H                            |
| <b>Package Weight:</b>            | 189 Pounds                                       |
| <b>Gas Requirements:</b>          | 40,000 BTU/hr<br>Natural Gas and Propane Options |
| <b>Grill Type:</b>                | Freestanding                                     |
| <b>Clearance To Combustibles:</b> | Sides: 24"<br>Rear: 24"                          |

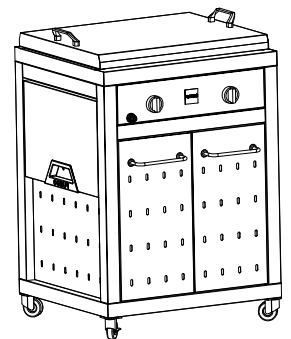
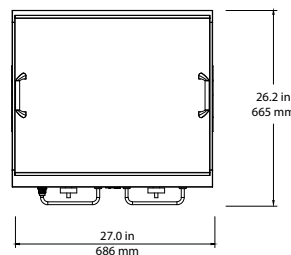
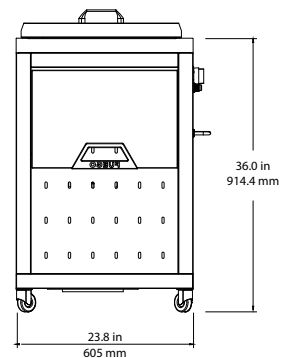
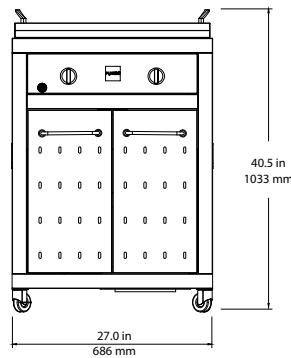

## KEY FEATURES

### Performance

- Three U Shaped 304 SS Burners
- Rear Infrared Rotisserie Burner
- Combined 75,000 BTU/hr
- 865 sq. in. of total grilling surface
  - 685 sq. in. main grilling area
  - 180 sq. in. warming rack
- Overall temperatures range from 250F to 650F
- Heats up to 500F in just 5 minutes

### Benefits

- All 304 Stainless Steel Construction
- Fully Assembled Packaging
- Completely Welded Firebox
- Push Button Electronic Ignition
- Easy-To-Clean Hidden Residue Tray
- Heavy Duty 8mm Solid 304SS Cooking Grates
- Interior Halogen Lights
- NG and LP Options Available
- Limited Lifetime Warranty

### Optional Accessories

- FSAOC6 - Outdoor Cover (3 Color Choices)
- FSAGP1 - Griddle Plate
- FSACT1 - Charcoal Tray
- FSART1 - Rotisserie Kit



Interior Halogen Lights



Premium Burners



Sleek Front Panel Design



Easy Mount Side Brackets



Rear Infrared Burner



Traditional Grilling



Charcoal Grilling



Griddle Plate



## TECHNICAL SPECS

|  |   |
|--|---|
| <b>Dimensions:</b>                     | 36" W   24" D   23" H (Lid Closed)<br>36" W   29" D   36" H (Lid Open)  |
| <b>Package Dimensions:</b>             | 34" W   30" D   32" H   |
| <b>Package Weight:</b>                 | 153 Pounds  |
| <b>Gas Requirements:</b>               | 72,500 BTU/hr<br>Natural Gas and Propane Options  |
| <b>Electrical Requirements:</b>        | 120V AC   60Hz  |
| <b>Grill Type:</b>                     | Built-In  |
| <b>Clearance To Combustibles:</b>      | Sides: 24"<br>Rear: 24"   |
| <b>Cutout Dimensions</b>               | Width: 36 3/8" (A)<br>Depth : 23 7/8" (B)<br>Height: 11 1/8" (C)  |
| <b>Island Dimensions (Recommended)</b> | Depth: 30" (D)<br>Height: 36" (E)   |
| <b>Mounting Brackets</b>               | Each built-in grill comes with a set of mounting brackets that allows the unit to suspend on top of the countertop opening for a flush mount look and feel. |

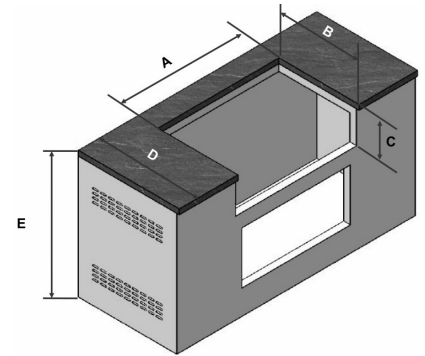
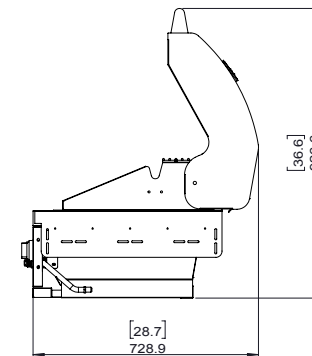
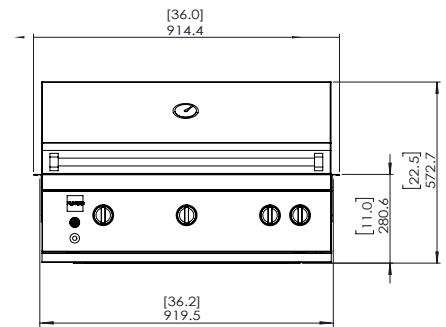
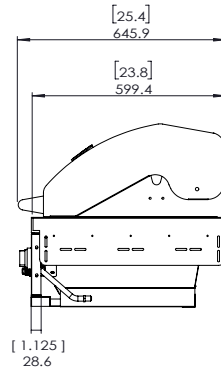

## KEY FEATURES

### Performance

- Three U Shaped 304 SS Burners
- Combined 60,000 BTU/hr
- 865 sq. in. of total grilling surface
  - 685 sq. in. main grilling area
  - 180 sq. in. warming rack
- Overall temperatures range from 250F to 650F
- Heats up to 500F in just 5 minutes

### Benefits

- All 304 Stainless Steel Construction
- Fully Assembled Packaging
- Completely Welded Firebox
- Push Button Electronic Ignition
- Easy-To-Clean Hidden Residue Tray
- Heavy Duty 8mm Solid 304SS Cooking Grates
- 3-In-1 Cooking - Grilling | Griddle | Charcoal
- NG and LP Options Available
- Limited Lifetime Warranty

### Optional Accessories

- FSAOC6 - Outdoor Cover (3 Color Choices)
- FSAGP1 - Griddle Plate
- FSACT1 - Charcoal Tray
- FSART1 - Rotisserie Kit



Sleek Front Panel Design



Premium Burners



Heavy Duty 8mm Grates



Easy Mount Side Brackets



Traditional Grilling

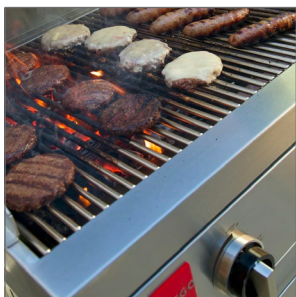

Charcoal Grilling



Griddle Plate



Limited Lifetime Warranty



## TECHNICAL SPECS

|  |   |
|--|---|
| <b>Dimensions:</b>                     | 36" W   24" D   23" H (Lid Closed)<br>36" W   29" D   36" H (Lid Open)  |
| <b>Package Dimensions:</b>             | 34" W   30" D   32" H   |
| <b>Package Weight:</b>                 | 136 Pounds  |
| <b>Gas Requirements:</b>               | 60,000 BTU/hr<br>Natural Gas and Propane Options  |
| <b>Grill Type:</b>                     | Built-In  |
| <b>Clearance To Combustibles:</b>      | Sides: 24"<br>Rear: 24"   |
| <b>Cutout Dimensions</b>               | Width: 36 3/8" (A)<br>Depth : 23 7/8" (B)<br>Height: 11 1/8" (C)  |
| <b>Island Dimensions (Recommended)</b> | Depth: 30" (D)<br>Height: 36" (E)   |
| <b>Mounting Brackets</b>               | Each built-in grill comes with a set of mounting brackets that allows the unit to suspend on top of the countertop opening for a flush mount look and feel. |

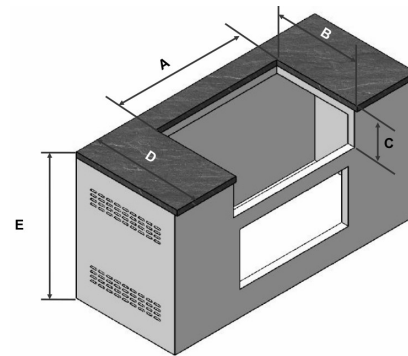
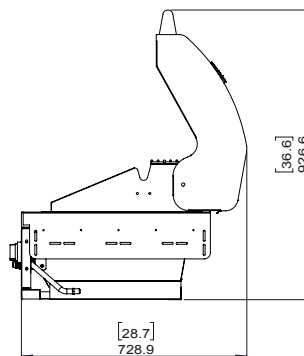
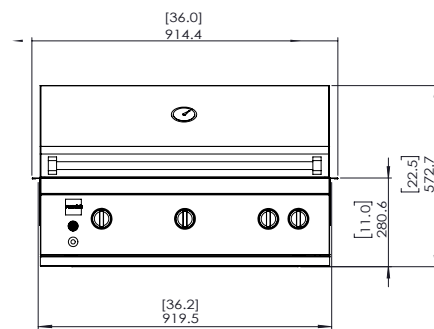
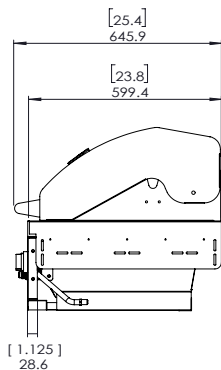

## KEY FEATURES

### Performance

- Two U Shaped 304 SS Burners
- Combined 40,000 BTU/hr
- 645 sq. in. of total grilling surface
  - 510 sq. in. main grilling area
  - 135 sq. in. warming rack
- Overall temperatures range from 250F to 650F
- Heats up to 500F in just 5 minutes

### Features & Benefits

- All 304 Stainless Steel Construction
- Fully Assembled Packaging
- Completely Welded Firebox
- Push Button Electronic Ignition
- Easy-To-Clean Residue Tray
- Heavy Duty 8mm Solid 304SS Cooking Grates
- 3-In-1 Cooking - Grilling | Griddle | Charcoal
- NG and LP Options Available
- Limited Lifetime Warranty

### Optional Accessories

- FSAOC5 - Outdoor Cover (3 Color Choices)
- FSAGP1 - Griddle Plate
- FSACT1 - Charcoal Tray
- FSART1 - Rotisserie Kit



Sleek Front Panel Design



Premium Burners

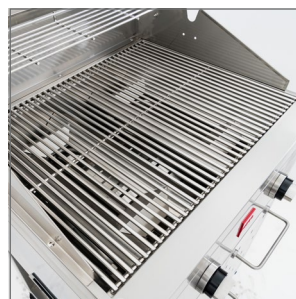

Heavy Duty 8mm Grates



Easy Mount Side Brackets



Traditional Grilling



Charcoal Grilling



Griddle Plate



Limited Lifetime Warranty





## TECHNICAL SPECS

|  |   |
|--|---|
| <b>Dimensions:</b>                     | 27" W   24" D   23" H (Lid Closed)<br>27" W   29" D   36" H (Lid Open)  |
| <b>Package Dimensions:</b>             | 34" W   30" D   32" H   |
| <b>Package Weight:</b>                 | 111 Pounds  |
| <b>Gas Requirements:</b>               | 40,000 BTU/hr<br>Natural Gas and Propane Options  |
| <b>Grill Type:</b>                     | Built-In  |
| <b>Clearance To Combustibles:</b>      | Sides: 24"<br>Rear: 24"   |
| <b>Cutout Dimensions</b>               | Width: 27 3/8" (A)<br>Depth : 23 7/8" (B)<br>Height: 11 1/8" (C)  |
| <b>Island Dimensions (Recommended)</b> | Depth: 30" (D)<br>Height: 36" (E)   |
| <b>Mounting Brackets</b>               | Each built-in grill comes with a set of mounting brackets that allows the unit to suspend on top of the countertop opening for a flush mount look and feel. |

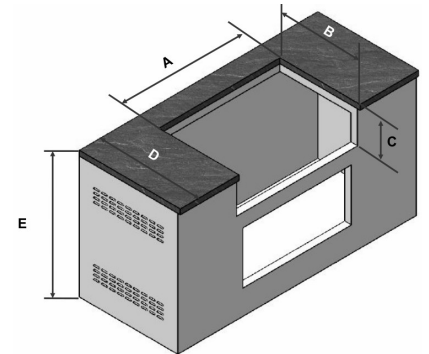
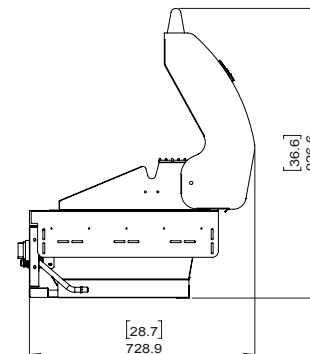
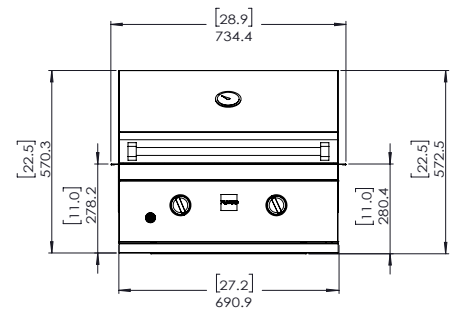
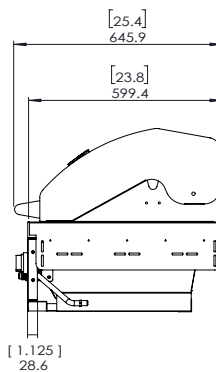

## KEY FEATURES

### Performance

- Two U Shaped 304 SS Burners
- Combined 40,000 BTU/hr
- 400 sq. in. griddle surface
- Overall temperatures range from 250F to 650F
- Heats up to 400F in just 5 minutes

### Features & Benefits

- All 304 Stainless Steel Construction
- Fully Assembled Packaging
- Completely Welded Firebox
- Push Button Electronic Ignition
- Easy-To-Clean Hidden Residue Tray
- Heavy Duty 8mm Solid 304SS Cooking Griddle
- Easy To Remove Griddle Top Cover
- NG and LP Options Available
- Limited Lifetime Warranty

### Optional Accessories

- FSAOC3 - Outdoor Cover (3 Color Choices)

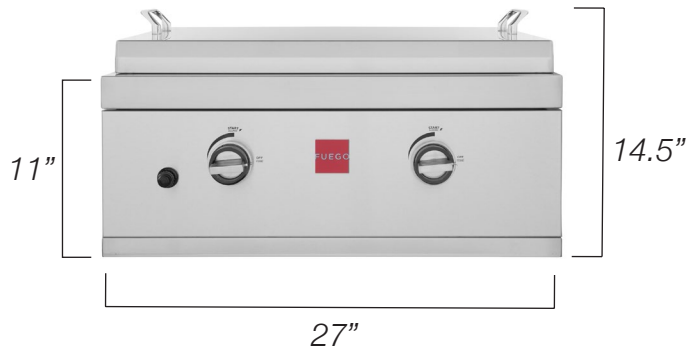

Sleek Front Panel Design



Heavy Duty 8mm Griddle



Premium Burners



Griddle Top Cover

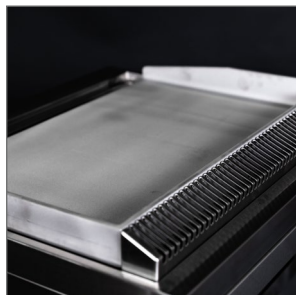

Rear Top Vents



Meat, Veggies & More



Limited Lifetime Warranty



Easy Mount Side Brackets



## TECHNICAL SPECS

|  |   |
|--|---|
| <b>Dimensions:</b>                     | 27" W   24" D   23" H (Lid Closed)<br>27" W   29" D   36" H (Lid Open)  |
| <b>Package Dimensions:</b>             | 34" W   30" D   32" H   |
| <b>Package Weight:</b>                 | 119 Pounds  |
| <b>Gas Requirements:</b>               | 40,000 BTU/hr<br>Natural Gas and Propane Options  |
| <b>Grill Type:</b>                     | Built-In  |
| <b>Clearance To Combustibles:</b>      | Sides: 24"<br>Rear: 24"   |
| <b>Cutout Dimensions</b>               | Width: 27 3/8" (A)<br>Depth: 23 7/8" (B)<br>Height: 11 1/8" (C)   |
| <b>Island Dimensions (Recommended)</b> | Depth: 30" (D)<br>Height: 36" (E)   |
| <b>Mounting Brackets</b>               | Each built-in grill comes with a set of mounting brackets that allows the unit to suspend on top of the countertop opening for a flush mount look and feel. |

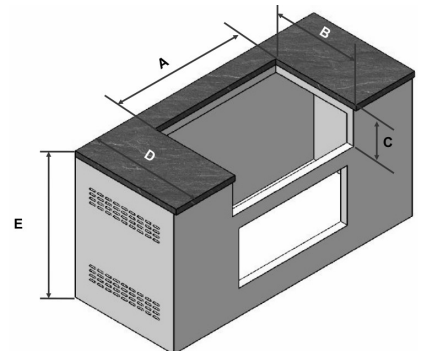
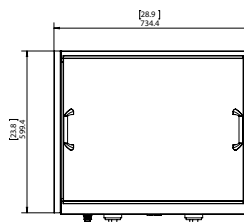
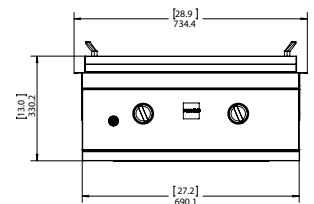
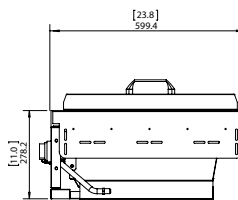

## KEY FEATURES

### Performance

- Dual zone burner system for direct / indirect grilling
- Combined 23,000 BTU/hr
  - Zone 1: 15,500 BTU
  - Zone 2: 7,5000 BTU
- Overall temperatures range from 300F to 650F
- Heats up to 500F in just 5 minutes
- 346 sq. in. of total grilling surface

### Convenience

- Compact 21" x 21" footprint
- Hinged Lid at 45 degree angle
- Hinged propane tank storage door
- Push button electronic ignition
- Easy-to-clean residue removal system
- Built-in lid thermometer
- Easy assembly within 30 minutes

### Optional Accessories

- FEAOC6 - Black Outdoor Cover
- FEACS1 - Clip-on Side Shelf
- FEAPZ1 - Pizza Stone Kit
- FEAGP1 - Griddle Plate
- FEANG2 - NG Conversion Kit





## TECHNICAL SPECS

|                                   |  |
|-----------------------------------|--|
| <b>Dimensions:</b>                | 21" W   21" D   43" H (Lid Closed)<br>24" W   24" D   56" H (Lid Open) |
| <b>Package Dimensions:</b>        | 31" W   22" D   20" H  |
| <b>Package Weight:</b>            | 72 Pounds  |
| <b>Gas Requirements:</b>          | 23,000 BTU/hr<br>Propane Standard<br>Convertible to Natrual Gas        |
| <b>Grill Type:</b>                | Freestanding   |
| <b>Clearance To Combustibles:</b> | Sides: 24"<br>Rear: 24"  |

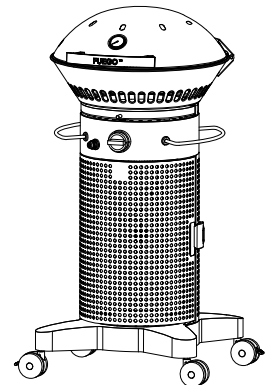
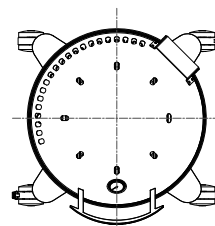
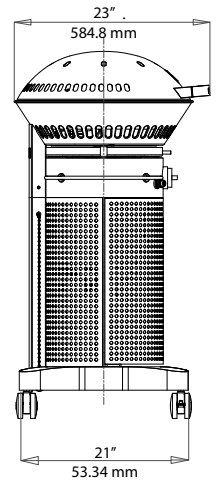
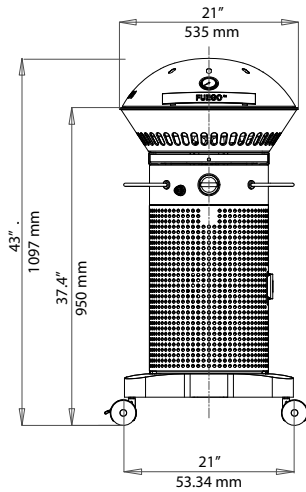

## KEY FEATURES

### Performance

- Dual zone burner system for direct / indirect grilling
- Combined 26,500 BTU/hr
- 525 sq. in. of total grilling surface
  - 415 sq. in. primary grilling area
  - 110 sq. in. warming rack
- Overall temperatures range from 300F to 650F
- Heats up to 500F in just 5 minutes

### Convenience

- Compact 24" x 24" (lid closed) footprint
- Hinged Lid at 45 degree angle
- Hinged propane tank storage door with door clasp
- Push button electronic ignition
- Easy-to-clean drop-through residue removal system
- Built-in lid thermometer
- Easy assembly within 30 minutes

### Optional Accessories

- FPAOC1 - Black Outdoor Cover
- FEACS1 - Clip-on Side Shelf
- FEAPZ1 - Pizza Stone Kit
- FPAGP1 - Griddle Plate
- FPANG1 - NG Conversion Kit





## TECHNICAL SPECS

|                                   |  |
|-----------------------------------|--|
| <b>Dimensions:</b>                | 24" W   24" D   47" H (Lid Closed)<br>28" W   28" D   56" H (Lid Open) |
| <b>Package Dimensions:</b>        | 33" W   26" D   21" H  |
| <b>Package Weight:</b>            | 92 Pounds  |
| <b>Gas Requirements:</b>          | 26,500 BTU/hr<br>Propane Standard<br>Convertible to Natural Gas        |
| <b>Grill Type:</b>                | Freestanding   |
| <b>Clearance To Combustibles:</b> | Sides: 24"<br>Rear: 24"  |

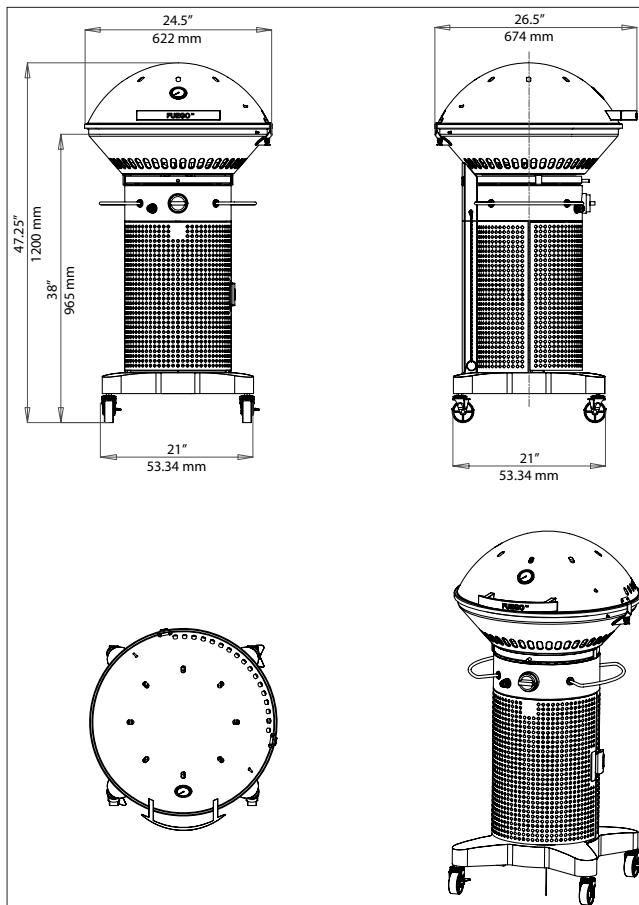



### Drawer Cabinets

- Floating Island Cabinets
  - FCAB-01L (Left Side)
  - FCAB-01R (Right Side)
  - FCAB-01M (Middle)
    - 20" W x 24" D x 36" H
    - Black Stone Countertop
    - Includes Trash Can
- Deep Wall Island Cabinets
  - FCAB-03L (Left Side)
  - FCAB-03M (Middle)
    - 20" W x 30" D x 36" H
    - Black Stone Countertop
    - Includes Trash Can
    - Non Combustible Walls



### Door Cabinets

- Floating Island Cabinets
  - FCAB-02L (Left Side)
  - FCAB-02R (Right Side)
    - 20" W x 24" D x 36" H
    - Black Stone Countertop
- Deep Wall Island Cabinets
  - FCAB04R (Right Side)
    - 20" W x 30" D x 36" H
    - Non Combustible Walls



### Corner Cabinet

- Floating Island Cabinets
  - FCAB-05
    - 38" W x 38" D x 36" H
    - Black Stone Countertop
    - Includes Trash Can
    - Optional Cooler



### Pizza Cabinet

- Floating Island Cabinets
  - FCAB-06
    - 36" W x 24" D x 36" H
    - Black Stone Countertop
    - Fits Fuego Pizza Oven
    - Recessed Side Shelves
    - Optional Foot Pegs



## FLOATING ISLAND OPTIONS

NOTE: All Configurations Not Shown. Please contact Fuego for customized island configurations.

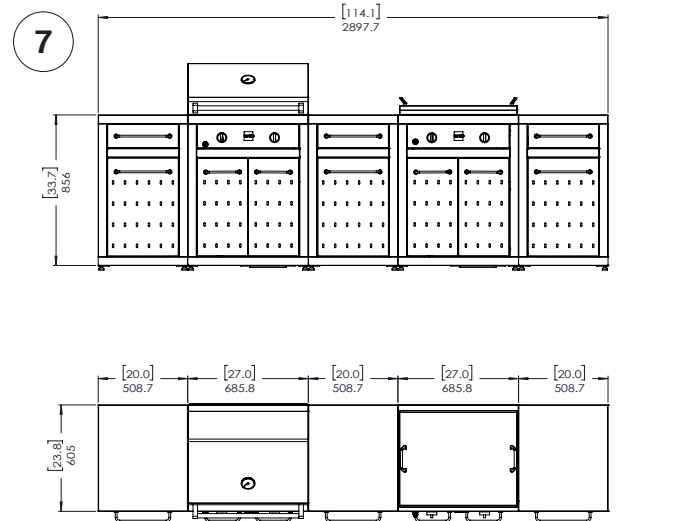
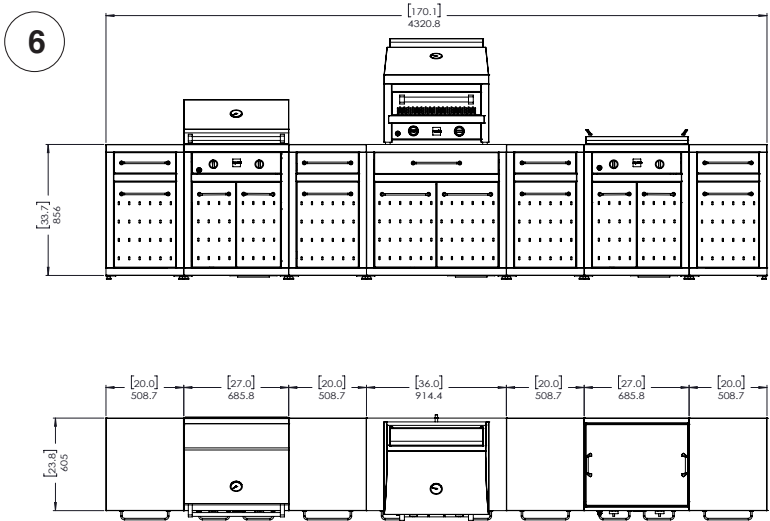
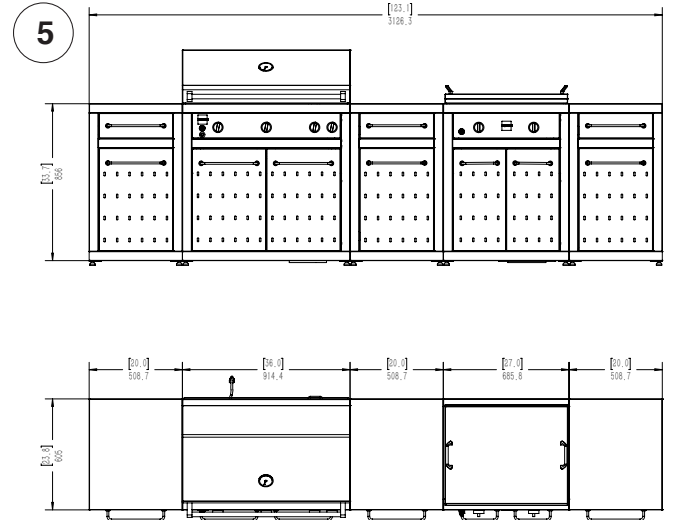
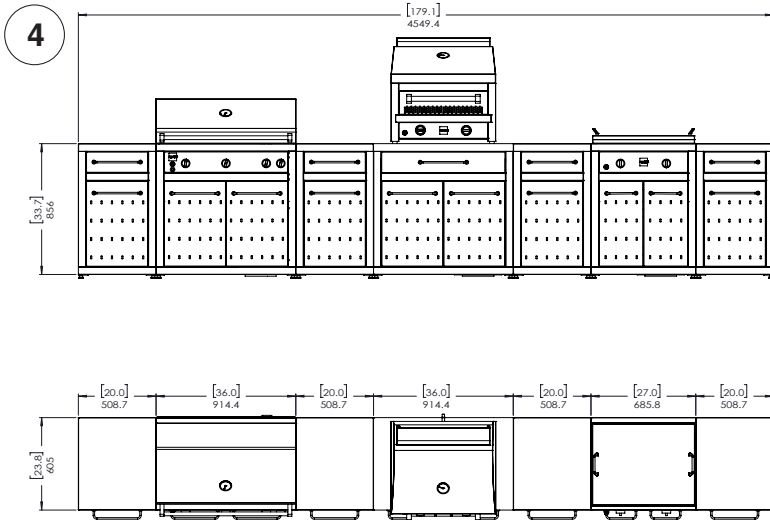
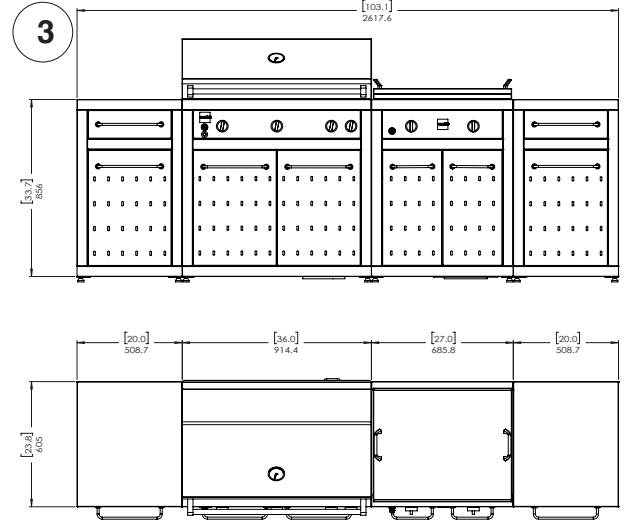
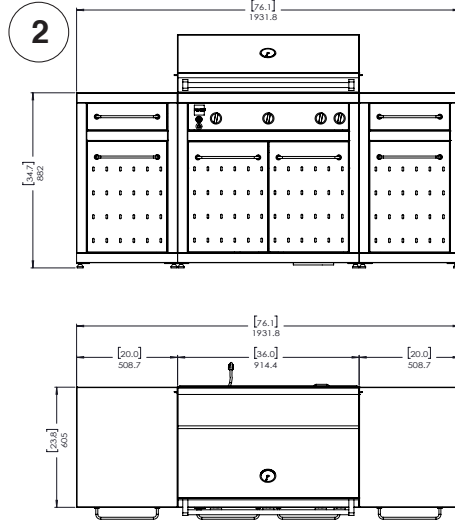
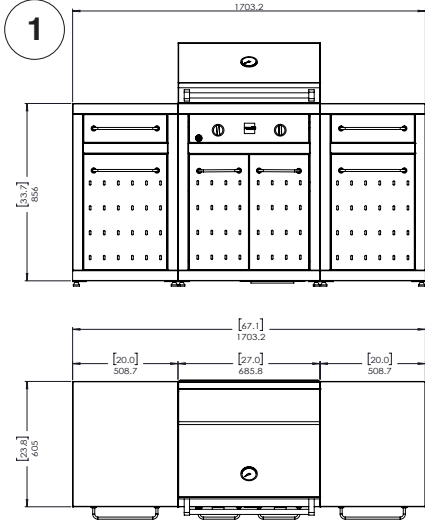

## CORNER ISLAND OPTIONS

NOTE: All Configurations Not Shown. Please contact Fuego for customized island configurations.



## NON-COMBUSTIBLE WALL

NOTE: All Configurations Not Shown. Please contact Fuego for customized island configurations.

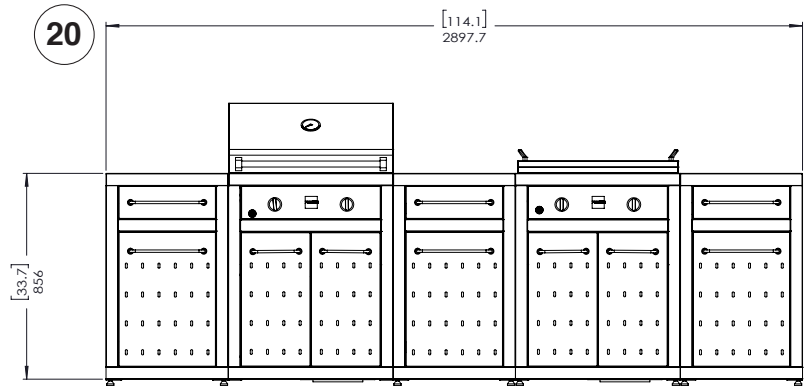
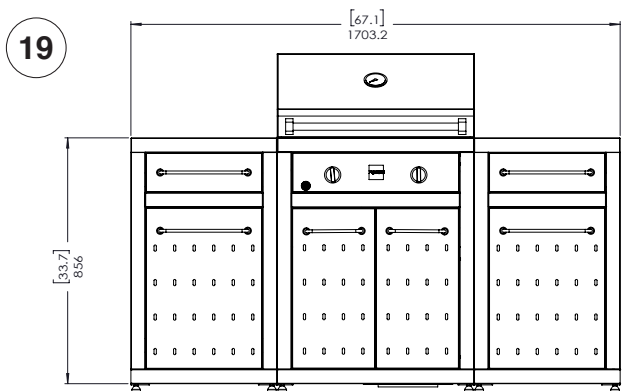
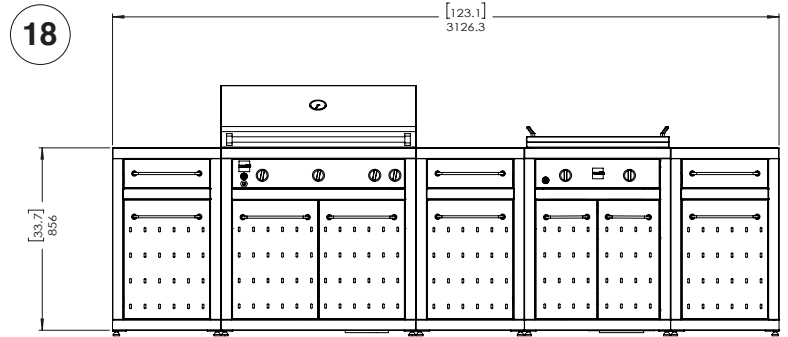
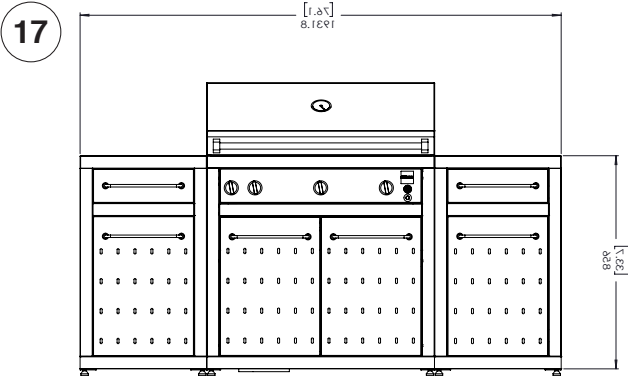

## OPTIONAL ACCESSORIES

**FSAGP1 - Griddle Plate**

- 304SS
- 250 Sq In Cooking Area
- 10 Minute Pre-Heat Time

**FSACT1 - Charcoal Tray**

- 304SS
- Uses Burner Below To Ignite Charcoal
- 15 Minute Pre-Heat Time

**FSART1 - Rotisserie Kit**

- 304SS
- HEX Fork Nuts To Prevent Slipping
- Quiet Motor

**Natural Gas Conversion Kits**

- All Models Convertable To LP or NG
- Simple Manifold w/ Valve Swap Out Conversion
- FSANG1 (F27S)
- FSANG2 (F36S)
- FSANG3 (F36S-PRO)

**Outdoor Covers**

- 500D Light Gray - 3 Year Warranty
- 300D Charcoal - 2 Year Warranty
- PE/PVC Black - 1 Year Warranty



## OPTIONAL ACCESSORIES

**Griddle Plate**

- FEAGP1 - F21C-H Element Griddle
  - 346 Sq In Cooking Area
  - Porcelain Enamel Cast Iron
- FPAGP1 - F24C Professional Griddle
  - 415 Sq In Cooking Area
  - Porcelain Enamel Cast Iron

**FEAPZ1 - Pizza Stone Kit**

- 16" Pizza Stone
- Foldable Pizza Peel
- Pizza Cutter
- Compatible with both Pro and Element Grills

**FEACS1 - Clip On Side Shelf**

- 110 Sq In Side Shelf
- Slots into side handle pocket for easy storage
- Easy to clean surface
- Compatible with both Pro and Element Grills

**Natural Gas Conversion Kits**

- FEANG1 - F21C-H Element NG Kit
- FPANG1 - F24C Professional NG Kit

**Outdoor Covers**

- PE/PVC Black - 1 Year Warranty



FUEGO

# Grills | Griddles | Pizza Oven

