

Chronometric

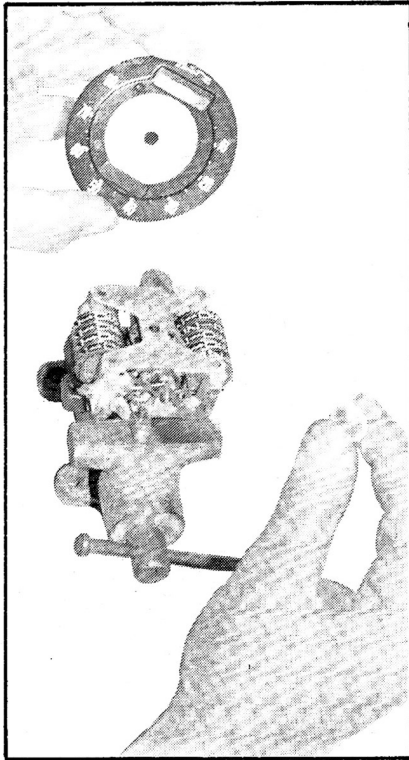

Needle is a press fit on its shaft; use gentle leverage beneath the face, to remove it.

Removal of top plate reveals the complete mechanism. Support in a vice to make dismantling easier.

Two screws attach the Chronometric movement to the main casting. Oil-retaining pads let into the base keep the spindles well lubricated for thousands of miles.

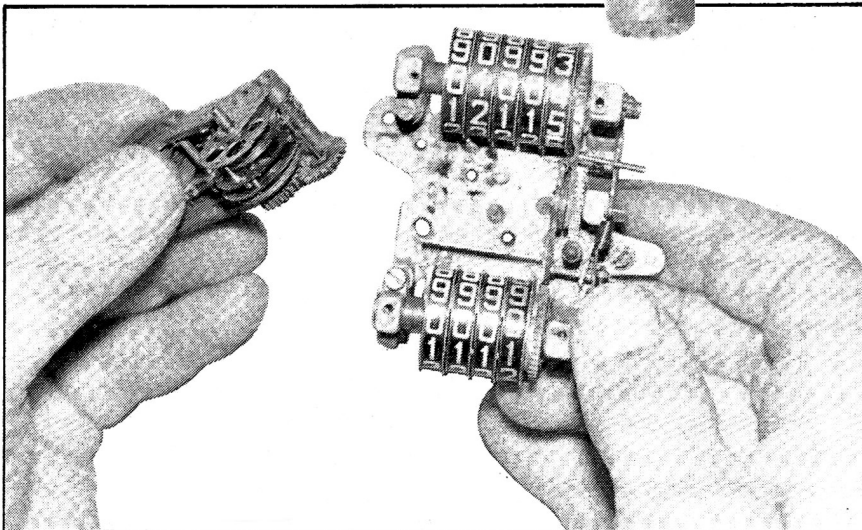

the brake on things. Warmth works wonders — a rag soaked in hot water will usually free the fine threads — and with a cloth wrapped around the top, it can often be undone by hand. Like you, I've come across bezels which have been notched to provide a purchase point, but it's far better to apply force evenly. If hand pressure doesn't do the trick, try an oil-filter strap wrench — the nylon webbing type — applied carefully to the ring. Gentle heat and perseverance is the key. Take off the sealing rubber, glass and supporting ring. It makes putting it back together easier if you use a separate container for each assembly — plastic margarine tubs are ideal.

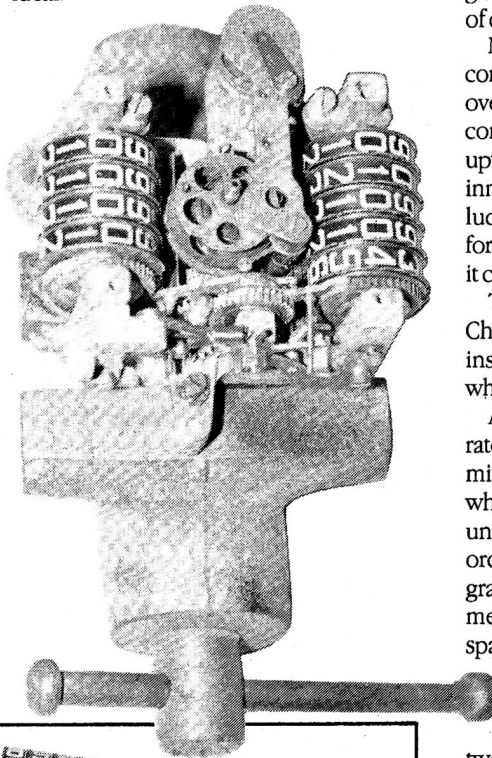

Turn the case over, and remove the screws and starlock washers which hold the gubbins inside, supporting it by the cable attachment to stop it falling flat on its face. (The D type screws down from inside.) Take out the mechanism and undo the dial screws. Operators blessed with only two hands may like to support the assembly in a small vice.

Now, using two screwdrivers *under* the face to prevent damage to the surface, carefully lever off the press fitted needle. If you choose the right size, they can be operated with a cam action, twisting the shafts until the needle pops off. Remove the top plate, where fitted, and before you go any further, inspect the works for signs of distress.

Much of the mechanism is brass, so corrosion is not usually a problem, though over-lubrication can be. Metal dust is more common, and the most likely cause is upward thrust on the drive shaft, caused by inner cables which are over long. If you're lucky it won't be too late, but do look out for a half-dead instrument at autojumbles; it can make a useful parts store.

Two screws in the base remove the Chronometric movement — similar for all instruments — which can be laid aside whilst the odometer section is serviced.

An eccentric wheel is at the centre of the ratchet mechanism which operates the mileage recorder, and the trip meter where fitted. Undo the outer locknut, and unscrew the 7BA bolt from the inside. The order, which can be seen in the photograph, is bolt; brass shim; pawl to trip meter, with spring; eccentric wheel and spacing washer; odometer pawl and spring; driving gear and pin; brass shim; supporting pillar on base; outer plate with pin which takes the two pawl springs; and finally the locknut.

Now the way is clear to remove and inspect the drive shaft, with its pinion and worm. Take out the screw, slide the plate from its slot and lift out the shaft, which sits on a brass washer on top of a felt lubricating pad.

Take the greatest care with cleaning, since even mild solvents will remove dial and odometer drum figures with remarkable efficiency. I have never found it necessary to dismantle the drums, preferring to use soapy water and cotton wool — cotton buds, as sold by chemists, are ideal. Mileage can be zeroed by springing the retainers gently back; useful if you are putting together an instrument for a 'rebuilt as new' machine.

Overhauling the Chronometric

Wash the Chronometric movement by swilling it in petrol — white spirit is more acceptable inside the house — using a small brush to dislodge the muck. Over-oiling of cables; or tachometer drives which pump engine oil upwards, are the main culprits here. Brass gears are self-lubricating and don't need lashings of axle grease. Dry carefully and prepare for the really interesting bit.

I have an aversion to instructions which say blithely: RE-ASSEMBLY IS THE REVERSE OF DISMANTLING. Everyone knows that taking things to bits is the easy part, and that all the problems start when bolting it back together. So let's assume

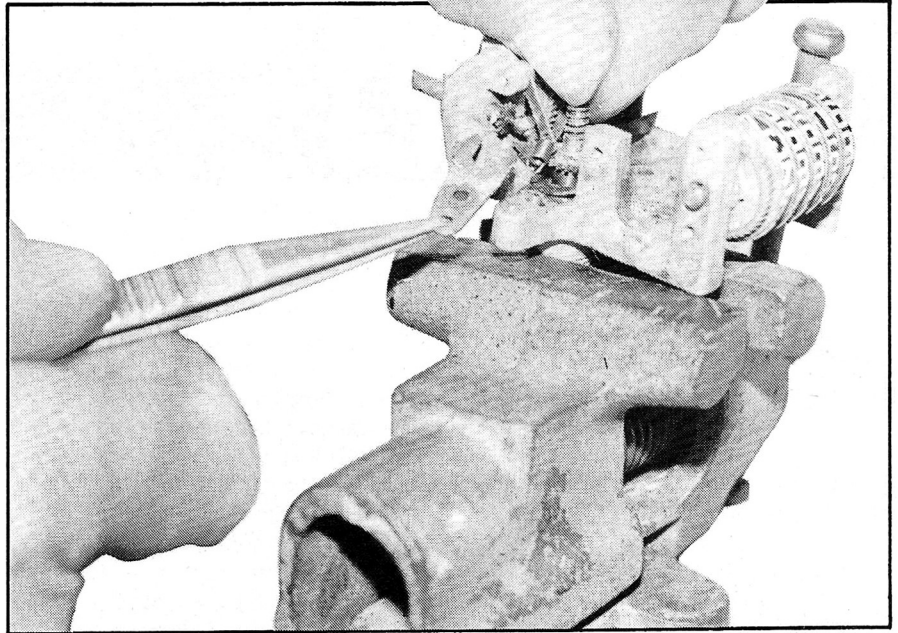

Screw and plate retain the main drive spindle. Note the particles of metal around this one; an outward sign of mechanical malaise.



Worm on drive shaft turns gear A, and eccentric drive to the pawl B, which turns the recording drum ratchet.

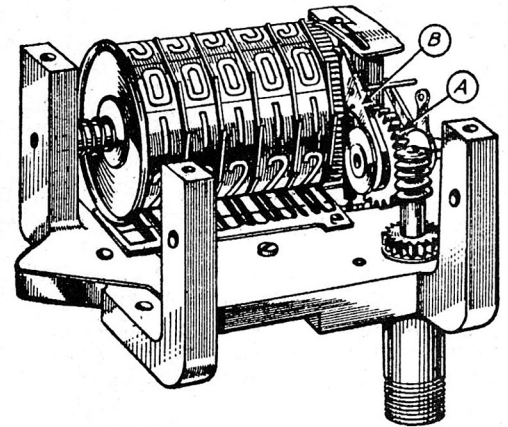

Petrol and a small brush will take the grease from a mucky movement before dismantling, but keep all solvents away from the face and millimeter drums.

How it works

The speedometer cable turns a chain of gears which drive a camshaft, its speed set by the escapement and its balance wheel.

One cam operates a rocker, which pulls a rocking spindle into mesh with the integrator wheel, turning this as far as it will go — dependent upon input speed — in $\frac{3}{4}$ of a second. The integrator wheel drives the recorder wheel, and a pin locates with the stabiliser wheel, which carries the needle.

After $\frac{3}{4}$ of a second, the camshaft disengages the rocking spindle, but the wheel is held by a sprung finger engaging in its teeth. The integrator wheel is released, and a hair spring returns it to zero. Soon afterwards the cam releases a third spring on the recorder wheel, which returns to zero with the needle.

In practice, the rocking spindle will re-engage before the needle returns to zero, unless the drive has stopped. So the recorder wheel will react to any change in the number of revolutions it makes in $\frac{3}{4}$ of a second, transferring this to the needle.

that each piece is scrupulously clean, and try a different approach, describing how to assemble the mechanism, and advising that: DISMANTLING IS THE REVERSE OF RE-ASSEMBLY.

Begin with the camshaft and its brass escape wheel, which is regulated by the escapement anchor and driven through a clutch. Take the shaft, fit the small plastic disc; the diablo spring; the large plastic disc; the pinion with its recess outward. Compressing the spring gently, slip the fibre retaining clip into its groove. Place the camshaft in the centre hole of base plate.

Next the needle assembly, which fits the captive shaft on the base plate. Fit a washer, followed by the fibre gear, boss to

the top, and — meshing with it — the driving pinion and its rocking mainshaft. Then, onto the captive shaft place another washer; the integrator wheel assembly with its three-spring clutch, pinion to the top, and the hairspring fitting in its groove in the post.

Fit the next washer, followed by the recorder wheel, again hooking the spring around the post. Slip on the rocking spindle's top bearing, which is one end of the rocker which pivots on the post, while its forked end locates either side of the top cam. A final washer on the main shaft is followed by the stabiliser wheel, its stub to the top and the small hole accepting the recorder wheel's pin.

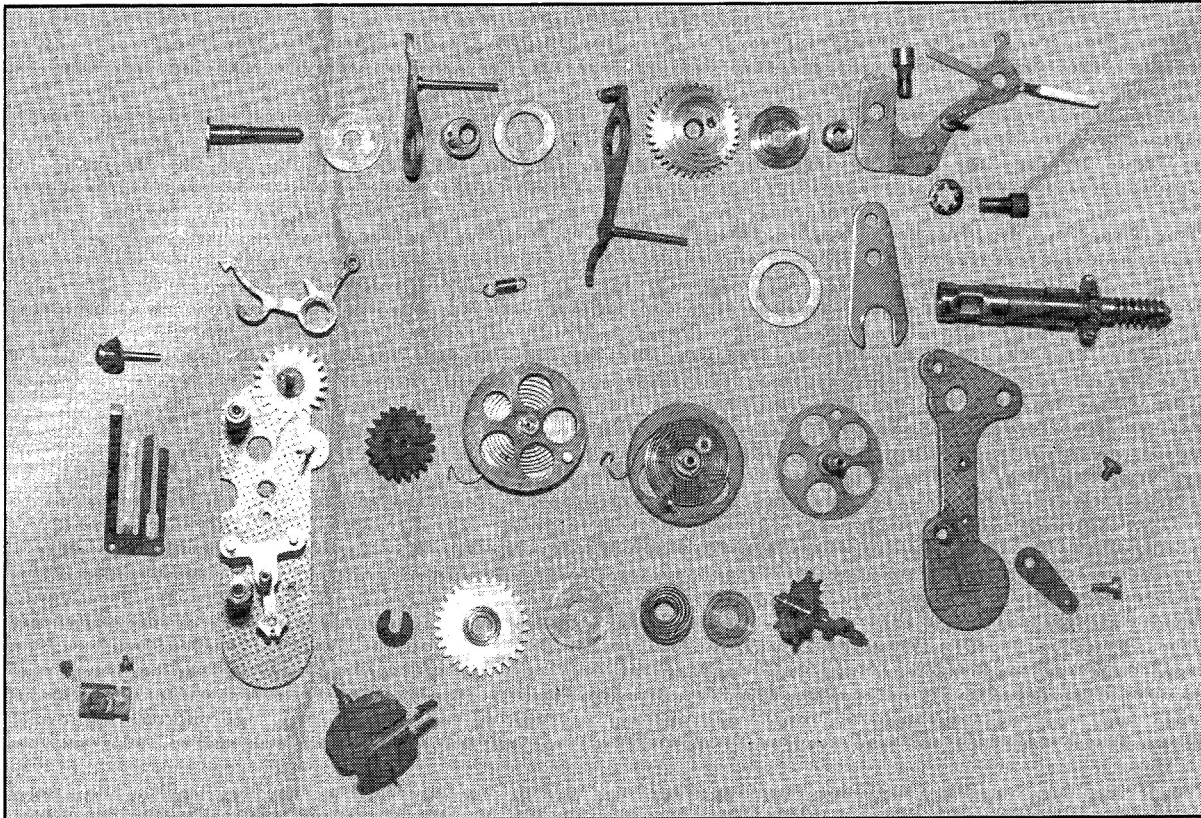

Everything you need to build your own Chronometric movement, and what's more it's laid out in the correct order.

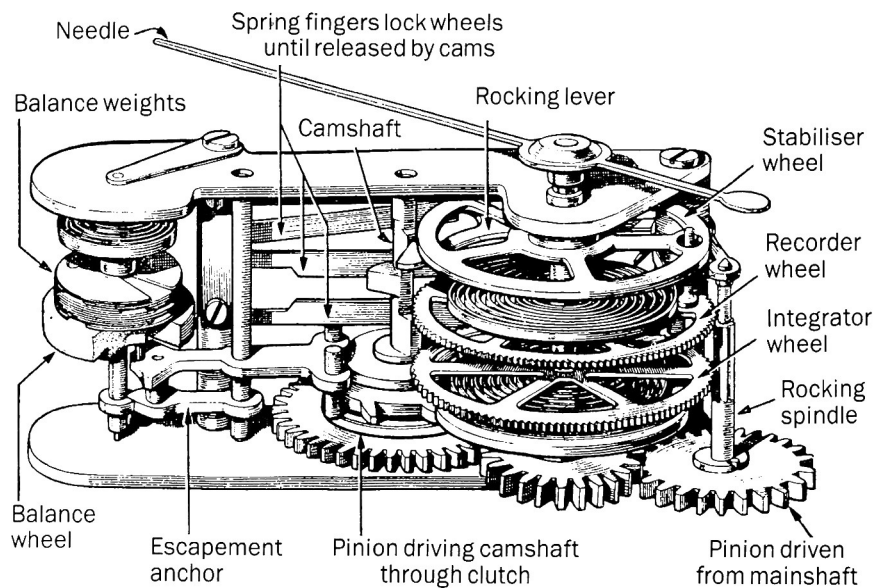

Rocking drive spindle samples the input shaft speed for $\frac{3}{4}$ of a second, with every revolution of the camshaft.

Now fit the escapement anchor, checking that its pins are in good shape. They can be worn by the escape wheel, causing it to stick, but they are a press fit. So it is possible to tap them out and reverse them, using a spot of Loctite, to present an unworn surface to the escape wheel's teeth.

Fit the balance wheel assembly, locating its cam and pin with the escapement arm. The balance weights effect the balance wheel's inertia, and ultimately the speed reading, and I'm sure that Smiths had a formula for setting accuracy. I'm not privy to its secrets, but if you want to experiment, give it a try.

Now fit the spring plate to the inside of

the escapement post — two screws — aligning the springs, the lower two securing the integrator and recorder wheels; the third to the rocker shaft, holding the rocking spindle in mesh except when the cam disengages it. The top finger sits in a notch in the stabiliser wheel, and zeros the needle.

Secure the balance wheel hair spring under its grooved plate, and the recorder and integrator hair springs beneath the oval plate on the opposite pillar. The elongated bolt forms a stop for the integrator and recorder wheels, which should be given about $\frac{1}{4}$ turn clockwise before the pin is fitted, so that they are held back against it by spring pressure.

Finally, replace the top plate, aligning the spindles carefully and fitting the longer of the two screws to the plate above the balance wheel. Use a little light machine oil on the bearings, keeping the camshaft clutch dry.

Before fitting the Chronometric unit, oil the two felt pads beneath it, and reassemble the odometer ratchets and eccentric wheel, using a spot of sewing machine oil as you build up the mechanical sandwich in — sorry — the reverse order to dismantling. Lubricate the main drive spindle felt, refit the washer and spindle, and fit the retaining plate and screw. Finally, test the action of the ratchets by turning a small screwdriver in the cable drive, and screw the refurbished mechanism to the base casting.

The completed instrument can be returned to its case after painting. A coat of white inside helps reflect light for better illumination, and a piece of white paper beneath the dial does the same job. Original equipment was a gasket between case and movement — blotting paper would make a good substitute, and may catch some stray lubricant. When refitting the needle, make sure that the stabiliser wheel is set to zero, and note that most speedometers indicate the 5mph marking when at rest; not zero. Seal the glass carefully to keep the rain out — silicone gasket is ideal — and take care that your cable outer has no tendency to spring away from the threaded stub. Grind the inner back if it's too long.

How fast does your bike go? Now you'll be able to tell them. ■

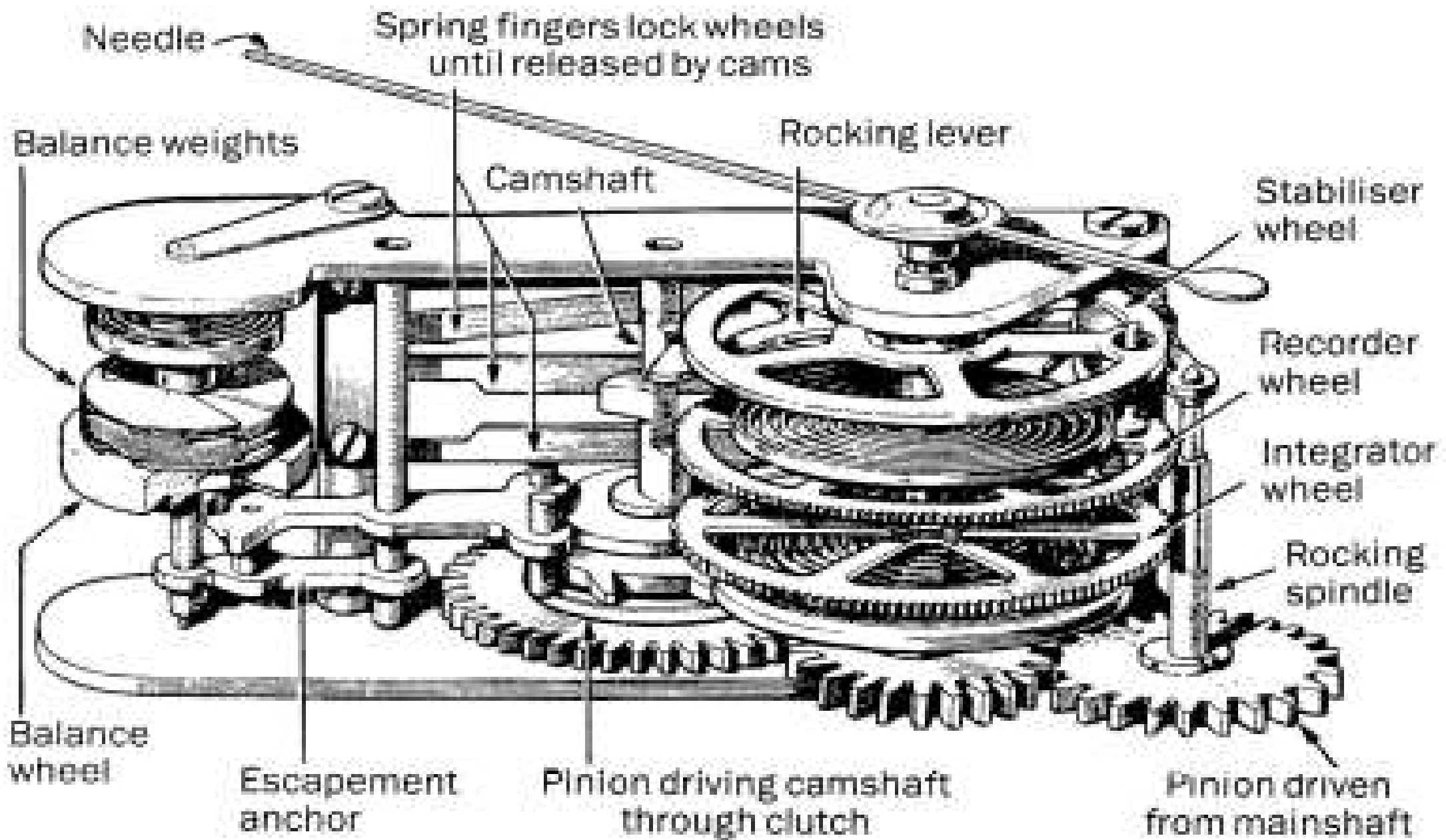

Rocking drive spindle samples the input shaft speed for $\frac{1}{4}$ of a second, with every revolution of the camshaft.

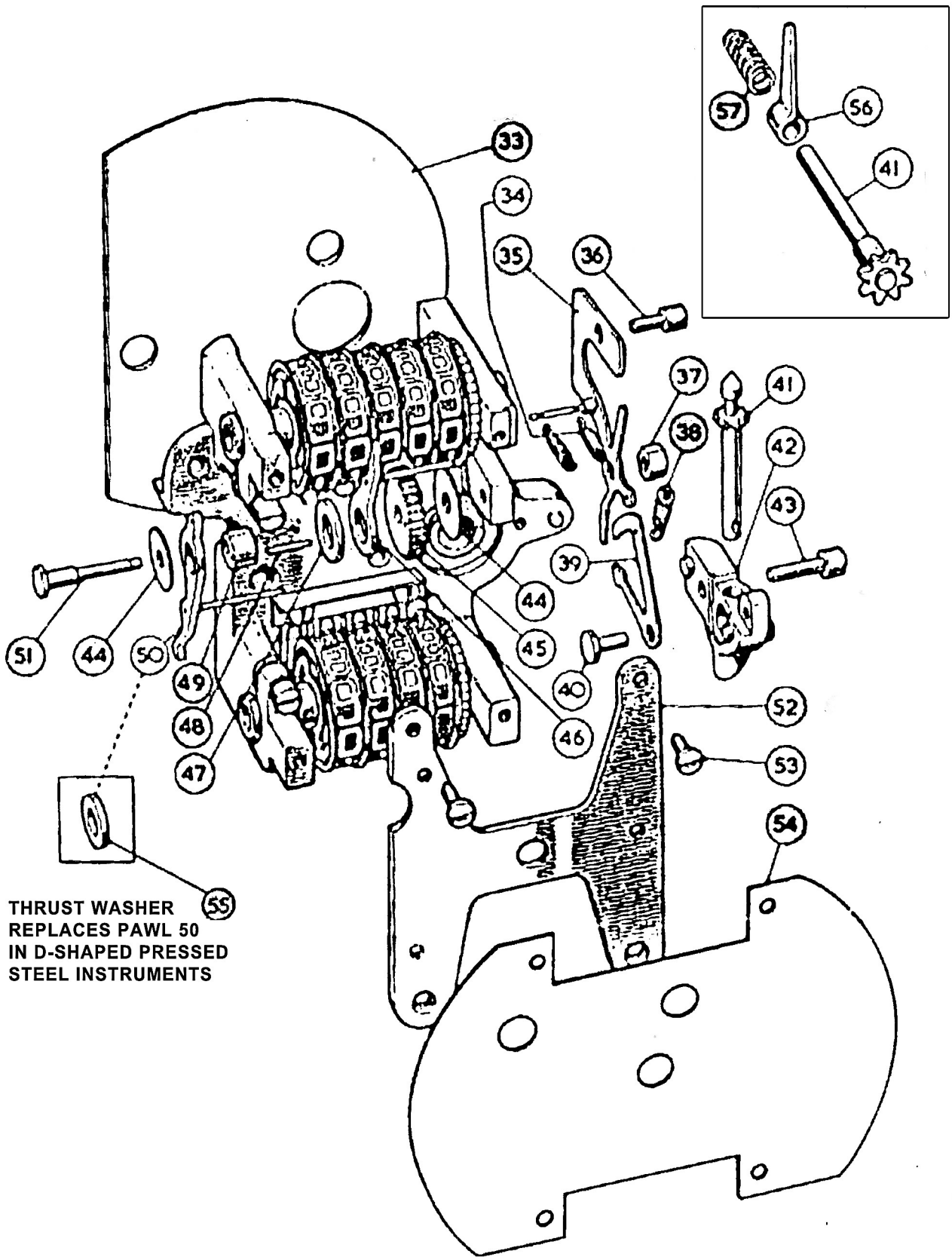

- | | | |
|-------------------------------------|-----------------------------|---|
| 33 Internal Felt Packing | 42 Bridge | 50 Trip Pawl Complete |
| 34 Spring (for Total & Trip Pawl) | 43 Fixing Scre (for Bridge) | 51 Worm Wheel Shaft |
| 35 Arm End Plate | 44 Pawl Friction Washer | 52 Transfer Plate |
| 36 Fixing Screw (for Arm End Plate) | 45 Worm Wheel | 53 Transfer Plate Screw |
| 37 Worm Wheel Shaft Nut | 46 Total Pawl Complete | 54 Dial Paper Washer |
| 38 Spring (for Clutch Lever) | 47 Pawl Distance Washer | 55 Thrust Washer |
| 39 Clutch Lever | 48 Eccentric Pin | 56 Sleeve & Trip Pin (for Trip Reset Spindle) |
| 40 Clutch Lever Pivot | 49 Eccentric | 57 Spring (for Trip Reset Spindle) |
| 41 Trip Reset Spindle | | |

Chronometric Speedometer (Circular Type). General Arrangement of Frame.

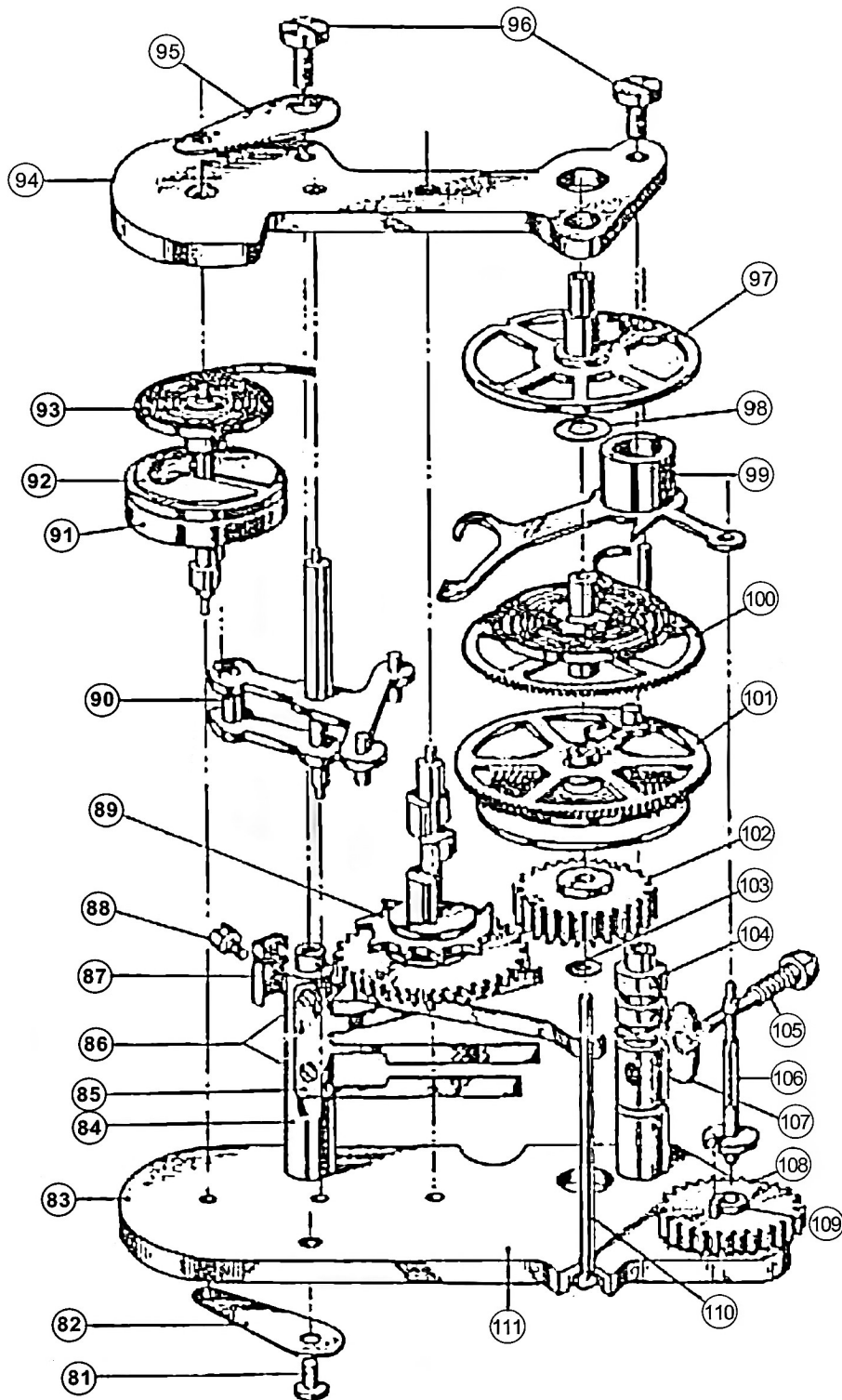

- | | | |
|--|--------------------------------|-----------------------------------|
| 81 Rivet (for Balance Wheel End Plate) | 92 Regulating Washer | 102 Centre Wheel Complete |
| 82 Balance Wheel End Plate | 93 Balance Hairspring Complete | 103 Centre Spindle Washer |
| 83 Bottom Plate | 94 Top Plate | 104 Rocker Pillar |
| 84 Pillar (Four Leaf) | 95 Balance Wheel End Plate | 105 Stop Screw |
| 85 Four Leaf Spring | 96 Fixing Screw (for Pillars) | 106 Commander Pinion |
| 86 Screw (for Leaf Spring) | 97 Stabilisator Wheel Complete | 107 Pillar Plate |
| 87 Hairspring Fixing Plate | 98 End Shake Washer | 108 Movement Drive Wheel Complete |
| 88 Screw (for Hairspring Fixing Plate) | 99 Rocker Complete | 109 Movement Drive Wheel Bush |
| 89 Camshaft Assembly Complete | 100 Corrector Wheel Complete | 110 Centre Spindle |
| 90 Fork & Spindle Assembly | 101 Integrator Wheel Complete | 111 Bottom Plate Assembly |
| 91 Balance Wheel Assembly | | |

* This assembly comprises Illustration Nos. 81, 82, 83, 84, 103, 104, 108, 109 & 110.

Chronometric Speedometer. General Arrangement of Movement for Circular and 'D' Shaped Instruments.

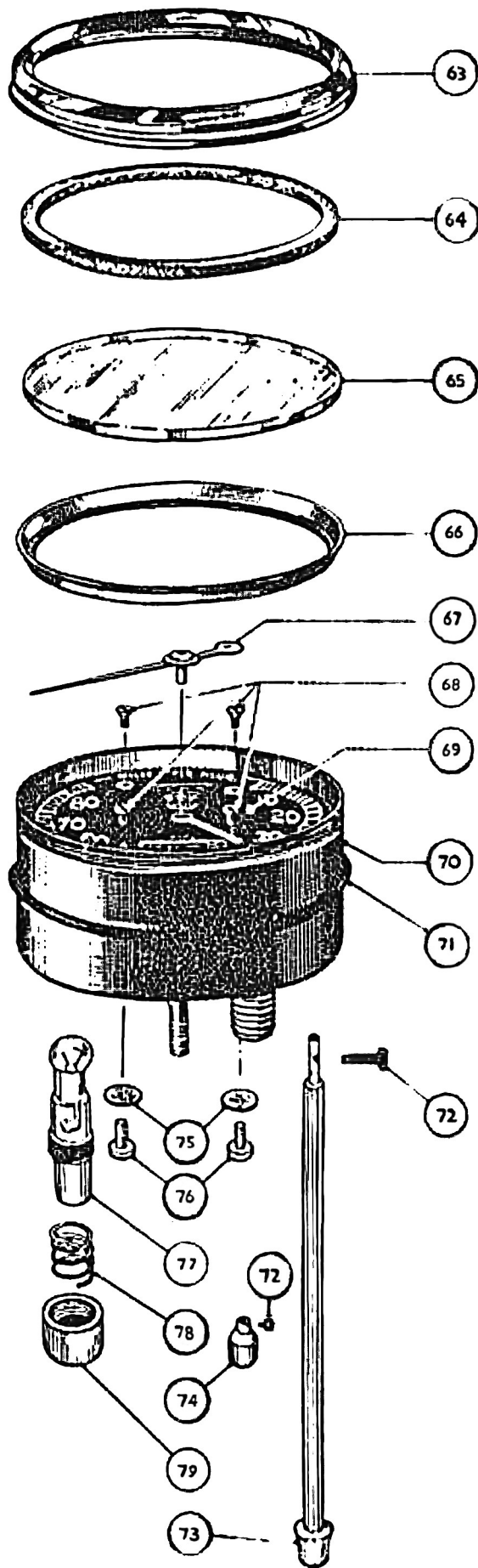

- 63 Bezel
- 64 Rubber Ring (Internal)
- 65 Glass
- 66 Slip Ring
- 67 Pointer
- 68 Dial Screw
- 69 Dial
- 70 Case
- 71 Rubber Ring (External)
- 72 Split Pin or Screw (for Trip Knob)
- 73 Trip Knob Assembly
- 74 Trip Knob
- 75 Casing Washer
- 76 Casing Screw
- 77 Bulb & Bulb Holder
- 78 Retaining Spring (for Bulb Holder)
- 79 Retaining Ring (for Bulb Holder)

Chronometric Speedometer (Circular Type). General Arrangement of External Parts.