



# TRIMO

SOLUCIONES ARQUITECTÓNICAS  
DE PANEL

# TRIMO

Trimo es líder europeo en soluciones arquitectónicas de panel para Fachadas y cubiertas con un alto componente estético



**TRI  
MO**

**TRI  
MO**  
QBISS  
ONE



**TRI  
MO**  
QBISS  
SCREEN

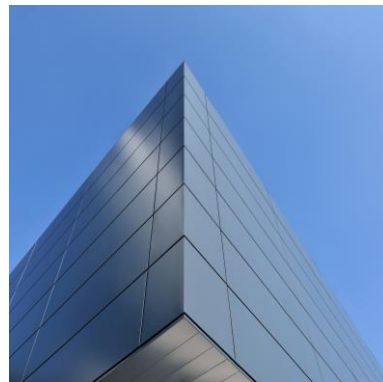

**TRI  
MO**  
TRIMOTERM



**PRODUCTOS**

## ALGUNOS DE NUESTROS CLIENTES

PHILIPS

Nestlé



AKRAPOVIČ



IKEA



McLaren



## CERTIFICADOS

MÁS DE 1.500 CERTIFICADOS EN 23 PAÍSES ALREDEDOR DEL MUNDO.



Cert. No. 650a to LPS 1208  
Cert. No. 650b to LPS 1181  
Cert. No. 650d to LPS 1181



Mitglied des:

**IFBS** Industrieverband  
für Bausysteme  
im Metallleichtbau

# TRIMO

## VENTAJAS

¿Qué hace a nuestros paneles Arquitectónicos únicos?



**Calidad**  
alta calidad



**Resistencia al fuego**  
fuerte resistencia al fuego  
superior a 240 min



**Eficiente energéticamente**  
excelente aislamiento  
térmico y acústico



**Resistencia Mecánica y Estanqueidad al aire y al agua**



**Mayor Clase A+ de acuerdo con BREEAM**



**Certificados**



**BIM**



**Excelente servicio al cliente**



**Soporte técnico**



# TRIMOTERM

PANELES IGNÍFUGOS DE ALTAS PRESTACIONES

### ■ LANA DE ROCA

- Clase A1 incombustible-resistente al fuego
- Alta densidad. 90-140 kg/m<sup>3</sup> dependiendo de las necesidades

### ■ ESPESOR DE CHAPA Y LACADO

- Espesores chapa exterior 0.50 a 0.70 mm
- Espesores chapa interior 0.50 a 0.60 mm
- Galvanizada (Zn, ZnMg, ZnAl)

Tipos de acabado:

- Standard Poliester
- PVDF
- PUR
- PVC

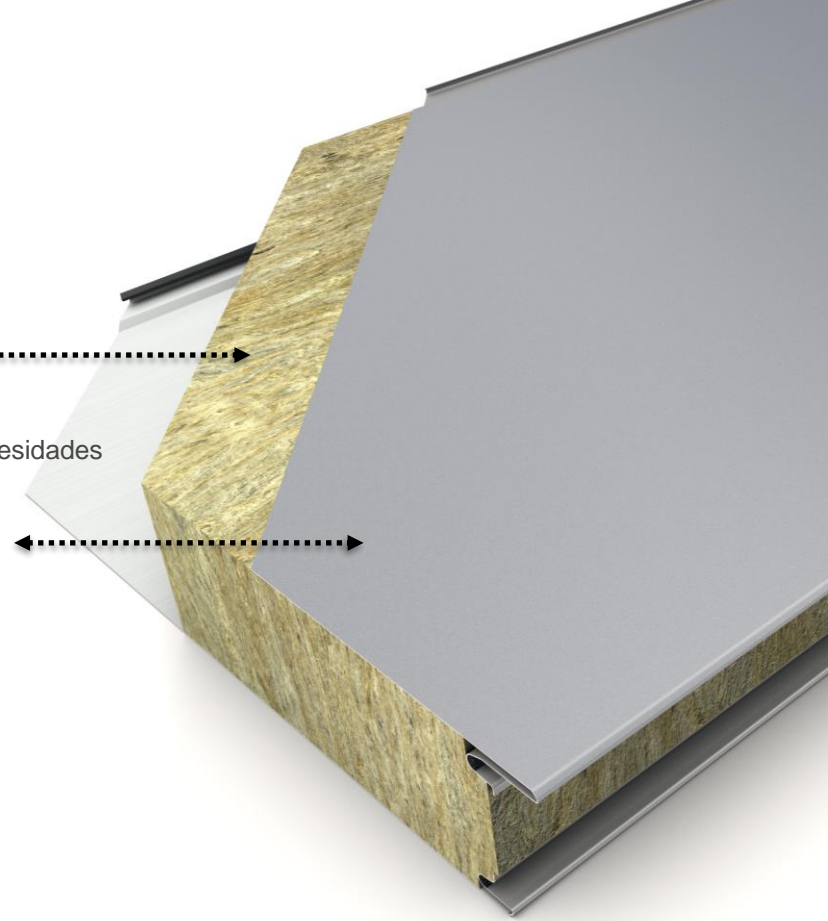

# TRIMOTERM

## TRIMOTERM FTV (FACHADA)

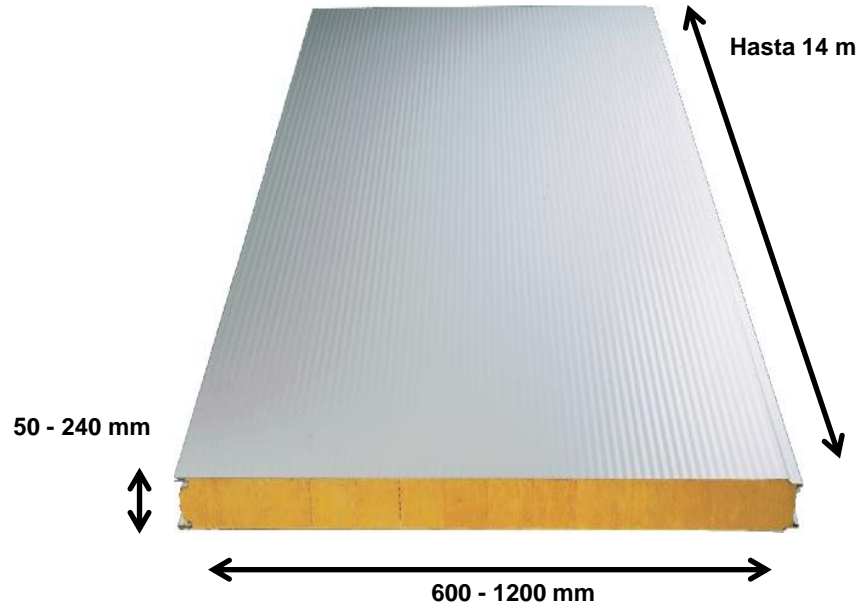



# TRI MO

Detalle de Fijación con  
grapa en zona no  
expuesta

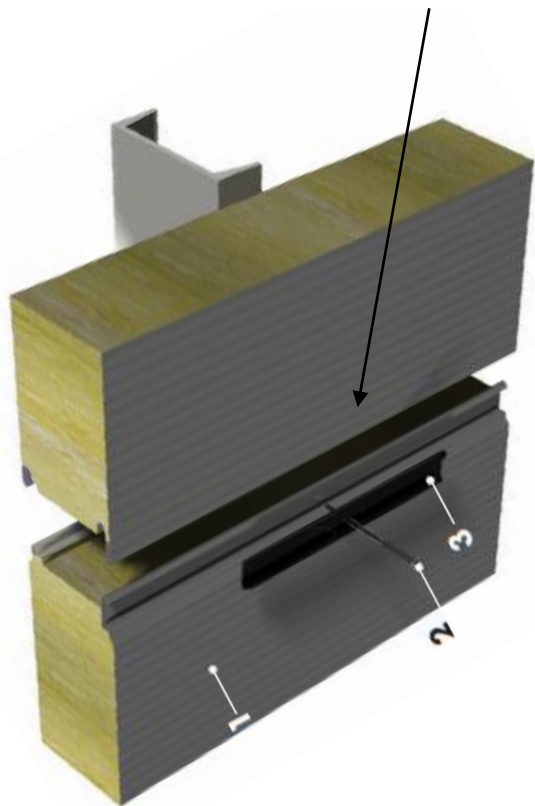

Detalle de fijación con  
grapa en zona no  
expuesta

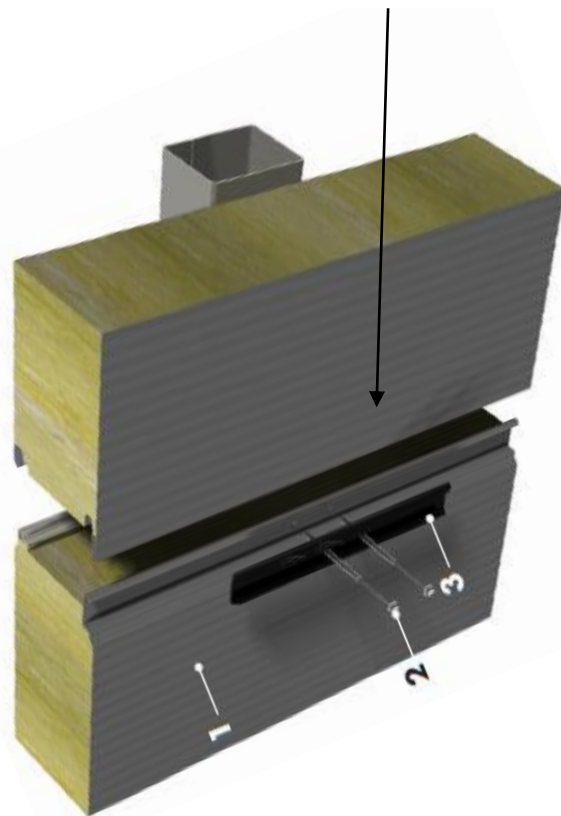



TRI  
MO



TRI  
MO



TRI  
MO



# TRI MO



| Qbiss One B



| Qbiss One F



| Qbiss One FB



| Qbiss One BF

# QBISS ONE

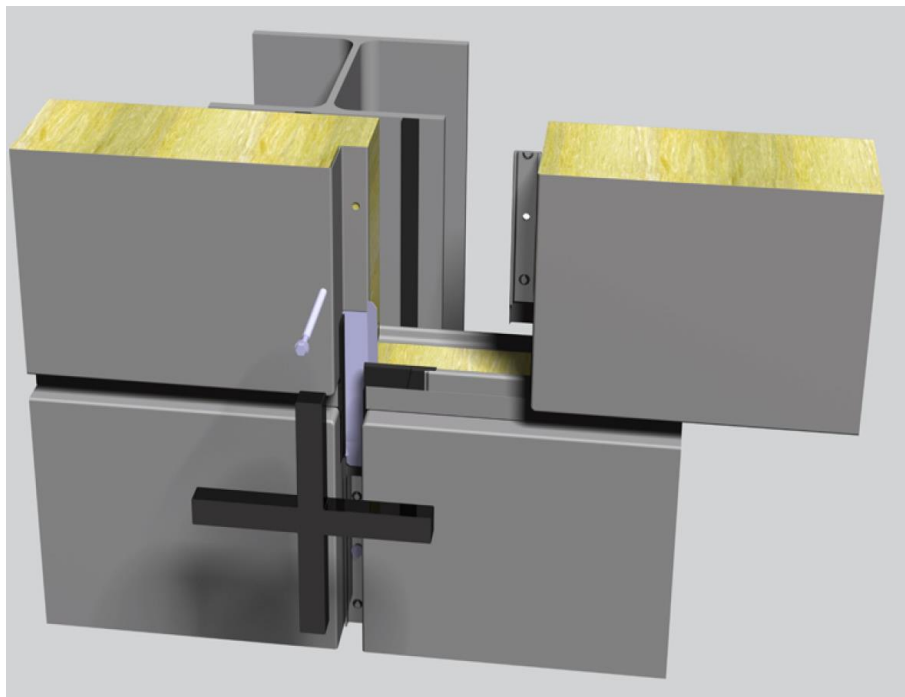

## ART ME



- Posibilidades ilimitadas para personalizar sus creaciones
- Diseños únicos o “pre-seleccionados” (Puzle, Burbujas, Líneas)
- Acabado de fachada de alta calidad
- Máximo efecto visual al mínimo coste
- Tecnología revolucionaria

## ELEMENTOS DECORATIVOS



# TRIMO

## POSIBILIDADES

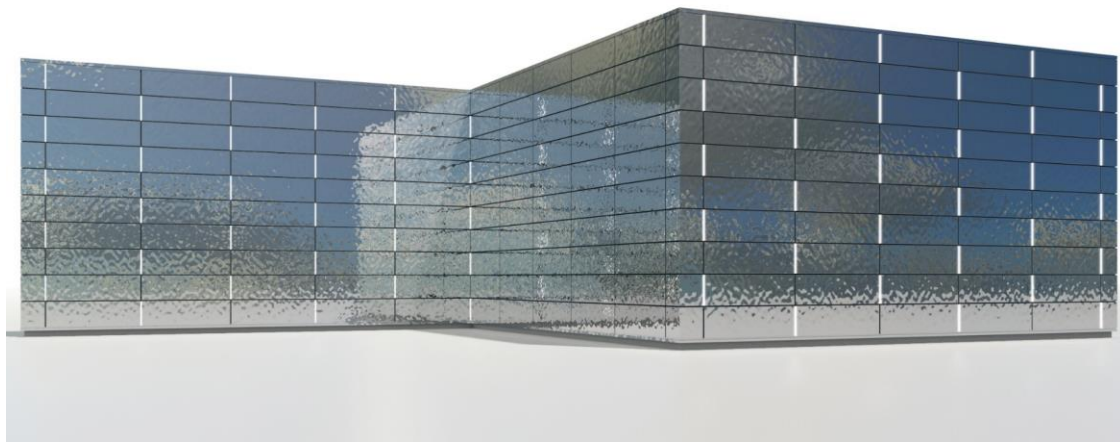
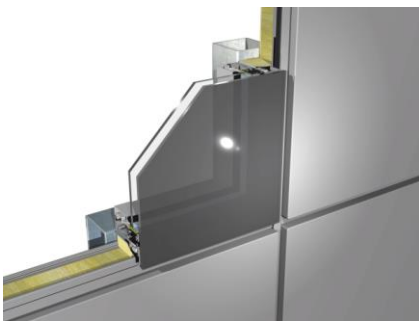



# TRIMO

## POSIBILIDADES

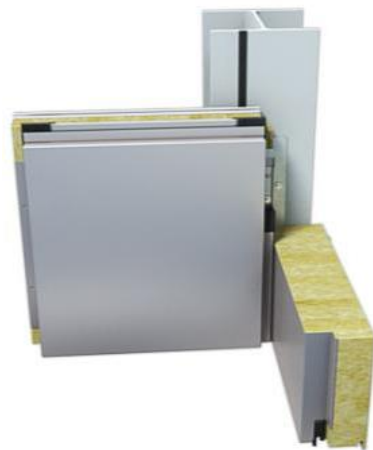
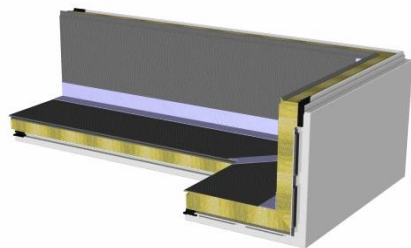
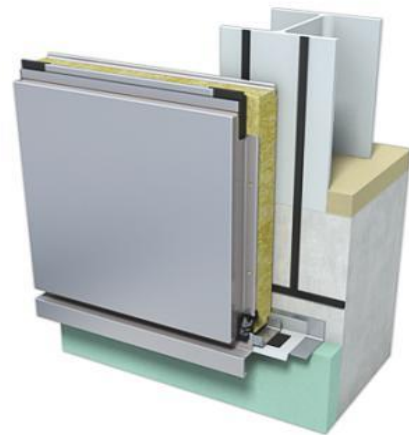
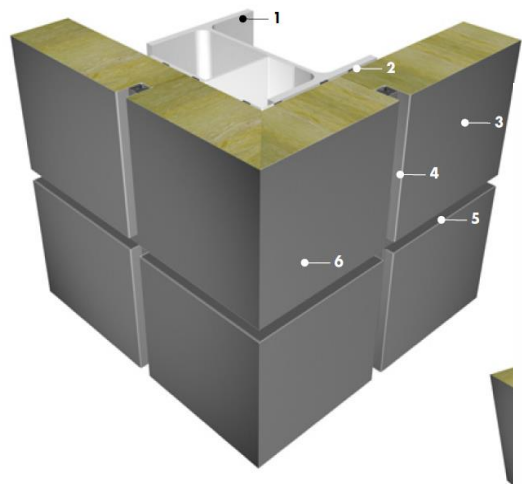

**TRI  
MO**

# QBISS SCREEN SISTEMA DE FACHADA VENTILADA

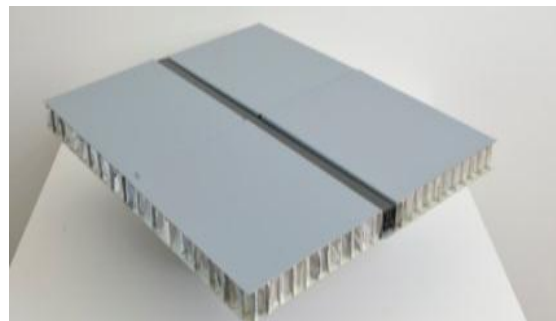
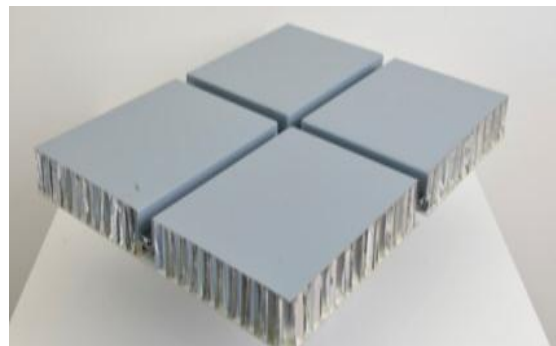
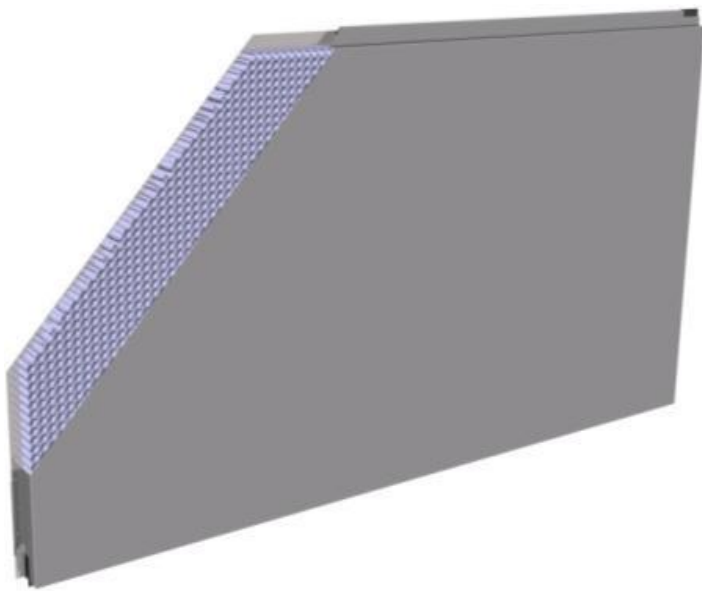

# TRIMO

## QBISS SCREEN SISTEMA DE FACHADA VENTILADA

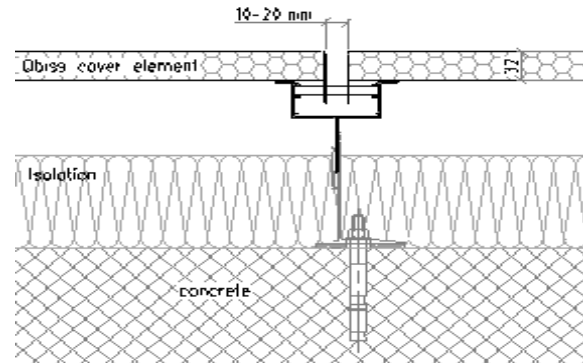
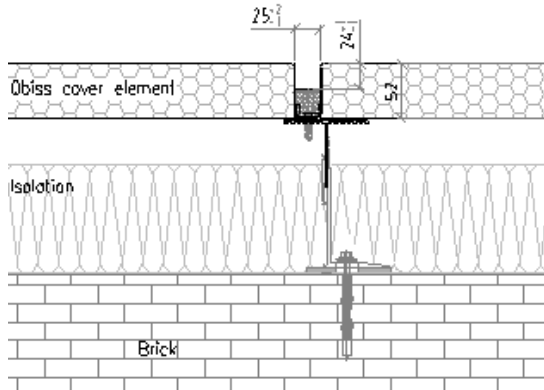

TRI  
MO

# SEDE CENTRAL MANGO



TRI  
MO

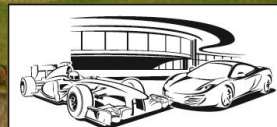

McLAREN TECHNOLOGY CENTRE  
OFFICIAL PARTNER

Qbiss

TRI  
MO



TRI  
MO

