



LED Gas Station Light



FEATURES

- IP65 rated
- Rust & corrosion proof
- 50,000 hours lifetime

APPLICATIONS

- Gas Station
- Factories
- Parking Lots
- Shopping Malls
- Supermarkets
- Auto dealerships

PRODUCT DIMENSIONS

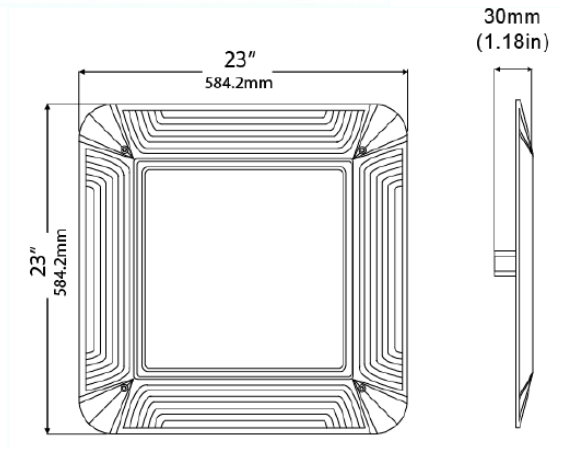

CONSTRUCTION Heavy die-cast aluminum housing with white powder-coated finish.	CONTROLS AND DIMMING Non-dimmable.
OPTICAL SYSTEM SMD LED chips. Frosted lens. 120° beam angle.	INSTALLATION AND MOUNTING Wall mount with quick mount back plate.
ELECTRICAL 120-277V input. -20°C to 50°C (-4°F to 122°F).	WARRANTY 5-year limited warranty. Actual performance may differ as a result of end-user environment and application.

Part Number 120-GCP-150-50-27

WATTAGE SELECTABLE	CCT	LUMENS	EFFICACY	VOLTAGE	CRI	POWER FACTOR	THD	REPLACES
150W	5000K	20,590LM	142lm/w	120-277V	70	.97	9%	520W HID