

World Class Performance
in Abrasive, Scaling and
Corrosive Slurries, Sludge,
Liquids, and Bulk Solids

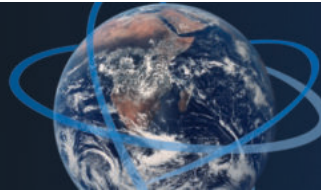

INSAMCOR - LW
Lugged Wafer Knife Gate Valves



DUCTILE IRON - INSAMCOR® LW

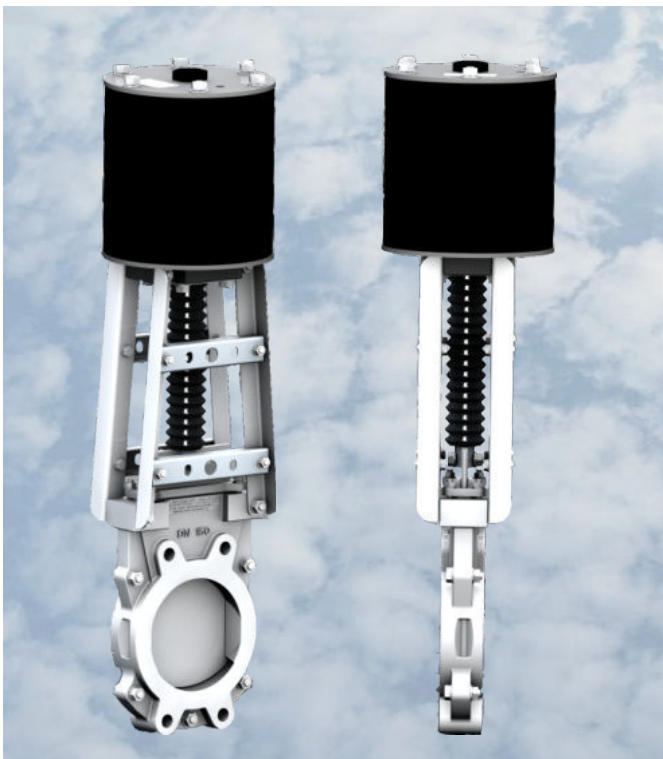

STAINLESS STEEL - INSAMCOR® LW

DFC's purpose is to solve typical and perennial valve problems. We achieve this by providing quality valves that provide the lowest cost of ownership and operation, highest reliability and minimum lifetime maintenance.

DFC's Insamcor range of lugged wafer ductile iron & stainless steel bi-directional knife gate valves feature a unique moulded body seal with no seat pockets or cavities providing trouble free operation in slurry applications.

Design Features and Advantages

- Mechanically retained moulded body seal
- Gate guided through full length of the stroke
- Self-cleaning flush out corners prevent deposit build-up in sealing area
- Full bore unrestricted flow area - no seat pockets or cavities
- Bi-directional leak-proof sealing
- 150 psi CWP (10 bar) pressure rating for all sizes
- Stuffing box & gland arrangement ensures leak-proof sealing to atmosphere
- Secondary transverse seal increases the wear life of the primary seal
- Built in PTFE scrapers keep the blade free from any foreign matter over the whole width of the blade during operation
- Yoke design allows for easy mounting of proximity and limit switches and also includes lockouts in both the open and closed position
- The mounting plate is designed to accept manual, pneumatic or electric actuation



**DUCTILE IRON - INSAMCOR® LW
OPEN & CLOSED**

Sealing Principle

In the fully open position the valve seals to atmosphere through a combination stuffing box acting as the primary seal and a secondary transverse seal. The purpose of the secondary seal is to act as a scraper and to extend the life of the primary seal.

As the valve closes the gate remains in contact with the mechanically retained moulded body seal throughout the stroke and is guided by the valve body. When the gate approaches the fully closed position, the angle between

Specifications

	LW - DUCTILE IRON	LW - STAINLESS STEEL
Size Range	2" - 24 " (DN50-DN600)	2" - 24 " (DN50-DN600)
Pressure	150psi CWP (10 bar)	150psi CWP (10 bar)
Test Pressure	Body & Seat tested to 1.1 x CWP	Body & Seat tested to 1.1 x CWP
Body	FBE coated Ductile Iron, or Etch Primed Ductile Iron with SRL faces & bore	CF8M- Stainless Steel
Seals	Molded Nitrile Body Seal	Machined PTFE
Yoke	Fusion Bonded Epoxy Coated	304L Stainless Steel
Gate	304L Stainless Steel	316L Stainless Steel
Flange Drilling	ANSI B16.5 Class 150 AS 2129 Table D & E PN10	ANSI B16.5 Class 150 AS 2129 Table D & E PN10



**STAINLESS STEEL - INSAMCOR® LW
OPEN & CLOSED**

the blade and the flush-out corners create turbulent flow of the media over the seating area. The turbulent flow removes all the sediment from the seat which allows the gate to close on the seating area that is free from any slurry build-up.

When the valve opens the gate again remains in contact with the body seal and the gate is wiped clean by scraper blades that ensure trouble free operation during the next closing cycle.

Optional

Pressure Rating

Refer to Insamcor MH if higher pressure rating is required

Gate

Different gate materials available on request

Actuators

Manual, Manual Bevel Gear, Pneumatic, Electro Mechanical, Hydraulic Hand Lever

Deflector Cones

Replaceable Ni-Hard Wear Cone (NWR)
Polyurethane Deflector Cone (PWR)

Seals

Various Elastomers available

Ports

Vee-Port for Flow Control

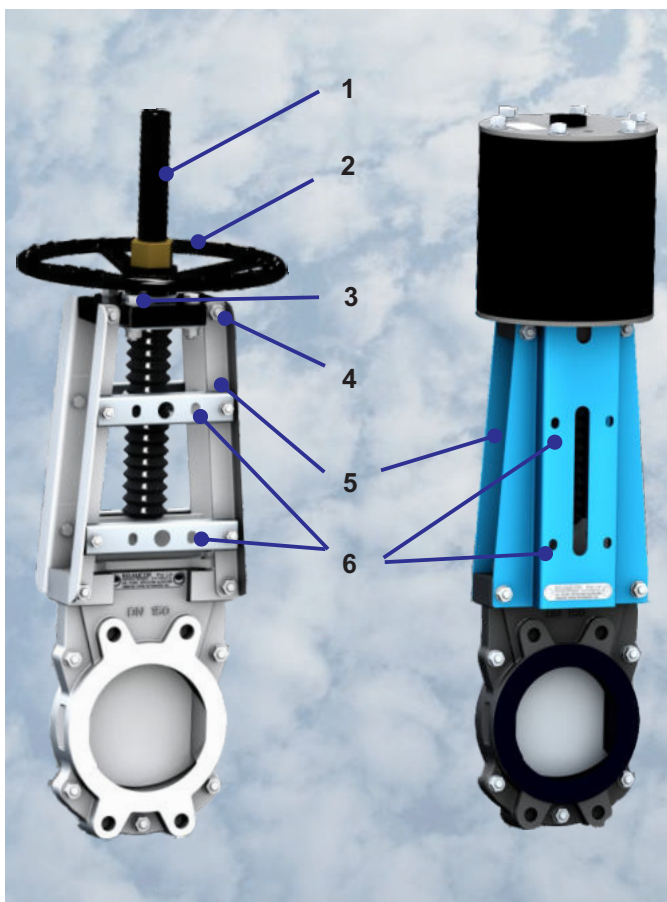

Features

1. **Spindle Cover & Rubber Bellows** - to protect the spindle against slurry splatter
2. **Drive Mechanisms** – pneumatic cylinder, electric, hydraulic cylinder, manual bevel gear and handwheel with rising stem
3. **Thrust Assembly** - all sizes fitted standard with thrust bearings
4. **Mounting Plate** - designed to accept manual, pneumatic or electric actuation without any modification
5. **Yoke** - design allows for easy mounting of proximity switches
6. **Lockout** - provision for lockouts in the open and closed position (standard on all sizes)
7. **Moulded Seal** - mechanically retained resilient moulded seal ensures that the blade is guided throughout its travel and that bi-directional leakproof sealing is obtained
8. **Stuffing Box** - external seal arrangement to atmosphere by means of an external stuffing box arrangement and gland packing
9. **Scrapers** - PTFE scrapers to keep the blade free from any foreign matter over the whole width of the gate during operation
10. **Flushout Corners** - self cleaning flushout corners prevent deposit build up in sealing area
11. **Seat Pockets** - full bore, unrestricted flow area. No valve seat pocket or cavity
12. **Gates** - polished stainless steel gates with bevelled edge at the base to cut through dense media

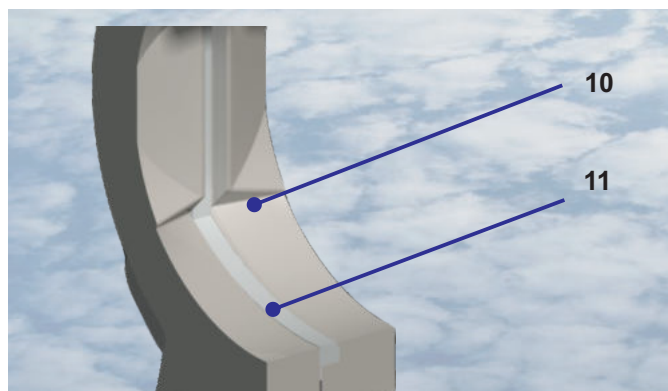
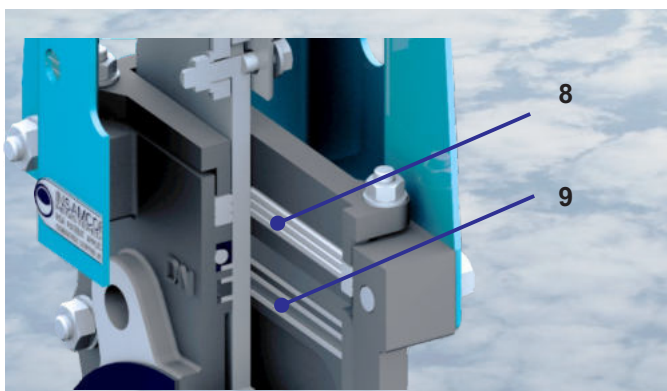
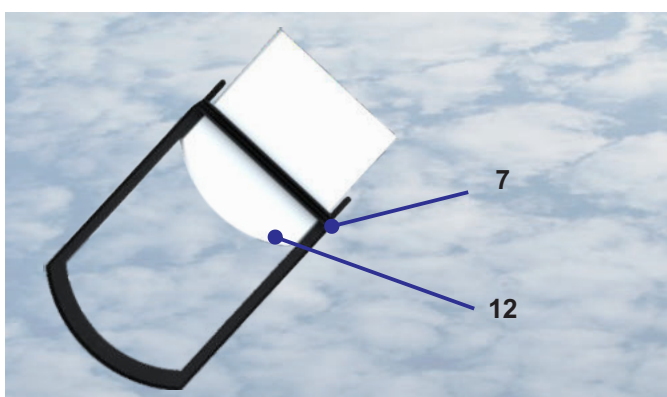

Dimensions and Weights of the Ductile Iron LW

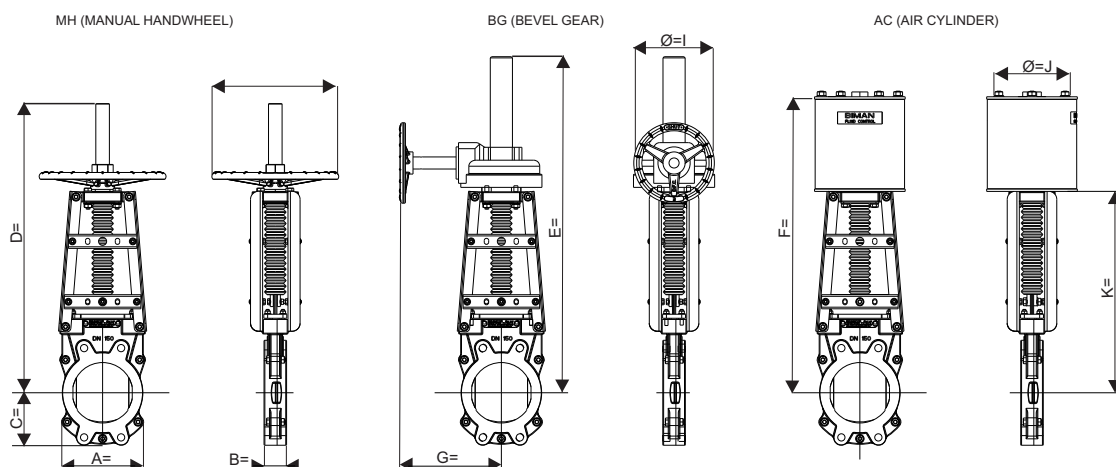

Dimensions (mm) and Weights (kg)

VALVE SIZE	A	B-FBE	B-SRL	C	D	E	F	G	H	I	J	K	WEIGHT MH	WEIGHT BG	WEIGHT AC
50	132	43	49	65	378	500	380.5	303	250	200	100	269.5	12	23	17
65	146	46	52	65	428	500	380.5	303	250	200	100	304	16	26	21
80	126	46	52	89	480	500	484	303	250	200	100	338	15	24	24
100	142	52	58	98	548	568	552	303	250	200	100	386	20	29	27
125	200	56	62	118	448	568	552	303	250	200	160	499	24	33	33
150	200	56	64	130	713	733	715	328	315	300	160	500	29	34	40
200	303	60	68	155	884	1004	874	328	400	300	200	605.5	62	65	83
250	322	68	76	161	1019	1039	1017	328	400	300	250	701	83	85	118
300	374	78	86	187	12347	1254	1185	328	500	400	300	819	102	101	145
350	444	78	86	222	1388	1400	1354	328	500	400	300	937	131	134	194
400	504	100	108	251	1508	1528	1474	328	500	400	400	1009	182	182	263
450	568	114	124	284	1709	1739	1691	351	720	600	450	1190	208	222	336
500	622	127	137	311	1871	1901	1853	351	720	600	450	1282	268	282	396
600	712	154	164	355	2104	2134	2136	351	720	600	550	1480	380	395	517

Dimensions (mm) and Weights (kg)

VALVE SIZE	A	B-FBE	B-SRL	C	D	E	F	G	H	I	J	K	WEIGHT MH	WEIGHT BG	WEIGHT AC
50	5.20	1.69	1.93	2.56	14.88	19.69	14.98	11.93	9.84	7.87	3.94	10.61	26	51	37
65	5.75	1.81	2.05	2.56	16.85	19.69	14.98	11.93	9.84	7.87	3.94	11.97	35	57	46
80	4.96	1.81	2.05	3.50	18.90	19.69	19.06	11.93	9.84	7.87	3.94	13.31	33	53	53
100	5.59	2.05	2.28	3.86	21.57	22.36	21.73	11.93	9.84	7.87	3.94	15.20	44	64	60
125	7.87	2.20	2.44	4.65	17.64	22.36	21.73	11.93	9.84	7.87	6.30	19.65	53	73	73
150	7.87	2.20	2.52	5.12	28.07	28.86	28.15	12.91	12.40	11.81	6.30	19.69	64	75	88
200	11.93	2.36	2.68	6.10	34.80	39.53	34.41	12.91	15.75	11.81	7.87	23.84	137	143	183
250	12.68	2.68	2.99	6.34	40.12	40.91	40.04	12.91	15.75	11.81	9.84	27.60	183	187	260
300	14.72	3.07	3.39	7.36	486.10	49.37	46.65	12.91	19.69	15.75	11.81	32.24	225	223	320
350	17.48	3.07	3.39	8.74	54.65	55.12	53.31	12.91	19.69	15.75	11.81	36.89	289	295	428
400	19.84	3.94	4.25	9.88	59.37	60.16	58.03	12.91	19.69	15.75	15.75	39.72	401	401	580
450	22.36	4.49	4.88	11.18	67.28	68.46	66.57	13.82	28.35	23.62	17.72	46.85	459	489	741
500	24.49	5.00	5.39	12.24	73.66	74.84	72.95	13.82	28.35	23.62	17.72	50.47	591	622	873
600	28.03	6.06	6.46	13.98	82.83	84.02	84.09	13.82	28.35	23.62	21.65	58.27	838	871	1140



Dimensions and Weights of the Stainless Steel LW

MH (MANUAL HANDWHEEL)

BG (BEVEL GEAR)

AC (AIR CYLINDER)

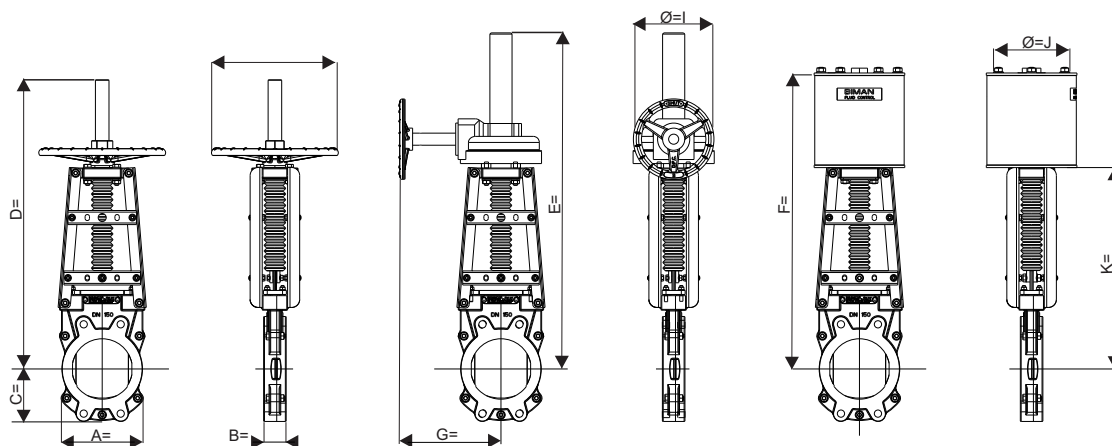

Dimensions (mm) and Weights (kg)

VALVE SIZE	A	B	C	D	E	F	G	H	I	J	K	WEIGHT MH	WEIGHT BG	WEIGHT AC
50	132	43	65	378	500	380.5	303	250	200	100	269.5	12	23	17
65	146	46	65	428	500	380.5	303	250	200	100	304	16	26	21
80	126	46	89	480	500	484	303	250	200	100	338	15	24	24
100	142	52	98	548	568	552	303	250	200	100	386	20	29	27
125	200	56	118	448	568	552	303	250	200	160	499	24	33	33
150	200	56	130	713	733	715	328	315	300	160	500	29	34	40
200	303	60	155	884	1004	874	328	400	300	200	605.5	62	65	83
250	322	68	161	1019	1039	1017	328	400	300	250	701	83	85	118
300	374	78	187	12347	1254	1185	328	500	400	300	819	102	101	145
350	444	78	222	1388	1400	1354	328	500	400	300	937	131	134	194
400	504	100	251	1508	1528	1474	328	500	400	400	1009	182	182	263
450	568	114	284	1709	1739	1691	351	720	600	450	1190	208	222	336
500	622	127	311	1871	1901	1853	351	720	600	450	1282	268	282	396
600	712	154	355	2104	2134	2136	351	720	600	550	1480	380	395	517

Dimensions (mm) and Weights (kg)

VALVE SIZE	A	B	C	D	E	F	G	H	I	J	K	WEIGHT MH	WEIGHT BG	WEIGHT AC
50	5.20	1.69	2.56	14.88	19.69	14.98	11.93	9.84	7.87	3.94	10.61	26	51	37
65	5.75	1.81	2.56	16.85	19.69	14.98	11.93	9.84	7.87	3.94	11.97	35	57	46
80	4.96	1.81	3.50	18.90	19.69	19.06	11.93	9.84	7.87	3.94	13.31	33	53	53
100	5.59	2.05	3.86	21.57	22.36	21.73	11.93	9.84	7.87	3.94	15.20	44	64	60
125	7.87	2.20	4.65	17.64	22.36	21.73	11.93	9.84	7.87	6.30	19.65	53	73	73
150	7.87	2.20	5.12	28.07	28.86	28.15	12.91	12.40	11.81	6.30	19.69	64	75	88
200	11.93	2.36	6.10	34.80	39.53	34.41	12.91	15.75	11.81	7.87	23.84	137	143	183
250	12.68	2.68	6.34	40.12	40.91	40.04	12.91	15.75	11.81	9.84	27.60	183	187	260
300	14.72	3.07	7.36	486.10	49.37	46.65	12.91	19.69	15.75	11.81	32.24	225	223	320
350	17.48	3.07	8.74	54.65	55.12	53.31	12.91	19.69	15.75	11.81	36.89	289	295	428
400	19.84	3.94	9.88	59.37	60.16	58.03	12.91	19.69	15.75	15.75	39.72	401	401	580
450	22.36	4.49	11.18	67.28	68.46	66.57	13.82	28.35	23.62	17.72	46.85	459	489	741
500	24.49	5.00	12.24	73.66	74.84	72.95	13.82	28.35	23.62	17.72	50.47	591	622	873
600	28.03	6.06	13.98	82.83	84.02	84.09	13.82	28.35	23.62	21.65	58.27	838	871	1140

Ductile Iron - Soft Rubber Lined INSAMCOR LW Specification

The knife gate valve will be wafer style and semi lugged with the bore and connecting faces soft rubber lined. The design will allow for bi-directional flow against maximum operating pressure. The body seal must be fully moulded with a lip seal and must be mechanically retained in the valve body. The gate's sides must remain in contact with the body seal during opening and closing of the valve and the gate must be guided by the valve body. The sealing to atmosphere must be through a combination stuffing box acting as the primary seal and a secondary transverse seal. The internal bore will include self-cleaning flush out corners and there will be no seat pockets or cavities in the bore for media to settle in. The valve must incorporate PTFE scrapers to keep the blade free from any foreign matter over the whole width of the gate during operation.

Ductile Iron - Fusion Bonded Epoxy INSAMCOR LW Specification

The knife gate valve will be wafer style and semi lugged with a fusion bonded epoxy coated ductile iron body. The design will allow for bi-directional flow against maximum operating pressure. The body seal must be fully moulded with a lip seal and must be mechanically retained in the valve body. The gate's sides must remain in contact with the body seal during opening and closing of the valve and the gate must be guided by the valve body. The sealing to atmosphere must be through a combination stuffing box acting as the primary seal and secondary transverse seal. The internal bore will include self-cleaning flush out corners and there will be no seat pockets or cavities in the bore for media to settle in. The valve must incorporate PTFE scrapers to keep the blade free from any foreign matter over the whole width of the gate during operation.

Stainless Steel - INSAMCOR LW Specification

The knife gate valve will be wafer style and semi lugged with a CF8M stainless steel body. The design will allow for bi-directional flow against maximum operating pressure. The body seal must be

machined PTFE and must be mechanically retained in the valve body. The gate's sides must remain in contact with the body seal during opening and closing of the valve and the gate must be guided by the valve body. The sealing to atmosphere must be through a stuffing box and gland arrangement. The internal bore will include self-cleaning flush out corners and there will be no seat pockets or cavities in the bore for media to settle in. The valve must incorporate PTFE scrapers to keep the blade free from any foreign matter over the whole width of the gate during operation and PTFE anti-friction pads to keep the gate centralised and eliminate scoring between the gate and the body.

Applications

With a successful history of more than 25 years, Insamcor knife gate valves are suited for a wide variety of industrial applications. DFC has one of the largest installed bases of mineral processing valves in the world and manufacturing facilities in South Africa, Finland and the USA. With sales and support facilities in Australia, North and South America, Europe, Asia, the middle East and Africa, DFC's staff and agents are readily available and committed to solving your problems and providing you with the best possible service wherever your business is located.

Insamcor LW valves are used in a wide array of industries and applications. Examples include

Mining Industry

- Milling & Crushing
- Size Separation - Hydro Cyclones
- Flotation
- Thickening

Coal Fired Power Plants

- Tailings Slurry
- Fly Ash Slurry
- Scrubber Slurry

Other Industries

- Coal Washing
- Steel
- Chemical
- Pulp & Paper

RF Valve® and aiRFlex® pinch valves

The world's most complete line of pinch valves in standard ASME/ANSI B16, DIN and ISO face-to-face dimensions from 1" to 60" (DN25 to DN1500)

- Patented non-stretch, anti-stress folds in all elastomer tubes
- In-line elastomer tube change capability without removing the valve from the pipeline
- Most advanced wear sensing technology for preventative maintenance alert



Insamcor® SKG F & W slurry valves

Heavy duty bi-directional knife gate valve designed for slurry applications

- Flanged & Wafer design available
- Packingless design
- Full port formed by two heavy duty elastomer sleeves
- No seat cavity for unwanted solids to build and prevent gate closure
- No metal parts in contact with flowing media



Saunders® A Type and KB Type diaphragm valves

Simplicity in design coupled with more than 75 years of cutting edge innovation has resulted in the Saunders diaphragm's ability to handle a wider range of fluids than any other valve type

- Available in weir and straight through type
- Available in either flanged or screwed ends
- Various lining and diaphragm material options



DFC manufactures this range under license from Crane CPE and is only available in selected African countries.

Atval, Utility, TruFlo, K & KE Series Pinch Valves

Unequalled performance coupled with long-life and cost effectiveness.

- Sizes: 1" - 32" (25mm - 800mm)
- Designed to accept all forms of Actuators
- Full Bore or Reduced Bore Options
- Working Pressure up to 4000kPa
- Reduces Water Hammer
- All Sleeves available in various Grades and Pressure Ratings



Insamcor® MH slurry valves

Bi-directional high pressure wafer mono-flange knife gate valves suitable for end-of-line installation

- Sizes 2" to 24" (DN50 - DN600)
- Available in 230 psi CWP (16 bar) pressure rating on all sizes
- Combination re-packable primary transverse seal and secondary adjustable stuffing box seal for severe applications
- Mechanically retained moulded seal with no seat pockets
- Gate guided through full length of the stroke



Insamcor® PB ported blade slurry valves

Bi-directional ported blade valve suitable for slurries containing large particles

- Two heavy duty elastomer sleeves are compressed against a ported blade through its entire travel
- The ported blade allows granular slurries of size similar to the blade thickness to be drawn through the seals and flushed out of the valve
- Sizes 2" to 24" (DN50 - DN600)



The Americas Operations

RF Valves Inc.
1342-A Charwood Road
Hanover, MD 21076, USA
Tel: +1-410-850-4404 Fax: +1-410-850-4464
email: contact@rfvalve.com
www: www.rfvalve.com

African Operations

Dynamic Fluid Control (Pty) Ltd
32 Lincoln Road,
Industrial Sites, Benoni South, South Africa
Tel: +27-11-748-0200 Fax: +27-11-421-2749
email: dfc@dfc.co.za
www: www.dfc.co.za

Australian Operations - NSW

5 Vangel St, Arndell Park, NSW, 2148
P.O. Box 156, Seven Hills, NSW, 1730
Tel: +61-2-8814-9699
Fax: +61-2-8814-9666
Email: sales@ventomat.com.au
Website: www.ventomat.com.au

European Operations

RF Valves, Oy.
Tullitie 9,
53500 Lappeenranta, Finland
Tel: +358-20-758-1790 Fax: +358-20-785-1799
email: rfvalves@rftek.fi
www: www.rfvalve.com

Brazil Operations

Industria e Comercio de Valvulas do Brasil Ltda
Address: Rua Álvaro da Silveira, 40 - Santa Margarida
Belo Horizonte - Minas Gerais, Brasil
Tel : +55-31-3658-3656
Email address: rfq@rfvalve.com
www: www.rfvalve.com