



MACNEIL STEEL AND VALVES (PTY) LTD



MSV CL2C LIGHT  
INDUSTRIAL PATTERN  
WEDGE GATE VALVE  
RISING SPINDLE  
PN10/PN16

+27 (011) 822 1802

[www.msv.co.za](http://www.msv.co.za)

1575 Staal Rd, Knights,  
Germiston, Gauteng, SA



MACNFII STEEL AND VALVES (PTY) LTD

**MSV CL2C LIGHT INDUSTRIAL PATTERN WEDGE GATE VALVE,  
RISING SPINDLE, PN10/PN16, EPOXY COATED DUCTILE IRON  
BODY, FLANGED, HANDWHEEL OPERATED**

**SPECIFICATIONS:**

- Epoxy Coated Cast Iron Body
- Rising spindle
- PN10 / PN16
- Brass Seats
- Flanged T1000 or Un-drilled
- Hand wheel operated
- Clockwise Closing

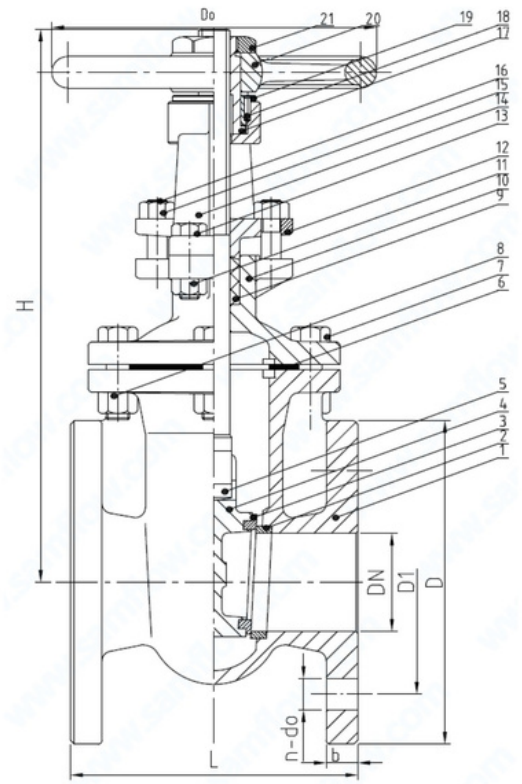

NO.	PART	MATERIAL	QTY
1	Body	GG25 Cast Iron	1
2	Body Ring	Bronze	2
3	Disc Ring	Bronze	2
4	Disc	GG25 Cast Iron	1
5	Stem	2CR13	1
6	Gasket	Graphite	1
7	Bolt	Steel	6
8	Nut	Steel	6
9	Packing	Graphite	1
10	Bonnet	GG25 Cast Iron	1
11	Nut	Steel	4
12	Gland	GGG50	1
13	Bolt	Steel	4
14	Yoke	GG25 Cast Iron	1
15	Nut	Steel	2
16	Bolt	Steel	2
17	Stem Nut	Steel	1
18	Pin	Steel	1
19	Round Lock Nut	Steel	1
20	Hand Wheel	GG25 Cast Iron	1
21	Hand Wheel Nut	GG25 Cast Iron	1

PERFORMANCE STANDARD		
Nominal Pressure (MPa)	1.6	
Testing Pressure (MPa)	Body Shell	2.4
	Seal	1.7
Working Pressure (MPa)	1.6	
Suitable Temperature	+/- 80 °C	
Suitable Medium	Raw Sewage / Water	



DN	L	H	Do	D	D1	b	n-do	Torque	Weight (Kg)
50mm	146	297	165	165	125	16	4-18	60	16
65mm	159	333	165	185	145	16	4-18	78	
80mm	165	390	195	200	160	18	8-18	96	27
100mm	171	466	242	220	180	18	8-18	120	36
125mm	190	530	268	250	210	20	8-18	150	48
150mm	210	640	292	285	240	20	8-23	180	68
200mm	241	763	345	340	295	22	8-23	240	111
250mm	273	903	376	405	350	24	12-23	300	148
300mm	305	1053	450	460	400	26	12-23	360	208

+27 (011) 822 1802

www.msv.co.za

1575 Staal Rd, Knights,  
Germiston, Gauteng, SA

**MSV CL2C LIGHT INDUSTRIAL PATTERN WEDGE GATE VALVE RISING SPINDLE  
PN10/PN16**