

VENT-O-MAT

SERIES NCV-B & NCV-BK

**NON-SLAM HIGH PERFORMANCE
NOZZLE CHECK VALVES**

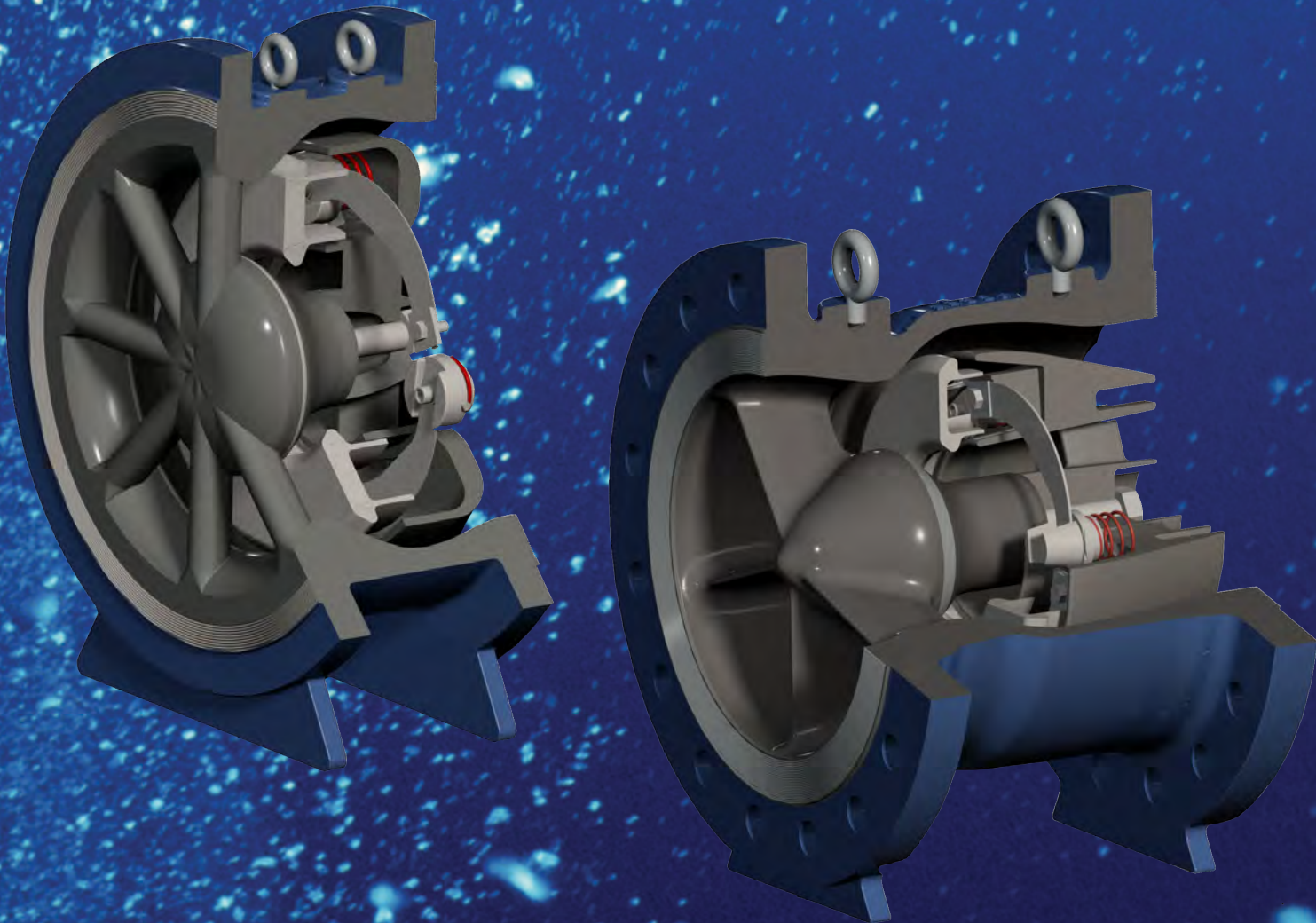

NON SLAM HIGH PERFORMANCE CHECK VALVES



Vent-O-Mat® NCV-B

Incorrect check valve selection can aggravate surge and water-hammer in pipeline systems, resulting in what is known as “Check Valve Slam” causing transients which could exceed the pipeline’s working pressure by up to five times. Check valves can also be one of the biggest contributors to head loss within a pipeline, which in turn increases power consumption. Vent-O-Mat’s range of nozzle check valves addresses both these concerns by providing a non-slam valve with a very low pressure loss.

The valve utilises a ring-shaped disc as the closing member. Rapid slam-free closure is achieved utilising friction free helical springs and radial guides. Annular ring type nozzle check valves outperform center shaft nozzle designs (mushroom type) in respect of dynamic and head loss performance because of the low mass of the moving parts (ring shaped disc) and the superior pressure recovery capabilities inherent in the two-port annulus configuration.

Design Features and Advantages

- Non-slam closure - the valve responds rapidly to changes in velocity that the disc is at the point of closure before reverse flow occurs
- Low pressure loss - in the open position the annular disc forms two flow paths which increases the volume of flow through the valve
- Short closure time - the short stroke length reduces closure time
- Friction free opening and closing - helical springs and radial guides allow the disc to move from the open to closed position with limited resistance
- Tight shut off - achieved by metal - to - metal sealing
- No scheduled maintenance



Vent-O-Mat® NCV-BK

NCV-B

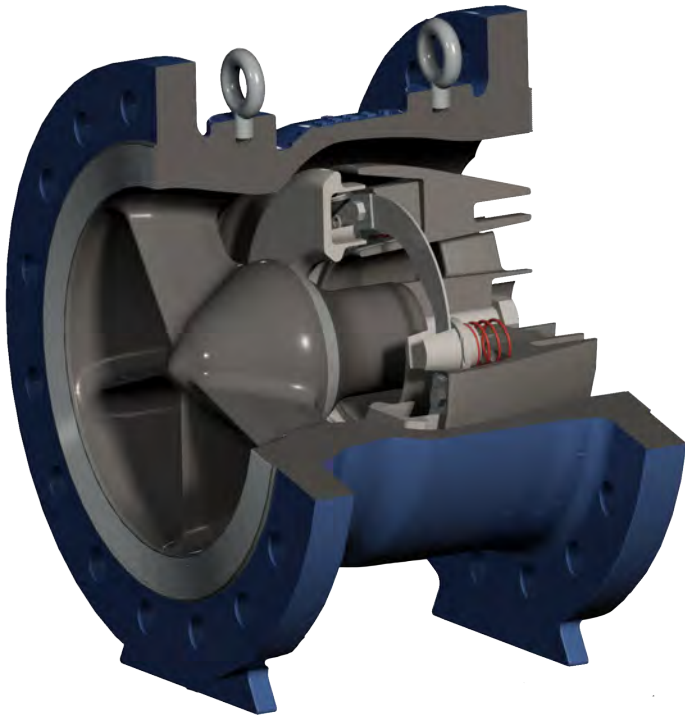

- Non-slam closure
- Extremely quick closure
- Very low pressure loss
- Tight shut off
- No resilient seats
- Maintenance free
- DN200 (8") to DN1200 (48")
- PN10 to PN40 / ANSI 150 to ANSI 300

Face-to-Face Dimensions (mm/inches) and Weights (kg/lbs)

| Valve Size | | Face-to-Face | | Weight PN10-PN16 | | Weight PN25 | | Weight PN40 | | Weight ANSI 300 | |
|------------|------|--------------|------|---------------------|------|----------------|-------|----------------|-------|--------------------|-------|
| mm | inch | mm | inch | kg | lbs | kg | lbs | kg | lbs | kg | lbs |
| 200 | 8 | 230 | 9.1 | 145 | 320 | 150 | 330 | 160 | 355 | 180 | 400 |
| 250 | 10 | 290 | 11.4 | 165 | 365 | 160 | 355 | 180 | 400 | 200 | 440 |
| 300 | 12 | 350 | 13.8 | 180 | 395 | 190 | 420 | 225 | 500 | 245 | 540 |
| 350 | 14 | 405 | 16.0 | 315 | 695 | 280 | 620 | 325 | 720 | 365 | 805 |
| 400 | 16 | 455 | 17.9 | 415 | 915 | 365 | 405 | 430 | 950 | 490 | 1080 |
| 450 | 18 | 520 | 20.5 | 480 | 1060 | 525 | 1160 | 575 | 1270 | 685 | 1510 |
| 500 | 20 | 570 | 22.4 | 540 | 1190 | 565 | 1245 | 630 | 1390 | 720 | 1590 |
| 600 | 24 | 685 | 27.0 | 900 | 1985 | 935 | 2065 | 1050 | 2315 | 1340 | 1955 |
| 700 | 28 | 800 | 31.5 | 1305 | 2875 | 1490 | 3285 | 1650 | 3640 | 1980 | 4365 |
| 800 | 32 | 910 | 35.8 | 1700 | 3750 | 1800 | 3970 | 2150 | 4740 | 2360 | 5205 |
| 900 | 36 | 1030 | 40.6 | 2430 | 5360 | 2885 | 6360 | 3300 | 7275 | 3570 | 7870 |
| 1000 | 40 | 1135 | 44.7 | 3240 | 7145 | 3500 | 7720 | 3950 | 8710 | 4080 | 9000 |
| 1200 | 48 | 1365 | 53.7 | 4320 | 9525 | 5220 | 11510 | 5800 | 12790 | 6000 | 13230 |

NON SLAM HIGH PERFORMANCE CHECK VALVES

NCV-BK

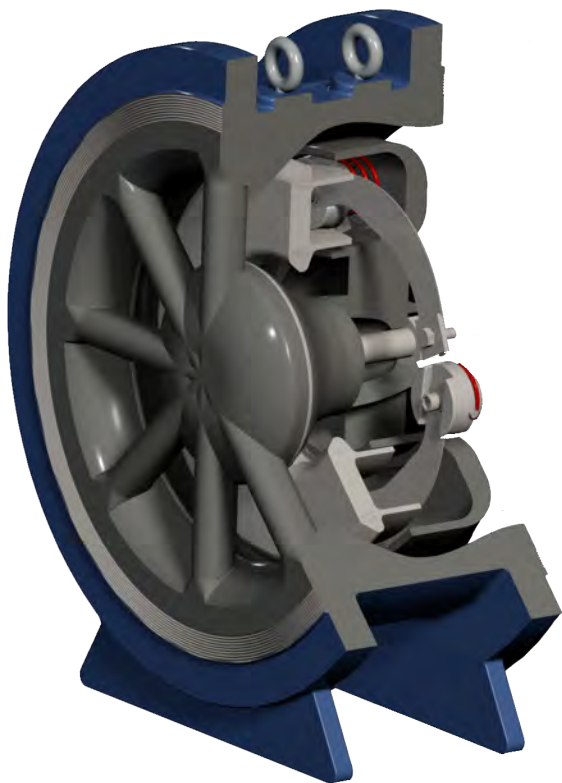

- Economical short face-to-face
- Non-slam closure
- Extremely quick closure
- Low pressure loss
- Tight shut off
- No resilient seats
- Maintenance free
- DN200 (8") to DN1200 (48")
- PN10 to PN40 / ANSI 150 to ANSI 300

Face-to-Face Dimensions (mm/inches) and Weights (kg/lbs)

| Valve Size | | Face-to-Face | | Weight PN10-PN16 | | Weight PN25 | | Weight PN40 | | Weight ANSI 300 | |
|------------|------|--------------|------|------------------|------|-------------|------|-------------|------|-----------------|------|
| mm | inch | mm | inch | kg | lbs | kg | lbs | kg | lbs | kg | lbs |
| 200 | 8 | 121 | 4.8 | 65 | 145 | 75 | 165 | 85 | 190 | 105 | 235 |
| 250 | 10 | 151 | 6.0 | 70 | 155 | 85 | 190 | 100 | 220 | 140 | 310 |
| 300 | 12 | 181 | 7.1 | 95 | 210 | 100 | 220 | 130 | 290 | 150 | 330 |
| 350 | 14 | 215 | 8.5 | 135 | 300 | 145 | 320 | 185 | 410 | 225 | 500 |
| 400 | 16 | 245 | 9.7 | 185 | 410 | 210 | 465 | 270 | 595 | 320 | 705 |
| 450 | 18 | 264 | 10.4 | 295 | 650 | 325 | 720 | 365 | 805 | 455 | 1005 |
| 500 | 20 | 305 | 12.0 | 365 | 805 | 380 | 840 | 420 | 925 | 510 | 1125 |
| 600 | 24 | 370 | 14.6 | 580 | 1280 | 600 | 1325 | 720 | 1590 | 810 | 1785 |
| 700 | 28 | 430 | 16.9 | 745 | 1645 | 780 | 1720 | 940 | 2075 | 1230 | 2715 |
| 800 | 32 | 500 | 19.7 | 1000 | 2205 | 1100 | 2425 | 1250 | 2755 | 1460 | 3220 |
| 900 | 36 | 560 | 22.1 | 1550 | 3420 | 1380 | 3045 | 1800 | 3970 | 2070 | 4565 |
| 1000 | 40 | 680 | 25.6 | 2000 | 4410 | 1730 | 3815 | 2180 | 4810 | 2310 | 5095 |
| 1200 | 48 | 740 | 29.1 | 2800 | 6175 | 2870 | 6330 | 3450 | 7605 | 3500 | 7720 |

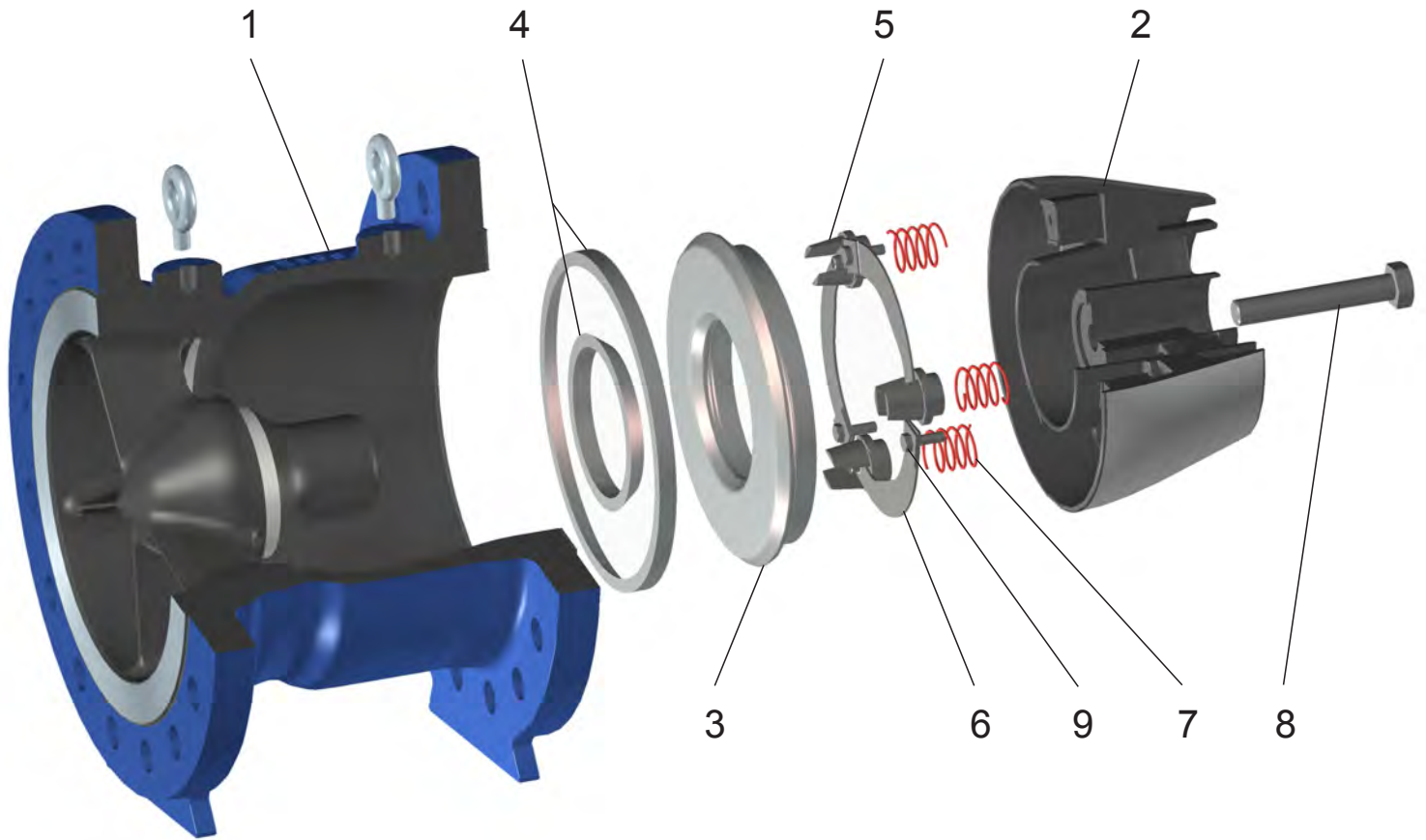

| ITEM | DESCRIPTION | MATERIAL | | |
|------|----------------|--------------------|-------------------|-------------------|
| | | DUCTILE IRON | CAST STEEL | STAINLESS STEEL |
| 1 | VALVE BODY | ASTM A536 65-45-12 | ASTM A216 WCB | ASTM A350 CF8M |
| 2 | FLOW DIFFUSER | ASTM A536 65-45-12 | ASTM A216 WCB | ASTM A350 CF8M |
| 3 | VALVE DISC | ASTM A350 CF8M | ASTM A350 CF8M | ASTM A350 CF8M |
| 4* | SEAT RINGS | AISI 316 | AISI 316 | AISI 316 |
| 5 | SPRING GUIDE | AISI 316 | AISI 316 | AISI 316 |
| 6 | RADIAL GUIDE | AISI 420 3/4 HARD | AISI 420 3/4 HARD | AISI 420 3/4 HARD |
| 7 | HELICAL SPRING | ASTM A313-98 | ASTM A313-98 | ASTM A313-98 |
| 8 | TIE BOLT | ASTM A193 B8M | ASTM A193 B8M | ASTM A193 B8M |
| 9 | FASTENERS | ASTM A193 B8M | ASTM A193 B8M | ASTM A193 B8M |

* Sizes DN250 (10") and smaller are available with seat rings only. Sizes DN300 (10") and larger are available with seat rings or deposit welded seats

NON SLAM HIGH PERFORMANCE CHECK VALVES

Optional

Pressure Rating

Pressure ratings higher than 50bar / ANSI 300

Seats

Seat rings in bronze, duplex and stainless steel or deposit welding in stainless steel

Body Materials

Aluminium-Bronze, Duplex or Super duplex

Springs

Different spring designs for vertical applications and other system requirements

Specification

The non-slam check valve will be double flanged and of a nozzle type design. The closing disc must have a ring-shaped design to minimise the mass of the moving parts. The disc must be guided utilising friction free stainless steel helical springs and radial guides to ensure rapid slam free closure. The valve must fully open at low flow rates to minimise pressure drop during normal operating conditions and respond rapidly to changes in velocity that the disc is at the point of closure before reverse flow occurs. The valve body and diffuser design must create a venturi shape to create a pressure differential across the disc to assist in opening the valve and ensuring a high pressure recovery resulting in a low pressure drop across the valve.

Applications

- Bulk water
- Pumping Stations
- Desalination plants
- Water distribution plants
- Chemical plants
- Coal fired power stations



DN350 NCV- BODY SEAT MACHINING



DN900 (36") PN25 NCV-B FLANGE MACHINING



DN400 (16") PN25 NCV-B

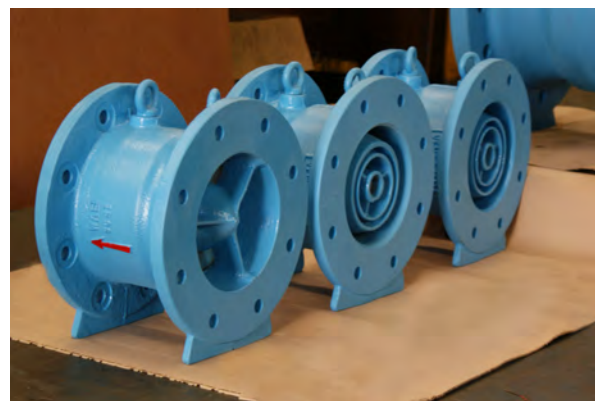

DN200 (8") NCV-B

1. DEFINITIONS

- 1.1 Seller:
Dynamic Fluid Control (Pty) Ltd
- 1.2 Purchaser:
The party who places an order on the Seller, which is accepted by the Seller in terms of Clause 2. (such acceptance hereinafter being referred to as "Acceptance of Order").
- 1.3 Goods
The materials, products and/or services ordered by the Purchaser and accepted by the Seller in terms of Clause 2, Contract.
These General Conditions of Tender and Sale, technical specifications of the Purchaser's order as have been specifically agreed in writing and the Acceptance of Order, together with only such other terms and conditions as may be specifically agreed in writing between the parties.

2. ACCEPTANCE OF ORDER

- 2.1 The Purchaser's order shall constitute an offer, and a contract shall only come into existence when the Seller accepts the Purchaser's order, by issuing an Acceptance of Order or by performing in response to the Order. Unless otherwise specifically agreed in writing in the contract any other terms and conditions including those forming part of the Purchaser's order, which deviate from the General Conditions, shall not form part of the Contract, and shall be of no force or effect.
- 2.2 In the event that the Purchaser and the Seller engage in negotiations over amendments or additions to or deletions from the General Conditions of Tender and Sale, these General Conditions shall govern the sale of the goods until such negotiations are finalised and these General Conditions amended (if at all) by agreement in writing.

3. SCOPE OF CONTRACT

The Seller's obligations in terms of the Contract will be to produce the Goods in accordance with such designs, instructions, itemised details, plans, drawings, programmes and specifications (the specifications) as form part of the Contract, and in particular the Seller will not be responsible for the adequacy of or for any costs occasioned by the inadequacy of any such specifications or for any foundations or supporting structures of other work as may have been provided, prepared or specified by or on behalf of the Purchaser.

4. LIABILITY

- 4.1 **Liability for Defects**
The Seller undertakes that the Goods will conform to such specifications in respect of each other as have been specifically accepted by the Seller in writing and in the event of the Goods proving not to be in accordance with such specifications, the Seller shall, if requested to do so in writing within a reasonable time of discovery of such failure to conform to such specifications (hereinafter referred to as defects), but not in any event after 6 months have elapsed from the date of delivery of such defective Goods to the Purchaser, at its option, repair or replace the defective portions/components of the Goods, by supplying the repaired or replacement portion components of the Goods to the initial place of delivery, or at the further option of the Seller, to credit the Purchaser with the invoice value of the defective portion/components of the Goods in question. Notwithstanding anything to the contrary anywhere contained, the Seller shall have no liability in respect of any defects in the Goods, whether latent or patent, not notified to the Seller in writing before the end of the aforesaid 6 month period.
- 4.2 **Liability for Delay**
Subject to the provisions of Clause 8 and 10, the Seller undertakes to supply the Goods in accordance with such delivery dates as are specifically agreed in contract, and in the event that the Goods are not supplied in accordance with such dates, or within extensions or revisions of such dates, or if delays caused by the discovery of defects after delivery, the Seller's liability shall be limited to such penalty for late delivery as may have been specifically accepted by the Seller in writing in respect of each order accepted by the Seller. Such penalty shall only be payable in the event that, and to the extent that, the Purchaser is himself legally obliged to pay penalties in respect of each delay and in no event shall such penalty exceed 10% of the unescalated Contract Price of such portions of the Goods as cannot, because of the delay, be put to the use intended, and such penalty shall constitute the Seller's sole liability and the Purchaser's sole remedy for such delay.
- 4.3 Notwithstanding anything to the contrary anywhere contained, the liability of the Seller howsoever arising out of the Contract or in Delict or by operation of statute shall not extend beyond the obligations specifically assumed in terms of this Clause 4, and the Seller.
- 4.3.1 gives no other warranties, expressed or implied in respect of (without limitation) workmanship, materials, fitness for purpose, merchantability or products liability not set out herein;
- 4.3.2 in respect of "brought out" or proprietary items not of its own manufacture, gives no greater warranty and accepts no greater liability than that given or accepted by and enforceable against the supplier/manufacturer thereof.
- 4.3.3 gives no warranties in respect of Goods used other than for the intended purpose, or for defects arising through fair wear and tear or neglect, shall in no event be liable for the Purchaser's loss of profits, loss of use, loss of production, loss of custom or goodwill, or for any special, indirect or consequential damages howsoever arising.

5. DELIVERY

- 5.1 Unless otherwise stipulated in the Contract, delivery shall be "ex Seller's works" and the Contract Price is based on such "ex works" delivery and is exclusive of any sales tax payable in terms of any applicable statute, packaging, freight and insurance during transport.
- 5.2 The risk in and to the Goods will pass to the Purchaser on Delivery and claims for non delivery or for shortages or damage upon receipt of the Goods must be made in writing by the Purchaser within the earlier of 7 (seven) days of the relevant consignment note or receipt of the Goods as the case may be, failing which the Seller shall have no liability in respect of such claims.
Should the Purchaser fail or refuse to take delivery of the Goods when delivery is tendered by the Seller, the Purchaser shall be liable for such costs as may be incurred by the Seller as consequence thereof.

6. Contract Price

- Unless otherwise specifically agreed in writing in each particular instance:
- 6.1 the contract price to be paid by the Purchaser for the Goods shall be as set out in the tender and is based on the costs of materials, transport, labour, insurance rates, exchange rates and import duties ruling at the date of the tender and any variation in such costs or rates occurring between the date of the tender and the date of payment, shall be for the account of the Purchaser, and shall be determined in accordance with the formula included in the Contract, and if no formula is so included, in accordance with the prevailing relevant formulae, principles and indices published by SEIFSA.
- 6.2 If the Goods or any parts thereof are to be imported, the price will be based on the rates of exchange, freight, insurance premiums, lightage, landing charges, port dues, custom duty and railage at the date of tender, or as specifically agreed. Should these rates vary between the date of the tender and the date upon which charges are incurred, the price shall be varied by the amount of the increase or decrease in such charges.

- 6.3 the Contract Price shall be paid in cash, free of exchange, deduction or set off within 30 (thirty) days of the date of Seller's statement, provided that in any event, notwithstanding delivery of the Goods to the Purchaser or to any third party, it is specifically agreed that it is the intention of the parties that the Goods shall not accede to any other property, whether moveable or immovable, and that it is as far as any other goods or equipment are concerned the Goods shall, for the purposes of accession be deemed to be the Principle items, and that ownership of the goods and any items accessory thereto shall at all times remain vested in the Seller, and shall not pass to the Purchaser until the full Contract Price has been paid. In the event of non-payment, the Purchaser hereby irrevocably authorises the Seller or its duly authorised agents to repossess the Goods wheresoever they may be found, and further, at its option, in detach or unmix by itself, its agents or servants, the Goods from anything to which they are attached or in which they are installed or annexed without being responsible for any damage that may be caused thereby and may, for such purpose, by itself, its servants or agents, enter upon any land or building, vehicle or vessel or other place upon which the Goods are reasonably thought to be situated.

- 6.4 Payments delayed after the due date for payment shall be subject to interest charges, compounded monthly with effect from the date of delivery, at prime bank overdraft rate.

- 6.5 Where payment by the Purchaser is effected by cheque, and where the post is used the risk of loss arising from the use of a cheque or the use of the post, shall rest with the Purchaser.

7. RENUNCIATION OF BENEFITS

The Purchaser hereby renounces the benefits of any other rights; not expressly referred to in these General Conditions are not expressly agreed in writing and to which it may be entitled, or which it may acquire in terms of the Agricultural Credit Act, 28 of 1966 as amended, the Moratorium Act. 25 of 1963 or any other similar rights under any other statute.

8. VARIATIONS

The Seller shall supply the Goods strictly in accordance with the Contract. Should the Purchaser require variations to the Goods, or to the quantities thereof, or should the Seller be hindered, delayed or prevented from supplying in terms of the Contract or be exposed to extra cost owing to extensions or to emissions from the order, deviations from the specifications, late, defective or non-receipt of information or rep issue materials or by any other act, default or omission by or on behalf of the Purchaser, the Seller shall be entitled to an appropriate variation to the rates or to the Contract Price or to the programme, or any other obligation of the Seller, provided that no such variation required by the Purchaser shall, without the written consent of the Seller, together with such other variations as may have been requested, involve a variation of more than 10% (ten per centum) to the Contract Price or to the quantities set out in the Contract.

9. RETURNS

Returns, if accepted by the Seller at its sole discretion and upon such terms as it may prescribe, shall be credited Subject to a deduction of a minimum of 10% (ten per centum) as a handling charge, subject to the goods being within their specified shelf life and in a marketable condition and provided further that the Purchaser shall be liable for all costs of delivery to the Seller's designated premises.

10. FORCE MAJEURE

- 10.1 Neither party shall be liable to the other for inability to perform or delayed performances in terms of the Contract, should such inability delay arise from any cause beyond the reasonable control of such party, the existence or happening of which cause has been drawn to the attention of the other party within a reasonable time of the occurrence of such cause (hereinafter referred to as "a Force Majeure event").
- 10.2 For the purposes of this clause a Force Majeure event shall, without limitation to the generality of (the foregoing, be defined to include, strikes, lock outs, labour disputes, accidents, plant and machinery breakdowns, fire, explosions, theft, war (whether declared or not) invasion, acts of foreign enemies, hostilities, riot, civil insurrection, flood, earthquake, lightning, act of local or national government, martial law, failure or delay or, the part of the Seller's supplier(s) of service, of "bought out" or raw materials, to meet delivery dates, or any failure or delay on the part of the Purchaser or the Purchaser's agents or other Contractors to provide the Seller with free issue materials, specifications, or defects or changes in such Specifications, or any other cause beyond the reasonable control of the party effected.

11. PATENTS COPYRIGHT AND CONFIDENTIALITY

- 11.1 The Purchaser shall indemnify and hold harmless the Seller against all claims and expenses of whatsoever nature and description arising from alleged or infringement of any Letters Patent, Trade Mark, Designs or Copyright occasioned by the Seller's performance of this Contract.
- 11.2 The Seller warrants however that any designs specified by it shall not infringe any of such Letters Patent, Trade Marks, Designs or Copyright.
- 11.3 The Purchaser shall keep confidential and shall not use for any purpose other than the Contract itself, all drawings and designs supplied by the Seller in terms of the Contract, and the Purchaser shall indemnify the Seller against any loss suffered by the Seller as a result of the breach of this clause. Such drawings and designs supplied by the Seller remains the exclusive property of the Seller and shall be promptly delivered and returned to the Company upon completion of the Contract.

12. BREACH

Should either party be in breach of any material obligations imposed in terms of the Contract and fail to remedy such breach or take positive steps towards remedying such breach within 14 (fourteen) days of written notice of such breach from the other party, then the non defaulting party shall be entitled to cancel the Contract, without prejudice to such other rights that such non defaulting party may have in terms of this agreement or at law.

13. GOVERNING LAW AND DISPUTES

- 13.1 The Contract shall be construed and interpreted in accordance with, the laws of the Republic of South Africa.
- 13.2 Any disputes arising between the parties in respect of the Contract shall, at the option of the Seller, be justiciable in the Magistrates Court of South Africa having jurisdiction over the Purchaser, notwithstanding the fact that the dispute might otherwise have fallen outside the jurisdiction of such Magistrates Court and the Purchaser to such jurisdiction.

14. FUTURE CONTRACTS

These General Conditions of Tender and Sale (as they may be amended from time to time by the Seller shall also apply to any future, oral or written contract for the supply of goods and/or services by the Seller to the Purchaser, save to the extent that such conditions are in any future contracts specifically varied or excluded or are inconsistent with what is expressly agreed in any such future contract.

15. LANGUAGE

These General Conditions of Tender and Sale are available in the other official language, upon request.

Dynamic Fluid Control (Pty) Ltd
P O Box 5064
Benoni South
1502
South Africa

Tel:- 27 11 748 0200

Fax:- 27 11 421 2749

dfc@dfc.co.za

www.ventomat.com

Revision Date Nov 2012 Catalogue NCV0001