

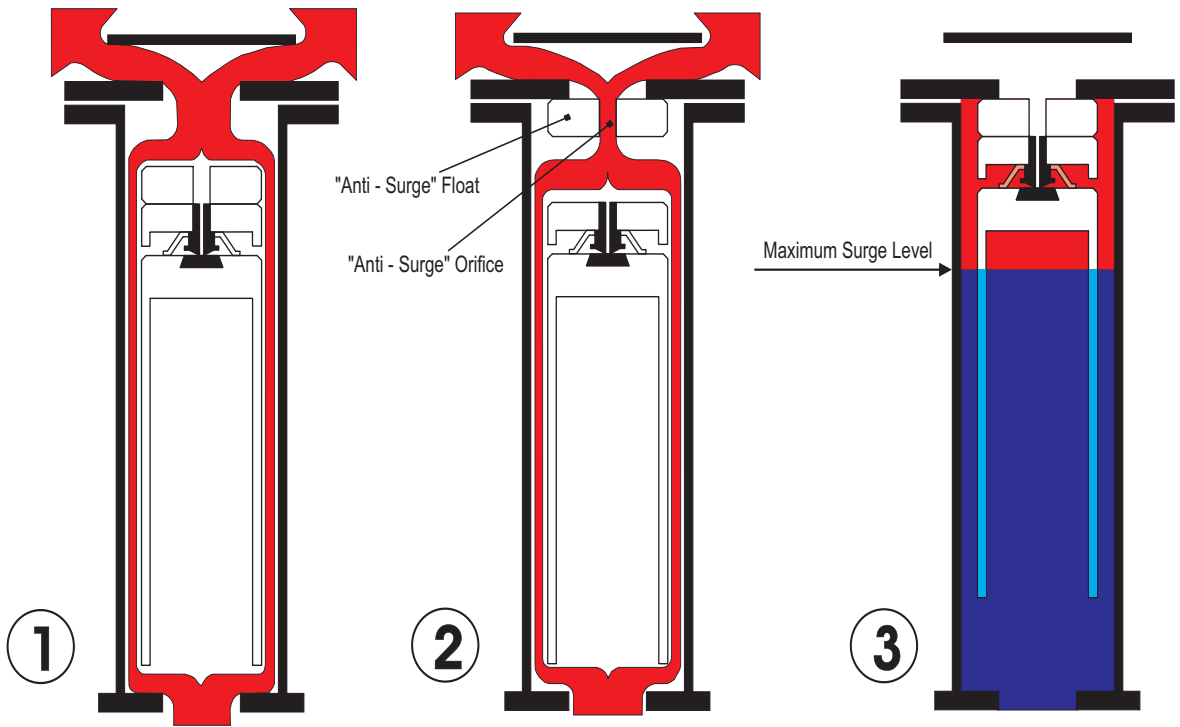

CATALOGUE INDEX

CONTENT	PAGE
OPERATION -SERIES RGX	1 - 2
RECOMMENDED INSTALLATION ARRANGEMENTS -SERIES RGX	3
AVAILABLE DISCHARGE CONNECTIONS -SERIES RGX	4
COMPONENT DESCRIPTION & MATERIAL SPECIFICATIONS - SERIES RGX DN50 (2") - DN100 (4") - Flanged	5
COMPONENT DESCRIPTION & MATERIAL SPECIFICATIONS - SERIES RGX DN50 (2") - DN100 (4") - Flanged (Expanded Body)	6
COMPONENT DESCRIPTION & MATERIAL SPECIFICATIONS - SERIES RGX DN150 (6") & DN200 (8") - Flanged	7
COMPONENT DESCRIPTION & MATERIAL SPECIFICATIONS - SERIES RGX DN150 (6") & DN200 (8") - Flanged (Expanded Body)	8
GENERAL SPECIFICATIONS - SERIES RGX DN50 (2") - DN200 (8") - Flanged	9
GENERAL SPECIFICATIONS - SERIES RGX DN50 (2") - DN200 (8") - Flanged (Expanded Body)	10
SELECTION & POSITIONING - SERIES RGX	11 - 12
SURGE & WATERHAMMER PROTECTION SERIES RGX	13 - 14
SMALL ORIFICE DISCHARGE PERFORMANCE	15
WHY VENT-O-MAT SERIES RGX?	16
PURCHASE SPECIFICATIONS - SERIES RGX	17
ORDERING GUIDE & TEST SPECIFICATIONS - SERIES RGX	18
OPERATION - SERIES RGXb	19 - 20
RECOMMENDED INSTALLATION ARRANGEMENTS - SERIES RGXb	21
COMPONENT DESCRIPTION & MATERIAL SPECIFICATIONS - SERIES RGXb DN50 (2") - DN100 (4") - Flanged	22
COMPONENT DESCRIPTION & MATERIAL SPECIFICATIONS - SERIES RGXb DN50 (2") - DN100 (4") - Flanged (Expanded Body)	23
COMPONENT DESCRIPTION & MATERIAL SPECIFICATIONS - SERIES RGXb DN150 (6") & DN200 (8") - Flanged	24
COMPONENT DESCRIPTION & MATERIAL SPECIFICATIONS - SERIES RGXb DN150 (6") & DN200 (8") - Flanged (Expanded Body)	25
GENERAL SPECIFICATIONS - SERIES RGXb DN50 (2") - DN200 (8") - Flanged	26
GENERAL SPECIFICATIONS - SERIES RGXb DN50 (2") - DN200 (8") - Flanged (Expanded Body)	27
PURCHASE SPECIFICATIONS - SERIES RGXb	28
OPERATION - SERIES RGXv	29 - 30
COMPONENT DESCRIPTION & MATERIAL SPECIFICATIONS - SERIES RGXv DN50 (2") - DN100 (4") - Flanged	31
COMPONENT DESCRIPTION & MATERIAL SPECIFICATIONS - SERIES RGXv DN50 (2") - DN100 (4") - Flanged (Expanded Body)	32
COMPONENT DESCRIPTION & MATERIAL SPECIFICATIONS - SERIES RGXv DN150 (6") & DN200 (8") - Flanged	33
COMPONENT DESCRIPTION & MATERIAL SPECIFICATIONS - SERIES RGXv DN150 (6") & DN200 (8") - Flanged (Expanded Body)	34
GENERAL SPECIFICATIONS - SERIES RGXv DN50 (2") - DN200 (8") - Flanged	35
GENERAL SPECIFICATIONS - SERIES RGXv DN50 (2") - DN200 (8") - Flanged (Expanded Body)	36
PURCHASE SPECIFICATIONS - SERIES RGXv	37
ORDERING GUIDE - SERIES RGXb & RGXv	38

Series RGX OPERATION



**PIPELINE FILLING
(SUB CRITICAL SEWAGE/ EFFLUENT
APPROACH VELOCITY)**

**PIPELINE FILLING
(EXCESSIVE SEWAGE/ EFFLUENT
APPROACH VELOCITY)**

PIPELINE FULLY CHARGED

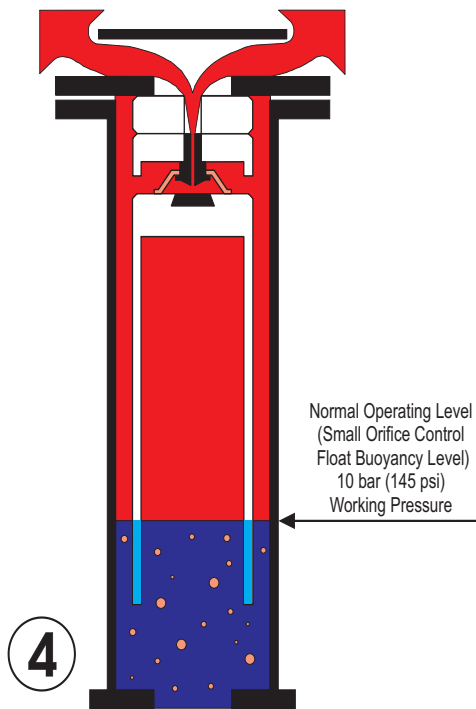

**PRESSURIZED AIR/GAS RELEASE
PIPELINE OPERATING**

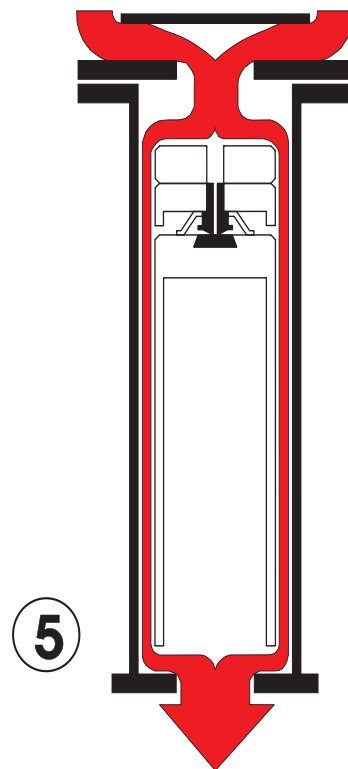

**VACUUM RELIEF (AIR INTAKE)
PIPELINE DRAINING**

Series RGX

OPERATION

PRE NOTES:

A) VENTING OF A FILLING PIPELINE:

The operation of a conventional sewage air release valve is such that fast approaching sewage/effluent is almost instantaneously halted by the valve's closure. Consequently a transient pressure rise or shock of potentially damaging proportions can be generated in a pipeline system, even at normal filling rates.

In addition to venting through the Large Orifice when sewage/ effluent approach velocities are sub critical, the Vent -O- Mat series RGX sewage air release valves feature an automatic "Anti - Surge" Orifice device that serves to decelerate sewage/ effluent approaching at excessive speed, thereby limiting pressure rise in the pipeline.

B) SURGE ALLEVIATION - PIPELINE PRESSURIZED:

In instances where a pipeline experiences liquid column separation due to pump stoppage, high shock pressures can be generated when the separated column rejoins.

The Vent -O- Mat series RGX takes in air through the unobstructed large orifice when column separation occurs, but controls the discharge of air/gas through the "Anti-Surge" Orifice as the separated column commences to rejoin. The rejoining impact velocity is thereby sufficiently reduced to prevent an unacceptably high surge pressure in the system. In the same way the series RGX valve prevents high surge pressures resulting from liquid oscillation in a pipeline.

1. PIPELINE FILLING (SUB CRITICAL SEWAGE/ EFFLUENT APPROACH VELOCITY)

Air/gas flows through the annular area around the control float assembly and to atmosphere through the large orifice.

2. PIPELINE FILLING (EXCESSIVE SEWAGE/ EFFLUENT APPROACH VELOCITY)

In reaction to an increase in air/gas flow, the "Anti - Surge" float closes the large orifice and air/gas is forced through the "Anti - Surge" Orifice resulting in a deceleration of the approaching liquid due to the resistance of rising air/gas pressure in the valve.

Attention is drawn to Pre Notes (A) and (B) above.

3. PIPELINE FULLY CHARGED

Sewage/effluent has entered the valve chamber and buoyed the floats to close both the large and the small orifice. The design's compression/ volume relationship prevents the media from ever exceeding the maximum surge level indicated in diagram 3. The resultant sewage/ effluent free area protects against the fouling of the orifice seals by solids or high viscous substances - for this reason **NO FLUSHING CONNECTION ARE NECESSARY.**

4. PRESSURIZED AIR/ GAS RELEASE - PIPELINE OPERATING

The volume of disentrained air/gas increases in the valve and displaces the sewage/effluent to the lower, normal operating level (small orifice control float buoyancy level). Any additional lowering of the sewage/effluent level, as would occur when more air/gas enters the valve, will result in the control float dropping away from the small orifice through which pressurized air/gas is then being discharged to atmosphere.

The control float will close the small orifice when sufficient air/gas has been released to restore the sewage effluent to the normal operating level.

The considerable sewage/effluent free area obviates the possibility of leaks that could otherwise be caused by solids entering the sealing areas - for this reason **NO FLUSHING CONNECTIONS ARE NECESSARY.**

5. VACUUM RELIEF (AIR INTAKE) - PIPELINE DRAINING

When the internal pipeline pressure reduces to atmosphere the "Anti - Surge " mechanism and control float assembly drops, opens the large orifice and allows the pipeline to take in air to displace the draining media so as to prevent undesirable low negative pressure*. The hollow, smooth side float design discourages adherence of solids and viscous substances which, therefore, tend to withdraw from the valve into the pipeline when draining occurs - for this reason **NO FLUSHING CONNECTIONS ARE NECESSARY.**

***NOTE:** Negative pressure values are dependant on valve size selection.

RECOMMENDED INSTALLATION ARRANGEMENTS

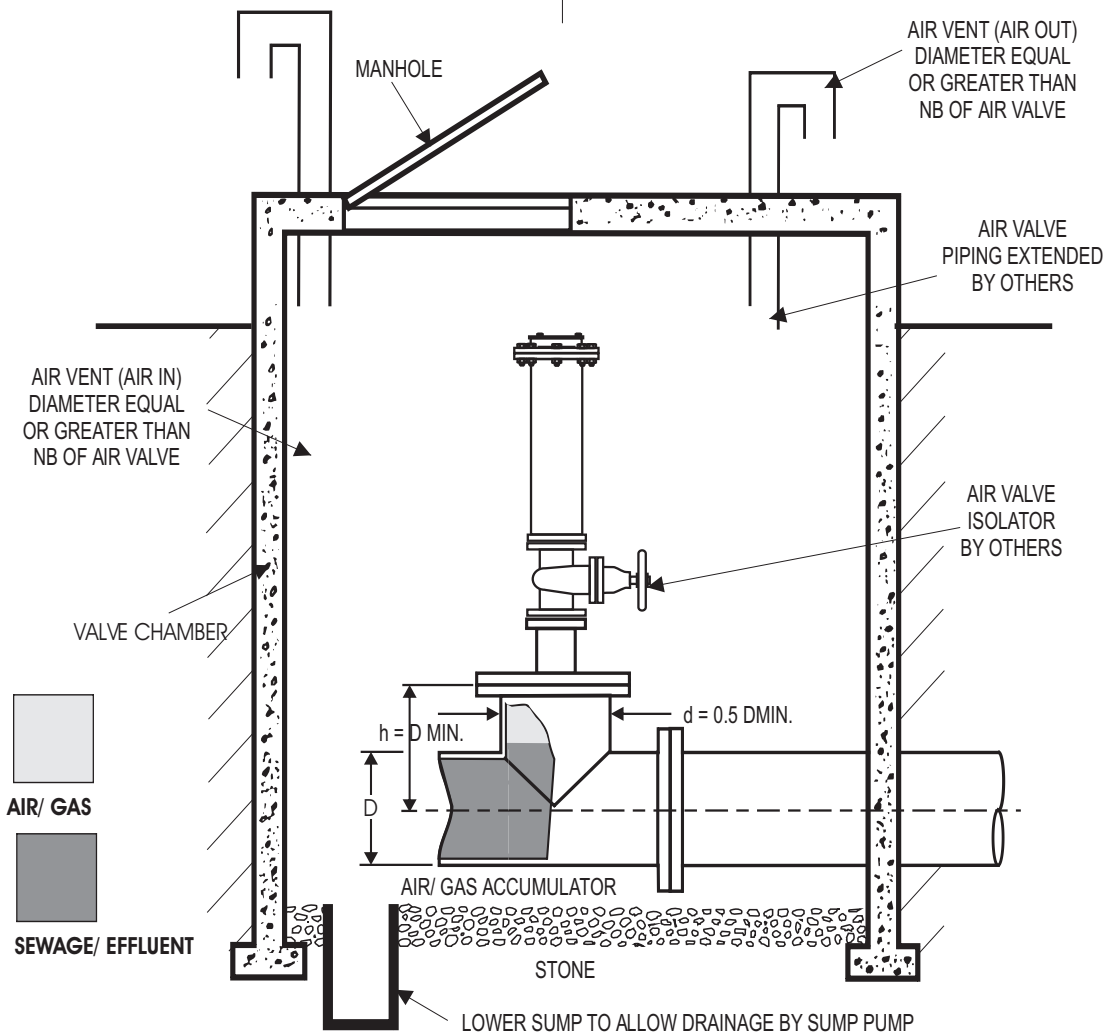
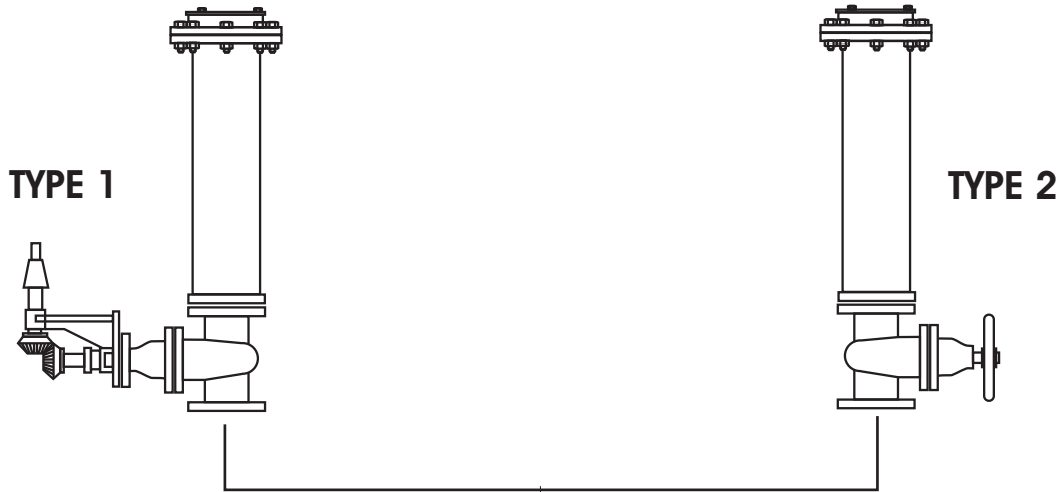

TYPICAL VALVE CHAMBER

AVAILABLE DISCHARGE CONNECTIONS

50 (2") TO 200 (8")

250 (10") & 300 (12") VALVES AVAILABLE ON REQUEST

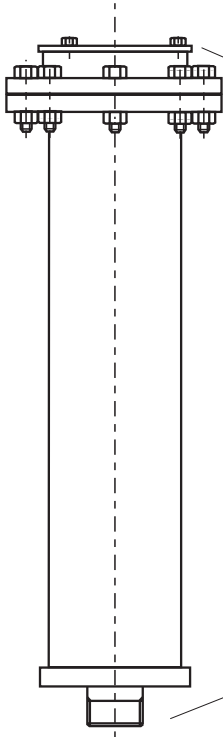

Standard Discharge Connection. Screen Mesh On Outlet.
DN50 (2"), DN80 (3"), DN100 (4"),
DN150 (6") & DN200 (8")

STANDARDS

Screwed BSP/NPT Inlet Connection.
DN50 (2") Valves Only.

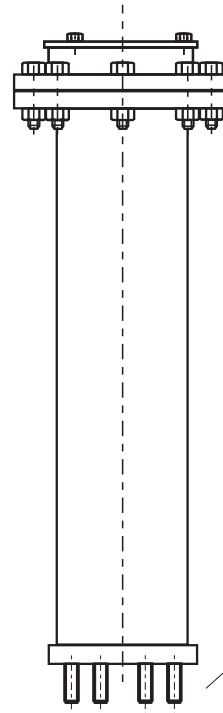

Studded Inlet Connection.
DN80 (3"), DN100 (4"),
DN150 (6") & DN200 (8")
Valves Only.

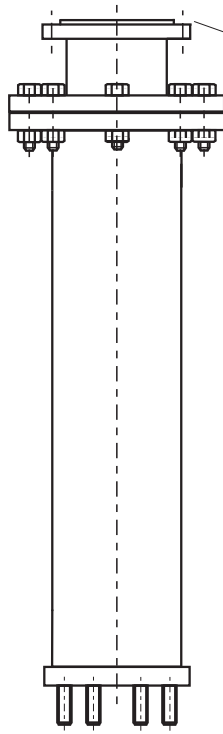

Swivel Flange Outlet Connection.*

SPECIAL ORDERS

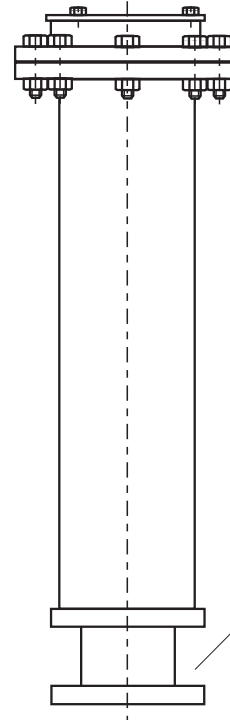

Flanged Trophy Inlet Connection for
DN250 (10") & DN300 (12")
Valves Only

***NOTE:**
Discharge Connections Are Equal To Valve Pressure Rating

COMPONENT DESCRIPTION & MATERIAL SPECIFICATION THREADED 50 (2") & STUDED INLET - 80 (3") TO 100 (4")

Type:

Series RGX - Double Orifice (Small & Large Orifice)
with "Anti-Surge" Mechanism.

End Connection:

Flange with Threaded BSP/NPT Male - 50 (2") valves.
Flange with Screwed Studs - 80 (3") & 100 (4") valves.

Nominal Sizes:

DN50 (2")
DN80 (3")
DN100 (4")

Model No:

RGX 1011/1021
RGX 1001/1031

Pressure Ratings:

PN10 (145 psi)
PN10 (145 psi)

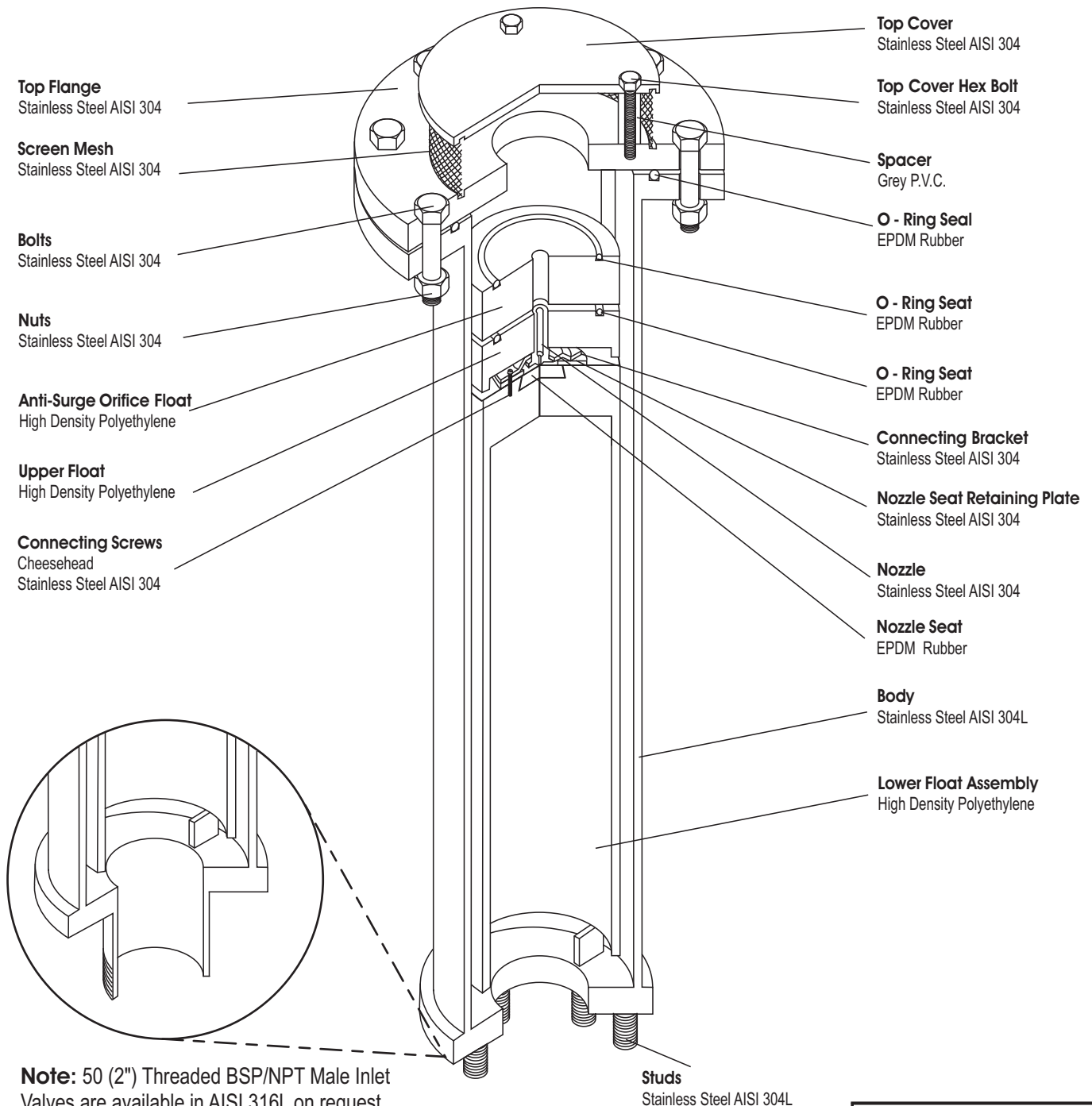

Note: 50 (2") Threaded BSP/NPT Male Inlet Valves are available in AISI 316L on request.

COMPONENT DESCRIPTION & MATERIAL SPECIFICATION THREADED 50 (2") & STUDED INLET - 80 (3") TO 100 (4") EXPANDED BODY

Type:
 Series RGX - Double Orifice (Small & Large Orifice)
 with "Anti-Surge" Mechanism.

End Connection:
 Flange with Threaded BSP/NPT Male 50 (2") valves.
 Flange with Screwed Studs 80 (3") & 100 (4") valves.

Nominal Sizes:
 DN50 (2")
 Dn80 (3")
 DN100 (4")

Model No's:
 RGX 1611/1621 _____ PN16 (232 psi)
 RGX 1601/1631 _____ PN16 (232 psi)

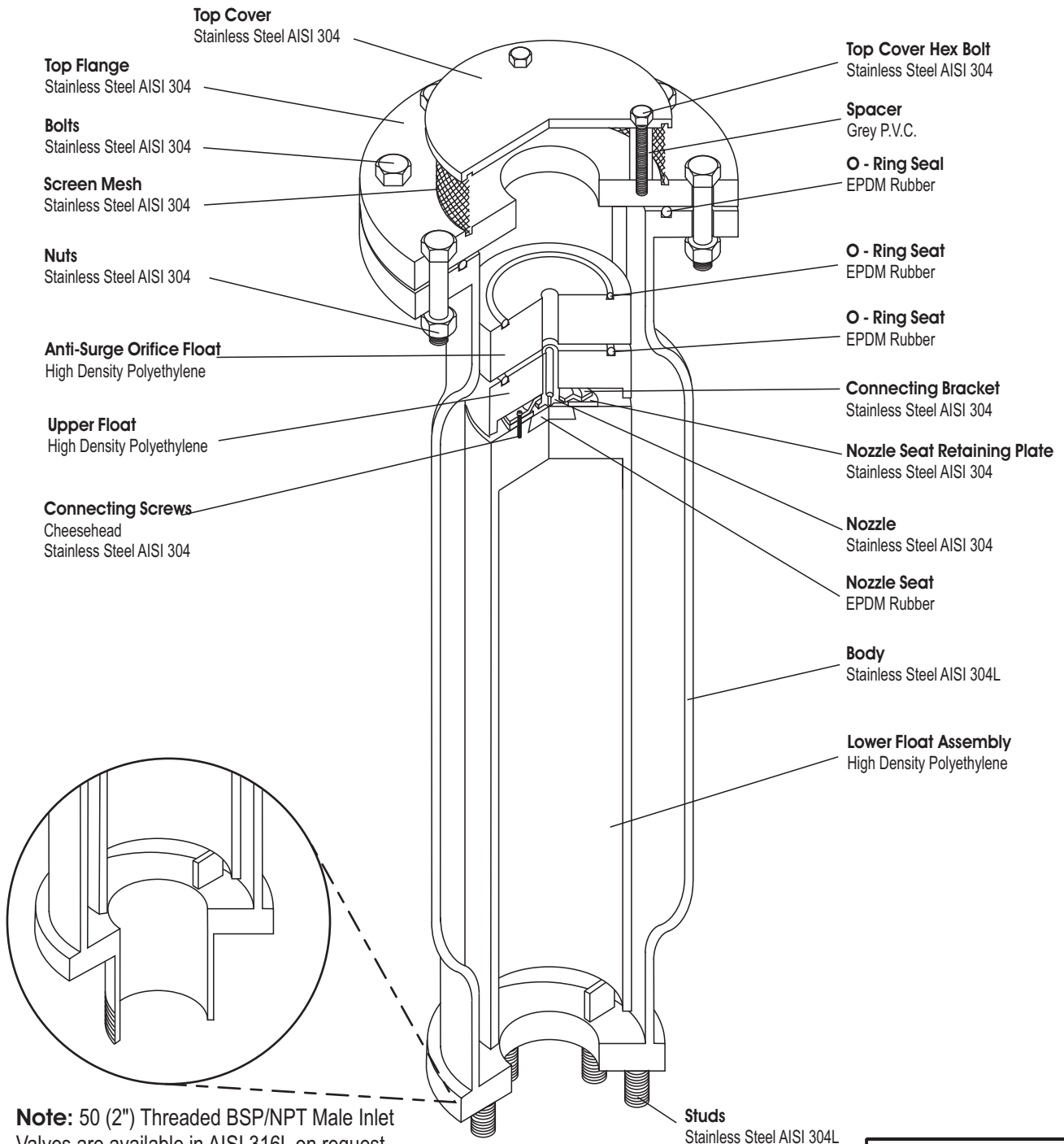

Note: 50 (2") Threaded BSP/NPT Male Inlet Valves are available in AISI 316L on request.

COMPONENT DESCRIPTION & MATERIAL SPECIFICATION
STUDED INLET - 150 (6") & 200 (8")

Type:
 Series RGX - Double Orifice (Small & Large Orifice)
 with "Anti-Surge" Mechanism.

End Connection:
 Flange with Screwed Studs - 150 (6") & 200 (8") valves.

Nominal Size:
 DN150 (6")
 DN200 (8")

Model No:
 RGX 1001/1031

Pressure Rating:
 PN10 (145 psi)

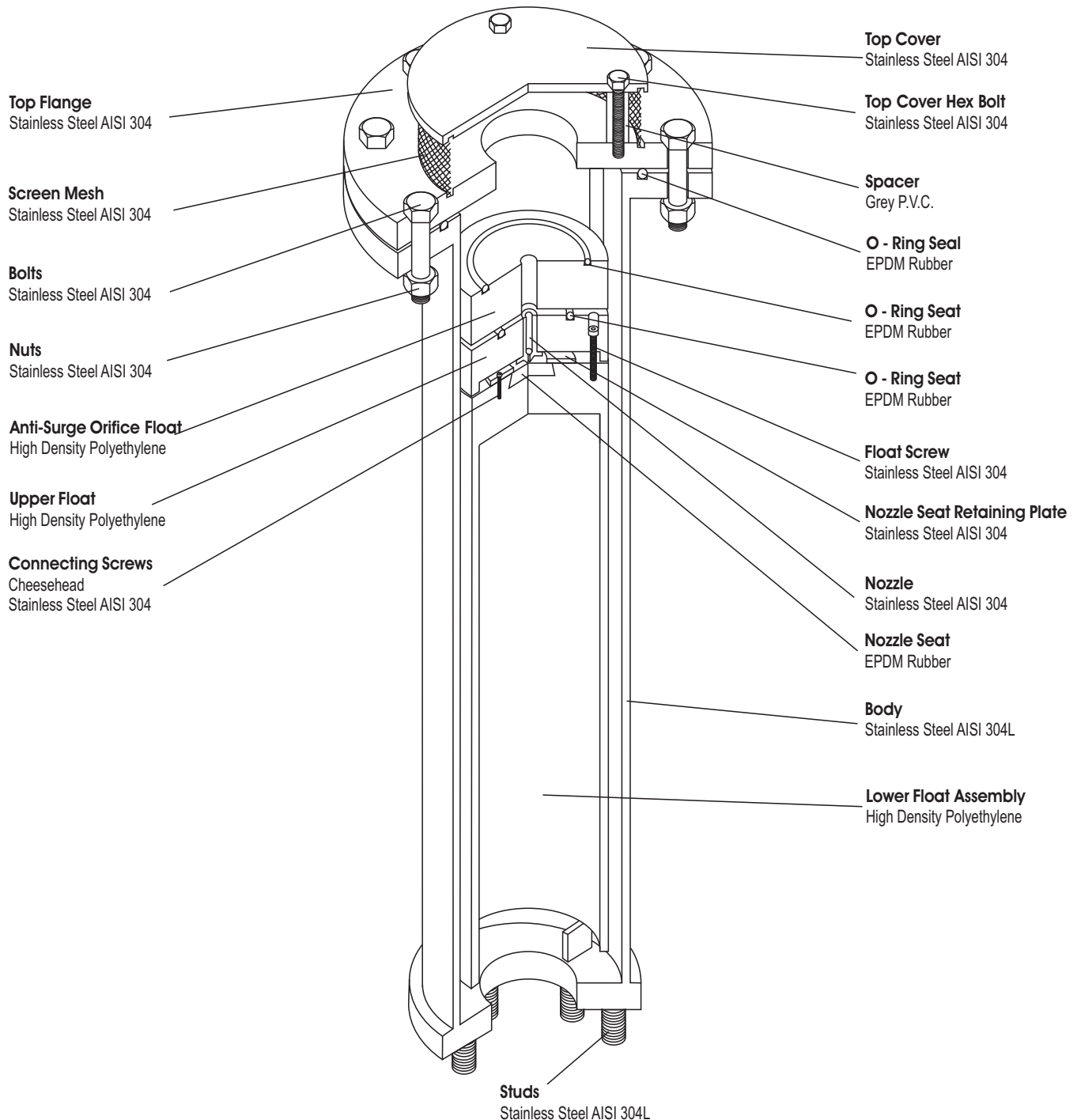

Note: Valves are available in AISI 316L on request.

information subject to change without prior notice

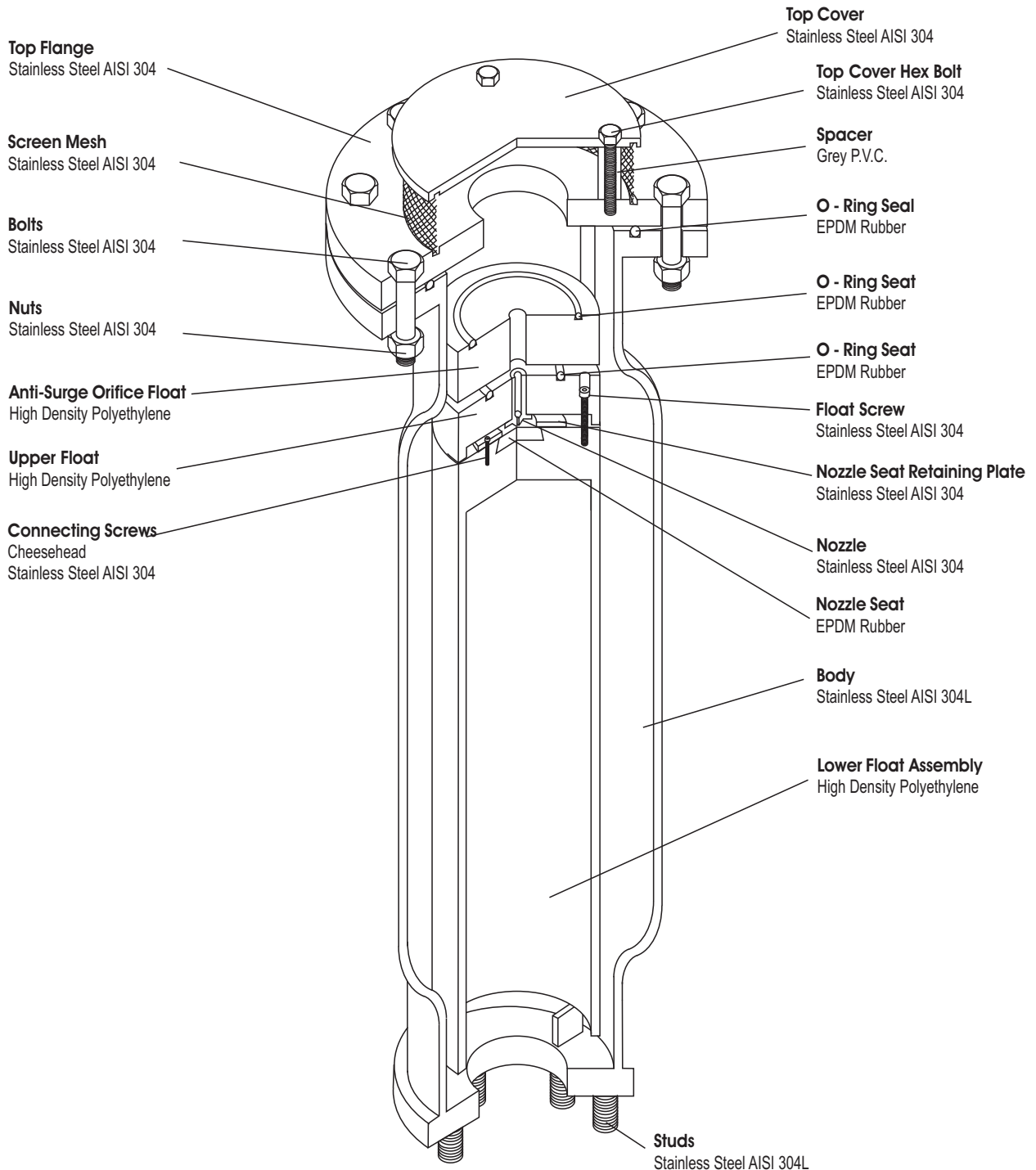
COMPONENT DESCRIPTION & MATERIAL SPECIFICATION
STUDED INLET - 150 (6") & 200 (8") EXPANDED BODY**Type:**
Series RGX - Double Orifice (Small & Large Orifice)
with "Anti-Surge" Mechanism.**End Connection:**
Flange with Screwed Studs - 150 (6") & 200 (8") valves.**Nominal Sizes:**
150 (6")
200 (8")**Model No's:**
RGX 1601/1631 _____**Pressure Ratings:**
PN16 (232 psi)**Note:** Valves are available in AISI 316L on request.

information subject to change without prior notice

GENERAL SPECIFICATIONS

THREADED 50 (2") & STUDED INLET - 80 (3") TO 200 (8")

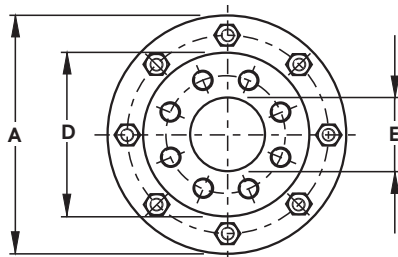
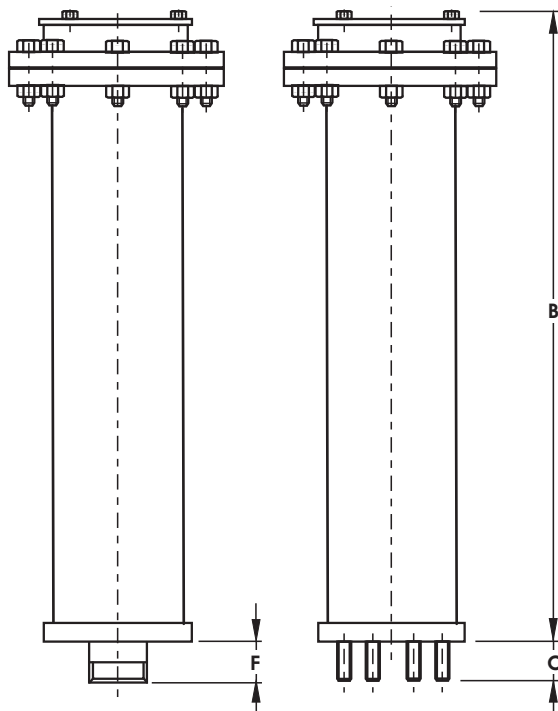
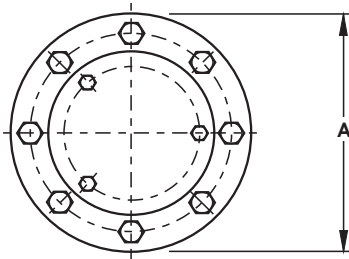

Type:

Double Orifice (Small & Large Orifice) with Anti Surge Orifice mechanism.

End Connection:

Flange with DN50 (2") Male BSP/NPT Threaded and Screwed Studs for Alignment to BS4504, SABS 1123 and ANSI B16.5 Class 150 for DN80 (3") to DN200 (8").

Nominal Sizes:

DN50 (2"), DN80 (3"), DN100 (4"), DN150 (6") & DN200 (8")

Model No's:

RGX 1011/1021 _____
 RGX 1001/1031 _____

Pressure Ratings bar (psi):

PN10 (145 psi)
 PN10 (145 psi)

Operating Pressure Range - bar (psi):

		Min	Max.
PN10 (145 psi)	_____	0.5 (7.2)	10 (145)

Function:

- i) High volume air/gas discharge - pipeline filling.
- ii) High volume air intake - pipeline draining
- iii) Pressurized air/gas discharge - pipeline filled.
- iv) Surge dampening - high velocity air/gas discharge, liquid column separation & liquid oscillation.

Valve Selection:- see pages 11 & 12

Materials of Construction:- see pages 5 & 7

Installation:- see page 3

Standard Factory Tests:

- i) Hydrostatic test -1.5 x max. rated working pressure
- ii) Low head leak test - 0.5 bar (7.2 psi)
- iii) Small orifice function test at max. rated working pressure (minimum 1 valve in 10).

OVERALL DIMENSIONS & WEIGHTS

DN		Model No.	A		B		C		D		E		F		Weight	
mm	in		mm	in	mm	in	mm	in	mm	in	mm	in	mm	in	kg	lbs
50	2	050 RGX 1011/1021	220	8 2/3	770	30 3/8	N/A		125	5	50	2	42	1 2/3	18	39.7
80	3	080 RGX 1001/1031	285	11 1/4	780	30 7/10	55	2 1/8	200	7 7/8	80	3	N/A		36.5	80.5
100	4	100 RGX 1001/1031	285	11 1/4	780	30 7/10	55	2 1/8	220	8 2/3	100	4	N/A		36	79.4
150	6	150 RGX 1001/1031	395	15 9/16	1060	41 7/10	55	2 1/8	285	11	150	6	N/A		82	180.8
200	8	200 RGX 1001/1031	445	17 1/2	1060	41 7/10	55	2 1/8	340	13 9/16	200	8	N/A		103	227

Note: DN50 (2") valves have DN50 (2") BSP/NPT male inlet connections as standard. information subject to change without prior notice

GENERAL SPECIFICATIONS

THREADED 50 (2") & FLANGED - 50 (2") TO 200 (8") EXPANDED BODY

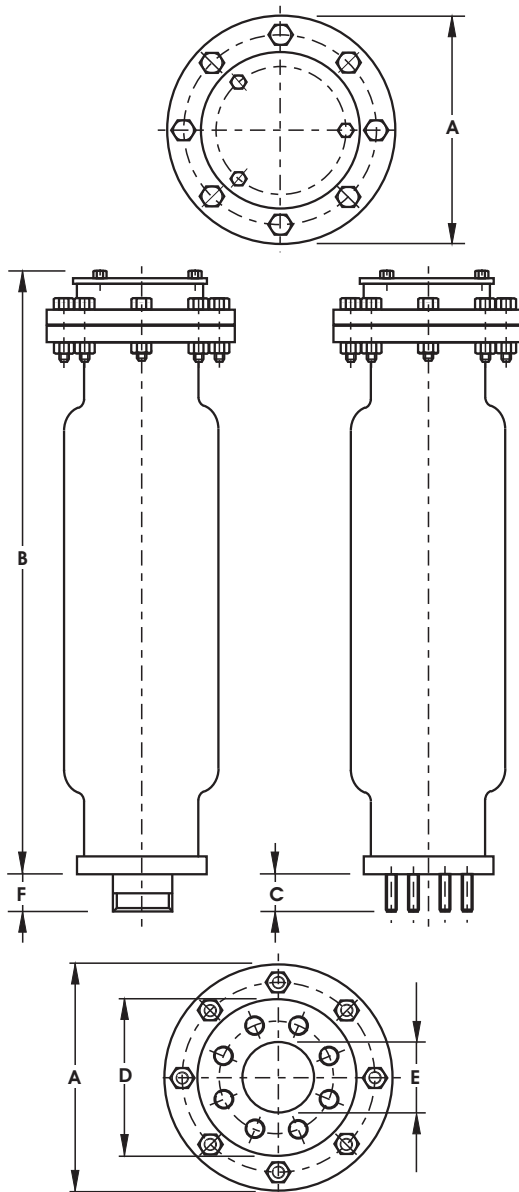

Type:

Double Orifice (Small & Large Orifice) with Anti Surge Orifice mechanism.

End Connection:

Flange with DN50 (2") Male BSP/NPT Threaded and Screwed Studs for Alignment to BS4504, SABS1123 and ANSI B16.1 Class 150 for DN80 (3") to DN200 (8").

Nominal Sizes:

DN50 (2"), DN80 (3"), DN100 (4"), DN150 (6") & DN200 (8")

Model No's:

RGX 16Y1 _____

Pressure Ratings bar (psi):

PN16 (232 psi) ANSI #125

Operating Pressure Range - bar (psi):

	Min	Max.
PN16 (232 psi) ANSI #125	0.5 (7.2)	16 (232)

Function:

- i) High volume air/gas discharge - pipeline filling.
- ii) High volume air intake - pipeline draining
- iii) Pressurized air/gas discharge - pipeline filled.
- iv) Surge dampening - high velocity air/gas discharge, liquid column separation & liquid oscillation.

Valve Selection:- see pages 11 & 12

Materials of Construction:- see pages 6 & 8

Installation:- see page 3

Standard Factory Tests:

- i) Hydrostatic test -1.5 x max. rated working pressure
- ii) Low head leak test - 0.5 bar (7.2 psi)
- iii) Small orifice function test at max. rated working pressure (minimum 1 valve in 10).

OVERALL DIMENSIONS & WEIGHTS

DN		Model No.	A		B		C		D		E		F		Weight	
mm	in		mm	in	mm	in	mm	in	mm	in	mm	in	mm	in	kg	lbs
50	2	050 RGX 1611 & 1621	220	8 2/3	770	30 3/8	N/A		125	5	50	2	42	1 2/3	21	46.3
80	3	080 RGX 1601 & 1631	285	11 1/4	780	30 7/10	55	2 1/8	200	7 7/8	80	3	N/A		37.5	82.67
100	4	100 RGX 1601 & 1631	285	11 1/4	780	30 7/10	55	2 1/8	220	8 2/3	100	4	N/A		37	81.57
150	6	150 RGX 1601 & 1631	395	15 9/16	1060	41 7/10	55	2 1/8	285	11	150	6	N/A		84.5	186.3
200	8	200 RGX 1601 & 1631	445	17 1/2	1060	41 7/10	55	2 1/8	340	13 6/16	200	8	N/A		105.5	232.6

Note: DN50 (2") valves have DN50 (2") BSP/NPT male inlet connections as standard.
information subject to change without prior notice

SELECTION & POSITIONING

Conversion Table: - l/min. to m/sec. of Pipeline Velocity

Pipe Dia mm	Pipeline Velocity in Metres per sec																			
	0.5	1	1.5	2	2.5	3	3.5	4	4.5	5	5.5	6	6.5	7	7.5	8	8.5	9	9.5	10
100	4	8	12	16	20	24	27	31	35	39	43	47	51	55	59	63	67	71	75	79
150	9	18	27	35	44	53	62	71	80	88	97	106	115	124	133	141	150	159	168	177
200	16	31	47	63	79	94	110	126	141	157	173	188	204	220	236	251	267	283	298	314
250	25	49	74	98	123	147	172	196	221	245	270	295	319	344	368	393	417	442	466	491
300	35	71	106	141	177	212	247	283	318	353	389	424	459	495	530	565	601	636	672	707
350	48	96	144	192	241	289	337	385	433	481	529	577	625	673	722	770	818	866	914	962
400	63	126	188	251	314	377	440	503	565	628	691	754	817	880	942	1005	1068	1131	1194	1257
450	80	159	239	318	398	477	557	636	716	795	875	954	1034	1113	1193	1272	1352	1431	1511	1590
500	98	196	295	393	491	589	687	785	884	982	1080	1178	1276	1374	1473	1571	1669	1767	1865	1963
550	119	238	356	475	594	713	832	950	1069	1188	1307	1425	1544	1663	1782	1901	2019	2138	2257	2376
600	141	283	424	565	707	848	990	1131	1272	1414	1555	1696	1838	1979	2121	2262	2403	2545	2686	2827
650	166	332	498	664	830	995	1161	1327	1493	1659	1825	1991	2157	2323	2489	2655	2821	2986	3152	3318
700	192	385	577	770	962	1155	1347	1539	1732	1924	2117	2309	2501	2694	2886	3079	3271	3464	3656	3848
750	221	442	663	884	1104	1325	1546	1767	1988	2209	2430	2651	2872	3093	3313	3534	3755	3976	4197	4418
800	251	503	754	1005	1257	1508	1759	2011	2262	2513	2765	3016	3267	3519	3770	4021	4273	4524	4775	5027
850	284	567	851	1135	1419	1702	1986	2270	2554	2837	3121	3405	3688	3972	4256	4540	4823	5107	5391	5675
900	318	636	954	1272	1590	1909	2227	2545	2863	3181	3499	3817	4135	4453	4771	5089	5407	5726	6044	6362
950	354	709	1063	1418	1772	2126	2481	2835	3190	3544	3899	4253	4607	4962	5316	5671	6025	6379	6734	7088
1000	393	785	1178	1571	1963	2356	2749	3142	3534	3927	4320	4712	5105	5498	5890	6283	6676	7069	7461	7854
1100	475	950	1425	1901	2376	2851	3326	3801	4276	4752	5227	5702	6177	6652	7127	7603	8078	8553	9028	9503
1200	565	1131	1696	2262	2827	3393	3958	4524	5089	5655	6220	6786	7351	7917	8482	9048	9613	10179	10744	11310
1300	664	1327	1991	2655	3318	3982	4646	5309	5973	6637	7300	7964	8628	9291	9955	10619	11282	11946	12610	13273
1400	770	1539	2309	3079	3848	4618	5388	6158	6927	7697	8467	9236	10006	10776	11545	12315	13085	13854	14624	15394
1500	884	1767	2651	3534	4418	5301	6185	7069	7952	8836	9719	10603	11486	12370	13254	14137	15021	15904	16788	17671
1600	1005	2011	3016	4021	5027	6032	7037	8042	9048	10053	11058	12064	13069	14074	15080	16085	17090	18096	19101	20106
1700	1135	2270	3405	4540	5675	6809	7944	9079	10214	11349	12484	13619	14754	15889	17024	18158	19293	20428	21563	22698
1800	1272	2545	3817	5089	6362	7634	8906	10179	11451	12723	13996	15268	16540	17813	19085	20358	21630	22902	24175	25447
1900	1418	2835	4253	5671	7088	8506	9924	11341	12759	14176	15594	17012	18429	19847	21265	22682	24100	25518	26935	28353
2000	1571	3142	4712	6283	7854	9425	10996	12566	14137	15708	17279	18850	20420	21991	23562	25133	26704	28274	29845	31416
2100	1732	3464	5195	6927	8659	10391	12123	13854	15586	17318	19050	20782	22513	24245	25977	27709	29441	31172	32904	34636
2200	1901	3801	5702	7603	9503	11404	13305	15205	17106	19007	20907	22808	24709	26609	28510	30411	32311	34212	36113	38013
2300	2077	4155	6232	8310	10387	12464	14542	16619	18696	20774	22851	24929	27006	29083	31161	33238	35315	37393	39470	41548
2400	2262	4524	6786	9048	11310	13572	15834	18096	20358	22619	24881	27143	29405	31667	33929	36191	38453	40715	42977	45239
2500	2454	4909	7363	9817	12272	14726	17181	19635	22089	24544	26998	29452	31907	34361	36816	39270	41724	44179	46633	49087
2600	2655	5309	7964	10619	13273	15928	18583	21237	23892	26546	29201	31856	34510	37165	39820	42474	45129	47784	50438	53093
2700	2863	5726	8588	11451	14314	17177	20039	22902	25765	28628	31491	34353	37216	40079	42942	45804	48667	51530	54393	57256
2800	3079	6158	9236	12315	15394	18473	21551	24630	27709	30788	33866	36945	40024	43103	46181	49260	52339	55418	58496	61575
2900	3303	6605	9908	13210	16513	19816	23118	26421	29723	33026	36329	39631	42934	46236	49539	52842	56144	59447	62749	66052
3000	3534	7069	10603	14137	17671	21206	24740	28274	31809	35343	38877	42412	45946	49480	53014	56549	60083	63617	67152	70686

VALVE SELECTION GRAPH

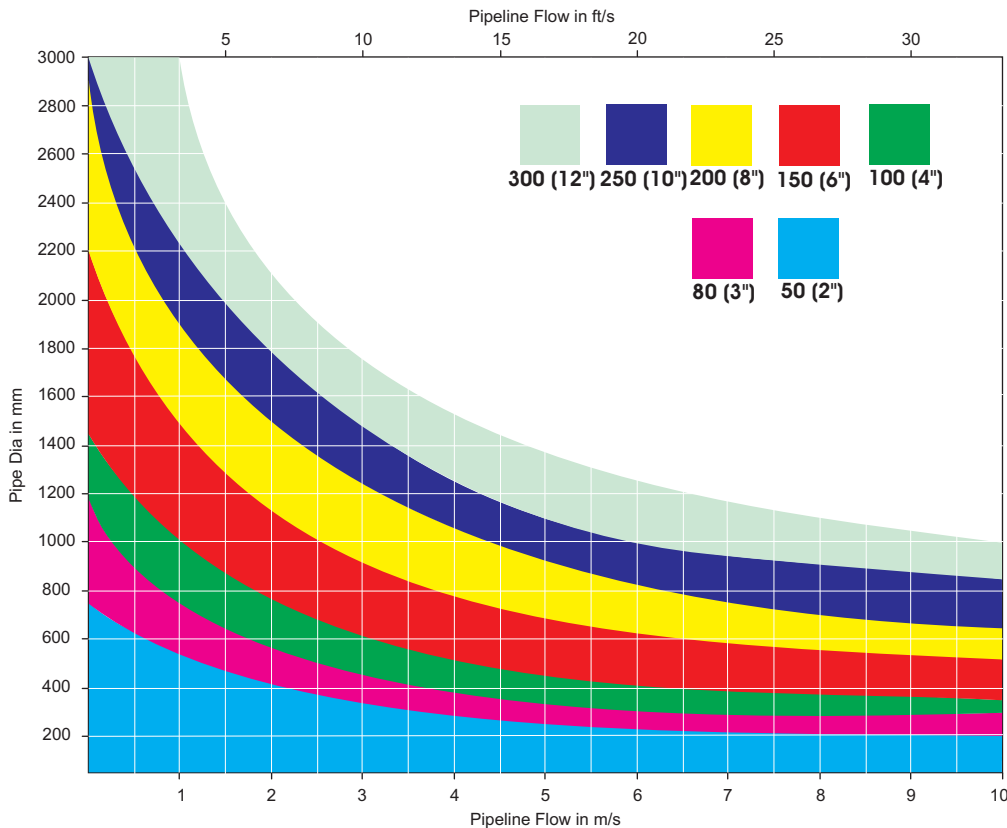

SELECTION & POSITIONING

VALVE SELECTION FROM GRAPH

All the relevant information has been condensed into one graph to enable valve selection to be simple and easy and at the same time to allow flexibility to the designer to move within certain parameters which eventually allows the most suited and economically viable valve to be selected.

IMPORTANT NOTE: The graph is based on vacuum breaking and limiting vacuum to 0.34 bar (5 psi) below atmospheric. It is not good practice to go below 0.69 bar (10 psi) absolute (0.303bar (4.4 psi) differential in pipeline at sea level). The graph allows for change in altitude and hence change in atmospheric pressure and is based on the assumption that more than one valve per section is used for vacuum protection and venting

ACTUAL SELECTION (GRAVITY OR PUMPED PIPELINES)

Selection is based on the premise that pipelines are generally filled at a slower rate than they are drained, scoured or at which separation occurs (a maximum fill/ drain ratio of 1:1).

1. Determine the maximum drainage rate in m/s either for scouring, pipe rupture or column separation for a particular pipeline section.
2. Move vertically on the graph from the m/s point and move horizontally from the pipe size finding the intersecting point.
3. This point should fall within the operating band of a particular valve size. Consideration must be given to the fact that the upper portion of the band approaches - 0.34 bar (5 psi) and the lower portion - 0.1 bar (1.45 psi) for each valve size, this allows the designer to see at a glance if the valve is too close to it's operating limits and to select the next valve size.

EXAMPLE OF VALVE SIZING (ASSUMING AN INDIVIDUAL SECTION)

A \varnothing 400mm (16") pipeline draining at 377l/sec which equates to 3m/sec (10ft/s) what valve size should be selected?

From the 3m/sec (10ft/s) point, move vertically until the \varnothing 400mm (16") pipe size horizontal line is intersected. This places the intersection point squarely in the centre of the operating band of a DN80 (3") Vent -O- Mat RGX valve. But, if for example, the drainage rate is 503l/sec which equates to 4m/sec (13.2ft/s), the valve would be operating on it's limit and it may be prudent to change to a DN100 (4") Vent-O-Mat RGX.

VALVE POSITIONING

1. ON APEX POINTS (relative to hydraulic gradient).
2. 5 METERS (16 FEET) BELOW APEX POINTS FORMED BY INTERSECTION OF PIPELINE AND HYDRAULIC GRADIENT - i.e. where pipeline siphoning over Gradient a sewage air release valve positioned on the apex would break the siphon. If positioning on apex is required a modified VENT -O- MAT Series RGX can be supplied.
3. NEGATIVE BREAKS (increase in downward slope or decrease in upward slope).
4. LONG HORIZONTAL SECTIONS - every 600 meters (1/3 of a mile) maximum.
5. LONG ASCENDING SECTIONS - every 600 meters (1/3 of a mile) maximum.
6. LONG DESCENDING SECTIONS - every 600 meters (1/3 of a mile) maximum.
7. PUMP DISCHARGE (not shown in diagram) - just subsequent to non return valve.
8. BLANK ENDS (not shown in diagram) - where a pipeline is terminated by a blind flange or a valve.

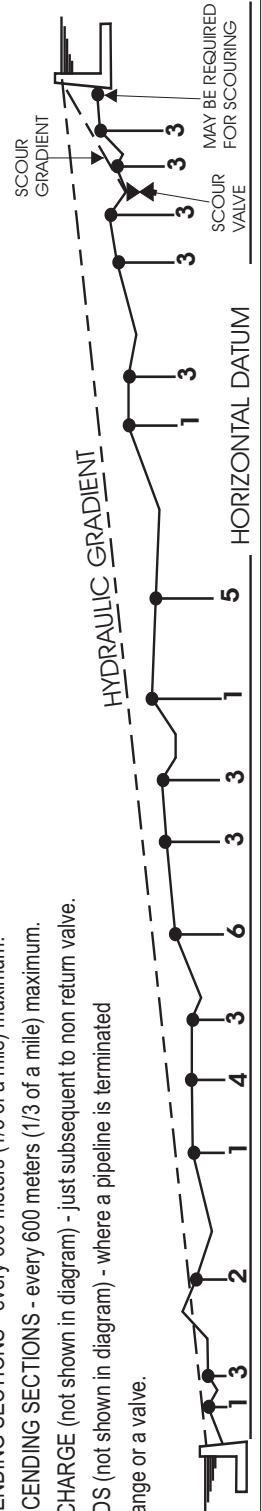

SURGE & WATERHAMMER PROTECTION

Introduction

The Vent-O-Mat Series RGX "Anti-Surge" sewage air release and vacuum break valve, is the product of extensive research into the development of an efficient, but cost effective solution to surge problems (both mass liquid oscillation and elastic transient phenomena) associated with any operating pipeline. Automatic dampening, relevant to the pipeline's needs is provided by either one of three design features. These special features are unique in a pipeline component of such compact and economic design.

Surge Protection - Initial Filling

The RGX incorporates the additional floating "Anti-Surge" Orifice which is aerodynamically engineered to throttle air discharge when liquid approach velocity would otherwise become too great and induce an unacceptable pressure rise. The air throttling action increases resistance to the flow of the approaching liquid which consequently decelerates to a velocity which reduces the pressure rise when the valve closes (see operation of valve on pages 1 & 2). Vent-O-Mat series RGX is an essential precaution for pipeline priming.

Surge Protection - Pump Trip Conditions

In instances where a pipeline experiences liquid column separation due to pump stoppage, high shock pressures can be generated when the separated liquid column rejoins.

The Vent-O-Mat series RGX takes in air through the unobstructed large orifice when liquid column separation occurs, but controls the discharge of air/gas through the "Anti-Surge" Orifice as the separated column commences to rejoin. The rejoining impact velocity is thereby considerably reduced to alleviate high surge pressures in the system (see operation of valve on pages 1 & 2).

Other surge control measures may, dependant on pipeline profile, diameter and operating conditions, be needed to provide the primary surge alleviation function with the Vent-O-Mat sewage air-valves forming an integral and valuable addition in a combined strategy for further reducing surge pressures. The benefit of the "Anti-Surge" Orifice can be readily demonstrated by suitable surge modelling software.

Surge Protection - Pipeline Operating

The operation of valves and similar flow control devices can cause high-pressure transients in an operating pipeline.

The unique, single chamber design of the Vent-O-Mat series RGX valve enables a pocket of air to be trapped in the valve chamber. Automatic operation of the small orifice control float regulates the volume of air entrapped.

The volume maintained in the valve will provide a cushioning benefit to the pipeline for short duration transient pressure "spikes". This effect can be modelled by the design engineer using suitable surge software.

SURGE & WATERHAMMER PROTECTION

Computer Modelling

The effectiveness of Vent-O-Mat series RGX has been substantiated by independent third party testing and by thousands of applications globally. Effective computer modelling, based on practical tests, has been ensured in the well-known and respected commercially available surge analysis software programmes such as AFT impulse, FLOWMASTER, TRANSAM and SURGE 2000.

Holistic Surge & Water Hammer Protection

Vent-O-Mat forms an integral part of a well planned, holistic surge protection strategy that should, according to application needs and financial constraints, include surge vessels, check valves, control valves and/or any other equipment needed to alleviate unacceptable surge behaviour.

Technical and Financial Benefits

The Vent-O-Mat series RGX valve offers definite financial and technical advantages when incorporated as part of a holistic surge protection strategy. This includes:

1. Improved alleviation of surge behaviour including reduction of:
 - Surge pressure magnitudes by slowing surge velocities
 - Duration of oscillation following a pump trip, as the sewage air-valve continuously absorbs and dissipates the energies of the surge.
2. Potential for reduction in size and/or quantity of conventional surge protection devices such as surge vessels etc.
3. Automatic protection during initial filling when most surge protection devices are not operational.
4. Holistic protection as each sewage air valve installed has design features to automatically damp surges.
5. The valve is virtually maintenance free.

Service

Vent-O-Mat is committed to finding the most cost effective and efficient solution to pipeline complexities. Services include air valve sizing and positioning and assistance to consulting engineers on defining appropriate surge and water hammer protection strategies. Vent-O-Mat has built a sound relationship with many international consulting firms and has gained global recognition for selling solutions!

SMALL ORIFICE DISCHARGE PERFORMANCE

Type:

Series RGX - Double Orifice (Small & Large Orifice)
with "Anti-Surge" Orifice Mechanism

Model No's:

RGX 1001/1011/1021/1031
RGX 1601/1611/1621/1631
RGX 2501/2511/2521/2531

- █ 2mm (0.07") small orifice - DN50 (2"), DN80 (3"), Dn100 (4") Valves
- █ 5mm (0.20") small orifice - DN150 (6") Valves
- █ 6mm (0.24") small orifice - DN200 (8") Valves

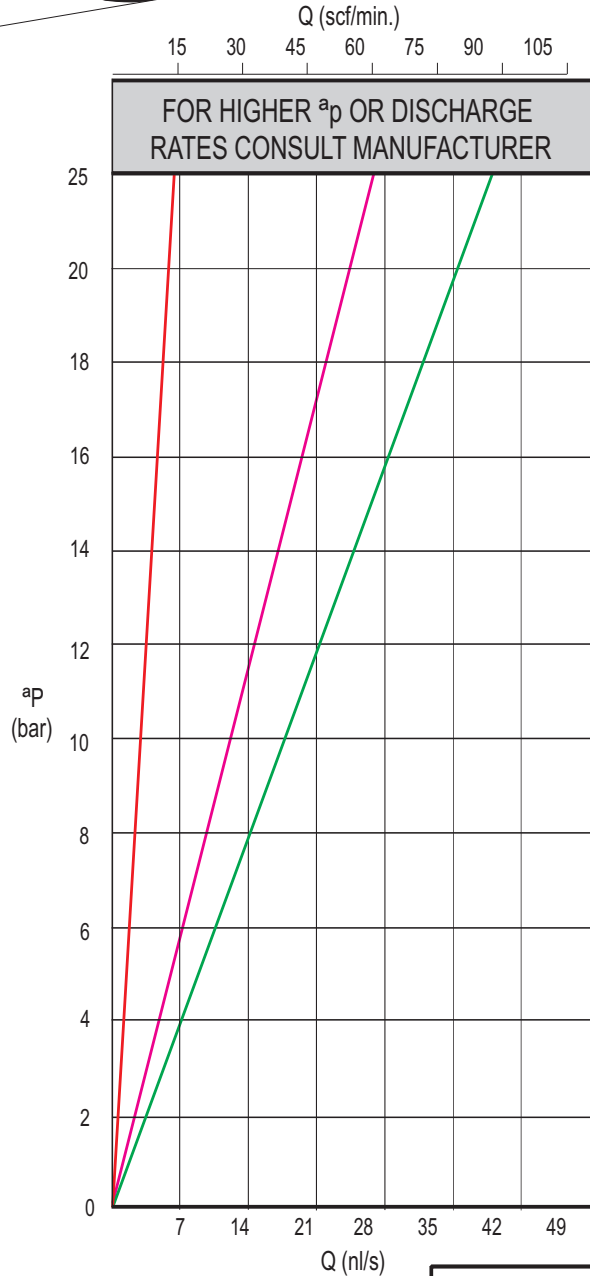
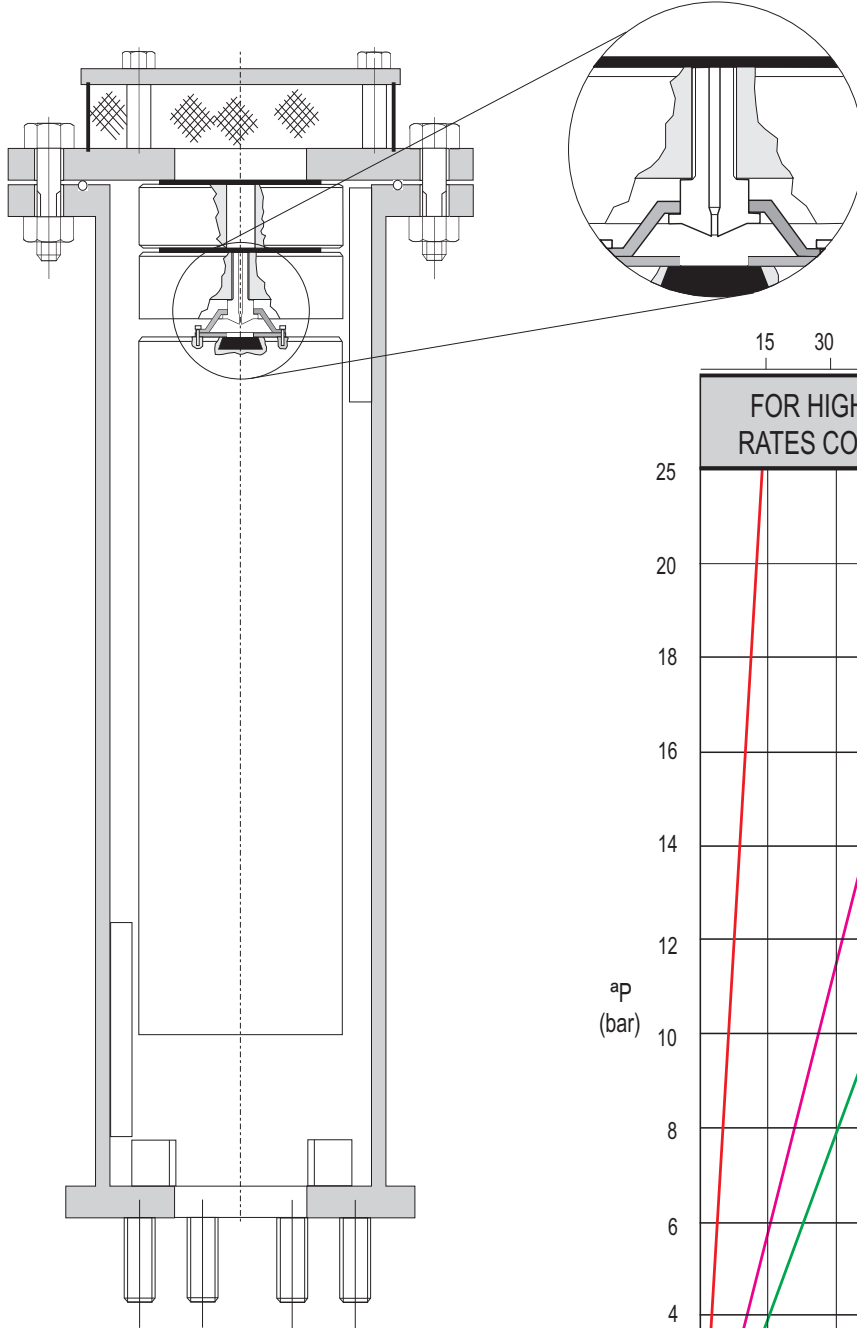

Q = Normal Litres per second (Free Air) @ 1.01325 bar Abs. and 20 deg. C	Q _v = Standard Cubic Feet per minute (Free Air) @ 14.7 psi Abs. 68 deg. F
CONVERSION EQUIVALENTS	
1 l / sec. = 2.1189 scf / min.	1 scf / min = 0.472 l / sec.
1 bar = 14.5 psi	1 psi = 0.069 bar

Why?

- **"ANTI - SHOCK" - "ANTI - SURGE"** - The RGX is the only air release valve available that is supplied as standard with a mechanism which operates automatically to prevent pipeline damage from the high induced pressure transients associated with high velocity air discharge. Surge resulting from liquid column separation and liquid oscillation is dramatically reduced as an automatic function of this mechanism.
- **PERFORMANCE** - The RGX has been designed and developed to provide the optimum usable and safe performance relative to all functions. Selection data has been substantiated through CSIR* and other testing and can therefore, be confidently referenced.
- **QUALITY** - The RGX economically offers the highest quality construction and materials available in an air release and vacuum break valve. Stringent manufacturing and test procedures are maintained to ensure the best possible service and reliability is given by every valve produced.
- **SERVICEABILITY** - The RGX design facilitates extreme ease of service and maintenance. Components are in corrosion free materials to allow problem free disassembly and reassembly even after many years of operation. All maintenance spares are replaceable without special tools or skills.
- **VACUUM BREAK** - The RGX series large orifice diameters equal the nominal size of the valve, i.e., a 200mm (8") valve has a 200mm (8") orifice. This ensures the least possible resistance to the intake of air and consequently the least possible negative pressure within a draining pipeline.
- **COMPACTNESS** - Although extremely robust the RGX valve's lightweight and compact construction offers handling transport and installation advantages.
- **BACK UP** - Vent -O- Mat provides highly committed customer orientated sales, service, spares and technical back up - TRY US!!!

* Council for Scientific and Industrial Research

PURCHASE SPECIFICATION**VENT -O- MAT MODEL NO.**

Page 9 - Series RGX - DN50 (2") to DN200 (8").

Page 10 - Series RGX - DN50 (2") to DN200 (8"). (Expanded Body)

CONSTRUCTION & DESIGN

The Sewage Air Release & Vacuum Break Valve shall consist of a compact tubular all stainless steel fabricated body, hollow direct acting float and solid large orifice float in H.D.P.E. - stainless steel nozzle and woven dirt inhibitor screen, EPDM rubber seals and seat.

The valve shall have an integral "Anti-Surge" Orifice mechanism which shall operate automatically to limit transient pressure rise or shock induced by closure to less than 1.5 x valve rated working pressure.

The intake orifice area shall be equal to the nominal size of the valve i.e., a 150mm (6") valve shall have a 150mm (6") intake orifice. Large orifice sealing shall be effected by the flat face of the control float seating against a EPDM rubber 'O' ring housed in a dovetail groove circumferentially surrounding the orifice.

Discharge of pressurized air shall be controlled by the seating & unseating of a small orifice nozzle on a natural rubber seal affixed into the control float. The nozzle shall have a flat seating land surrounding the orifice so that damage to the rubber seal is prevented.

The valve construction shall be proportioned with regard to material strength characteristics, so that deformation, leaking or damage of any kind does not occur by submission to twice the designed working pressure.

Connection to the valve inlet shall be facilitated by flanged ends conforming to PN10, 16 or 25 ratings of BS4504 or SABS 1123 Standards or ANSI B16.1 Class 125 & Class 250 and ANSI B16.5 Class 150 or Class 300 Standards. AS 4087 Fig. B7 - B9, AS 2129 Table E/F. Flanged ends shall be supplied with the requisite number of stainless steel screwed studs inserted for alignment to the specified standard. **Nuts and washers shall be excluded.**

OPERATION

1. Prior to the ingress of liquid into the valve chamber, as when the pipeline is being filled, valves shall vent through the large orifice when sewage/effluent approach velocities are relative to a transient pressure rise, on valve closure, of $< 1.5 \times$ valve rated pressure.
At higher sewage/effluent approach velocities, which have a potential to induce transient pressure rises $> 1.5 \times$ valve rated pressure on valve closure, the valve shall automatically discharge air/gas through the "Anti-Surge" Orifice and reduce sewage/effluent approach velocity, so that on closure a maximum Transient pressure rise of $< 1.5 \times$ valve rated pressure is realised.
2. Valves shall not exhibit leaks or weeping of liquid past the large orifice seal at operating pressures of 0,5 bar (7.2 psi) to $1.5 \times$ valve rated working pressure.
3. Valves shall respond to the presence of air/gas by discharging it through the small orifice at any pressures within a specified design range, i.e. 0,5 bar (7.2 psi) to 10 bar (145 psi) and shall remain leak tight in the absence of air.
4. Valves shall react immediately to pipeline drainage or liquid column separation by the full opening of the large orifice so as to allow unobstructed air intake at the lowest possible negative internal pipeline pressure.

ORDERING GUIDE**VALVE SIZE:**

DN50 (2") -
 DN80 (3") -
 DN100 (4") -
 DN150 (6") -
 DN200 (8") -

VALVE SERIES No.**ANTI-SURGE ORIFICE:****050 RG X 10 1 1****VALVE TYPE:**DOUBLE ACTING **VALVE END CONNECTION:**

STUDED FLANGED - BS4504 or SABS 1123
 THREADED - BSP MALE
 THREADED - NPT MALE
 STUDED FLANGED - ANSI B16.5

VALVE PRESSURE RATING:

PN10 (145 psi) ANSI #125
 PN16 (232 psi) ANSI #250

Note:

1. DN250 (10") and DN300 (12") valves are available on request.

TEST SPECIFICATION

All air release valves supplied shall be subjected to the following testing procedures in the order laid down:

- (A) A high pressure strength and leak test whereby the valve is filled with water and pressurized to twice the rated working pressure which shall be held for a period of 2 minutes. Any leaking, weeping or sweating shall be reason for rejection.
- (B) A low head leak test whereby the valve is filled with water and pressurized to a maximum of 0,5 bar (7.2 psi) using a visible water column connected to the test rig. The valve shall be rejected if leak tightness is not maintained for 2 minutes.
- (C) Every tenth air release valve of the same size and pressure rating must be subjected to a small orifice function test "DROP TEST" - whereby the valve is filled with water, pressurized to above rated working pressure and isolated from the test rig by closure of an isolating valve. A chamber in the test rig immediately prior to the isolating valve must be filled with compressed air at a pressure equal to that being maintained in the air release valve. The isolating valve is then opened so as to allow the air to rise in the air release valve without the pressure dropping lower than 2 - 3 bar (29 - 44 psi) above rated working pressure of the air release valve. The "DROP TEST" is then carried out by slowly bleeding off the pressure through a suitable cock until rated working pressure is reached and the float drops away from the orifice to allow discharge. Failure of the air release valve to function in the manner described will be reason for rejection.

On request the manufacturer shall provide batch certificates of test compliance which shall be cross referenced to serial numbers indelibly marked onto the identity label of each valve.

IMPORTANT NOTE: It is impossible to inject air into an incompressible liquid, air injection can only be achieved if the liquid can be displaced which implies that the pressure in the test rig must be reduced to atmospheric, and absolutely nothing is proven by discharge through the small orifice of the air release valve at atmospheric pressure. "DROP TESTING" in this manner is not acceptable.

OPERATION

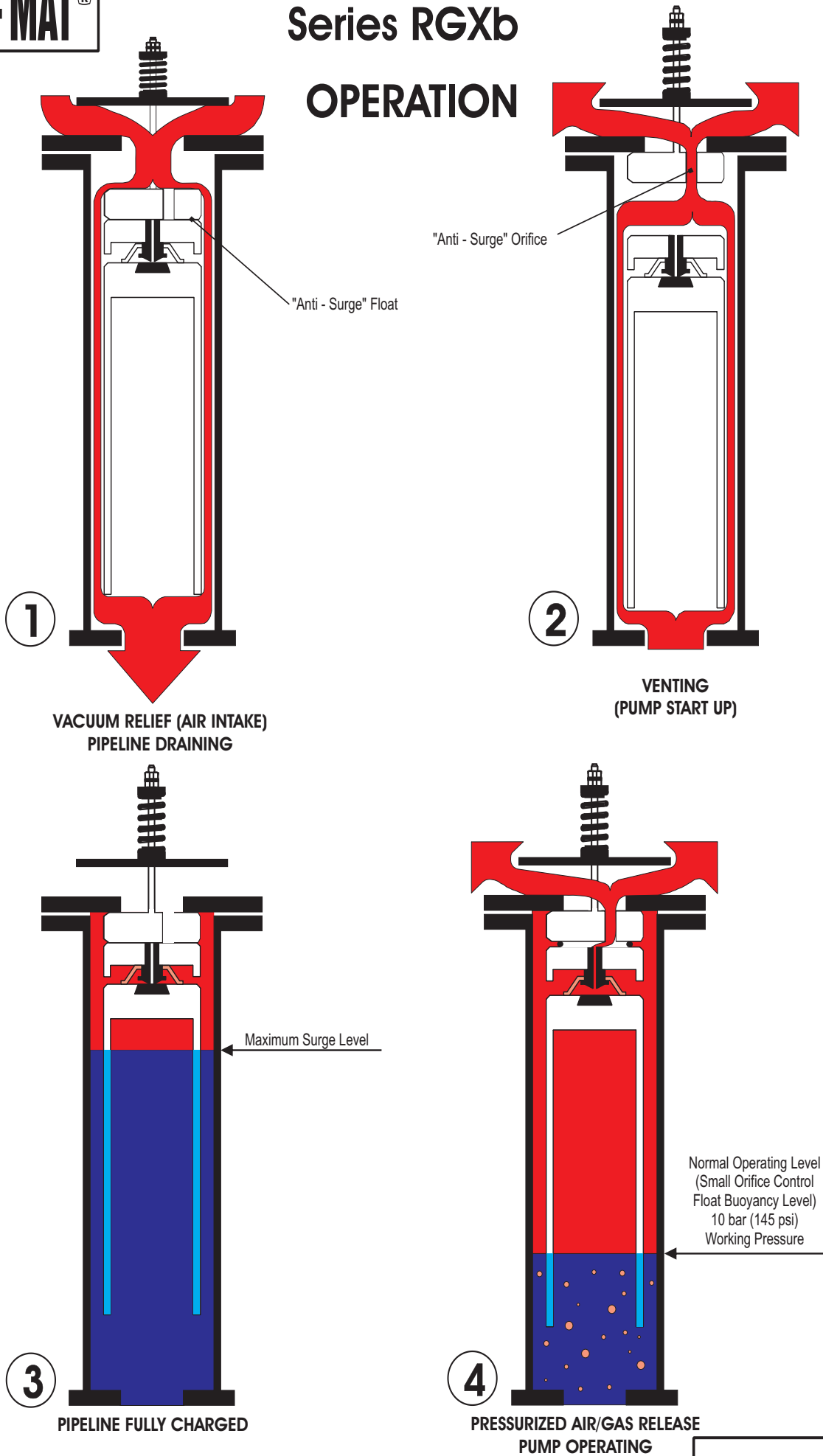

OPERATION**PRE NOTES:**

It is good engineering practice to install a sewage air valve prior to the pump discharge check valve, on vertical turbine pumps and deepwell submersible pump applications. The purpose of these valves is to control air/gas entry into the main pipeline on initial pump start up and to fully break vacuum in the vertical riser upon pump shutoff.

Operation of conventional sewage air valves in this application is such that the air in the vertical riser is released very rapidly upon pump startup, resulting in very high pressure transients when the liquid column slams the sewage air valve shut and/or slams into the closed discharge check valve.

The Vent-O-Mat Series RGXb valve has specifically been developed for use on deep well submersible pump and vertical turbine pump applications where they are installed prior to the pump discharge check valve to fulfill the following functions:

- Provide effective release of air/gas in the vertical riser upon pump startup.
- Dampen surge pressures upon startup.
- Provide vacuum protection when the pump stops and the vertical column drains.

VACUUM RELIEF (AIR INTAKE)

1. Upon pump stop, the discharge check valve closes. Sewage/effluent drains from the sewage air valve and the pump's vertical column. The negative differential created by the draining liquid causes atmospheric air to push the "Anti-Surge" Float down, opening the Large Orifice and allows air to displace the draining liquid to prevent potentially damaging internal negative pressure*.

The hollow smooth side float design, discourages the adherence of solids and viscous substances which, therefore tend to withdraw from the valve into the pipeline when draining occurs, for this reason **NO FLUSHING CONNECTIONS ARE NECESSARY**

VENTING (PUMP START UP)

2. Air/gas is forced through the "Anti-Surge" Orifice resulting in the deceleration of the approaching liquid column due to the resistance of rising air pressure in the valve.
This dampens transients when the sewage air valve closes and the liquid column opens the discharge check valve.

PRESSURIZED AIR RELEASE FROM A FULL PIPELINE

3. Sewage/effluent has entered the valve chamber and buoyed the floats to close both the "Anti-Surge" orifice and the small orifice. The design's compression/volume relationship prevents the media from ever exceeding the maximum surge level indicated in diagram 3. The resultant sewage/effluent free area protects against the fouling of the orifice seals by solids or high viscous substances - for this reason **NO FLUSHING CONNECTIONS ARE NECESSARY**.

PRESSURIZED AIR RELEASE (PUMP OPERATING)

4. The volume of disentrained air/gas increases in the valve and displaces the sewage/effluent level to the lower, normal operating level (small orifice control float buoyancy level) Any additional lowering of the sewage/effluent level, as would occur when more air/gas enters the valve, will result in the control float dropping away from the small orifice through which pressurized air/gas is then being discharged to atmosphere.

The control float will close the small orifice when sufficient air/gas has been released to restore the sewage/effluent level to the normal operating level.

The considerable sewage/effluent free area obviates the possibility of leaks that could otherwise be caused by solids entering the sealing areas - for this reason **NO FLUSHING CONNECTIONS ARE NECESSARY**

***Note:**

A differential pressure of less than 0.05 bar (0.7 psi) across the large orifice is required to open the valve fully under vacuum conditions.

RECOMMENDED INSTALLATION ARRANGEMENTS

VERTICAL TURBINE PUMP APPLICATION

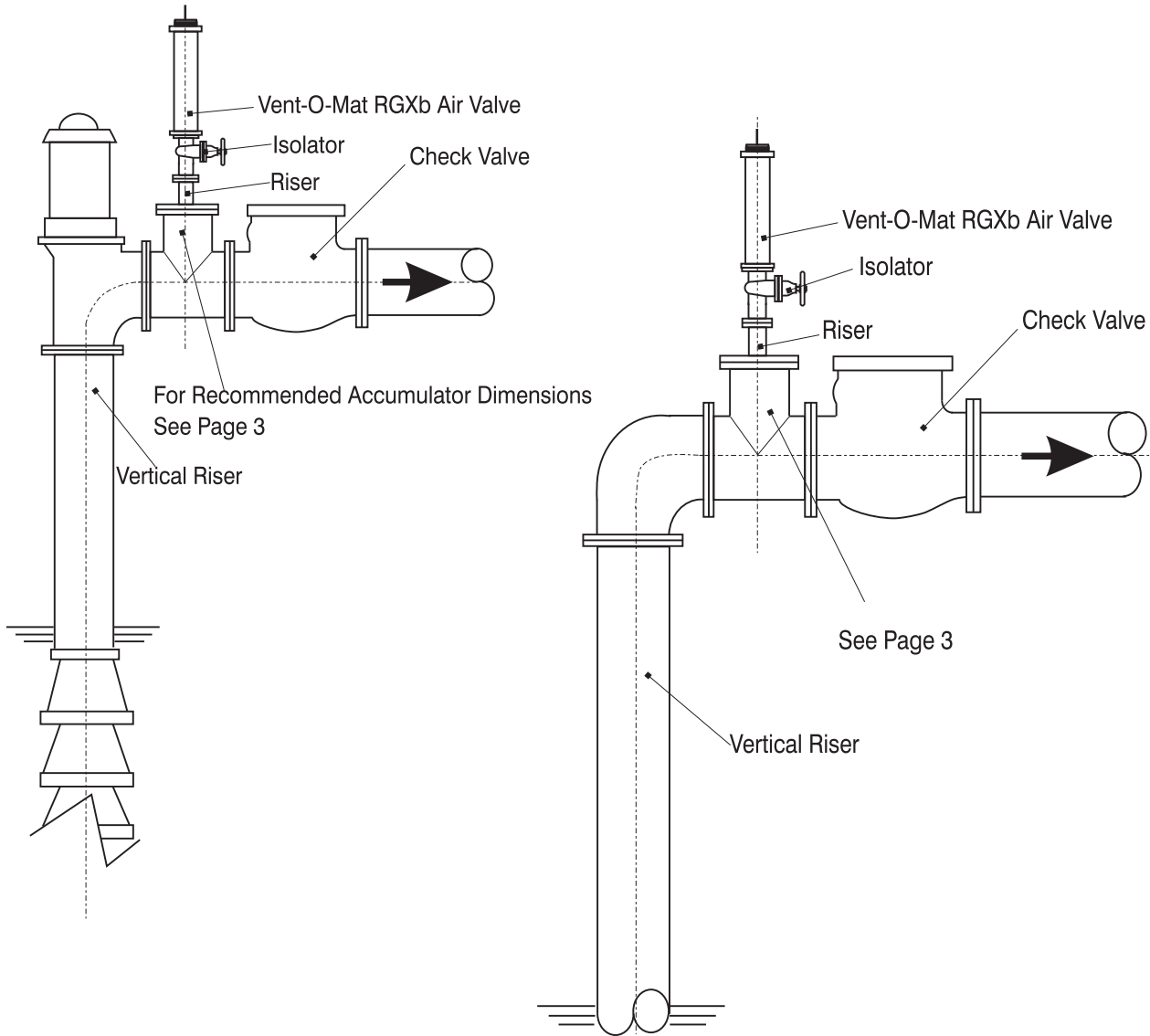

CENTRIFUGAL PUMP APPLICATION

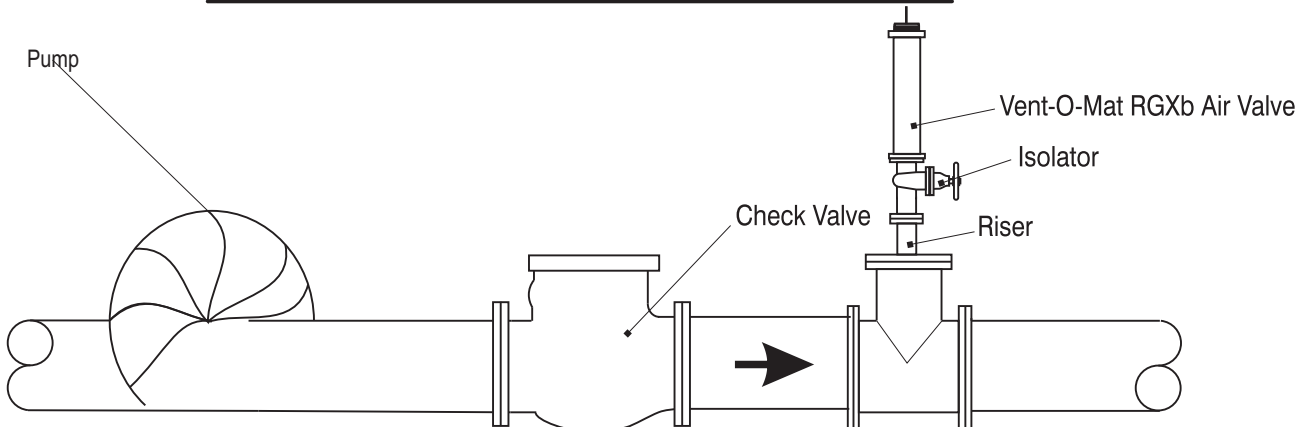

For Recommended Accumulator Dimensions

COMPONENT DESCRIPTION & MATERIAL SPECIFICATION THREADED 50 (2") & STUDED INLET - 80 (3)" TO 100 (4")

Type:
Series RGXb -Double Orifice (Small & Large Orifice)
with *Bias* Mechanism

End Connection:
Flange with Threaded BSP/NPT Male - 50 (2") valves.
Flange with Screwed Studs - 80 (3") & 100 (4") valves.

Nominal Sizes:
DN50 (2")
DN80 (3")
DN100 (4")

Model No's:
RGXb 1011/1021 _____
RGXb 1001/1031 _____

Pressure Ratings:
PN10 (145 psi)
PN10 (145 psi)

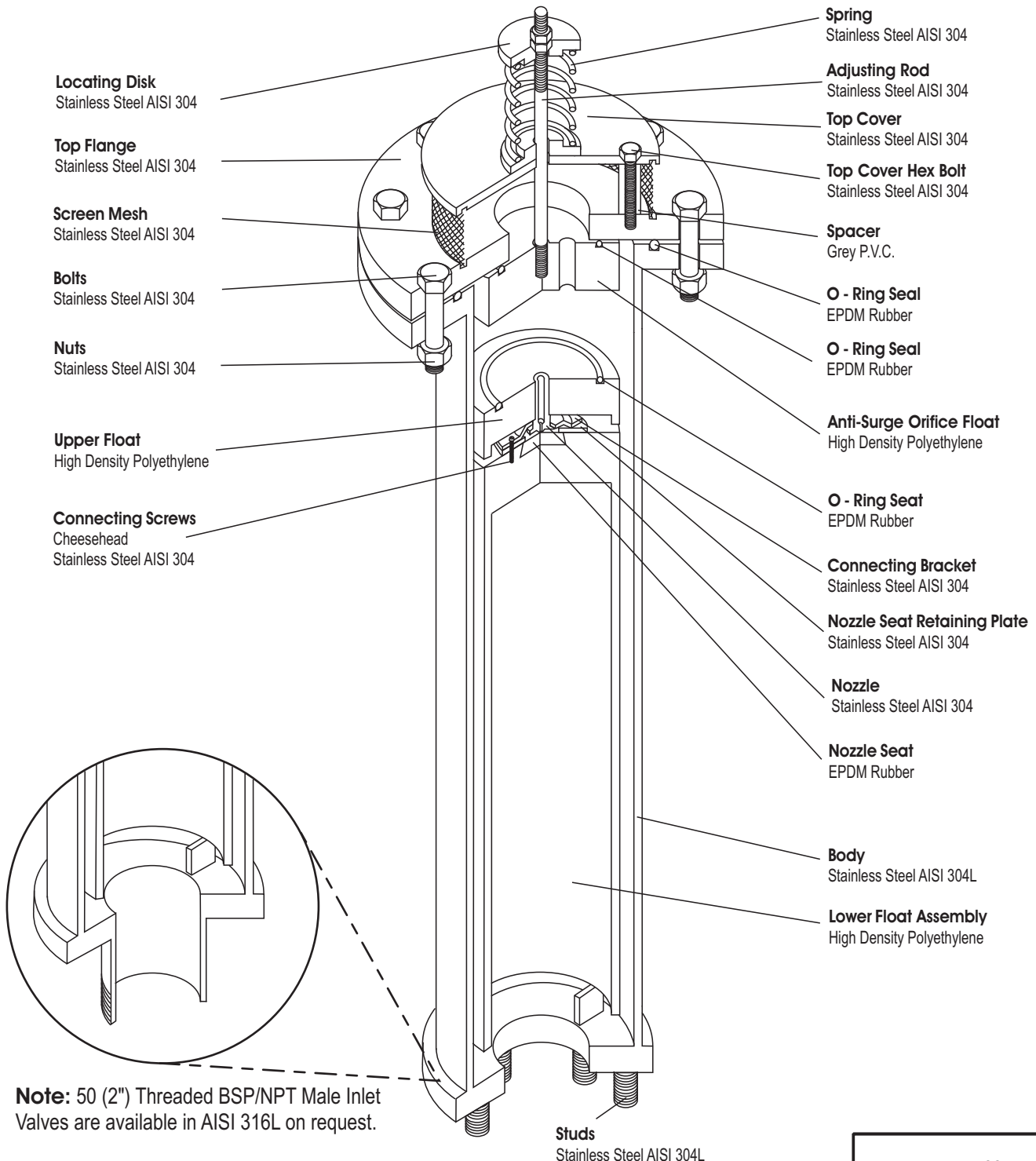

Note: 50 (2") Threaded BSP/NPT Male Inlet Valves are available in AISI 316L on request.

information subject to change without prior notice

COMPONENT DESCRIPTION & MATERIAL SPECIFICATION THREADED 50 (2") & STUDED INLET - 80 (3") TO 100 (4") EXPANDED BODY

Type:
 Series RGXb - Double Orifice (Small & Large Orifice)
 with *Bias* Mechanism

End Connection:
 Flange with Threaded BSP/NPT Male - 50 (2") valves.
 Flange with Screwed Studs - 80 (3") & 100 (4") valves

Nominal Sizes:
 DN50 (2")
 DN80 (3")
 DN100 (4")

Model No's:
 RGXb 1611/1621
 RGXb 1601/1631

Pressure Ratings:
 PN16 (232 psi)
 PN16 (232 psi)

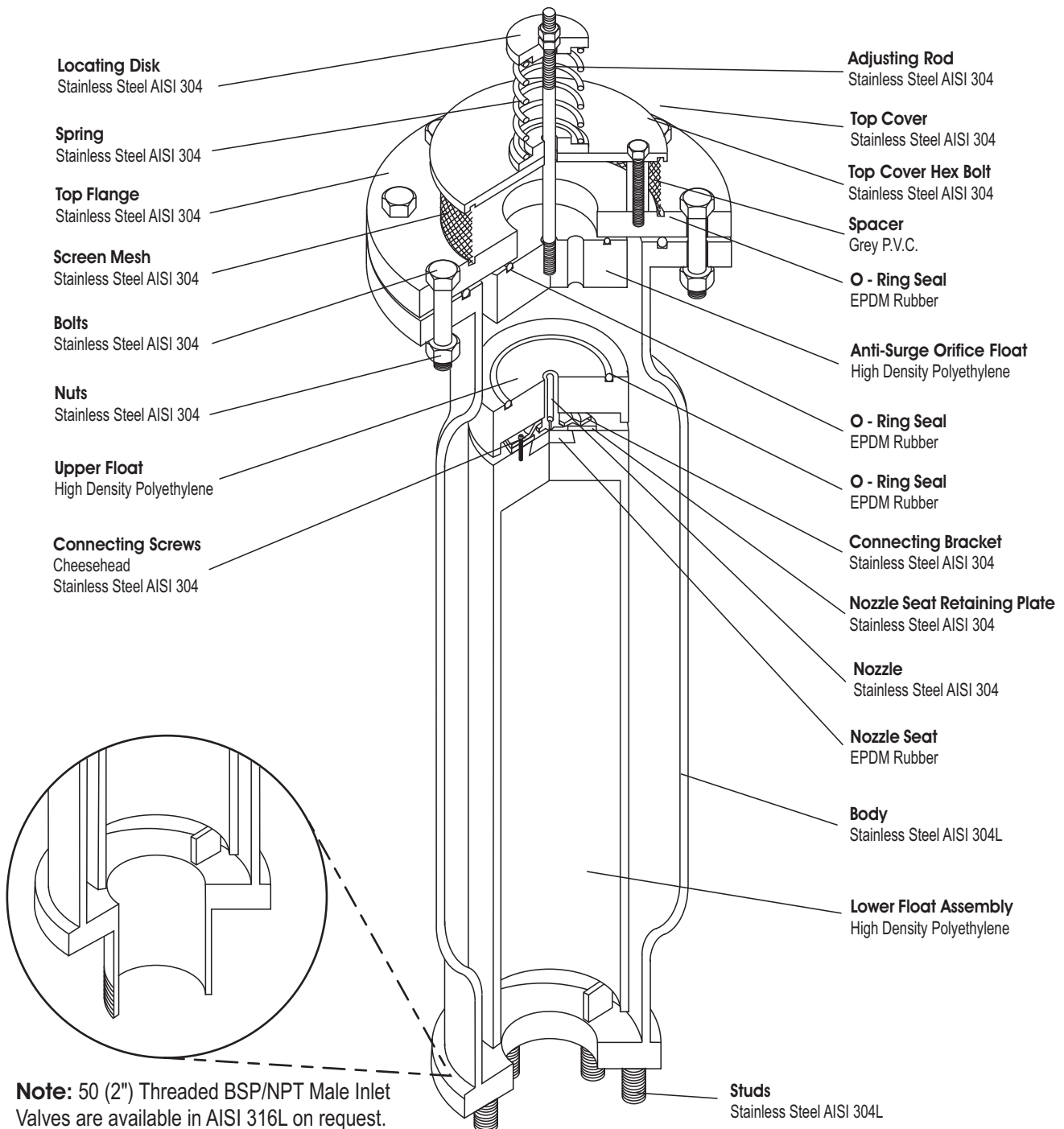

Note: 50 (2") Threaded BSP/NPT Male Inlet
 Valves are available in AISI 316L on request.

Series RGXb

COMPONENT DESCRIPTION & MATERIAL SPECIFICATION STUDED INLET - 150 (6") & 200 (8")

Type:
Series RGXb -Double Orifice (Small & Large Orifice)
with *Bias Mechanism*

End Connection:
Flange with Screwed Studs - 150 (6") & 200 (8") valves.

Nominal Sizes:
DN150 (6")
DN200 (8")

Model No's:
RGXb 1001/1031

Pressure Ratings:
PN10 (145 psi)

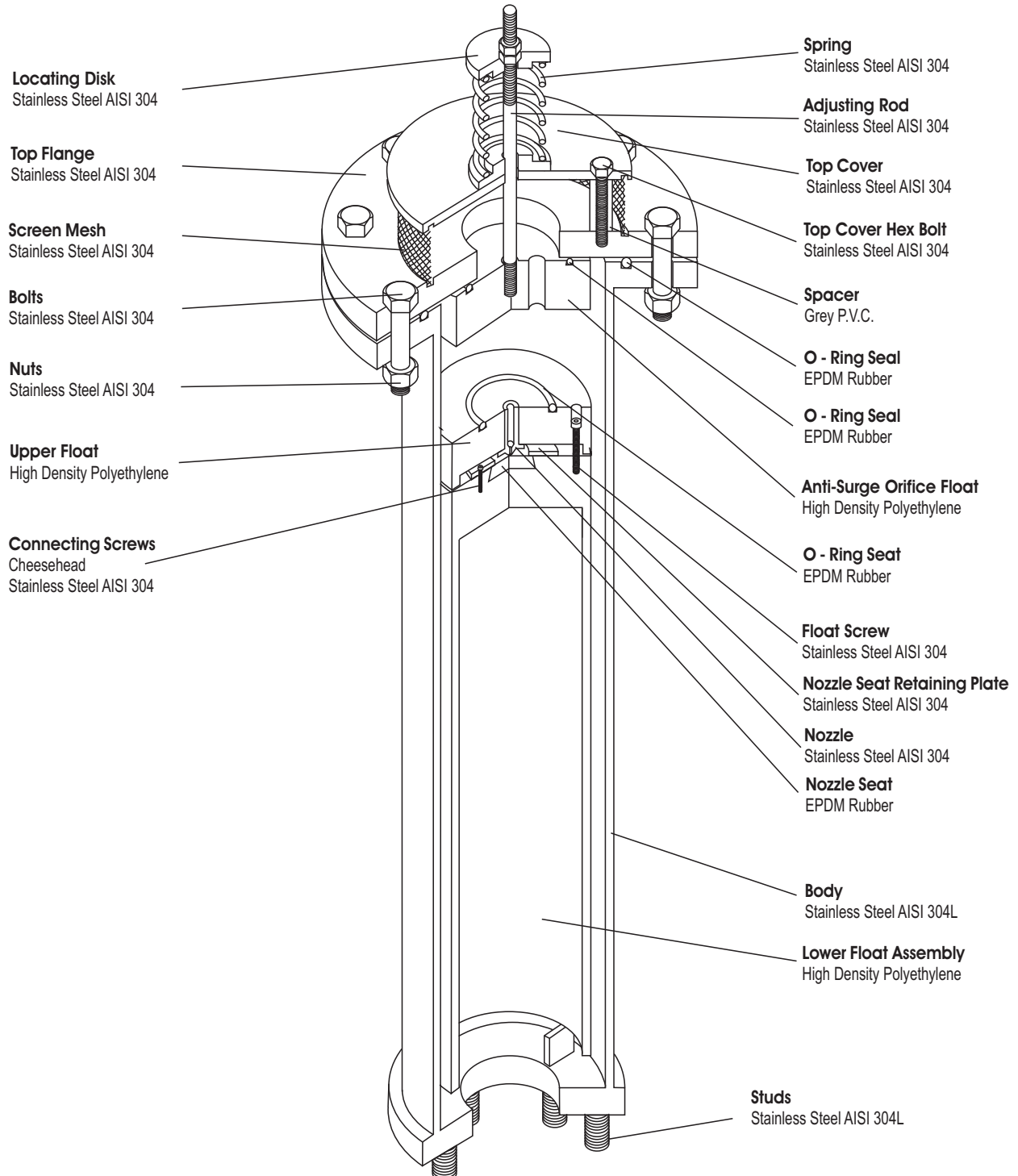

Series RGXb**COMPONENT DESCRIPTION & MATERIAL SPECIFICATION**
STUDED INLET - 150 (6") & 200 (8") EXPANDED BODY**Type:**Series RGXb - Double Orifice (Small & Large) with
*Bias Mechanism***End Connection:**

Flange with Screwed Studs - 150 (6") & 200 (8") valves.

Nominal Sizes:DN150 (6")
Dn200 (8")**Model No's:**

RGXb 1601/1631

Pressure Ratings:

PN16 (232 psi)

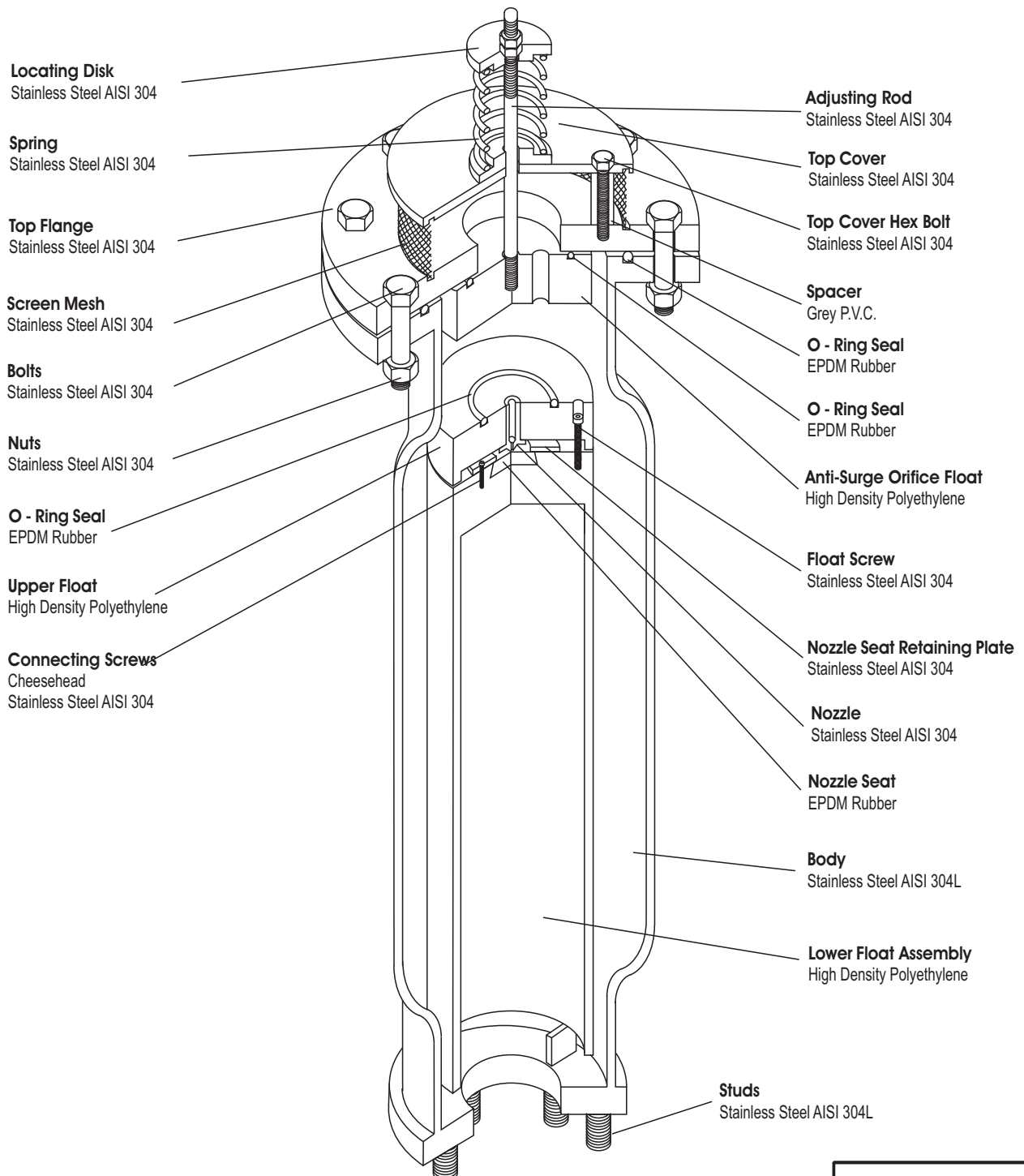

GENERAL SPECIFICATIONS

THREADED 50 (2") & STUDED INLET - 80 (3") TO 200 (8")

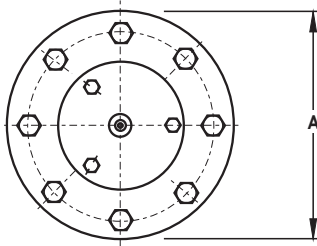

Type:

Double Orifice (Small & Large Orifice) with *Bias* mechanism for large volume air intake and controlled air discharge.

End Connection:

Flange with DN50 (2") Male BSP/NPT Threaded and Screwed Studs for Alignment to BS4504, SABS 1123 or ANSI B16.5 Class 150 for DN80 (3") to DN200 (8").

Nominal Sizes:

DN50 (2"), DN80 (3"), DN100 (4"), DN150 (6") & DN200 (8")

Model No's:

RGXb 1011/1021 _____

RGXb 1001/1031 _____

Pressure Ratings - bar (psi):

PN10 (145 psi)

PN10 (145 psi)

Operating Pressure Range - psi:

		Min	Max.
PN10 (145 psi)	_____	0.5 (7.2)	10 (145)

Function:

- i) High volume air intake - pipeline draining
- ii) Pressurized air/gas discharge - pipeline filled.
- iii) Controlled air discharge - pipeline filling.
- iv) Surge dampening - high velocity air/gas discharge, liquid column separation & liquid oscillation.

Valve Selection:- see pages 11 & 12

Materials of Construction:- see pages 22 & 24

Installation:- see page 21

Standard Factory Tests:

- i) Hydrostatic test -1.5 x max. rated working pressure
- ii) Low head leak test - 0.5 bar (7.2 psi)
- iii) Small orifice function test at max. rated working pressure (minimum 1 valve in 10).

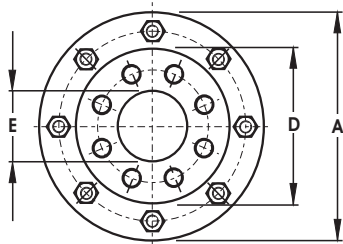
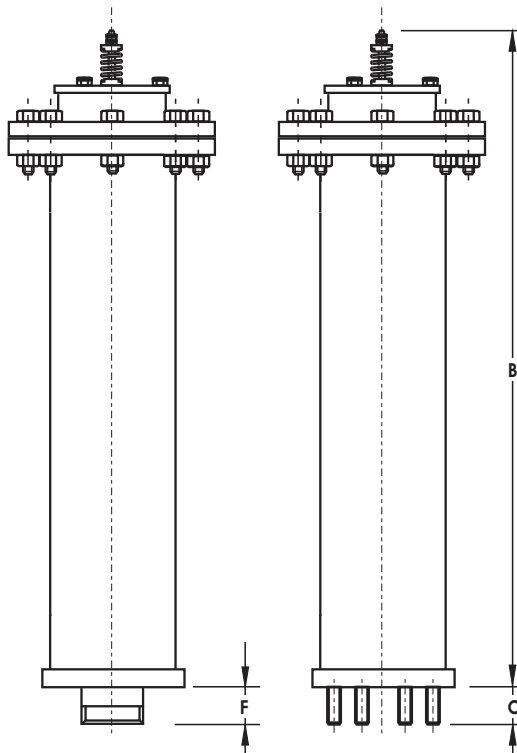

OVERALL DIMENSIONS & WEIGHTS

DN		Model No.	A		B		C		D		E		F		Weight	
mm	in		mm	in	mm	in	mm	in	mm	in	mm	in	mm	in	kg	lbs
50	2	050 RGXb 1011 & 1021	220	8 2/3	850	33 7/16	N/A		125	5	50	2	42	1 2/3	18.1	39.9
80	3	080 RGXb 1001 & 1031	285	11 1/4	885	34 7/8	55	2 1/8	200	7 7/8	80	3	N/A		36.7	80.9
100	4	100 RGXb 1001 & 1031	285	11 1/4	885	34 7/8	55	2 1/8	220	8 2/3	100	4	N/A		36.2	79.8
150	6	150 RGXb 1001 & 1031	395	15 9/16	1230	48 4/10	55	2 1/8	285	11	150	6	N/A		82.4	181.7
200	8	200 RGXb 1001 & 1031	445	17 1/2	1230	48 4/10	55	2 1/8	340	13 5/16	200	8	N/A		103.4	227.9

GENERAL SPECIFICATIONS

THREADED 50 (2") & STUDED INLET - 80 (3") TO 200 (8") EXPANDED BODY

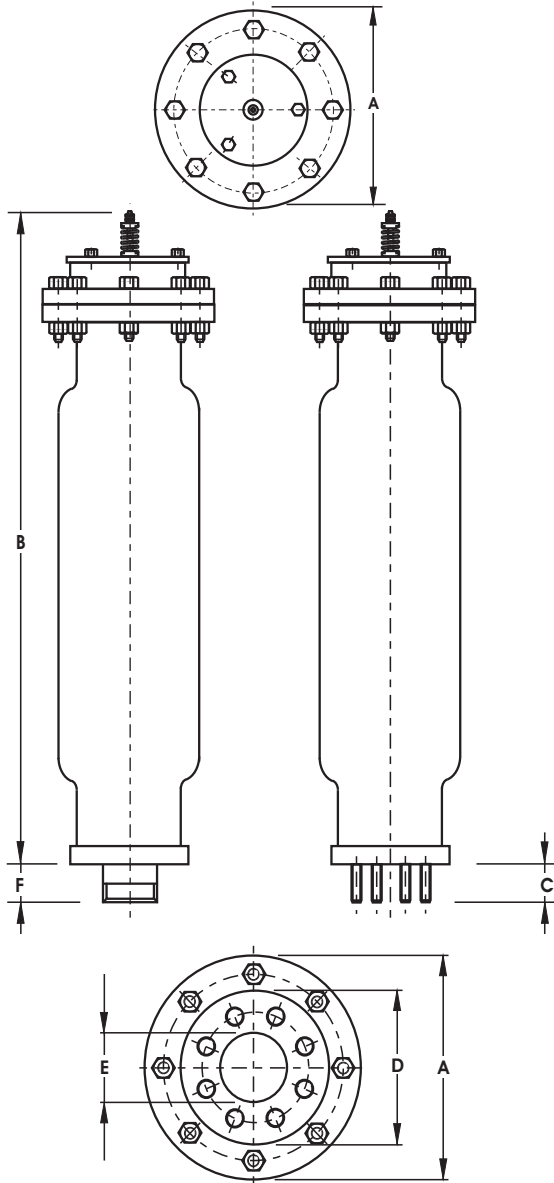

Type:

Double Orifice (Small & Large Orifice) with *Bias* mechanism for large volume air intake and controlled air discharge.

End Connection:

Flange with DN50 (2") Male BSP/NPT Threaded and Screwed Studs for Alignment to BS4504, SABS 1123 or ANSI B16.5 Class 150 & Class 300 for DN80 (3") to DN200 (8").

Nominal Sizes:

DN50 (2"), DN80 (3"), DN100 (4"), DN150 (6") & DN200 (8")

Model No's:

RGXb 1611/1621
RGXb 1601/1631

Pressure Ratings - bar (psi):

PN16 (232 psi)
PN16 (232 psi)

Operating Pressure Range - bar (psi):

	Min	Max.
PN16 (232 psi)	0.5 (7.2)	16 (232)

Function:

- i) High volume air intake - pipeline draining
- ii) Pressurized air/gas discharge - pipeline filled.
- iii) Surge dampening - high velocity air/gas discharge, Liquid column separation & liquid oscillation

Valve Selection:- see pages 11 & 12

Materials of Construction:- see pages 23 & 25

Standard Factory Tests:

- i) Hydrostatic test -1.5 x max. rated working pressure.
- ii) Low head leak test - 0.5 bar (7.2 psi).
- iii) Small orifice function test at max. rated working pressure (minimum 1 valve in 10).

OVERALL DIMENSIONS & WEIGHTS

DN		Model No.	A		B		C		D		E		F		Weight	
mm	in		mm	in	mm	in	mm	in	mm	in	mm	in	mm	in	kg	lbs
50	2	050 RGXb 1011 & 1021	220	8 2/3	850	33 7/16	N/A		125	5	50	2	42	1 2/3	21	46.5
80	3	080 RGXb 1001 & 1031	285	11 1/4	885	34 7/8	55	2 1/8	200	7 7/8	80	3	N/A		38	84.1
100	4	100 RGXb 1001 & 1031	285	11 1/4	885	34 7/8	55	2 1/8	220	8 2/3	100	4	N/A		37.5	83
150	6	150 RGXb 1001 & 1031	395	15 9/16	1230	48 4/10	55	2 1/8	285	11	150	6	N/A		85	187.2
200	8	200 RGXb 1001 & 1031	445	17 1/2	1230	48 4/10	55	2 1/8	340	13 6/16	200	8	N/A		105.8	233.4

PURCHASE SPECIFICATION**VENT-O-MAT MODEL NO.**

Page 26 - Series RGXb - DN50 (2") to DN200 (8").

Page 27 - Series RGXb - DN50 (2") to DN200 (8") (Expanded Body).

CONSTRUCTION & DESIGN

The Sewage Air Release & Vacuum Break Valve shall consist of a compact tubular all stainless steel fabricated body, hollow direct acting float and solid large orifice float in H.D.P.E. - stainless steel nozzle and woven dirt inhibitor screen, EPDM rubber seals and seat.

The valve shall have an integral 'Anti-Surge' Orifice mechanism which shall operate automatically to limit surge pressures or shock induced by liquid oscillation and/or rapid air/gas discharge to less than 1.5 x valve rated working pressure.

The intake orifice area shall be equal to the nominal size of the valve i.e., a DN150 (6") valve shall have a DN150 (6") intake orifice. Large orifice sealing shall be effected by the flat face of the control float seating against a EPDM rubber 'O' ring housed in a dovetail groove circumferentially surrounding the orifice.

Discharge of pressurized air shall be controlled by the seating & unseating of a small orifice nozzle on a EPDM rubber seal affixed into the control float. The nozzle shall have a flat seating land surrounding the orifice so that damage to the rubber seal is prevented.

The valve construction shall be proportioned with regard to material strength characteristics, so that deformation, leaking or damage of any kind does not occur by submission to twice the designed working pressure

Connection to the valve inlet shall be facilitated by flanged ends conforming to PN10, 16 or 25 ratings of BS4504 or SABS 1123 Standards or ANSI B16.5 Class 150 or Class 300 Standards. Flanged ends shall be supplied with the requisite number of stainless steel screwed studs inserted for alignment to the specified standard. **Nuts and washers shall be excluded.**

OPERATION

1. Prior to the ingress of liquid into the valve chamber, as when the pipeline is being filled, valves shall vent through the "Anti-Surge" orifice when sewage/effluent approach velocities are relative to a transient pressure rise, on valve closure, of < 1.5 x valve rated pressure.
2. Valves shall not exhibit leaks or weeping of liquid past the large orifice seal at operating pressures of 0.5 bar (7.2 psi) to 1.5 x rated working pressure.
3. Valves shall respond to the presence of air/gas by discharging it through the small orifice at any pressures within a specified design range, i.e. 0.5 bar (7.2 psi) to 10 bar (145 psi) and shall remain leak tight in the absence of air.
4. Valves shall react immediately to pipeline drainage or water column separation by the full opening of the large orifice so as to allow unobstructed air intake at the lowest possible negative internal pipeline pressure.

OPERATION

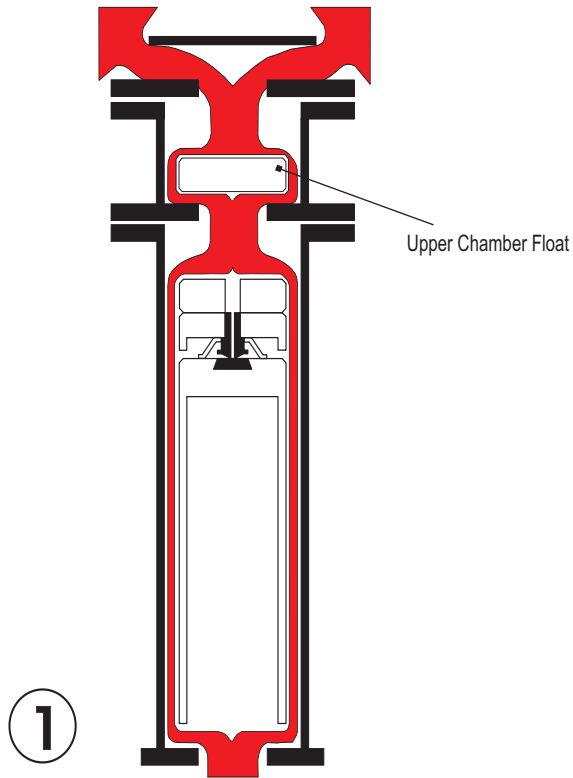

VENTING OF A FILLING PIPELINE
(SUB CRITICAL SEWAGE/ EFFLUENT
APPROACH VELOCITY)

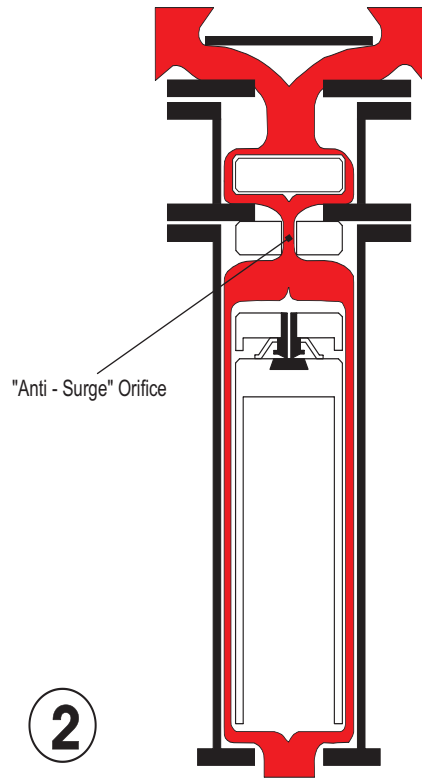

VENTING OF A FILLING PIPELINE
(EXCESSIVE SEWAGE/ EFFLUENT
APPROACH VELOCITY)

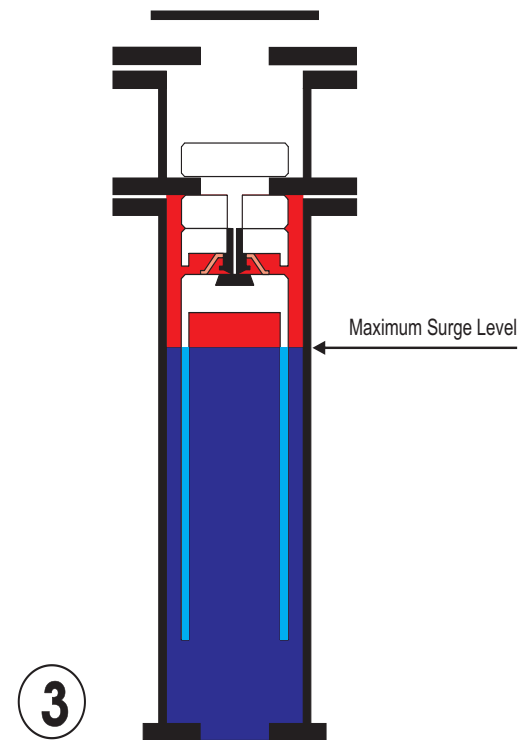

PIPELINE FULLY CHARGED

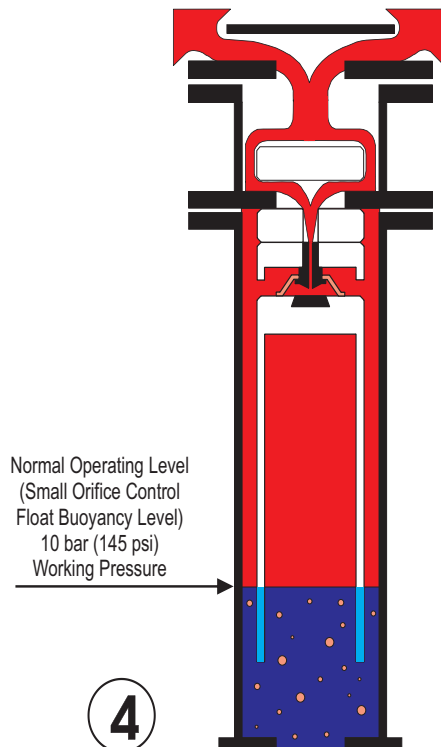

PRESSURIZED AIR/GAS RELEASE
FROM A FULL PIPELINE

OPERATION**PRE NOTES:**

There are instances where the hydraulic gradeline falls below a peak point during normal operation and where air inflow would adversely affect the normal operation and surge characteristic of the pipeline.

Vent-O-Mat offers the Series RGXv valve which has specifically been developed to ensure effective air/gas release under all pipeline conditions but will not allow air entry into the pipeline.

1. **VENTING OF A FILLING PIPELINE (SUB CRITICAL LIQUID APPROACH VELOCITY)**
Air/gas flows through the annular space between the cylindrical floats and discharges through the Large Orifice into atmosphere.*
2. **VENTING OF A FILLING PIPELINE (EXCESSIVE LIQUID APPROACH VELOCITY)**
In reaction to increased air/gas flow, "Anti Surge" Float closes the large orifice and air is forced through the "Anti-Surge" orifice resulting in deceleration of the approaching liquid due to the resistance of rising air/gas pressure in the valve.
3. **PRESSURIZED AIR/GAS RELEASE FROM A FULL PIPELINE**
Sewage/effluent has entered the valve chamber and buoyed the floats to close both the "Anti-Surge" orifice and the small orifice. The design's compression/volume relationship prevents the media from ever exceeding the maximum surge level indicated in diagram 3.

The resultant sewage/effluent free area protects against the fouling of the orifice seals by solids or high viscous substances - for this reason NO FLUSHING CONNECTIONS ARE NECESSARY.

4. **PRESSURIZED AIR/GAS RELEASE (PUMP OPERATING)**
The volume of disentrained air/gas increases in the valve and displaces the sewage/effluent level to the lower, normal operating level (small orifice control float buoyancy level) Any additional lowering of the sewage/effluent level, as would occur when more air/gas enters the valve, will result in the control float dropping away from the small orifice through which pressurized air/gas is then being discharged to atmosphere.

The control float will close the small orifice when sufficient air/gas has been released to restore the sewage/effluent level to the normal operating level.

The considerable sewage/effluent free area obviates the possibility of leaks that could otherwise be caused by solids entering the sealing areas - for this reason NO FLUSHING CONNECTIONS ARE NECESSARY

***Note:**

A relatively low flow discharge rate is required to lift the upper chamber float and ensure air release . The Upper Chamber Float will seat on the Middle Flange under vacuum conditions, effectively preventing air entry.

COMPONENT DESCRIPTION & MATERIAL SPECIFICATION THREADED 50 (2") & STUDED INLET - 80 (3") TO 100 (4")

Type:
Series RGXv - Triple Orifice with "Anti-Surge"
Mechanism

End Connection:
Flange with Threaded BSP/NPT Male - 50 (2") valves.
Flange with Screwed Studs - 80 (3") & 100 (4") valves.

Nominal Sizes:

DN50 (2")
DN80 (3")
DN100 (4")

Model No's:

RGXv 1011/1021
RGXv 1001/1031

Pressure Ratings:

_____ PN10 (145 psi)
_____ PN10 (145 psi)

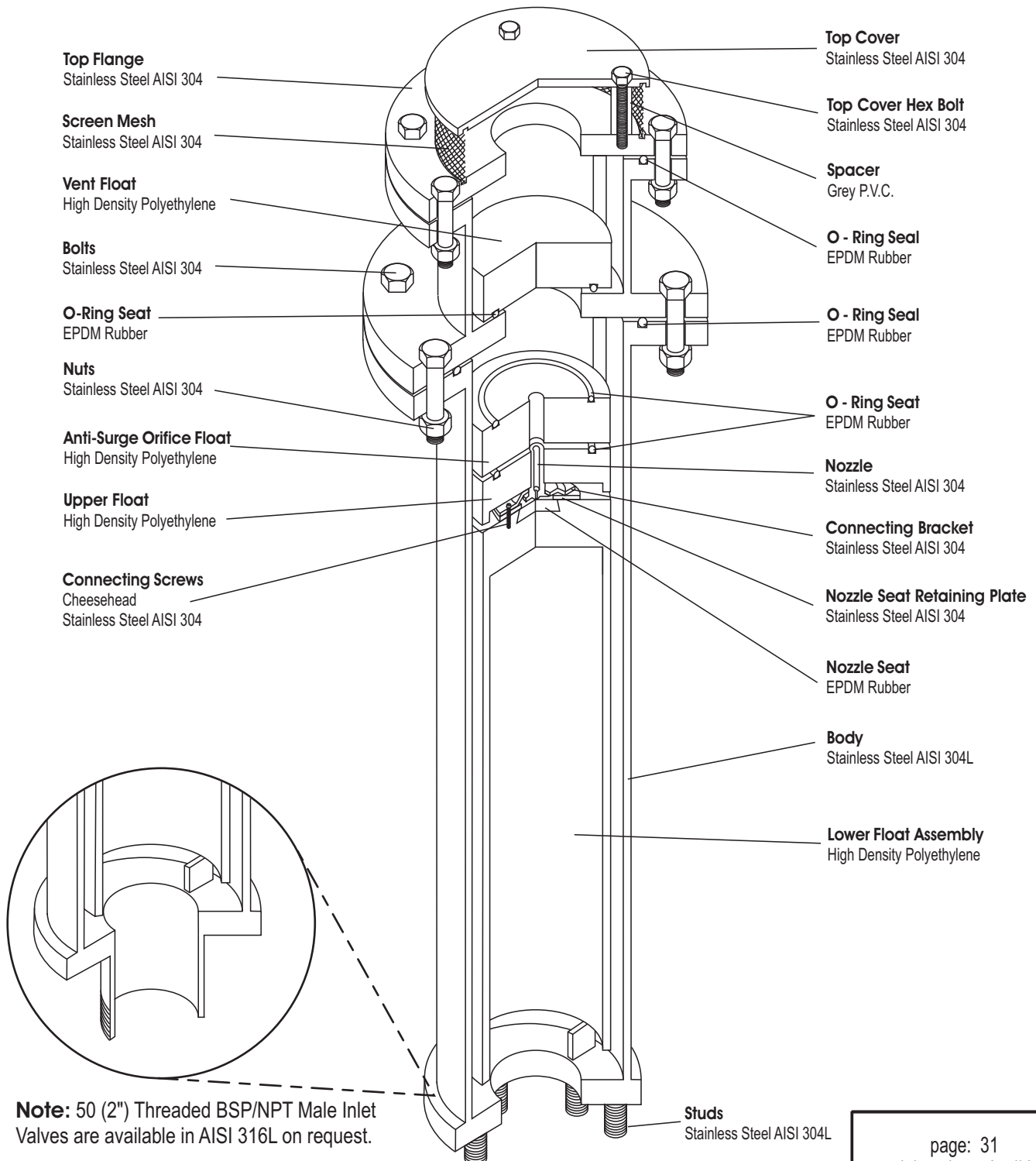

Note: 50 (2") Threaded BSP/NPT Male Inlet
Valves are available in AISI 316L on request.

information subject to change without prior notice

COMPONENT DESCRIPTION & MATERIAL SPECIFICATION THREADED 50 (2") & STUDED INLET - 80 (3") TO 100 (4") EXPANDED BODY

Type:
 Series RGXv - Triple Orifice with "Anti-Surge"
 Mechanism

End Connection:
 Flange with Threaded BSP/NPT Male - 50 (2") valves.
 Flange with Screwed Studs - 80 (3") & 100 (4") valves.

Nominal Sizes:
 DN50 (2")
 Dn80 (3")
 DN100 (4")

Model No's:
 RGXv 1611/1621
 RGXv 1601/1631

Pressure Ratings:
 PN16 (232 psi)
 PN16 (232 psi)

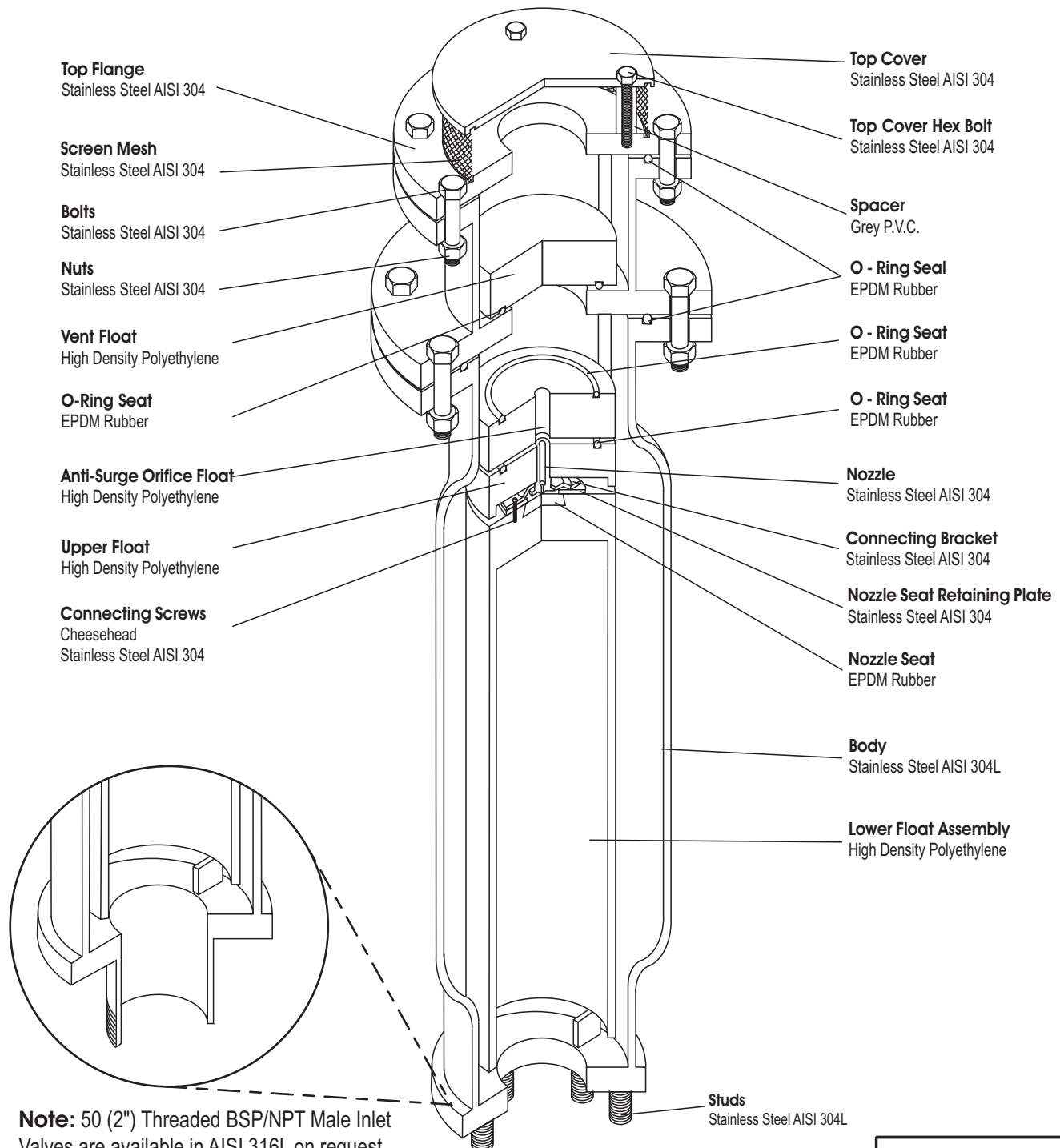

Note: 50 (2") Threaded BSP/NPT Male Inlet Valves are available in AISI 316L on request.

COMPONENT DESCRIPTION & MATERIAL SPECIFICATION
STUDED INLET - 150 (6") & 200 (8")**Type:**Series RGXv - Triple Orifice with "Anti-Surge"
Mechanism.**End Connection:**

Flange with Screwed Studs - 150 (6") & 200 (8") valves.

Nominal Sizes:

DN150 (6")

DN200 (8")

Model No's:

RGXv 1001/1031 _____

Pressure Ratings:

PN10 (145 psi)

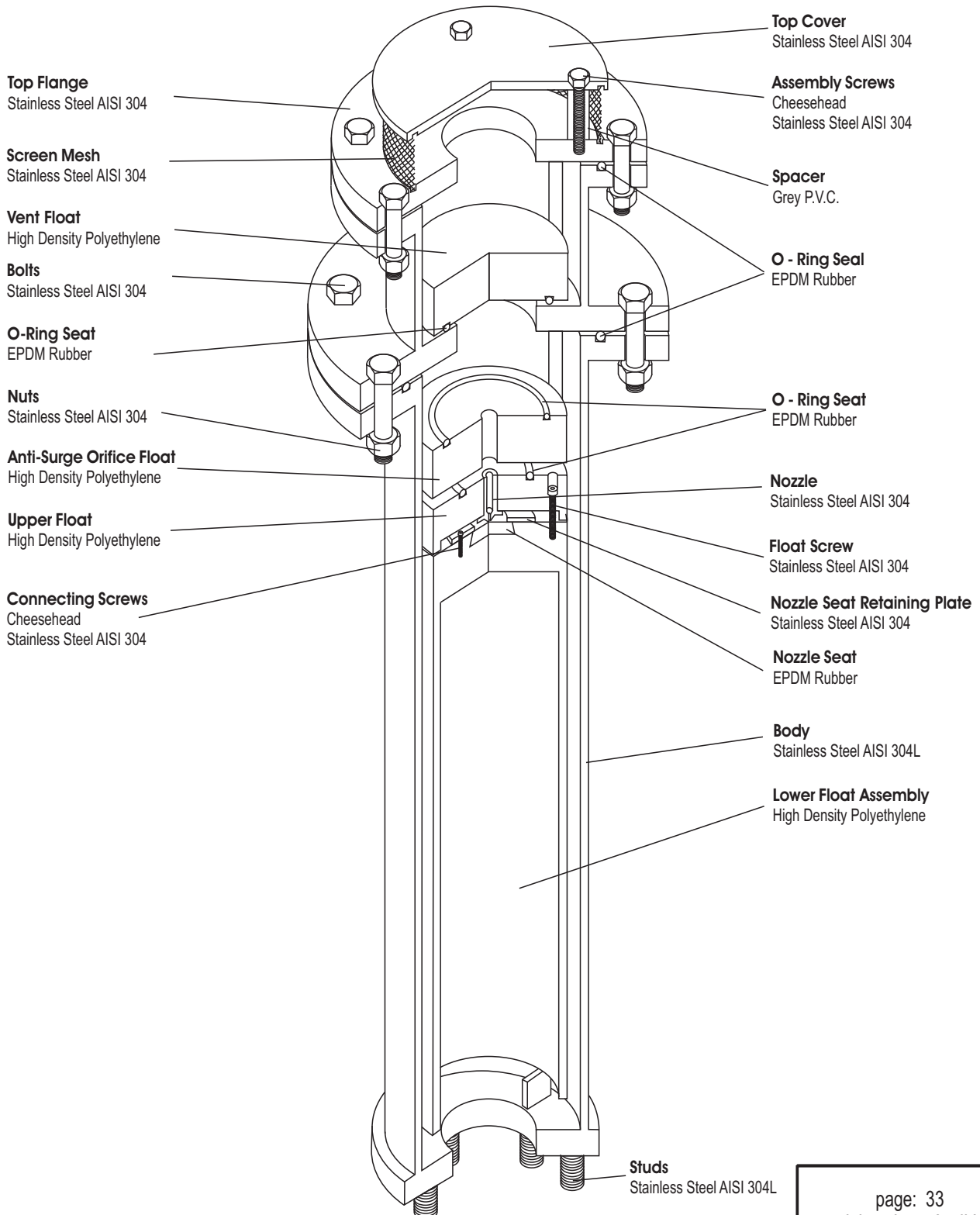

COMPONENT DESCRIPTION & MATERIAL SPECIFICATION STUDED INLET - 150 (6") & 200 (8") EXPANDED BODY

Type:
Series RGXv - Triple Orifice with "Anti-Surge"
Mechanism.

End Connection:
Flange with Screwed Studs - 150 (6") & 200 (8") valves.

Nominal Sizes:
DN150 (6")
Dn200 (8")

Model No's:
RGXv 1601/1631

Pressure Ratings:
PN16 (232 psi)

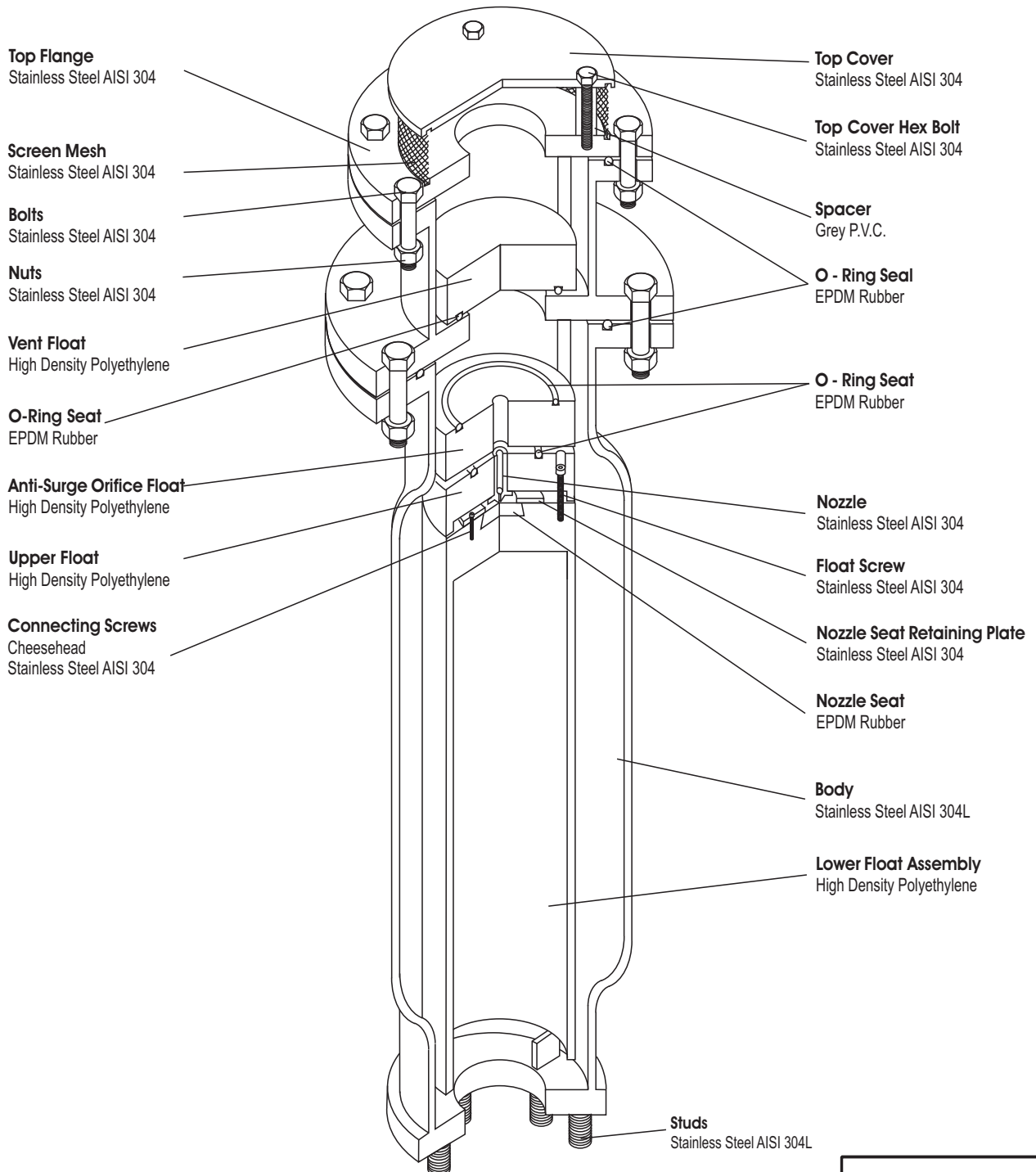

GENERAL SPECIFICATIONS

THREADED 50 (2") & STUDED INLET - 80 (3") TO 200 (8")

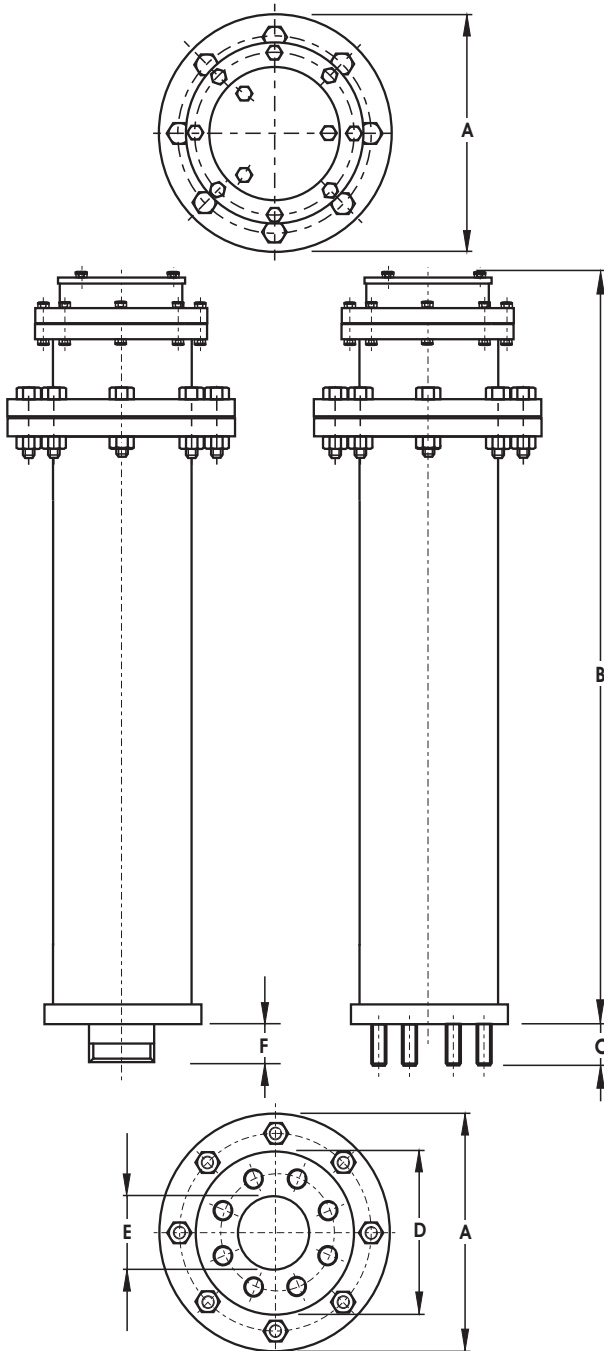

Type:

Triple Orifice with *Bias* mechanism for air/gas discharge but not air re-entry.

End Connection:

Flange with DN50 (2") Male BSP/NPT Threaded and Screwed Studs for Alignment to BS4504, SABS1123 or ANSI B16.5 Class 150 for DN80 (3") to DN200 (8").

Nominal Sizes:

DN50 (2"), DN80 (3"), DN100 (4"), DN150 (6") & DN200 (8")

Model No's:

RGXb 1011/1021 _____
 RGXb 1001/1031 _____

Pressure Ratings - bar (psi):

PN10 (145 psi)
 PN10 (145 psi)

Operating Pressure Range - bar (psi):

	Min		Max.
PN10 (145 psi)	0.5 (7.2)	_____	10 (145)

Function:

- i) High volume air/gas discharge - pipeline filling.
- ii) Pressurized air/gas discharge - pipeline filled.
- iii) Surge dampening - high velocity air/gas discharge, liquid column separation & liquid oscillation.

Valve Selection:- see pages 11 & 12

Materials of Construction:- see pages 31 & 33

Installation:- see page 3

Standard Factory Tests:

- i) Hydrostatic test - 1.5 x max. Rated working pressure
- ii) Low head leak test - 0.5 bar (7,2 psi)
- iii) Small orifice function test at max. rated working pressure (minimum 1 valve in 10).

OVERALL DIMENSIONS & WEIGHTS

DN		Model No.	A		B		C		D		E		F		Weight	
mm	in		mm	in	mm	in	mm	in	mm	in	mm	in	mm	in	kg	lbs
50	2	050 RGXv 1011 & 1021	220	8 2/3	862	34	N/A		125	5	50	2	42	1 2/3	18.1	39.9
80	3	080 RGXv 1001 & 1031	285	11 1/4	872	34 1/3	55	2 1/8	200	7 7/8	80	3	N/A		36.7	80.9
100	4	100 RGXv 1001 & 1031	285	11 1/4	872	34 1/3	55	2 1/8	220	8 2/3	100	4	N/A		36.2	79.8
150	6	150 RGXv 1001 & 1031	395	15 9/16	1225	48 2/10	55	2 1/8	285	11	150	6	N/A		82.4	181.7
200	8	200 RGXv 1001 & 1031	445	17 1/2	1225	48 2/10	55	2 1/8	340	13 5/16	200	8	N/A		103.4	227.9

Note: DN50 (2") valves have DN50 (2") BSP/NPT male inlet connections as standard.

information subject to change without prior notice

GENERAL SPECIFICATIONS

THREADED 50 (2") & STUDED INLET - 80 (3") TO 200 (8") EXPANDED BODY

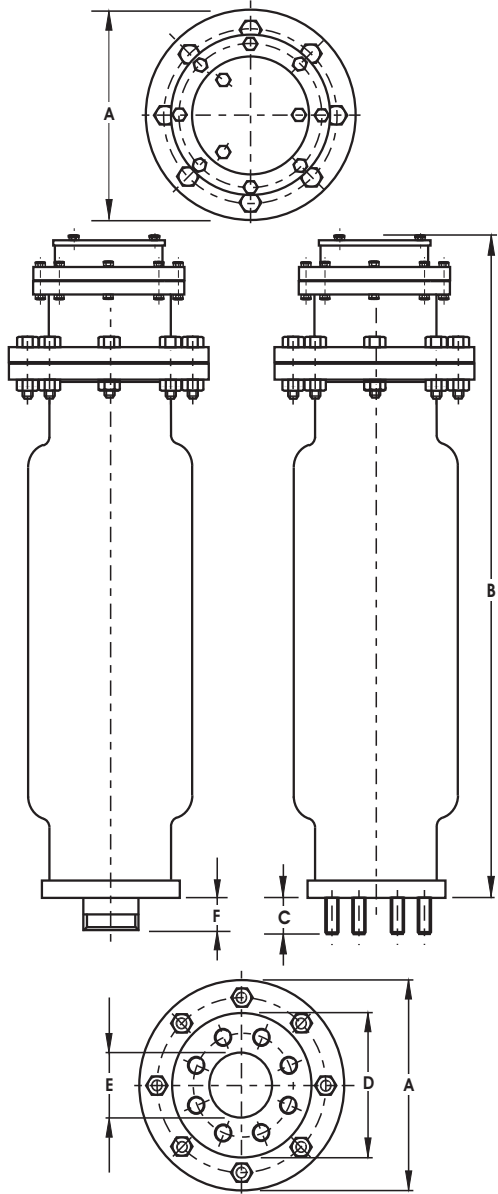

Type:

Triple Orifice with Bias mechanism for air/gas discharge but not air re-entry.

End Connection:

Flange with DN50 (2") Male BSP/NPT Threaded and Screwed Studs for Alignment to BS4504, SABS1123 or ANSI B16.5 Class 150 & Class 300 for DN80 (3") to DN200 (8").

Nominal Sizes:

DN50 (2"), DN80 (3"), DN100 (4"), DN150 (6") & DN200 (8")

Model No's:

RGXb 1611/1621
RGXb 1601/1631

Pressure Ratings - psi:

16 (232 psi)
16 (232 psi)

Operating Pressure Range - psi:

16 (232 psi) _____ Min 0.5 (7.2) _____ Max. 16 (232)

Function:

- i) High volume air/gas discharge - pipeline filling
- ii) Pressurized air/gas discharge - pipeline filled.
- iii) Surge dampening - high velocity air/gas discharge, liquid column separation & liquid oscillation.

Valve Selection:- see pages 11 & 12

Materials of Construction:- see pages 32 & 34

Installation:- see page 3

Standard Factory Tests:

- i) Hydrostatic test -1.5 x max. rated working pressure
- ii) Low head leak test - 0.5 bar (7.2 psi)
- iii) Small orifice function test at max. rated working pressure (minimum 1 valve in 10).

OVERALL DIMENSIONS & WEIGHTS

DN	Model No.		A		B		C		D		E		F		Weight	
	mm	in	mm	in	mm	in	mm	in	mm	in	mm	in	mm	in	kg	lbs
50	2	050 RGXv 1011 & 1021	220	8 2/3	862	34	N/A		125	5	50	2	42	1 2/3	25.5	56.2
80	3	080 RGXv 1001 & 1031	285	11 1/4	872	34 1/3	55	2 1/8	200	7 7/8	80	3	N/A		44.5	98
100	4	100 RGXv 1001 & 1031	285	11 1/4	872	34 1/3	55	2 1/8	220	8 2/3	100	4	N/A		44	96.9
150	6	150 RGXv 1001 & 1031	395	15 9/16	1225	48 2/10	55	2 1/8	285	11	150	6	N/A		99	218.7
200	8	200 RGXv 1001 & 1031	445	17 1/2	1225	48 2/10	55	2 1/8	340	13 6/16	200	8	N/A		120	264.5

Note: DN50 (2") valves have DN50 (2") BSP/NPT male inlet connections as standard.

information subject to change without prior notice

page: 36
revision date: April '10

PURCHASE SPECIFICATION

VENT -O- MAT MODEL NO.

Page 35 - Series RGXv - 50 (2") to 200 (8").

Page 36 - Series RGXv - 50 (2") to 200 (8") (Expanded Body).

CONSTRUCTION & DESIGN

The Sewage Air Release & Vacuum Break Valve shall consist of a compact tubular all stainless steel fabricated body, hollow direct acting float and solid large orifice float in H.D.P.E. - stainless steel nozzle and woven dirt inhibitor screen, EPDM rubber seals and seat.

The valve shall have an integral "Anti - Surge" Orifice mechanism which shall operate automatically to limit transient pressure rise or shock induced by closure to less than 1.5 x valve rated working pressure.

The intake orifice area shall be equal to the nominal size of the valve i.e., a DN150 (6") valve shall have a DN150 (6") intake orifice. Large orifice sealing shall be effected by the flat face of the control float seating against a EPDM rubber 'O' ring housed in a dovetail groove circumferentially surrounding the orifice.

Discharge of pressurized air shall be controlled by the seating & unseating of a small orifice nozzle on a natural rubber seal affixed into the control float. The nozzle shall have a flat seating land surrounding the orifice so that damage to the rubber seal is prevented.

The valve construction shall be proportioned with regard to material strength characteristics, so that deformation, leaking or damage of any kind does not occur by submission to twice the designed working pressure.

Connection to the valve inlet shall be facilitated by flanged ends conforming to PN10, 16 or 25 ratings of BS4504 or SABS 1123 Standards or ANSI B16.5 Class 150 or Class 300 Standards. Flanged ends shall be supplied with the requisite number of stainless steel screwed studs inserted for alignment to the specified standard. **Nuts and washers shall be excluded.**

OPERATION

1. Prior to the ingress of liquid into the valve chamber, as when the pipeline is being filled, valves shall vent through the large orifice when sewage/effluent approach velocities are relative to a transient pressure rise, on valve closure, of $< 1.5 \times$ valve rated pressure.

At higher sewage/effluent approach velocities, which have a potential to induce transient pressure rises $> 1.5 \times$ valve rated pressure on valve closure, the valve shall automatically discharge air/gas through the "Anti - Surge" Orifice and reduce sewage/effluent approach velocity, so that on closure a maximum transient pressure rise of $< 1.5 \times$ valve rated pressure is realised.

2. Valves shall not exhibit leaks or weeping of liquid past the large orifice seal at operating pressures of 0.5 bar (7.2 psi) to twice rated working pressure.

3. Valves shall prevent air from entering the pipeline by the seating of the upper chamber float in the upper chamber on the seat in the middle flange.

ORDERING GUIDE

<p>VALVE SIZE:</p> <p>DN50 (2") - <input type="text" value="050"/></p> <p>DN80 (3") - <input type="text" value="080"/></p> <p>DN100 (4") - <input type="text" value="100"/></p> <p>DN150 (6") - <input type="text" value="150"/></p> <p>DN200 (8") - <input type="text" value="200"/></p> <p>VALVE SERIES No.</p> <p>ANTI SHOCK ORIFICE:</p> <p>SPECIAL APPLICATION:</p> <p>BIAS AIR IN <input type="text" value="b"/></p> <p>BIAS AIR OUT <input type="text" value="v"/></p>	<p><input type="text" value="050"/> <input type="text" value="RG"/> <input type="text" value="X"/> <input type="text" value="v"/> <input type="text" value="10"/> <input type="text" value="2"/> <input type="text" value="1"/></p> <p>VALVE TYPE:</p> <p>DOUBLE ACTING <input type="text" value="1"/></p> <p>VALVE END CONNECTION:</p> <p>STUDED FLANGED - BS4504 or SABS 1123 <input type="text" value="0"/></p> <p>THREADED - BSP MALE <input type="text" value="1"/></p> <p>THREADED - NPT MALE <input type="text" value="2"/></p> <p>STUDED FLANGED - ANSI B16,5 <input type="text" value="3"/></p> <p>VALVE PRESSURE RATING:</p> <p>PN10 (145 psi) <input type="text" value="10"/></p> <p>PN16 (232 psi) <input type="text" value="16"/></p>
---	---

Note:

1. DN250 (10") and DN300 (12") valves are available on request.

All air release valves supplied shall be subjected to the following testing procedures in the order laid down:

- A) A high pressure strength and leak test whereby the valve is filled with water and pressurized to 1.5 x the rated working pressure which shall be held for a period of 2 minutes. Any leaking, weeping or sweating shall be reason for rejection.
- B) A low head leak test whereby the valve is filled with water and pressurized to a maximum of 0.5 bar (7.2 psi) using a visible water column connected to the test rig. The valve shall be rejected if leak tightness is not maintained for 2 minutes
- C) Every tenth air release valve of the same size and pressure rating must be subjected to a small orifice function test - "DROP TEST" - whereby the valve is filled with water, pressurized to above rated working pressure and isolated from the test rig by closure of an isolating valve. A chamber in the test rig immediately prior to the isolating valve must be filled with compressed air at a pressure equal to that being maintained in the air release valve. The isolating valve is then opened so as to allow the air to rise in the air release valve without the pressure dropping lower than 2 - 3 bar (29 - 44 psi) above rated working pressure of the air release valve. The "DROP TEST" is then carried out by slowly bleeding off the pressure through a suitable cock until rated working pressure is reached and the float drops away from the orifice to allow discharge. Failure of the air release valve to function in the manner described will be reason for rejection.

On request the manufacturer shall provide batch certificates of test compliance which shall be cross referenced to serial numbers indelibly marked onto the identity label of each valve.

IMPORTANT NOTE: It is impossible to inject air into an incompressible liquid, air injection can only be achieved if the liquid can be displaced which implies that the pressure in the test rig must be reduced to atmospheric, and absolutely nothing is proven by discharge through the small orifice of the air release valve at atmospheric pressure. "DROP TESTING" in this manner is not acceptable.

Complete the form below for any additional information and fax/post to:

Vent-O-Mat
P.O. Box 5064
Benoni South
South Africa
1502

Tel: (+27 11) 748 0200

Fax: (+27 11) 421 2749

E Mail: ventomat@dfc.co.za

Web site: www.ventomat.com

Company Name:

Postal Address:

Postal Code: Country:

Tel: Fax:

Contact Name: Title:

Comments:

.....
.....
.....

Products you are interested in:

VENT-O-MAT® Series RBXc Air Release & Vacuum Break Valves

compact cast single chamber design with integral "Anti-Shock" surge dampening mechanism in an economical cast ductile iron construction.

VENT-O-MAT® Series RBX Air Release & Vacuum Break Valves

compact Stainless Steel single chamber design with integral "Anti-Shock" surge dampening mechanism.

VENT-O-MAT® Series RC Air Release & Vacuum Break Valves

cast air valve for irrigation and small reticulation systems.

VENT-O-MAT® Series RPS Air Release & Vacuum Break Valves

glass reinforced polypropylene CATT air valve for industrial, irrigation and small reticulation systems.

LevelDex® High Performance Endline Level Control Valves

end line valve with cushioned closing characteristics for level control in tanks and reservoirs.