

# CARDEV®

Product Datasheet

## HDU-H8 By-pass Oil Filter

- Input pressure 2-6 Bar
- For systems up to 200 litres
- Up to 99.9% water removed (both free and dissolved water)
- Particle contamination (including combustion deposits) removed



### Benefits

- Removes microparticles including combustion deposits
- Removes free and dissolved water contamination
- Increases system reliability
- Prevents system corrosion
- Reduces component wear
- Extends oil life and generates CO<sub>2</sub> saving
- Reduces operating costs

### Application Examples

- Earth moving machines
- Forestry equipment
- Mobile cranes
- Drilling/piling equipment
- Static hydraulic systems

### Installation Example

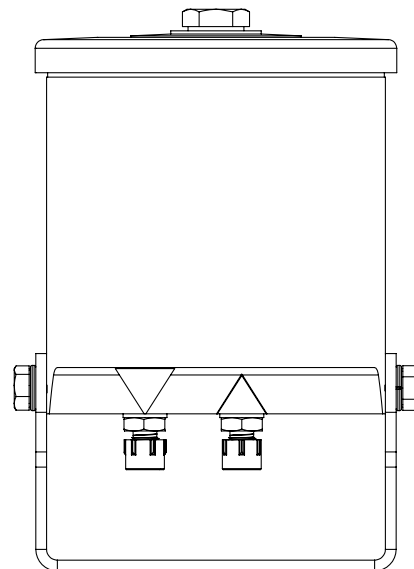
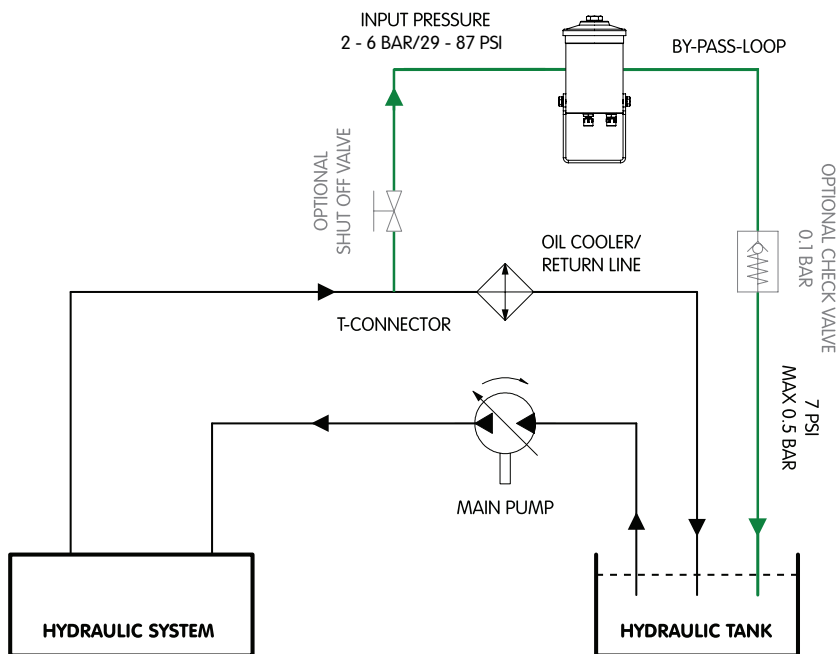

187.50mm

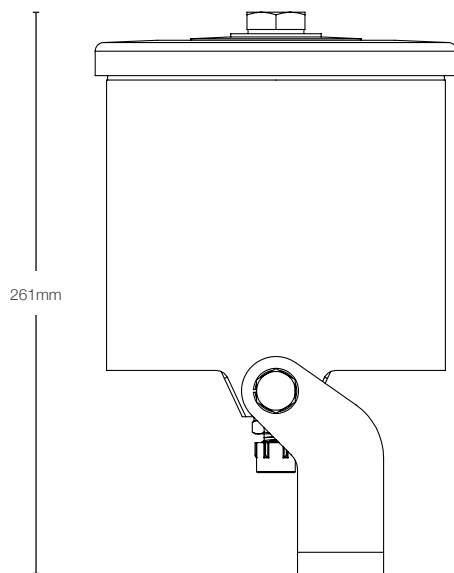

261mm

168mm

Recommended installation	Optimum Flow rate through filter (l/h)	Dimensions (mm)			Connections		Weight (kg)	Filter element	Retention capacity (per filter)	
		H	W	L	Inlet	Outlet			≤ 1 Dirt (kg)	≤ 0.37 Water (l)
BY-PASS ONLY. Max input pressure 2-6 Bar and 0.5 Bar back pressure. Systems up to 200 litres.	120	261	187.50	168	1/4" BSP (m)	1/4" BSP (m)	4.7	HDFC-N	≤ 1 Dirt (kg)	≤ 0.37 Water (l)



ETL Fluid Experts Ltd  
 Environmental Technologies Group Grimbald Crag Road Knaresborough North Yorkshire HG5 8PY United Kingdom  
 T +44 (0)1423 522911 F +44 (0)1423 530043 E sales@etf.com

[www.etfluidexperts.com](http://www.etfluidexperts.com)

The specification and photography is for reference only and may be subject to change. ETL Fluid Experts Ltd is part of the Environmental Technologies Group Ltd. All rights reserved.