

CARDEV[®]



Product Datasheet

LDU-H8 By-pass Oil Filter

- Input pressure 2-6 Bar
- Up to 99.9% water removed (both free and dissolved water)
- Particle contamination (including combustion deposits) removed

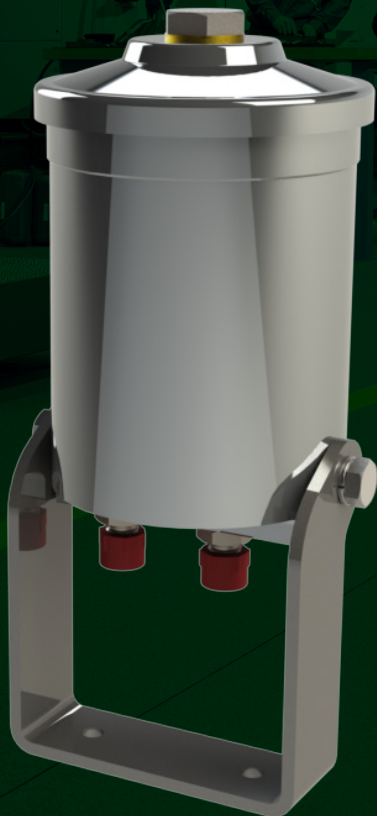

Benefits

- Removes microparticles including combustion deposits
- Removes free and dissolved water contamination
- Increases system reliability
- Prevents system corrosion
- Reduces component wear
- Extends oil life and generates CO₂ saving
- Reduces operating costs

Application Examples

- Earth moving machines
- Forestry equipment
- Mobile cranes
- Drilling/piling equipment
- Static hydraulic systems

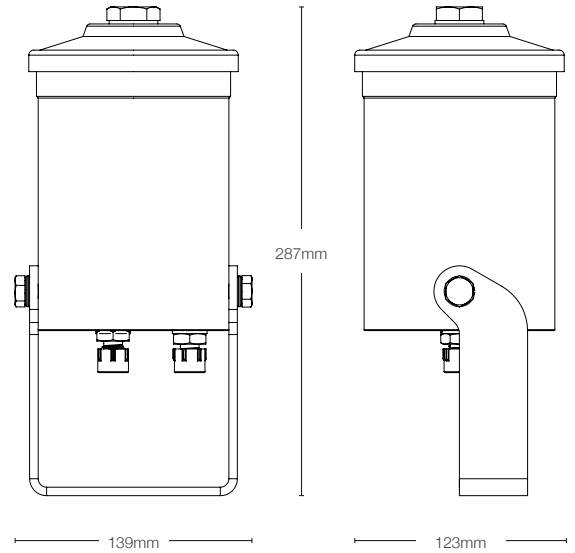

Installation Example

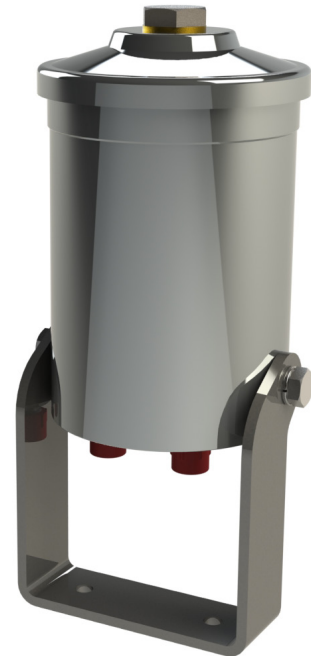
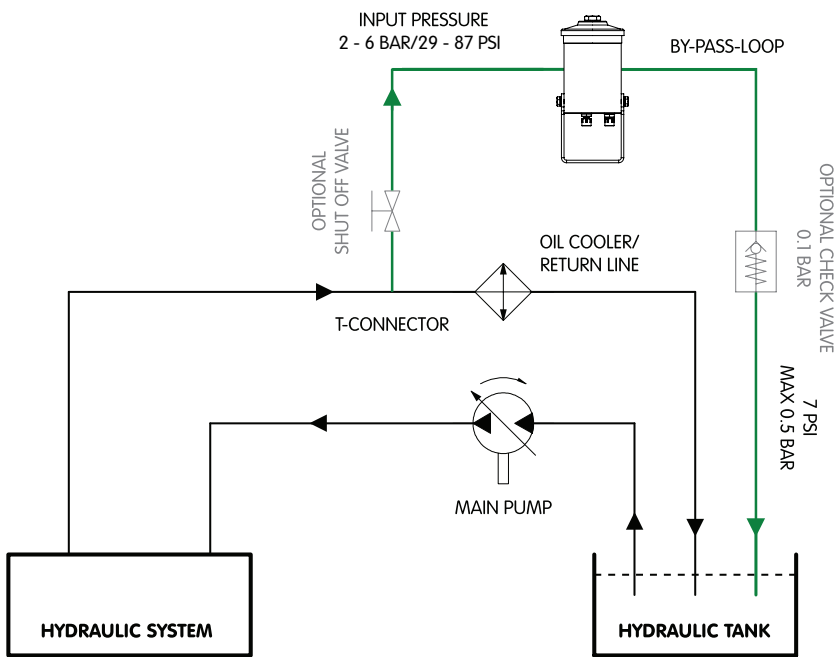

Recommended Installation	Flow rate through filter (l/h)	Dimensions (mm)			Connections		Weight (kg)	Filter element	Retention capacity (per filter)	
		H	W	L	Inlet	Outlet			≤ 0.6 Dirt (kg)	≤ 0.23 Water (l)
BY-PASS ONLY. Max input pressure 2-6 Bar and 0.5 Bar back pressure. Systems up to 100 litres.	70 (Max)	287	139	123	1/4" BSP (m)	1/4" BSP (m)	2.5	LDFC	≤ 0.6 Dirt (kg)	≤ 0.23 Water (l)

ETL FluidExperts

ETL Fluid Experts Ltd
 Environmental Technologies Group Grimbald Crag Road Knaresborough North Yorkshire HG5 8PY United Kingdom
 T +44 (0)1423 522911 F +44 (0)1423 530043 E sales@etfe.com

www.etfluidexperts.com

The specification and photography is for reference only and may be subject to change.
 ETL Fluid Experts Ltd is part of the Environmental Technologies Group Ltd. All rights reserved.