



ABSOLUTE ZERO LEAKAGE



OmniSeal® Double Block & Bleed Expanding Plug Valve

High integrity double block and bleed expanding plug valves for product isolation, blending, metering, custody transfer, fueling operations, terminal, storage and other land or offshore zero leakage applications.

- API 6D MONOGRAMMED
- HIGHEST QUALITY PLUG VALVES AT THE BEST POSSIBLE PRICE
- DELIVERED TO EXACTING CUSTOMER SPECIFICATIONS AND REQUIREMENTS
- ENGINEERED, ASSEMBLED AND TESTED FOR YEARS OF TROUBLE FREE SERVICE

Global Energy Market Solutions

OmniSeal® DB&B expanding plug valves are ideally suited for product isolation, refining, fueling, metering, terminal and storage applications.



OmniSeal® Introduction



OmniSeal® expanding plug valves are designed for applications where positive shut-off, verifiable zero leakage and double block and bleed (DB&B) and or double isolation and bleed (DIB) capabilities are required.

They are ideal for a variety of applications including leased automated custody transfer (LACT), product metering, aviation fueling, product isolation, blending, lockout/tagout (LOTO), multi-product manifolds, tank storage and other DB&B applications.

The OmniSeal® is a single valve solution that simultaneously blocks both the upstream and downstream flow while allowing the user to verify seal integrity using a manual or automatic body bleed system. It replaces older double block and bleed systems that use two valves with a spool and bleed valve in-between. OmniSeal® valves have exclusive features designed for better performance throughout the valve's lifetime.

All OmniSeal® DB&B expanding plug valves are manufactured and monogrammed per API 6D and ISO 9001, fire tested per API 607 and API 6FA and have specific certifications such as CE/PED, CRN (Canadian Registration), TA-Luft or similar design or regional certifications where appropriate.

OmniSeal® DB&B expanding plug valves have been determined to be a "Product of the USA " by the US Customs and Border Protection Agency (CBP). This applies to both commercial and US government or military procurement.

TABLE OF CONTENTS

Introduction	3
Applications	4
Single Valve DB&B Solutions	5
Typical Valve Configuration	6
Size Range & Materials of Construction	7
Valve Operations	8
Design Features	10
Relief Systems	12
Dimension Tables	14
Torque & Turns Charts / Automation	18
Motor Adaptation Kits	19
Standard Operator / DTR Configurations	20
Limit Switch Assemblies	22
Position Indicators and Locking Mechanisms	23
Stem Extensions	24
Replacement Parts and Rebuild Kits	25
Figure Numbers	26
Manufacturer, Sales, Service & Distribution, Product Warranty	27

Applications

OmniSeal® expanding plug valves are ideal for applications that require positive shut-off, verifiable zero leakage and double block and bleed (DB&B) and or double isolation and bleed (DIB) capability. Some of the more common applications include:

BLENDING UNITS: Accurate blending of ethanol or other regional fuel grades requires valves with exceptionally high seal integrity to ensure accurate measurement of additives and blending stocks. The OmniSeal® DB&B is specifically designed for these type of applications.

PRODUCT ISOLATION: Secure isolation of biofuels or other process-sensitive fluids is critical for environmental and process safety. The OmniSeal® DB&B's verifiable zero leakage and positive shutoff capabilities make it an ideal solution for isolation and process-sensitive applications.

MULTI-PRODUCT MANIFOLDS: Pipeline, refinery and transfer manifolds need to flow multiple products (e.g. diesel, jet fuel, gasoline, blending stocks, etc.) reliably and without contamination. The OmniSeal® DB&B is an effective tool for preventing product cross-contamination.

PROVER LOOPS: Proper calibration of flow meters requires that every valve in the prover loop system must have a zero leak rate. Any leak could mean an error in calibration. OmniSeal® DB&B valves are used to ensure leak tight closure and accurate calibration.

CUSTODY TRANSFER UNITS: Transfer of valuable media relies on accurate measurement of product transfer quantity. The OmniSeal® DB&B provides positive shutoff and zero leak rate, thereby ensuring the accuracy of transfer quantity calculations.

OFFSHORE PLATFORMS: Valve leakage on an offshore platform can result in damage to equipment and the environment. The OmniSeal® DB&B has excellent low pressure positive shutoff characteristics and is a great choice for use on offshore platforms.

TERMINALS: Terminals used for loading and unloading tankers require valves with positive sealing in order to prevent environmental damage due to spillage. The OmniSeal® DB&B provides positive sealing and zero leak rate in a reliable single valve solution.

TANK FARMS (OIL DEPOTS): Tank isolation valves, which are operated frequently, require zero leak rate and a high degree of reliability. The OmniSeal® DB&B valve provides a reliable, high integrity seal designed for frequent and long-term use.

AVIATION FUELING SYSTEMS: Airport fueling systems require valves that close quickly and have verifiable seal integrity. This allows for quick maintenance, repair, leak location and testing. The OmniSeal® DB&B valve's verifiable zero leak rate ensures that maintenance, repair, leak location and hydrant testing can be done safely and quickly. OmniSeal® DB&B expanding plug valves have been determined to be a "Product of the USA " by the US Customs and Border Protection Agency (CBP). This applies to both commercial and US government or military procurement.

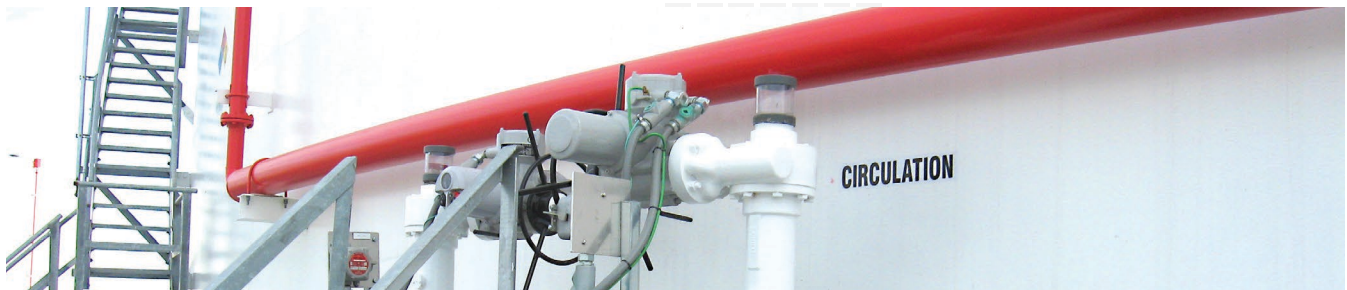

Single Valve / Double Block & Bleed Solution



The OmniSeal® replaces antiquated two-valve systems with a single DB&B valve solution. The OmniSeal® has two seats (slips) and provides a bubble tight seal.

Older double block & bleed systems (as shown below) use two valves and a spool piece with a bleed valve used to drain the spool and verify seal integrity.

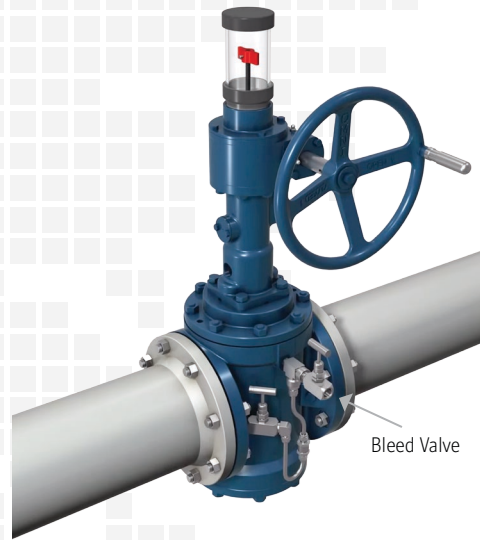
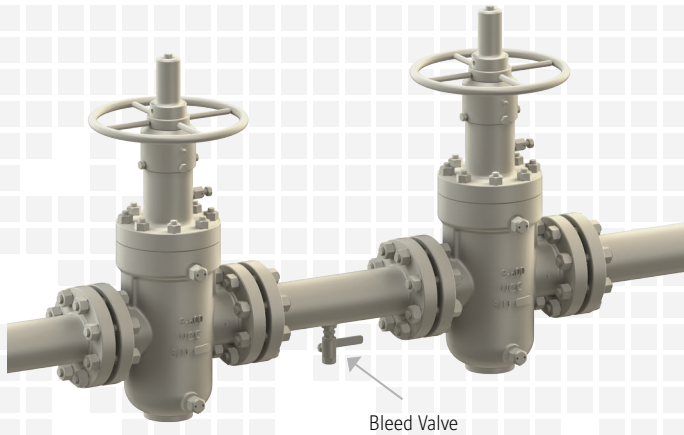

1. The OmniSeal® upstream and downstream slip seals provide the same function as the two block valves shown above.

2. The OmniSeal® body (serving as the spool piece shown above) bleeds to verify seal integrity.

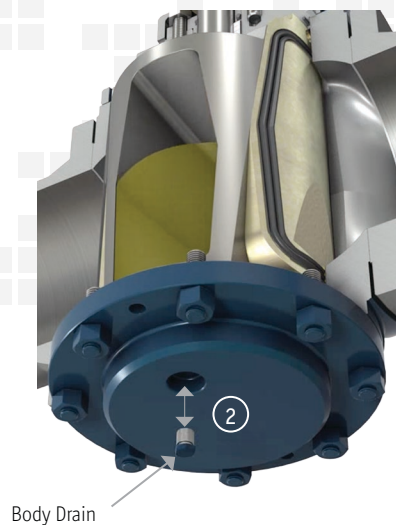

OmniSeal® Typical Valve Configuration

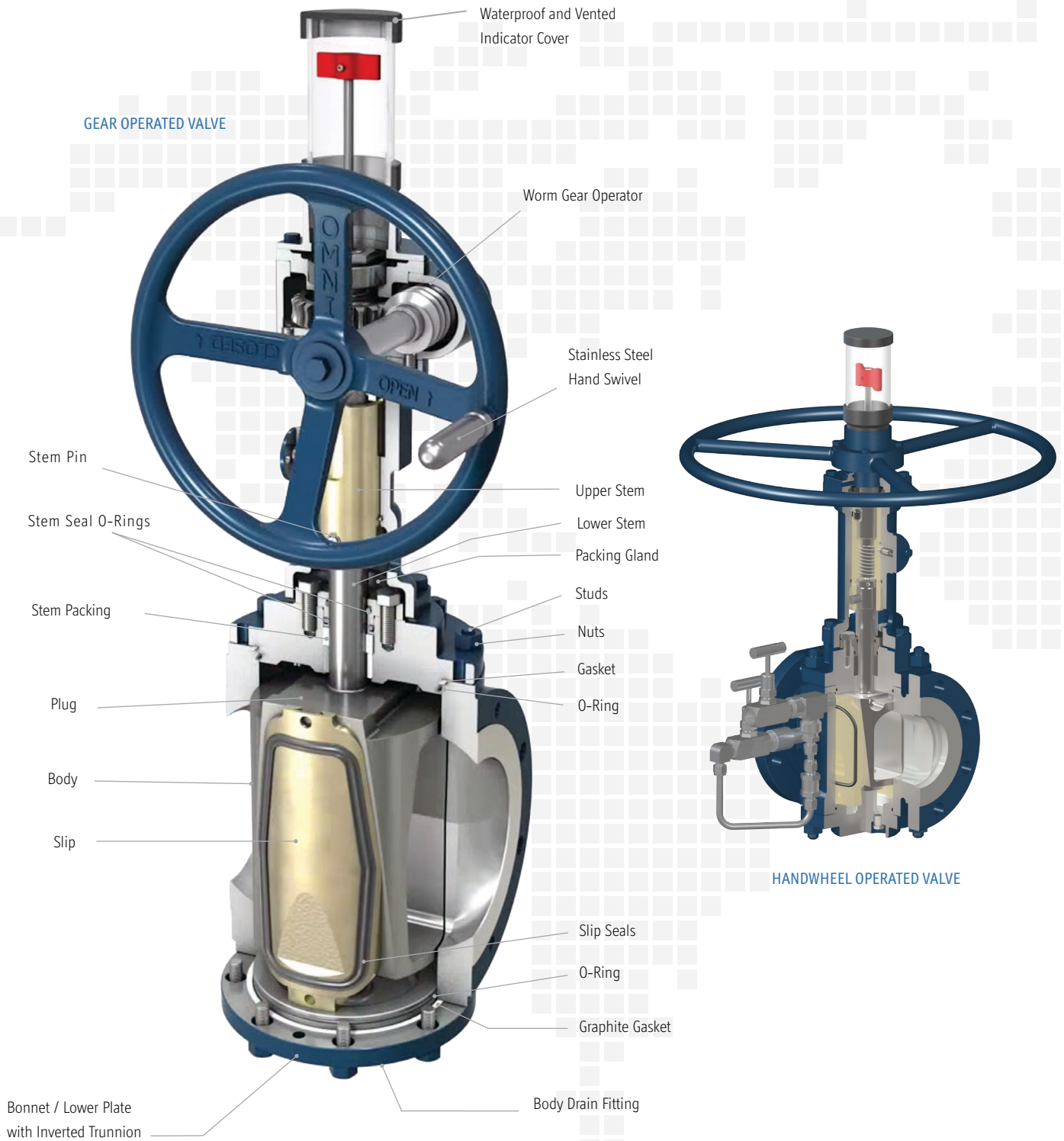

Size Range & Materials of Construction



AVAILABLE SIZES AND PRESSURES

ANSI CLASS	Sizes (inches)															
	2	3	4	6	8	10	12	14	16	18	20	24	26	28	30	36
150	HW/GO	HW/GO	HW/GO	HW/GO	GO*	GO*	GO*	GO*	GO*	GO*	GO*	GO*	GO*	GO*	GO*	GO*
300	HW/GO	HW/GO	HW/GO	GO*	GO*	GO*	GO*	GO*	GO*	GO*	GO*	GO*	GO*	GO*	GO*	N/A
600	HW/GO	HW/GO	GO	GO*	GO*	GO*	GO*	GO*	GO*	GO*	GO*	GO*	GO*	GO*	GO*	GO*

HW = Available Only as Handwheel Operated

* These sizes have lifting lugs

GO = Available Only as Gear Operated

HW/GO = Available as Handwheel or Gear Operated

STANDARD MATERIALS OF CONSTRUCTION (ALTERNATIVE MATERIALS AVAILABLE UPON CUSTOMER REQUEST)

All OmniSeal® plug valves are constructed to meet requirements of NACE MR0175 / ISO 15156

Component	Standard Temp. (-20° to 400° F) (-29° to 204° C)	Low Temp. (-40° to 400° F) (-40° to 204° C) ⁽¹⁾
Body	Cast ASTM A216 WCC ⁽²⁾	Cast ASTM A352 LCC ⁽²⁾
Bonnet/ Lower Plate	Cast ASTM A216 WCC / Forged ASTM A350 LF6 CL2	Cast ASTM A352 LCC / Forged ASTM A350 LF6 CL2
Plug and Stem	Cast ASTM A216 WCC ⁽³⁾	Cast ASTM A352 LCC ⁽³⁾
Slips	Cast Ductile Iron / Cast A395 GR 60-40-18	Cast ASTM A352 LCC
Packing Gland	Forged ASTM A350 Gr. LF2	Forged ASTM A350 Gr. LF2
Stem Packing	Pre-Formed Flexible Graphite	Pre-Formed Flexible Graphite
Gasket	Pre-Formed Flexible Graphite	Pre-Formed Flexible Graphite
O-Rings & Slip Seals	Viton B ⁽⁴⁾	Viton GFLT ⁽⁴⁾
Bonnet to Body Studs	ASTM A193 Gr. B7M	ASTM A320 Gr. L7M
Bonnet Nuts	ASTM A194 Gr. 2HM	ASTM A194 Gr. 2HM
Relief System Tubing	AISI 316 SS / AISI 304 SS	AISI 316 SS / AISI 304 SS
Relief System Needle Valve	AISI 316 SS	AISI 316 SS
Relief System Check Valve	AISI 316 SS	AISI 316 SS

- Notes:**
- (1) -40°F is the minimum temperature rating using our standard materials of construction however lower temperature ratings are available to meet customer requirements.
 - (2) Electroless Nickel Plated - Entire Internal Surface
 - (3) Electroless Nickel Plated - Entire Component
 - (4) All OmniSeal® valves in class 300 & 600 are supplied with double reinforced Viton seals.

OPTIONAL MATERIALS OF CONSTRUCTION & OTHER CUSTOMIZED FEATURES

OmniSeal® DB&B Expanding Plug Valves are available in a variety of configurations and material of construction depending on customer preferences, specifications, severe temp ranges and / or service conditions.

Common valve options include:

- Flanges drilled to DIN or other regional standards, or constructed with face to face dimensions specific to particular projects
- Subjected to more rigorous customer-specified extended testing regimes
- Special coating applications based on customer specifications, service conditions or cosmetic preferences
- Constructed to withstand extreme high or low temperatures - Please consult factory
- Customer specified limit switches or other accessories
- Special Automatic Body Bleed Valve (ABBV) or customer specific relief systems

Valve Operation

FULL OPEN POSITION



In the fully open position, the resilient seals are positioned out of the flow path and protected within the body of the valve itself.



PARTIALLY CLOSED POSITION



As the valve is cycled from the fully open to closed position, the plug begins a 90 degree rotation. During the entire rotation of the plug the resilient seals located on both slips are retracted away from the body. This ensures no rubbing or scraping action during rotation of the plug from the open to the closed position.



Valve Operation



CLOSED POSITION PRIOR TO SEALING

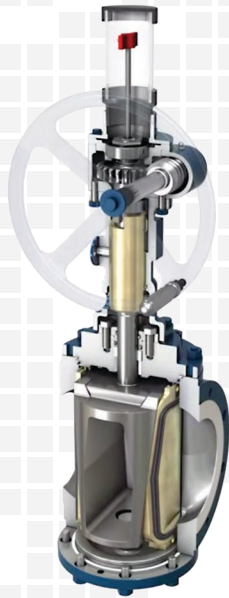

After the plug has been rotated 90 degrees from the fully open to fully closed position, the resilient seals on both slips have not yet been forced outward and into the seating position. This expansion only occurs with continued rotation of the handwheel or actuator.

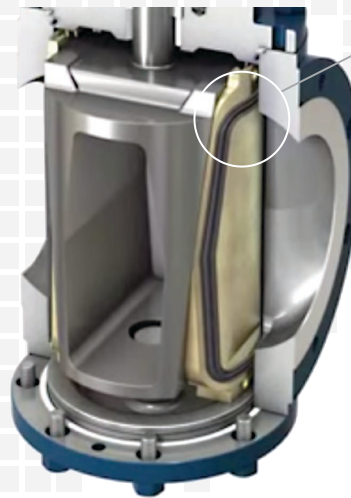

With continued rotation of the handwheel, this small gap between the slip seal and the valve body is closed by the slip moving in the outward direction. Once the slip seal is firmly seated against the valve body sealing surface, the valve achieves a positive, zero-leakage seal.

FULLY CLOSED (SEALED) POSITION

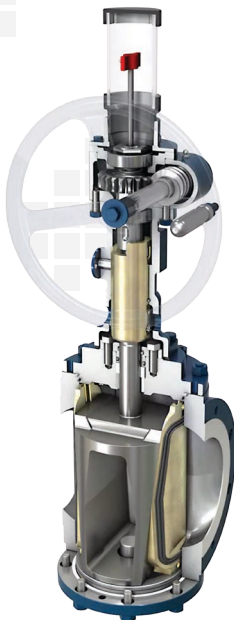

To fully close the valve and provide positive shut-off, the slips are expanded outward with continued rotation of the handwheel or actuator. This outward expansion is achieved by the tapered plug moving downward which causes the slip seals to seal against the valve body.



Design Features

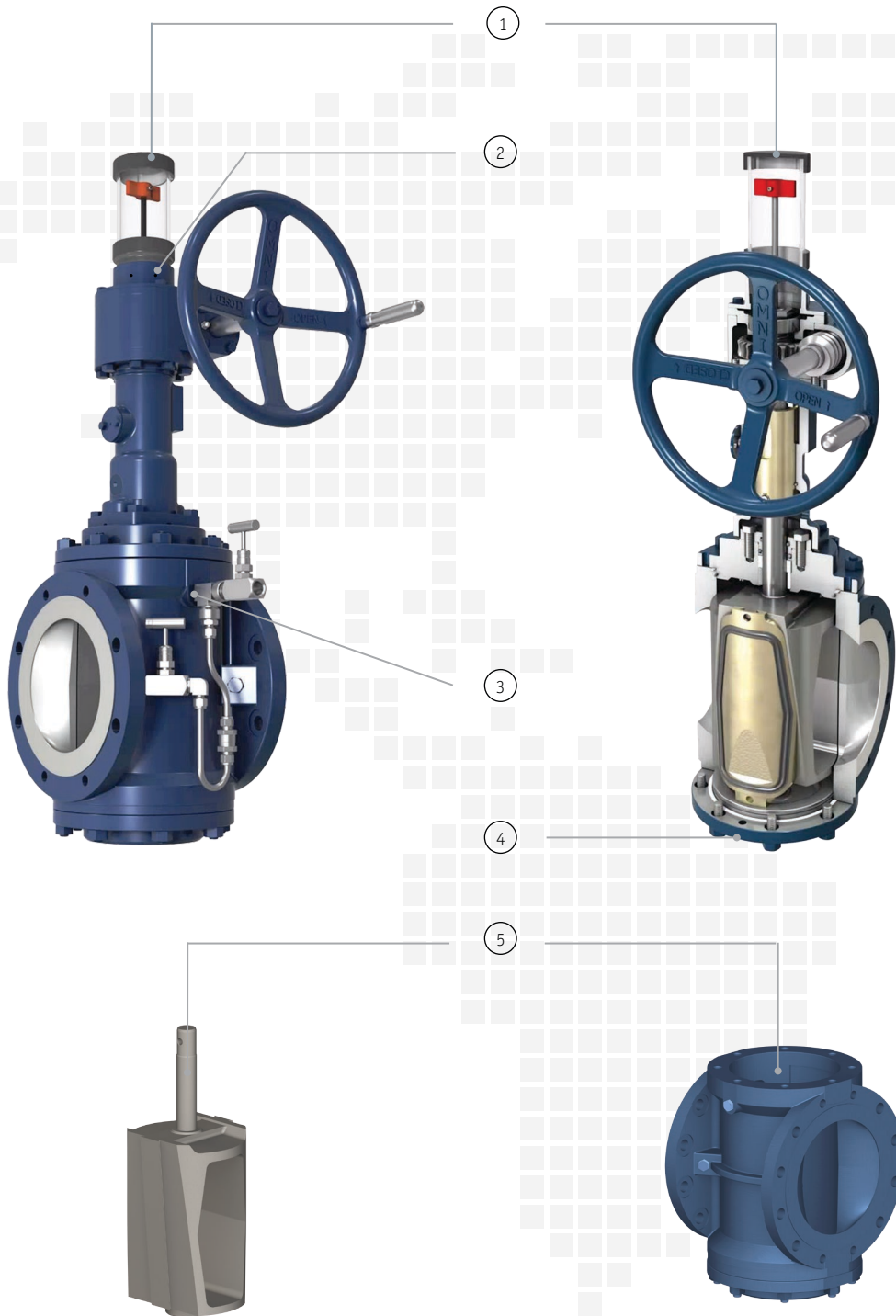

OmniSeal® DB&B expanding plug valve exclusive design features:

1. POLYCARBONATE PROTECTOR CAP

OmniSeal® DB&B expanding plug valve has a robust polycarbonate indicator flag protector. This keeps moisture and debris from infiltrating the operator housing. The top of the indicator cap (shown below) is vented to ensure that air flow will quickly evaporate any condensation that appears inside the clear housing.

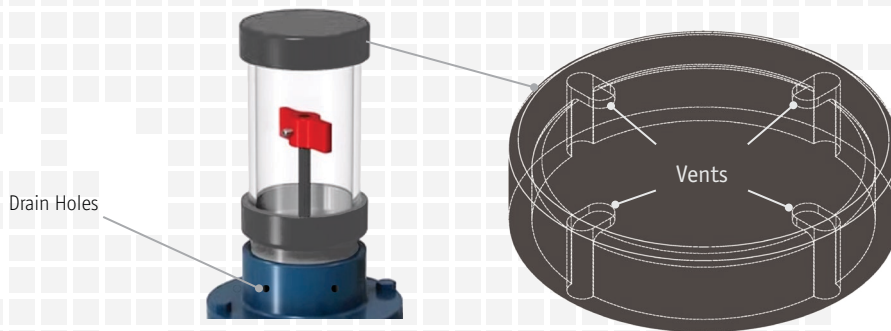

2. DRAIN HOLES

The upper adapter is blanked off underneath the protector cap. It features one penetration sealed with an o-ring for the indicator shaft. This prevents moisture ingress into the gearbox in the event that the indicator protector is removed or damaged. Drain holes in the adapter allow evacuation of any moisture/ condensation that may be in the area.

3. LOCATION OF RELIEF SYSTEM PORT

Some competitive DB&B plug valve offerings have the top port for the relief system located on the upper bonnet. Therefore, the relief system must be disconnected whenever the upper bonnet needs to be removed for maintenance or repair. The OmniSeal® port is located on the upper section of the valve body. This eliminates any need to disassemble the relief system in order to remove the valve bonnet.

4. LOWER TRUNNION DESIGN

The lower trunnion of the OmniSeal® valve is an integral part of the lower bonnet and is **NOT** part of the plug. There is no cavity present in the bottom of the valve body to collect dirt, scale, ice or other debris that could make the valve hard to turn or otherwise interfere with valve function.

5. SURFACE TREATMENT OF BODY CAVITY AND PLUG

The interior cavity of the valve body and the entire plug are plated with electroless nickel to ensure a corrosion-free sealing surface for slip seals.

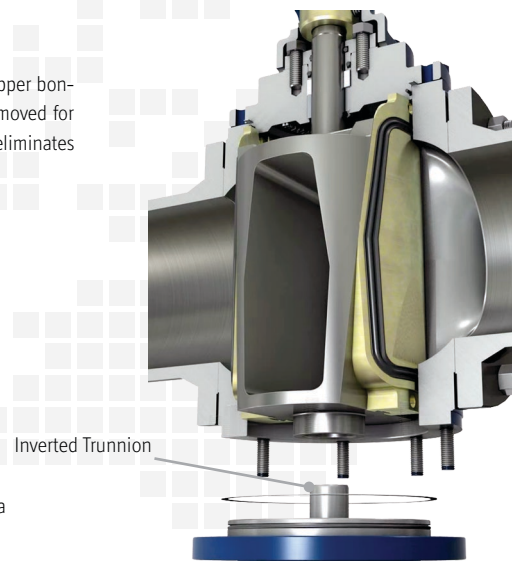

Relief Systems

Excess pressure is normally the result of thermal expansion of the fluid and gases trapped inside the valve body. The trapped media is relieved to the upstream side when the pressure inside the valve body is 25 psi (in a standard check valve) greater than the pressure in the upstream piping. The 25 psi spring can be changed in the check valve. Available pressures range from 1 psi to 100 psi.

OmniSeal® valves have a 100% zero verifiable leakage guarantee. This means that any leaks that get past the upstream slip seal will be indicated through the bleed to atmosphere valve before they are able to leak past the downstream slip seal. This prevents any costly contamination to other products caused by undetected leakage.

In order for the automatic relief system to function properly, the valve that controls the upstream relief must be kept open and the valve that controls the manual bleed to atmosphere must be kept closed. Unless otherwise specified by the customer all systems include an upstream isolation valve to allow servicing of the DTR without draining the upstream line. This isolation valve also aides in troubleshooting the plug valve and its relief system.



MANUAL BLEED WITH THERMAL RELIEF TO UPSTREAM - (STANDARD)

The standard relief system offered on the OmniSeal® valve is designed to relieve excess pressure in the valve cavity due to thermal expansion when the valve is in the closed position. The system also features a manual bleed to atmosphere.



MANUAL BLEED WITH THERMAL RELIEF TO UPSTREAM - WITH GAUGE

This system functions the same as the standard system with the addition of a pressure gauge piped into the body cavity. This allows a visual indication of pressure present in the valve body without exposing the body cavity to the atmosphere. The figure also shows an additional plugged NPT port as specified by the customer. The additional port can be added to any DTR configuration as requested by the customer.



COLD CLIMATE

This configuration is similar to the standard DTR configuration. The only difference is that the piping and check valve are in an orientation that prevents fluids from settling in the piping. This is done to prevent moisture from accumulating in the DTR system and freezing which would cause damage to the system. The orientation shown is the most effective method when the valve is installed in the upright position. The customer must specify in which orientation the valve will be installed so that the piping can be configured to function properly.



MANUAL RELIEF TO ATMOSPHERE, THERMAL RELIEF FROM DOWNSTREAM AND BODY TO UPSTREAM

This configuration contains automatic bleed to upstream with a manual bleed to atmosphere. In addition to the body bleed to upstream there is an automatic bleed from the downstream side of valve to the upstream side of valve. This keeps the pressure created by thermal expansion in the downstream piping to a minimum. There are isolation valves on the upstream side and the downstream side of the valve to enable servicing of the DTR system without removing the entire valve from service.



UPSTREAM VENT FULL ISOLATION

This ADTR system contains automatic bleed to upstream with a manual bleed to atmosphere. There is an isolation valve on the upstream side of the valve as well as on the body side of the valve to enable servicing of the ADTR system without removing the entire valve from service. Additionally there is a bleed to atmosphere located on the upstream side of the valve that allows the operator to vent the pressure from the upstream side of the valve without opening the valve.



CUSTOMER-SPECIFIED RELIEF SYSTEMS

All ADTR systems can be configured with customer specified components and designs. The one shown in the figure is built using locking ball valves, however any valve design and manufacture can be used including, but not limited to, ball valves, needle valves, and gate valves. [Please contact Omni Valve for more details.](#)

Dimension Tables

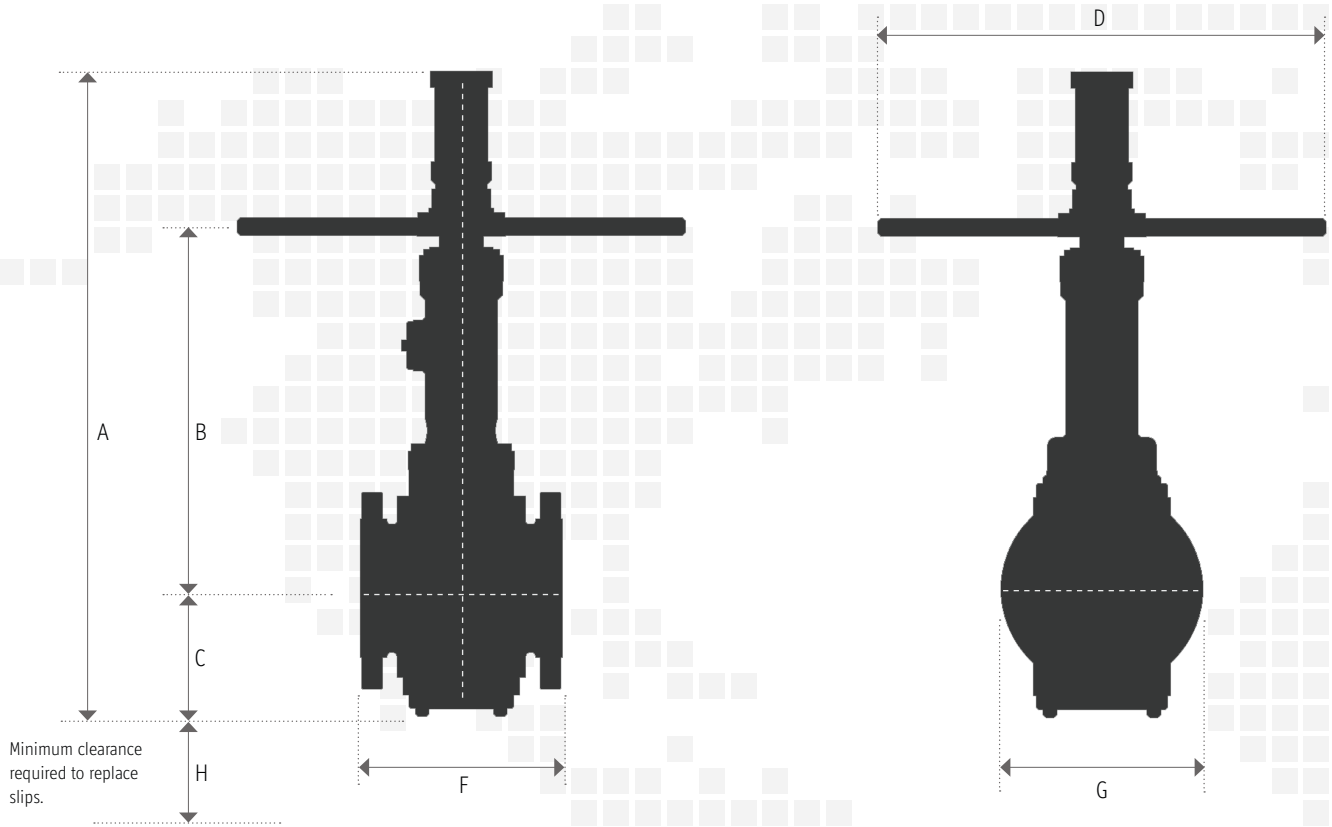

Class	Size	Oper.	A		B		C		D		F		G		H		Weight		(Number) & Size Tapped Holes Each Flange	CV (Gpm)
			in.	mm	in.	mm	in.	mm	in.	mm	in.	mm	in.	mm	in.	mm	lbs	kgs		
150	2	37H	18.0	457	10.6	269	4.0	102	10	254	7	178	6	152	3	76	46	21	none	Contact Factory for CV Data
	3	37H	18.0	457	10.6	269	4.0	102	10	254	8	203	7.5	191	3	76	59	27	none	
	4	50H	27.5	699	16.0	406	6.0	152	20	508	9	229	9	229	4.5	114	132	60	none	
	6	50H	32.6	828	18.0	457	7.5	191	20	508	10.5	267	11	279	8	203	196	89	(4) 3/4"-10 UNC	
300	2	37H	18.0	457	10.6	269	4.0	102	10	254	8.5	216	6.5	165	3	76	52	24	none	
	3	37H	18.0	457	10.6	269	4.0	102	10	254	11.1	282	8.25	210	3	76	73	33	none	
	4	50H	28.3	719	16.0	406	5.5	140	20	508	12	305	10	254	5	127	158	72	none	
600	2	50H	26.0	660	15.5	394	4.0	102	20	508	11.5	292	6.5	165	2.5	64	100	45	none	
	3	50H	26.0	660	16.0	406	5.0	127	20	508	14	356	8.3	211	3.5	89	142	64	none	

Dimension Tables

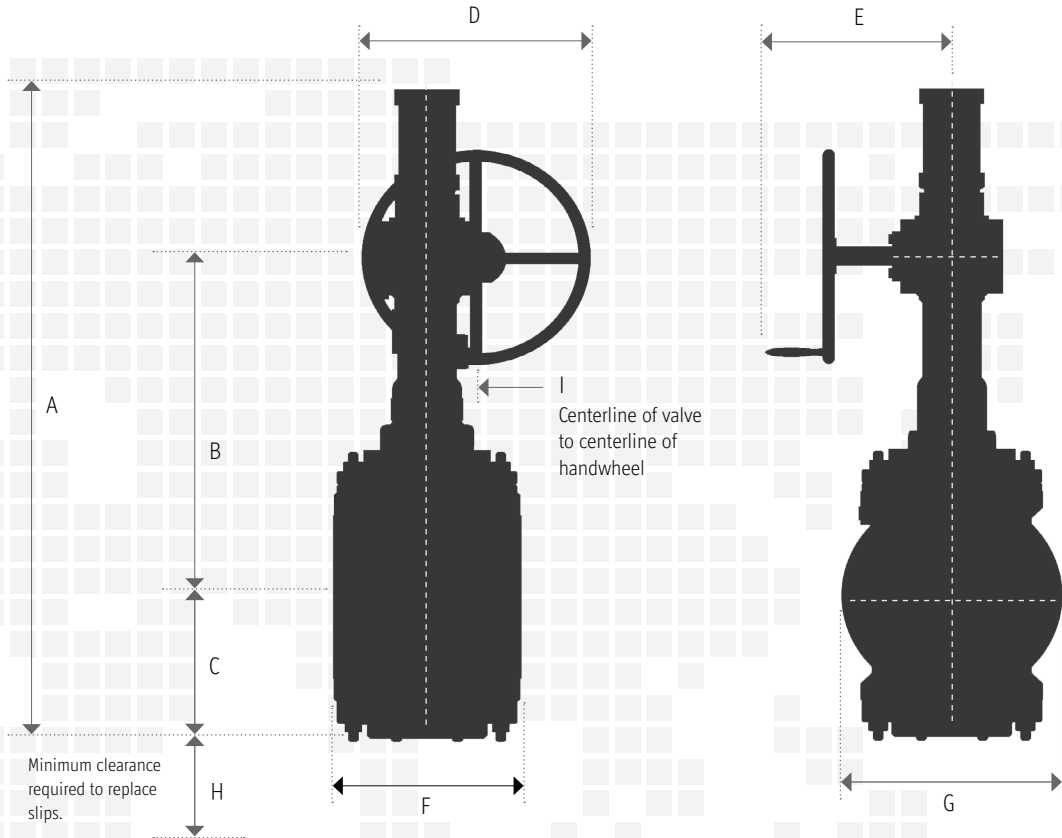

Class	Size	Oper.	A		B		C		D		E		F		G		H		I		Weight		(Number) & Size Tapped Holes Each Flange	CV (Gpm)
			in.	mm	in.	mm	in.	mm	in.	mm	in.	mm	in.	mm	in.	mm	in.	mm	in.	mm	lbs	kgs		
150	2	37G	22.8	579	11.9	302	4.0	102	10	254	12.4	315	7	178	6	152	3	76	1.8	44	69	31	none	Contact Factory for CV Data
	3	37G	22.8	579	11.9	302	4.0	102	10	254	12.4	315	8	203	7.5	191	3	76	1.8	44	78	35	none	
	4	55G	30.0	762	16.1	409	6.0	152	10	254	14.7	373	9	229	9	229	4.5	114	2.4	61	118	54	none	
	6	55G	34.6	879	18.3	465	7.5	191	10	254	14.4	366	10.5	267	11	279	10	254	2.4	61	180	82	(4) 3/4"-10 UNC	
	8	62G	42.5	1080	22.0	559	9.2	234	14	356	14.7	373	11.5	292	13.5	343	14	356	3	76	314	143	(4) 3/4"-10 UNC	
	10	62G	46.0	1168	24.0	610	11.0	279	14	356	14.7	373	13	330	16	406	16	406	3	76	483	220	(4) 7/8"-9 UNC	
	12	75G	55.0	1397	31.0	787	12.5	318	20	508	14.7	373	14	356	19	483	26	660	3.5	89	719	327	(4) 7/8"-9 UNC	
	14	75G	58.0	1473	32.5	826	14.3	363	20	508	14.7	373	15	381	21	533	28	711	3.5	89	938	426	(4) 1.0"-8 UNC	
	16	12G	65.0	1651	39.0	991	16.0	406	20	508	17.5	445	16	406	23.5	597	30	762	5	127	1225	557	(8) 1.0"-8 UNC	
	16V	75G	58.0	1473	32.5	826	14.3	363	20	508	14.7	373	16	406	23.5	597	28	711	3.5	89	1110	503	(8) 1.0"-8 UNC	
	18	12G	60.0	1524	36.0	914	14.0	356	20	508	17.5	445	34	864	25	635	30	762	5	127	2658	1206	none	
	18V	12G	64.9	1648	38.7	983	16.0	406	20	508	17.5	445	17	432	25	635	30	762	5	127	1319	600	(8) 1 1/8"-8 UNC	
	20	12G	63.0	1600	37.0	940	15.3	389	20	508	17.5	445	40	1016	27.5	699	27	686	5	127	3306	1500	none	
	20V	12G	69.5	1765	40.3	1024	18.6	472	20	508	17.5	445	32	813	27.5	699	32	813	5	127	2780	1264	(4) 1 1/8"-8 UNC	
	24	12G	75.0	1905	44.0	1118	21.0	533	20	508	17.5	445	48	1219	32	813	32	813	5	127	6264	2841	none	
	24V	12G	77.9	1979	45.6	1158	21.8	554	20	508	17.5	445	36	914	32	813	37	940	5	127	4682	2128	(8) 1 1/4"-8 UNC	
	26	14G	99.0	2515	56.7	1441	29.5	748	32	813	26	660	42	1067	34.3	870	38	965	9	229	8736	3971	(16) 1 1/4"-8 UNC	
	28	14G	99.0	2515	56.7	1441	29.5	748	32	813	26	660	42	1067	36.4	925	38	965	9	229	9049	4113	(12) 1 1/4"-8 UNC	
30	15G	97.3	2471	75.2	1910	27.4	696	32	813	26	660	60	1524	38.8	986	41	1041	9	229	15568	7076	(12) 1 1/4"-8 UNC		
36	15G	119.2	3028	76.0	1930	30.0	762	32	813	26	660	78	1981	46	1168	41	1041	9	229	22008	10004	none		

(V) Designates a valve with a reduced face-to-face dimension versus the Omni standard pattern, except for the 16V

Dimension Tables

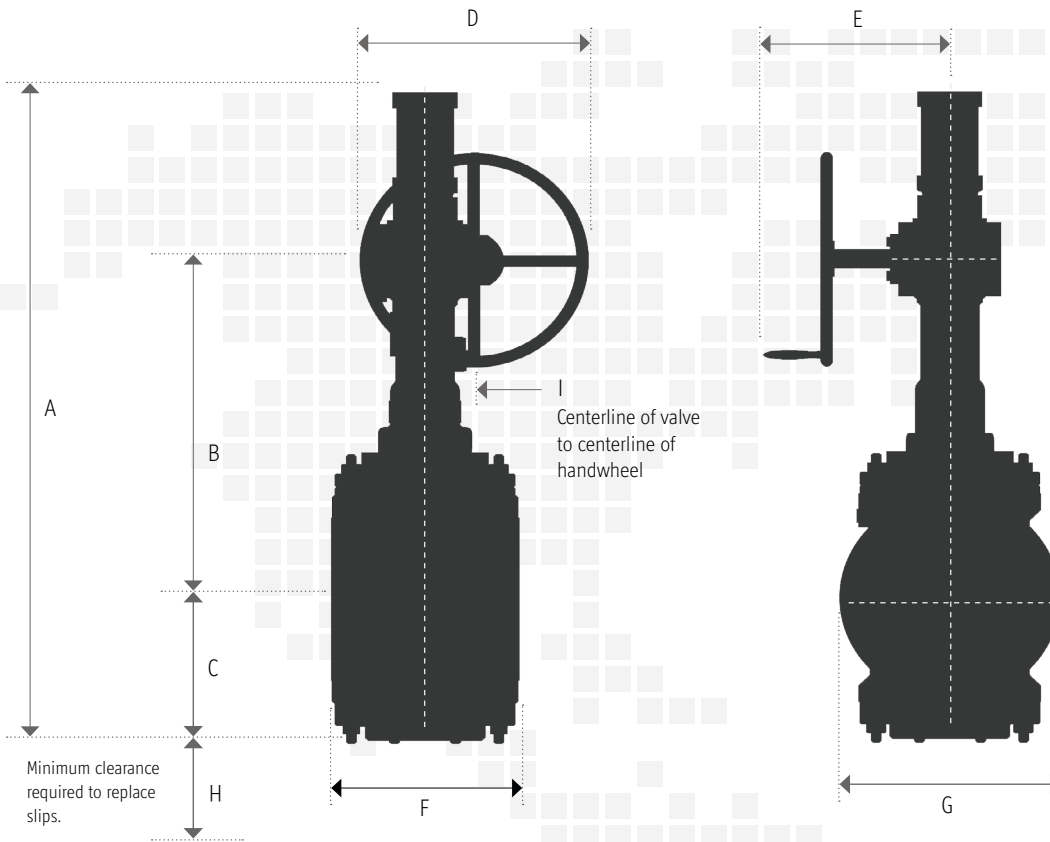

Class	Size	Oper.	A		B		C		D		E		F		G		H		I		Weight		(Number) & Size Tapped Holes Each Flange	CV (Gpm)
			in.	mm	in.	mm	in.	mm	in.	mm	in.	mm	in.	mm	in.	mm	in.	mm	in.	mm	Lbs	Kgs		
300	2	37G	22.8	579	11.9	302	4.0	102	10	254	12.4	315	8.5	216	6.5	165	3	76	1.8	46	74	34	none	Contact Factory for CV Data
	3	37G	22.8	579	11.9	302	4.0	102	10	254	12.4	315	11.1	282	8.3	211	3	76	1.8	46	90	41	none	
	4	55G	30.0	762	16.2	411	5.5	140	10	254	14.7	373	12	305	10	254	5	127	2.4	61	142	65	none	
	6	62G	39.0	991	20.5	521	7.7	196	14	356	14.7	373	15.9	404	12.5	318	10	254	3	76	209	95	none	
	8	75G	49.0	1245	28.0	711	9.5	241	20	508	14.7	373	16.5	419	15	381	14	356	3.5	89	571	260	(4) 7/8" -8 UNC	
	10	75G	51.8	1316	29.0	737	11.0	279	20	508	14.7	373	18	457	17.5	445	16	406	3.5	89	700	318	(4) 1.0" -8 UNC	
	12	12G	61.0	1549	36.5	927	14.0	356	20	508	17.5	445	19.8	503	20.5	521	26	660	5	127	1383	629	(8) 1-1/8" -8 UNC	
	14	12G	60.9	1547	36.8	935	13.7	348	20	508	17.5	445	30	762	23	584	26	660	5	127	1470	668	none	
	16	12G	60.3	1532	36.5	927	13.5	343	20	508	17.5	445	33	838	25.5	648	23	584	5	127	2651	1205	none	
	16F	14G	81.4	2066	49.6	1260	18.9	481	32	813	26	660	35	889	25.5	648	27	686	9	229	5521	2504	(8) 1-1/4" -8 UNC	
	18	12G	71.0	1803	40.5	1029	17.0	432	20	508	17.5	445	36	914	28	711	26	660	5	127	3984	1811	(12) 1-1/4" -8 UNC	
	20	14G	81.4	2068	48.0	1219	20.0	508	32	813	26	660	39	991	30.5	775	29	737	9	229	5802	2637	(12) 1-1/4" -8 UNC	
	24	14G	91.3	2319	54.1	1373	24.5	621	32	813	26	660	45	1143	36	914	38	965	9	229	7883	3583	none	
	30	15G	120.0	3048	71.0	1803	32.5	826	32	813	26	660	65	1651	43	1092	41	1041	9	229	21000	9545	none	

Dimension Tables

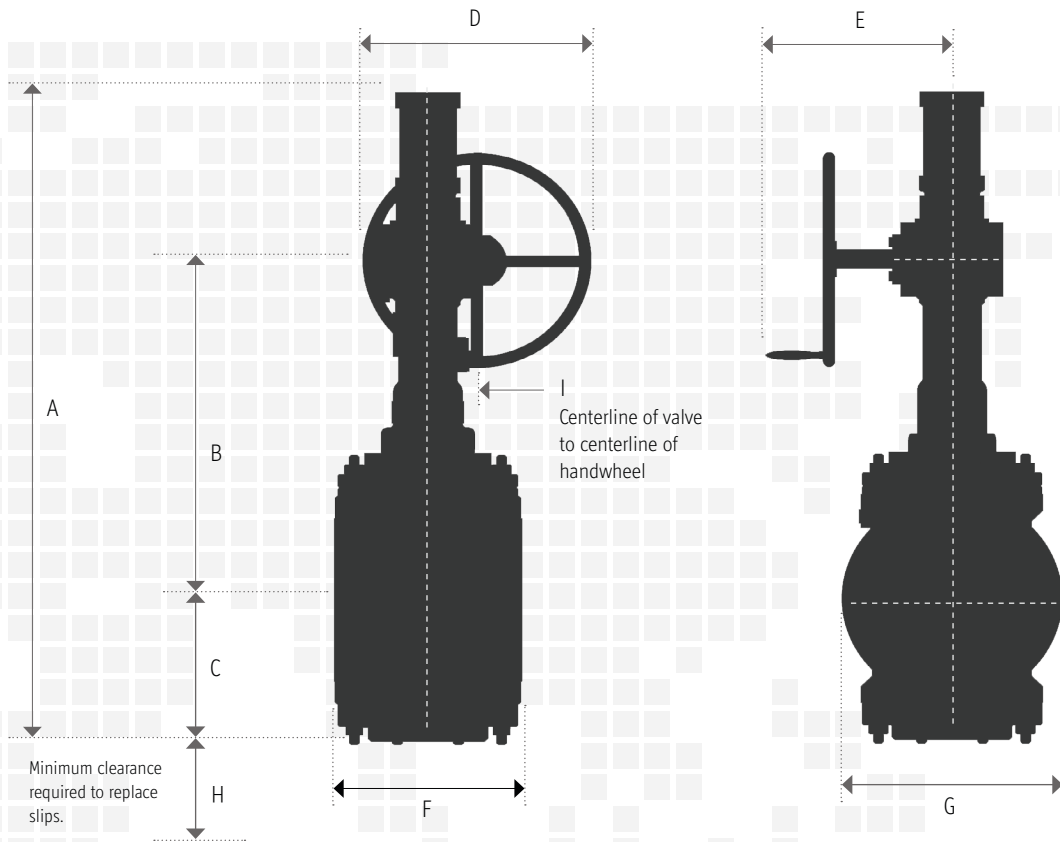

Class	Size	Oper.	A		B		C		D		E		F		G		H		I		Weight		(Number) & Size Tapped Holes Each Flange	CV (Gpm)
			in.	mm	in.	mm	in.	mm	in.	mm	in.	mm	in.	mm	in.	mm	in.	mm	in.	mm	Lbs	Kgs		
600	2	55G	28.0	711	15.5	394	4.0	102	10	254	14.5	368	11.5	292	6.5	165	2.5	64	2.4	61	116	23	none	Contact Factory for CV Data
	3	55G	29.0	737	16.0	406	5.0	127	10	254	14.5	368	14	356	8.3	211	3.5	89	2.4	61	129	59	none	
	4	62G	36.0	914	19.0	483	6.2	157	14	356	14.7	373	17	432	10.8	274	3.5	89	3	76	195	89	none	
	6	75G	45.6	1158	26.0	660	8.0	203	20	508	14.7	373	22	559	14	356	10	254	3.5	89	453	206	none	
	8	75G	48.2	1224	27.0	686	10.0	254	20	508	14.7	373	26	660	16.5	419	12	305	3.5	89	906	412	none	
	10	12G	58.4	1483	36.5	927	11.5	292	20	508	17.5	445	31	787	20	508	14	356	5	127	1647	749	none	
	12	12G	61.0	1549	37.5	953	13.1	333	20	508	17.5	445	33	838	22	559	22	559	5	127	1744	793	none	
	14	14G	75.9	1928	47.0	1194	16.0	406	32	813	26	660	35	889	23.8	605	25	635	9	229	4316	1962	(4) 1-3/8"-8 UNC	
	16	14G	75.7	1923	47.0	1194	15.8	401	32	813	26	660	39	991	27	686	25	635	9	229	4728	2149	(8) 1-1/2"-8 UNC	
	18	14G	79.5	2019	48.8	1240	18.1	461	32	813	26	660	43	1092	29.3	743	25	635	9	229	6429	2922	(8) 1-5/8"-8 UNC	
	20	15G	99.4	2525	69.5	1765	20.5	521	32	813	26	660	47	1194	32	813	25	635	9	229	10039	4563	none	
	24	15G	107.8	2738	71.5	1816	23.5	597	32	813	26	660	55	1397	37	940	25	635	9	229	15000	6804	(8) 1-7/8"-8 UNC	

Torque & Turns Chart

Class 150

Size	Model	Torque (ft-lbs)	Turns
2	37H	46	1.4
2	37G	2	18
3	37H	114	1.5
3	37G	5	18
4	50H	123	2
4	55G	7	17
6	50H	163	2.9
6	55G	19	21
8	62G	41	22
10	62G	52	20
12	75G	70	27
14	75G	92	26
16	12G	104	46
16V	75G	92	26
18	12G	125	45
18V	12G	104	45
20	12G	158	45
20V	12G	150	45
24	12G	167	57
24V	12G	161	57
26	14G	207	62
28	14G	207	62
30	15G	214	63
36	15G	310	63

Class 300

Size	Model	Torque (ft-lbs)	Turns
2	37H	120	1.8
2	37G	2	18
3	37H	148	1.8
3	37G	5	18
4	50H	175	2.3
4	55G	19	18
6	62G	49	21
8	75G	105	29
10	75G	138	31
12	12G	184	45
14	12G	209	46
16	12G	250	40
18	12G	252	45
20	14G	255	55
24	14G	266	53
30	15G	538	62

Class 600

Size	Model	Torque (ft-lbs)	Turns
2	50H	161	1.5
2	55G	19	14
3	50H	161	1.5
3	55G	28	14
4	62G	38	18
6	75G	117	30
8	75G	129	30
10	12G	185	46
12	12G	219	50
14	14G	317	55
16	14G	323	55
18	14G	476	55
20	15G	562	56
24	15G	Consult Factory	

Models: H = Handwheel / G = Gear Operated

- Notes:**
- (1) Torque values shown are to unseat valve at maximum ΔP . Operator torques can be set up to 10% over this figure. **Electric actuators should be sized using a torque value that is 25% greater than the values listed above.**
 - (2) Turns may vary due to manufacturing tolerances and will affect operating times. Please allow +/-10% for operating times when choosing actuator gear ratio.
 - (3) Published torque values are for valves with Viton B elastomers. Please consult factory for required torque when valves contain alternative elastomers.

AUTOMATION

OmniSeal® expanding plug valves are available with Motor Adapter Kits (MAK's) designed to accept most commercially available electric actuators. We can install, set-up and test the actuators prior to shipment of the valves from our facility. Omni Valve also offers a complete range of hydraulic actuators. Please contact Omni sales for more information or a hydraulic actuator brochure.

ACTUATOR SIZING

Valve choice and actuator sizing depend on factors which include:

- Service Conditions (Media Type, Temperature and Pressure)
- Required Operating Speed
- Access to the Handwheel
- Available Power Source

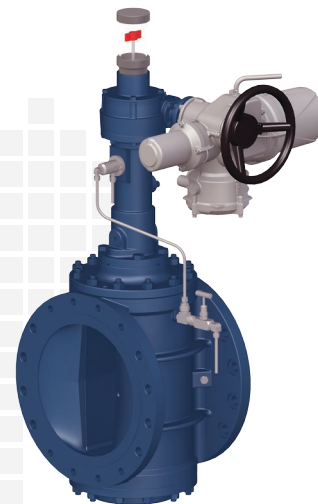

When OmniSeal® expanding plug valves are automated, it is necessary to employ a body cavity pressure relief system. This is due to thermal expansion. In addition to the ADTR systems shown on pages 12 and 13 there is an Automatic Body Bleed Valve (ABBV) relief system available. Its intended purpose is to alleviate the need for an operator to manually vent the body to atmosphere. This system utilizes a mechanical relief valve that is opened by the closure of the plug valve. When this relief valve is opened it is vented to the atmosphere or to a customer supplied catch basin.

If a relief system is not employed, the valve could be difficult to operate or could become stuck in the closed position.

Motor Adapter Kits

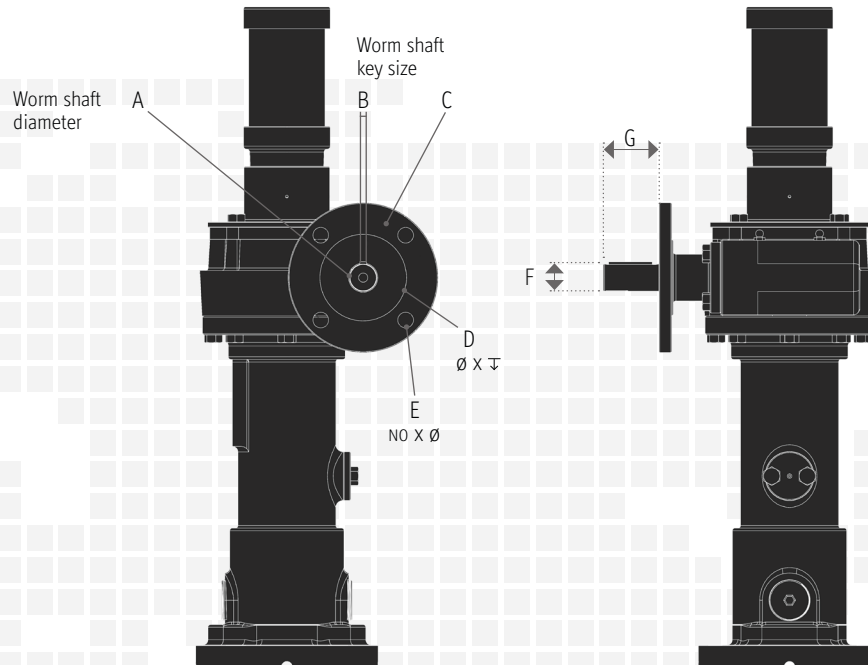

Operator	MAK Size	A	B	C	D	E	F	G	Max Torque
37G	F10	.865"- .870"	0.313"	Ø4.02"	Ø2.795" x .20"	4 x Ø.44"	.979"	1.54"	23
	F14	.865"- .870"	0.313"	Ø5.51"	Ø3.976" x .20"	4 x Ø.72"	.979"	1.54"	23
55G	F10	1.00"-1.002"	0.250"	Ø4.02"	Ø2.795" x .20"	4 x Ø.44"	1.109"	2.60"	75
	F14	1.00"-1.002"	0.250"	Ø5.51"	Ø3.976" x .20"	4 x Ø.72"	1.109"	2.60"	75
62G/75G	F10	1.245"-1.247"	0.313"	Ø4.02"	Ø2.795" x .20"	4 x Ø.44"	1.35"	2.60"	113/225
	F14	1.245"-1.247"	0.313"	Ø5.51"	Ø3.976" x .20"	4 x Ø.72"	1.35"	2.60"	113/225
	F16	1.245"-1.247"	0.313"				1.35"		113/225
12G	F10	1.245"-1.247"	0.313"	Ø4.02"	Ø2.795" x .20"	4 x Ø.44"	1.35"	2.53"	338
	F14	1.245"-1.247"	0.313"	Ø5.51"	Ø3.976" x .20"	4 x Ø.72"	1.35"	3.66"	338
	F16	1.245"-1.247"	0.313"	Ø6.50"	Ø5.17" x .24"	4 x Ø.88"	1.35"	3.66"	338
	F25	1.245"-1.247"	0.313"	Ø10.00"	Ø7.94 x .24"	8 x Ø.75"	1.35"	3.41"	338
14G/15G	F14	1.618"-1.622"	0.375"	Ø5.51"	Ø3.976" x .20"	4 x Ø.72"	1.820"	3.14"	404/703
	F16	1.618"-1.622"	0.375"	Ø6.50"	Ø5.17" x .24"	4 x Ø.88"	1.820"	3.14"	404/703
	F25	1.618"-1.622"	0.375"	Ø10.00"	Ø7.94 x .24"	8 x Ø.75"	1.820"	3.14"	404/703

- Notes:**
- (1) Column A dimensions are of the worm shaft diameter itself. Drive Bushing bores should have between .004" and .006" clearance over the shaft dimension.
 - (2) Kits contain stainless steel hardware to attach actuators. Customer must specify if actuators utilize Metric or US/Imperial hardware.

Standard Operator / DTR Configurations

OmniSeal® expanding plug valves with or without MAK's (motor adapter kits) can be configured with a variety of gear operator orientations to allow convenient operation of the hand wheel / actuator. This will allow the user to customize the location of the hand wheel or electric actuator control panel in relation to the personnel work platform. By altering the orientation of the gear operator and the left / right port of the DTR, the valve can be installed and operated without compromise. The orientations in 90° increments are shown below. The face of the valve that features the ADTR ports is considered the front of the valve. All orientations are in relation to the front of the valve as shown.

- Model 37G/ 55G can be rotated in 90° increments
- Model 62G/75G/12G can be rotated in 45° increments
- Model 14G/15G can be rotated in 30° increments

ORIENTATION "A"
LEFT



ADTR Left "L"

ORIENTATION "A"
LEFT



ADTR Right "R"

ORIENTATION "E"
RIGHT



ADTR Left "L"

ORIENTATION "E"
RIGHT



ADTR Right "R"

Standard Operator / DTR Configurations



ORIENTATION "C"
BACK



ADTR Left "L"

ORIENTATION "C"
BACK



ADTR Right "R"

ORIENTATION "G"
FRONT (STANDARD)



ADTR Left "L"

ORIENTATION "G"
FRONT (STANDARD)



ADTR Right "R"

Limit Switch Assemblies

Omni Valve can provide limit switch assemblies to meet most customer's specifications. We offer assemblies that utilize a clear protective cover between the flag and the limit switch as shown in Figure A. This configuration eliminates any external moving parts on the assembly.

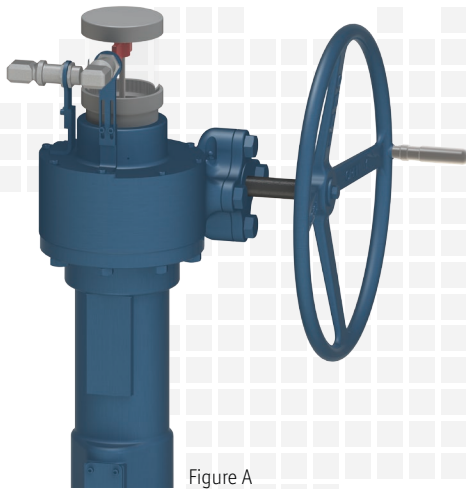

Figure A

The standard switch for this configuration is NAMUR style with a PBT thermoplastic housing that has a 10mm sensing range and utilizes a terminal compartment for wiring connections. Available approvals for this switch are listed below.

- A1. UL General Purpose
- A2. CSA General Purpose
- A3. ATEX EEx ia IIC/IIB-EEx ib IIC/IIB

An alternative configuration, without the protective cover, is available and is shown in Figure B. This configuration allows a much larger selection of limit switches to be used because there are no sensing range constraints.

The standard switch has a 300 series stainless steel housing and a 1/2" NPT conduit connection. The standard wiring is 18 gauge and is available in 3 ft, 6 ft, and 12 ft lengths. Contact Omni for custom wire lengths and other wiring and cabling options. The approvals for switches compatible with this configuration are listed below.

- B1. UL CI I Div 1 & 2 Groups A-D; CI II Div 1 & 2, Groups E-G
- B2. CSA CI I Div 1 Groups A-D; CI II Div 1, Groups E-G; CI III
- B3. CSA CI I, Div 2 Groups A-D; CI II, Div 2 Groups E-G; CI III
- B4. CSA General Purpose
- B5. UL General Purpose
- B6. ATEX/IEC Ex Zone 1 Ex d IIC; Ex tD; A21; IP66 T85C (-20° C to +50° C)
- B7. ATEX/IEC Ex Zone 1 Ex d IIC; Ex tD; A21; IP66 T85C (-20° C to +50° C) (Hermetically Sealed) (Model 73 & 7G-1 only) (Wiring H for HiTemp to +150° C)
- B8. ATEX/IEC Ex Zone 0Ex ia IIC T6 Ga Ex iD IIIC T85C Da (Tamb = -20° C to +50° C)
- B9. ATEX/IEC Ex Zone 0, Ex ia IIC T4 Ga, Ex iD IIIC T135C Da (-20° C to +100° C)
- B10. ATEX/IEC Ex Zone 0, Ex ia IIC T3 Ga (-20° C to +150° C) (Hermetically Sealed)
- B11. INMETRO BR-Ex d Gb, BR-Ex tD A21 T85C (-20° C to +50° C)
- B12. INMETRO BR-Ex d Gb, BR-Ex tD A21 T850C (-20° C to +50° C)
- B13. NEPSI Ex d IIC T3/T6

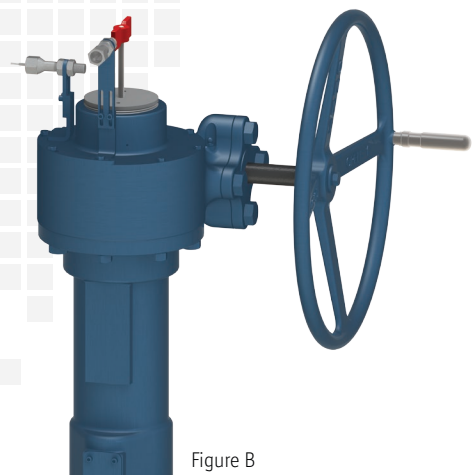

Figure B

Position Indicators and Locking Mechanisms



Omni Valve can provide a wide range of custom solutions to meet customer's specifications.

The beacon unit shown in Figure C provides an intrinsically safe enclosure that houses sensing switches and a visual valve position indicator. It can be configured with a wide variety of internal sensors including: Go switches, mechanical switches, inductive sensors, and proximity switches to meet each customer's specifications. The housing is capable of containing a variety of bus network boards to facilitate valve interface and communications. The enclosure is available in aluminum, resin, or stainless steel and can be ordered with standard or metric conduit entries. These assemblies can be certified with global agency approvals including, but not limited to: IECEx, ATEX, CE, UL, and CAS. Contact Omni for more information on beacon assemblies for specific applications.

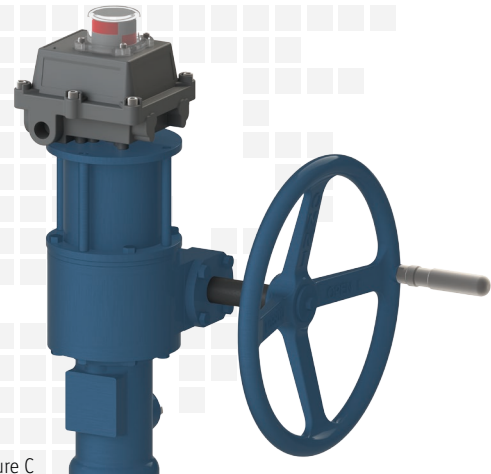

Figure C

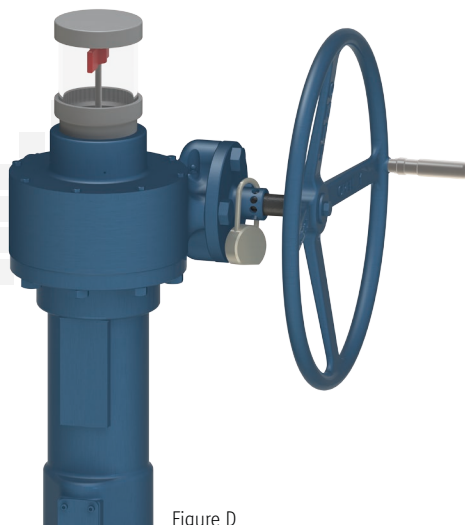

Figure D

Handwheel locking devices, as shown in Figure D, are available for the entire product line of OmniSeal® expanding plug valves to discourage tampering. These locking devices are secured using a padlock or similar mechanism and lock the valve in either the fully open or fully closed position.

Stem Extensions

OmniSeal® DB&B expanding plug valves are offered with a variety of extension options. Gear box / operator extensions move the operator station farther away from the flow bore of the valve. These types of extensions function the same for actuated or hand wheel operated valves. They are useful when the valve is located below grade or below a catwalk.

Hand wheel extensions move the hand wheel farther from the center line of the operator. These may be necessary when the valve is located too far from existing operator platforms.

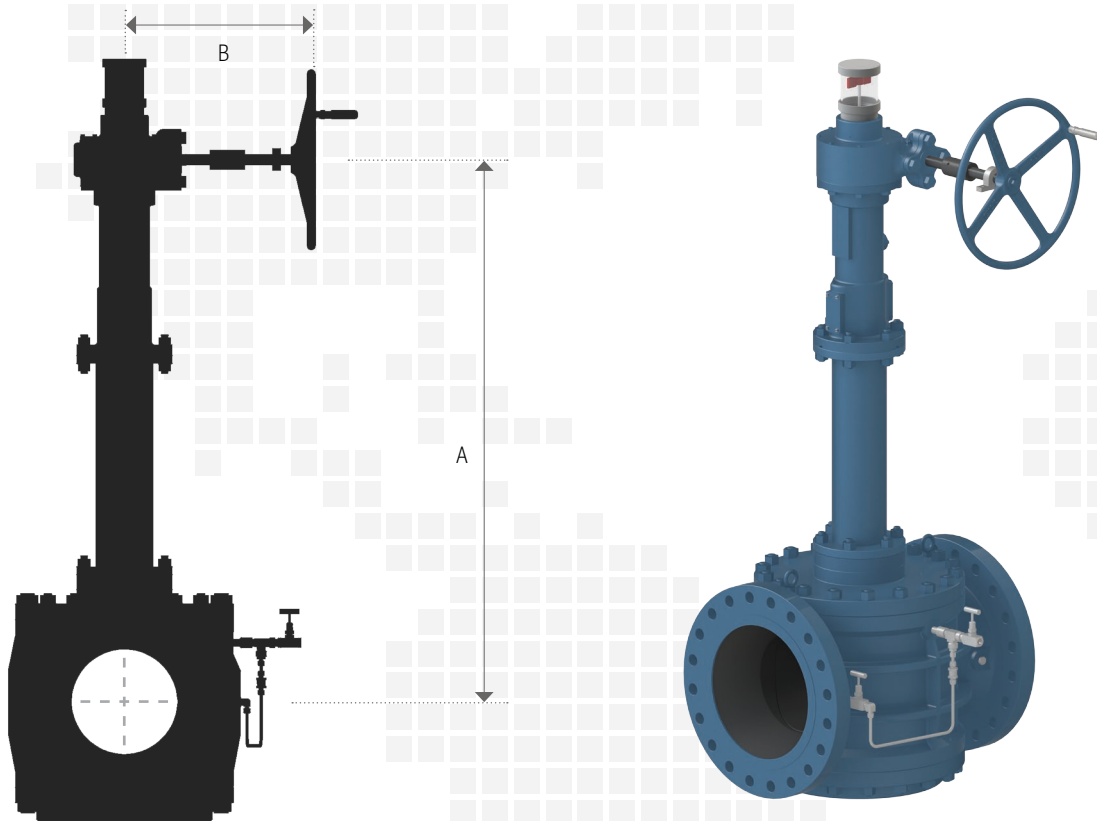

Valve depicted is an OmniSeal® 16" Class 300

OPERATOR TYPES

TYPE 1 – OPERATOR EXTENSION Suitable for underground burial. Specify dimension **A** when ordering.

TYPE 2 – OPERATOR EXTENSION Exposed and not suitable for burial. Specify dimension **A** when ordering.

TYPE 3 – HAND WHEEL EXTENSION It is advisable to support all hand wheel extensions. A bearing block will be supplied with all extensions for additional support by mounting to customer supplied structure. Specify dimension **B** when ordering.

Replacement Parts and Rebuild Kits



SPARE PARTS

Omni Valve stocks a complete line of replacement parts for the OmniSeal® DB&B expanding plug valve.

Please contact an Omni Valve sales representative for more information.



SLIPS

Slips for each plug valve size in standard Viton B trim are available off the shelf. Alternative seal materials are available upon request.

INDICATOR PROTECTOR CAPS

Indicator protector caps and shipping caps are available for all sizes.

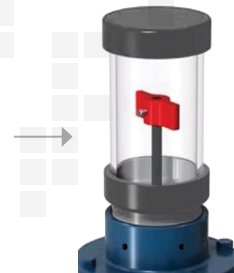

RELIEF SYSTEMS AND COMPONENTS

Standard relief systems and components for each valve size are available off the shelf. Custom relief systems available upon request.

Omni Valve stocks various rebuild kits for the OmniSeal® DB&B expanding plug valve as follows.

Please contact an Omni Valve sales representative for more information.

KITS

CLOSURE KIT (CK)

- (1) Body O-Ring and (1) Fire Seal Body Gasket.
A closure kit is required for each of the upper and lower bonnets.

STEM KIT (SK)

- (1) Stem Packing Set, (1) Stem Seal ID O-Ring and (1) Stem Seal OD O-Ring.

REBUILD KIT (RK)

- (2) Closure Kits and (1) Stem Kit.

MOTOR ADAPTER KITS (MAK)

- (1) Actuator Mounting Flange and (1) Stem Spacer Sleeve and hardware.

OPERATOR GASKET KITS

All gaskets associated with operator.

Notes:

- (1) Stem packing is pre-formed flexible graphite.
- (2) O-Rings are 75D Viton B unless otherwise specified.
- (3) Gaskets are flexible graphite unless otherwise specified.

Figure Numbers

OmniSeal® figure numbers provide an easy way to specify the valve you need and communicate with Omni Valve or its distributors.

Please use the following format to determine the appropriate figure number for valve sizes or configurations:

CLASS – SIZE / OPER / MAK (optional)

CLASS

These digits refer to the ANSI class of the valve.

150 = ANSI Class 150, 300 = ANSI Class 300, 600 = ANSI Class 600

SIZE

These digits refer to the valve size.

2 = ANSI 2", 3,4,6,8,10,12,14,16,18,20,24,28,30,36, etc.

OPERATOR

These digits refer to the valve operator.

Handwheel Operators

37H, 50H

Gear Operators

37G, 55G, 62G, 75G, 12G, 14G, 15G

OPERATOR ORIENTATION

 (See pages 20–21)

A = Left C=Back E=Right G=Front

ADTR

L = Left R=Right

MAK

These letters are only used if a MAK (Motor Adapter Kit) is required for the valve to be automated.

EXAMPLE:

A) 8" ANSI 300 Gear Operated, with MAK

- 1) CLASS – 300
- 2) SIZE – Dash 8
- 3) OPERATOR – Slash 75G
- 4) OPERATOR ORIENTATION – Slash G
- 5) ADTR – Slash L
- 6) MAK if required – Slash MAK

Figure number for above: **300-8/75G/G/L/MAK**

B) 10" ANSI 150, Gear Operated: 150-10/62G/E/L

Note: If specifying a reduced face-to-face pattern valve (for 16,18, 20 and 24" Class 150 valves only)
The figure number is the same except a "V" added to the number in the class section

Figure number: **V150-18/12G/A/R**

If MAK if required: **V150-18/12G/A/R/MAK**

Manufacturing, Trademarks & Product Warranty



EXCLUSIVE MANUFACTURER FOR OMNISEAL® DB&B EXPANDING PLUG VALVES

ALL OmniSeal® DB&B expanding plug valves are manufactured by Omni Valve's trusted business partner Ghatge Patil Industries LTD (GPI) in India. GPI has an ownership position in Omni Valve and its engineering, procurement and quality systems are seamlessly integrated with those of Omni Valve.

Omni Valve and GPI recognize that in today's competitive global marketplace, delivery time frame and/or logistical concerns play a key role in the success of many projects. Therefore all OmniSeal® DB&B expanding plug valve orders can be delivered from either Omni Valve's USA location or GPI's location in India depending on project requirements or customer preference. Since Omni Valve and GPI are so tightly integrated, customers can be sure that all valves have been subjected to identical quality control measures.



TRADEMARKS

OmniSeal® is a registered trademark of Omni Valve. The OmniSeal® brochure contains references to other registered trademarks that are not owned by Omni Valve.

Trademarks	
Viton	DuPont Performance Elastomers L.L.C.
Go Switch	Emerson Process Management

PRODUCT WARRANTY

For product warranty information please visit: omnivalve.com/warranty.shtml



OmniSeal® Expanding Plug Valves



Global Energy Market Solutions



ABSOLUTE ZERO LEAKAGE



OmniSeal[®] Double Block & Bleed Expanding Plug Valve

OmniSeal[®] Tecnoval[®] Global Sales

1301 E. 8th. St. Suite 208 | Mission, Tx 78572 |

 (956)782-1111 ; (956) 227-6332

 sales@tecnovalv.com

OmniSeal[®] TecnoSteel S.A. de C.V.

Dr. José Ma. Cantu No. 312 Col. Doctores , Cd.

Reynosa, . C.P. 88690 (899) 871-3766

Tel: +52 (899) 995-4041 ; +52

ventas@tecnosteel.com.mx

Request For Quote



ventas@tecnosteel.com.mx