

Report of the
Parking Lot Committee

November 5th, 2020 at 10 AM

Members attending in the Valhalla Party Room were Mike Fenske- co-chair, Jim Iverson- co-chair, Elaine Wiegert, Lou Ohly, Dan Bredesen, Maintenance Supervisor, Jason Dietz, Maintenance Lead, and Stacy Wilhelm, General Manager. Linda Castiglioni attending remotely.

Reserve Parking- The committee reviewed the attached handout and supports the recommendation of removing the reserve parking spaces located in the middle of the lot, and only having reserved parking spaces available next to the curb or sidewalks. This would allow adequate signage, but not be in the way while maintaining the lot. It was noted with the low number of reserved spaces being rented, there should be no negative impact on the building's income from reserve parking. Also, clarification in reserved parking and assigned parking was made. Building 10 has assigned parking for each resident of the building, which is not charged to the residents. Buildings 1-9 and 11, have a number of reserve parking spots that are rented yearly as income for the association.

Blocking entrances trial run- Elaine brought forward concerns with closing entrances by buildings 6 and 7 and piling snow at the entrance of 10. After discussion, the committee decided against blocking off the entrances before construction.

Lighting update- The committee reviewed placement and fixtures of current buildings and parking lot lighting, as well as options for additional improvements. The committee discussed the lighting located in the middle of the parking lot, and that it will be removed during the parking lot project. Further discussion on parking lot lighting options, for safety, coverage, and concerns of overflowing with light followed. The committee recommends updating all building and garage lighting with exterior building lighting; or wall packs; and not installing pole lighting; similar to streetlamps. It was noted that, after the lighting update was completed it would be easier to assess the lighting coverage and add more if needed. Management also made the committee aware that the garage's power will be disconnected during construction, and tenants will have to access their garages with a key rather than their remote. The length of time without power is unknown as it depends on the length of the construction project. More information regarding the construction phases will be provided once a vendor is determined.

The committee also discussed updating the current pathway globe lighting. It was noted that many of the internal drivers of the fixtures are failing, and replacement parts are increasingly hard to find. It was clarified that this would be replacing the fixture and not the pole. After discussion, the committee recommends updating the fixtures of the pathway lighting.

Landscaping- The committee reviewed a proposal given during the bidding process for replacing the retaining walls and landscaping around buildings 1, 2., & 3. Other retaining walls around the complex were further discussed. The committee has requested a bid for the retaining walls around the recreational area. The current railroad ties are in good shape, however when replacement is needed down the road that would result in big

equipment traveling on the new parking lot. It was agreed that the update may make more sense during the parking lot project. Management will obtain bids for the recreational building and building 12's retaining walls.

With nothing further to discuss, the meeting was adjourned at 11:18AM.

In summary, the PLC proposes the following motion be made at the next RAMB meeting:

1. The committee recommends changing the number and location of reserved parking as specified on the attached handout.
2. Updating all the exterior wall pack building lighting, pathway lighting, and budgeting for the power shut off as specified in the attached handout.

Submitted by Stacy Wilhelm

Proposed Change to
Reserve & Assigned Parking

Building	Currently	Proposed change	Reserved as of 11/5
1	8	11	5
2	10	5	5
3	12	10	7
4	12	12	0
5	16	21	0
6	3	19	2
7	8	15	3
8	12	8	6
9	18	11	2
10	24	24	24 (assigned parking)
11	14	9	
Totals	137	145	54

Assigned parking- Each resident is assigned a parking space at no charge.

Reserved parking- Residents pay a yearly fee to reserve a parking spot. This is income for that building.

MB Approved
11.2020

Recommended Complex Lighting Update

Bldg	Wall Pack Lighting		Power Shut Off		Pathway Lighting	
	#	\$500	Ea. Bldg.	Shared	#	\$1,000
1	3	\$1,500	\$500	\$24		\$660
2	3	\$1,500	\$500	\$31		\$880
3	3	\$1,500	\$500	\$31		\$880
4	4	\$2,000	\$500	\$31		\$880
5	7	\$3,500	\$500	\$39		\$1,099
6	3	\$1,500	\$500	\$24		\$660
7	4	\$2,000	\$500	\$24		\$660
8	5	\$2,500	\$500	\$39		\$1,099
9	5	\$2,500	\$500	\$31		\$880
10	4	\$2,000	\$500	\$31		\$880
11	7	\$3,500	\$500	\$31		\$880
12	6	\$3,000	\$500	\$84	4	\$6,346
15	0	\$ -		\$79		\$2,199
Totals	54	\$27,000	\$6,000	\$500		\$18,000

**Total Wall pack, power
allowance, & pathway**

\$2,683
 \$2,911
 \$2,911
 \$3,411
 \$5,139
 \$2,683
 \$3,183
 \$4,139
 \$3,911
 \$3,411
 \$4,911
 \$9,929
\$2,277
\$51,500



WMG : LED WALLPACK GLASS

DESCRIPTION

- Dimming standard on 3C, 4C and 5C models
- UV stabilized powder-coated bronze finish
- Enclosure and hardware are corrosion resistant

LISTINGS

- UL Listed for wet locations
- IP65 Rated
- DesignLights Consortium® Qualified - meets DLC requirements for efficacy and lumen maintenance

LED CHARACTERISTICS

- Rated lifetime L70: 50,000 hours
- 4000K, 5000K CCT
- CRI: 70+

ELECTRICAL

- Input voltage: 120-277V; 347-480V
- Power Factor: >.90
- THD: <20%

THERMAL

- -40°F to 104°F (-40°C to 40°C) operating temperature

CONSTRUCTION

- Die-cast aluminum body with traditional HID appearance
- Multiple ½" NPS entry points for conduit and accessories
- Fully sealed and gasketed
- Borosilicate tempered glass lens

WARRANTY

- 5 year limited warranty; see eiko.com for warranty details

project name	type
catalog number	
comments	voltage
approved by	date



WMG-1C



WMG-2C/3C/4C



WMG-5C

APPLICATIONS

- Industrial Parks
- Loading Docks
- Utility Sheds
- Entryways
- Walkways
- Storage Areas
- Security



ORDERING INFORMATION

EXAMPLE: WMG-1C-40K-U

Model	Package	CCT	Voltage
WMG : LED Wallpack Glass	1C - 30W; 3,200 lm 2C - 40W; 4,600 lm / 50W; 5,800 lm 3C - 60W; 7,000 lm 4C - 80W; 9,800 lm 5C - 120W; 13,000 lm	40K - 4000K 50K - 5000K	U - 120-277V V - 347-480V

LPT-1



APPLICATION

LED decorative lights provide high light efficiency, various optional light distributions. Replace metal halide and high pressure sodium lamp for energy saving with a driver inside. It is designed to work in building perimeter areas and public spaces completing a wide variety of architectural styles.

FEATURES:

- Die cast aluminum thimble. 2-3/8" (60mm) diameter pole is standard.
- Light fixture structure is without and hazardous material.
- Prism shaped anti-UV polycarbonate transparent diffuser.
- 11.9lbs (5.3kg)
- EPA: 0.8925 sqft

LED:

- Color Temperature: 3000/4000/5000(K)
- CRI: >70
- 120° distribution.
- LED Module: High efficiency up to 100 lm/W.
- Service life: Greater than 50,000 hours(L₇₀) minimizing maintenance frequency.
- Proprietary binning for uniform color.

ELECTRICAL:

- Ambient Operating Temperature: -4°F (-20°C) ~ 113°F (45°C).
- Power Factor: >0.95
- Input Voltage: 120V-277V, 50/60Hz

LISTING:

- cETLus listed.
- LM79, LM80 available.
- 5 years warranty.
- Suitable for wet location.
- ARRA compliant. (optional)

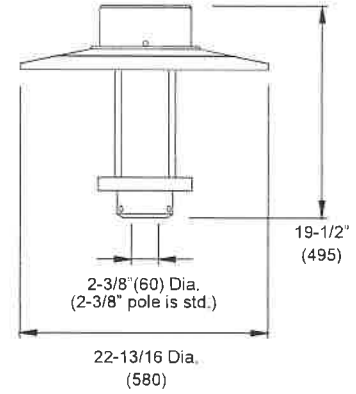

* All dimensions are in inches (millimeters).

Default Sensor Setting	
Detection Sensitivity	100%
Hold Time	90s
Day Light Sensor	Disable or 50lux
Stand by Time	10min
Stand by Dimming Level	10%

CONFIGURATIONS

	Input Watts	Lumen Output
LPT-1	35W	3500 lm
	40W	4000 lm
	50W	4500 lm

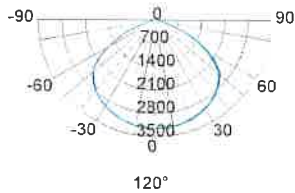

LPT-1-35LED

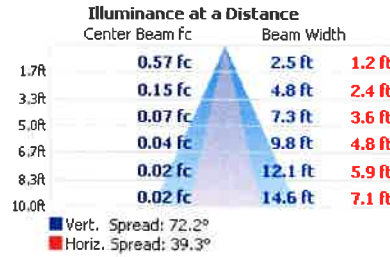

LPT-1-50LED

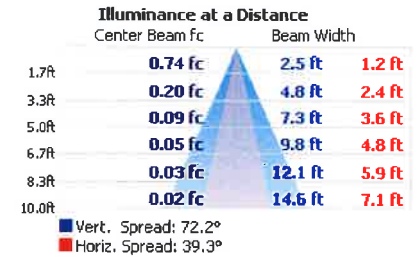

ORDERING INFORMATION

EXAMPLE: LPT-1-35LED-30K-UNV-BK

MODEL	LED	COLOR TEMP.	VOLTAGE	FINISH	MOUNTING
LPT-1	35LED 35W 40LED 40W 50LED 50W	-30K 3000K -40K 4000K -50K 5000K	UNV 120-277V (Std.)	BZ Bronze (RAL#8019) (Std.) CC Custom Color	(Blank) 2-3/8' Pole

* Available custom color (RAL)
Please provide us with the RAL number.
† Non-standard finish with extra charge.

CONTROL		OPTIONS	
(Blank) None DM 0-10V ² PC3 With Photocell - Button Type 120/277V TLPC Photocell (Twist Lock) M/D Motion Sensor, Integrated with photocell ¹	BG Bird Guard, Stainless Steel Spikes RC7 NEMA 7-wire receptacle only (no controls) ARRA Assembled in USA for Buy American act		



- NOTES:
1. Dawn and dusk plus motion detection with different light level. (0-10V dimming approach)
 2. Only available with 40W or higher wattage options.