

Model 118W

- Fire-rated frame for resistive glass that has a layer of intumescent
- Setting blocks position glass to allow expansion.
- 1.5" maximum pocket in 1.75" door.
- Fasteners go through door.

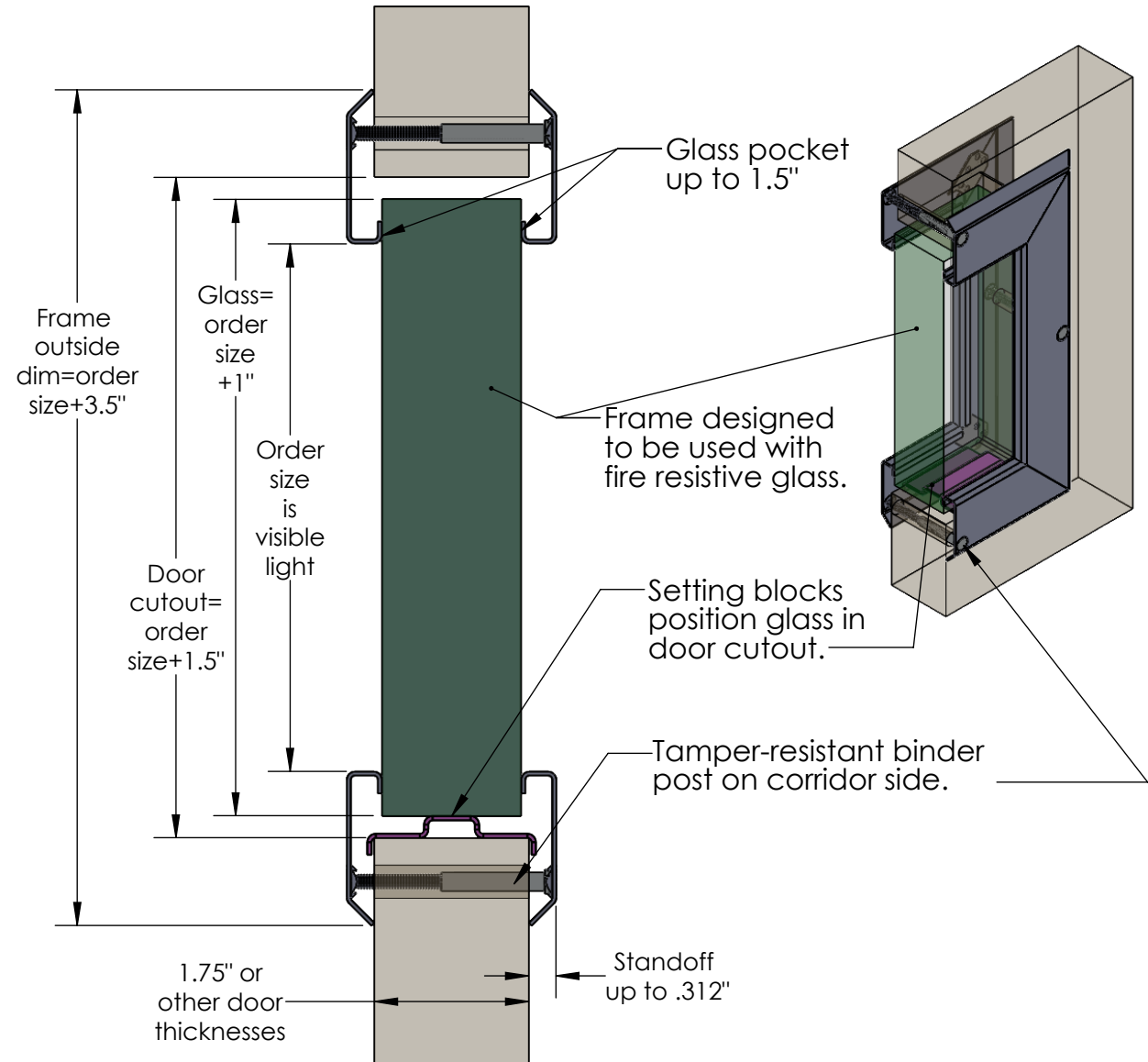

This frame may be installed with most fire-rated glazing material that has approval for conformance to ANSI/UL 10B, ANSI/UL 10C, NFPA 80, NFPA 252, or CAN/ULC S104. Contact AMS for frames intended for use with resistive glass.

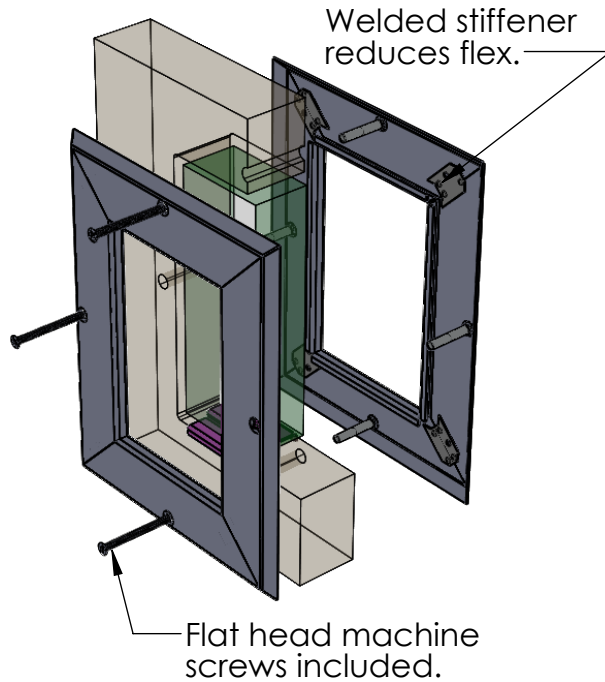

Materials & Finish

- 18 ga mild steel standard.
- Galvanized or stainless steel available.
- Extremely durable powder coating.
- Beige, gray & dark bronze standard.
- RAL & custom colors available.
- Real wood veneer.



411 W Spruce St.
Abbotsford, WI 54405
715.223.6324

MODEL 118W

INSTALLATION INSTRUCTIONS

Special fire door lite frame with setting blocks

See package label for Model # and Order Size
For top coating instructions, see page 2



Order Size = Inside dimension of frame
Cutout Size = Order Size + 1-1/2"
Glass Size = Order Size + 1"

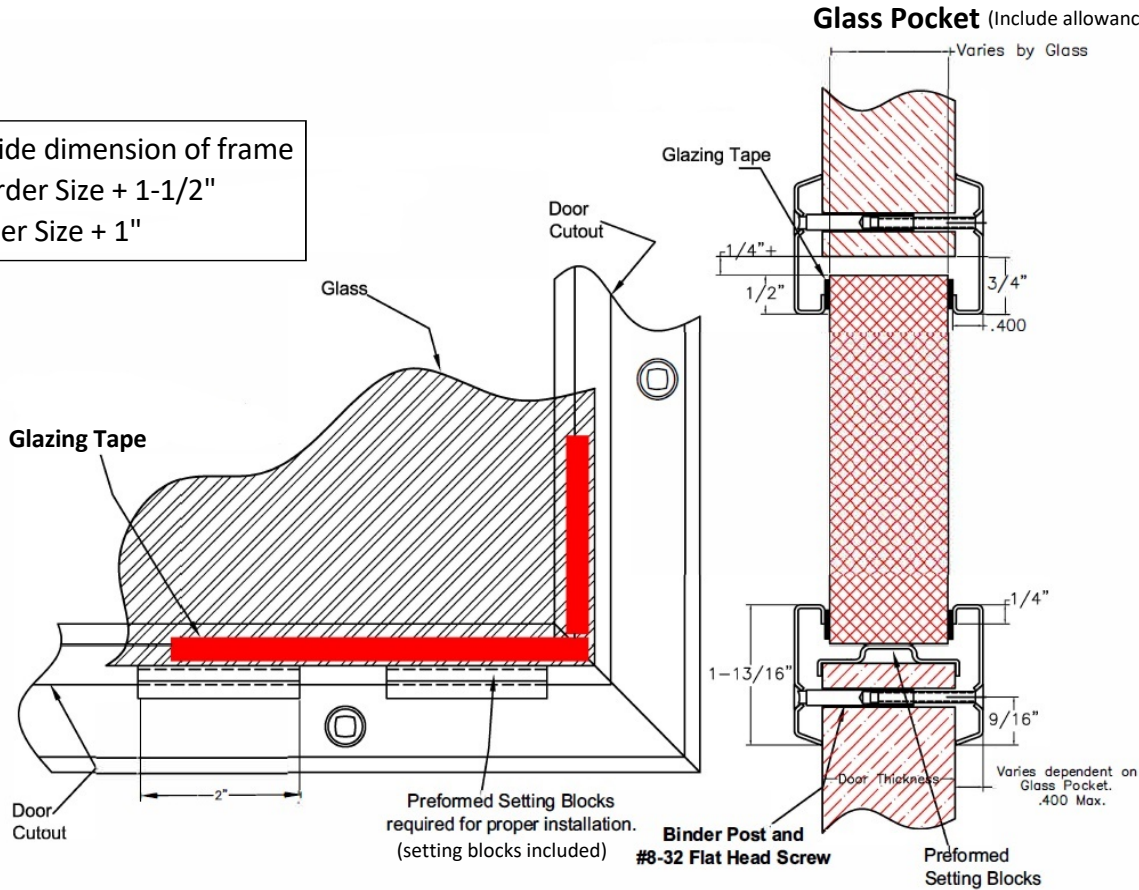

NOTE ON GLAZING TAPE: Some types of glass & some very large frames require glazing tape. Scan the QR Code (right) or visit www.allmetalstamping.com for a listing of approved glazing, fire ratings, and glazing tape requirements.



Steps to Install

1. Make door cutout in accordance with "Cutout Size" listed above. Cutout should be rectangular. It is not necessary to square the corners. **For fire rated applications in steel doors, reinforce the cutout per your UL/WHI procedure or follow the AMS procedure on page 2.*
2. Place two (2) 2" preformed setting blocks (included) evenly spaced on bottom of cutout.
3. Use one half of frame unit as a drilling template. Mark holes. Drill door using 3/8" drill.
4. If tape is required, install to both sides of the glass. Glass is seated 1/2" in frame. TRIM ANY EXCESS TAPE SHOWING AFTER INSTALLATION.
5. Place 1st frame half in opening as shown above.
6. Place glass on setting blocks, align in opening. Put 2nd frame half in place and begin installing binder posts and screws.
DO NOT OVER-TIGHTEN SCREWS. UNEVEN TIGHTENING OR OVER-TIGHTENING CAN CAUSE GLASS BREAKAGE.

Top Coating Instructions

Standard Finish: Beige, Gray, or Dark Bronze polyester powder coatings. These coatings are tough, corrosion resistant and provide a very durable surface. Special colors are lacquer, industrial enamel, or powder coatings dependent on color.

Top Coating Fire Door Hardware: Many top coats have good compatibility with powder coatings. Exceptions are some enamels and many latex and water based paints. It is necessary that the surface be thoroughly sanded prior to the application of any top coat. Make sure the surface is clean and dry. To ensure compatibility, test paint a small area on a non-visible portion of the product and check for proper adhesion before proceeding. Final finish of the product is the responsibility of the purchaser. We do not warrant the suitability of the product for any particular application.

Installation Instructions Hollow Metal Door Clip (24 Ga. Galvanized Steel)

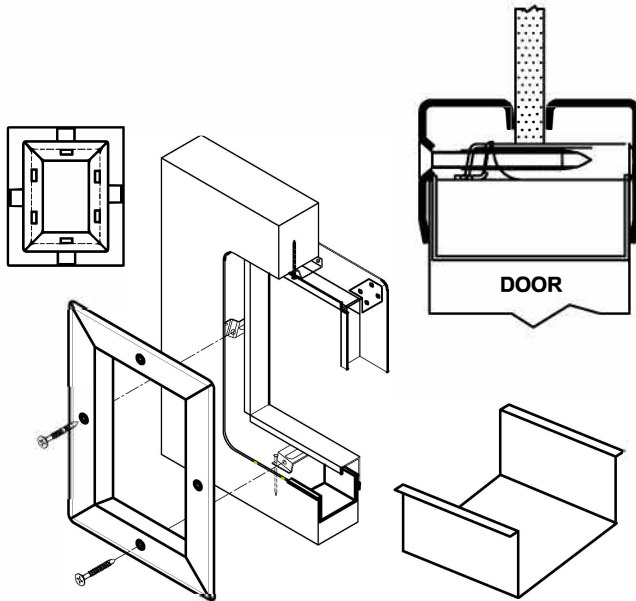

Refer to door manufacturer's installation instructions. If approved to use a clip system follow those instructions as to the number of clips required.

Minimum Requirements
A minimum of 1 clip per side - centered. Any side over 50" requires 2 clips per side evenly spaced.

Door Thickness: 1 $\frac{3}{4}$ " Doors ONLY.

AMS Part No.: 1175-A08

Installation Instructions Hollow Metal Door Perimeter Channels (18 Ga. CRS)

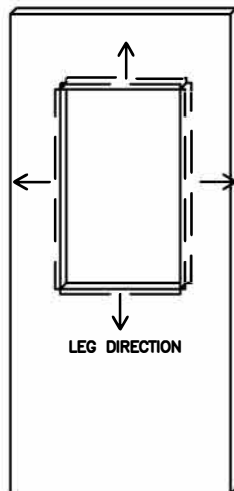

1. Cut top, bottom, and side channels the same length as the cutout dimensions.
2. Install channels by tapping into the opening until channels are flush with cutout.
3. Tack weld into place.

LIMITED WARRANTY: ALL METAL STAMPING, INC. WARRANTS ALL DOOR HARDWARE TO BE FREE FROM DEFECTS IN MATERIALS AND WORKMANSHIP. Purchaser assumes responsibility to verify and determine that color, finish, and quality of materials will meet required specifications. No claim shall be allowed unless Purchaser gives notice to manufacturer within 30 days from the date materials are received. If color match, finish quality, or glass and cutout fit are not satisfactory, **DO NOT INSTALL. UPON INSTALLATION THIS WARRANTY ENDS. Manufacturer's only obligation shall be replacement, refinishing, or refund of the original purchase price, at our option. THESE ARE THE EXCLUSIVE REMEDIES PROVIDED, AND ALL METAL STAMPING, INC. SHALL NOT BE LIABLE FOR ANY OTHER DAMAGES, INCLUDING ANY OTHER DIRECT, INDIRECT, INCIDENTAL OR CONSEQUENTIAL DAMAGES.** This warranty does not apply to door hardware which has been abused, altered, improperly installed, used with incompatible or inappropriate components (EX. Oversized Glass), exposed to corrosive environments, or environments for which the product is not intended. No material shall be returned without prior authorization. This warranty extends only to the original Purchaser who is buying the hardware from All Metal Stamping, Inc. for purposes of resale or use in the ordinary course of their business.