

D

D

C

C

B

B

A

A

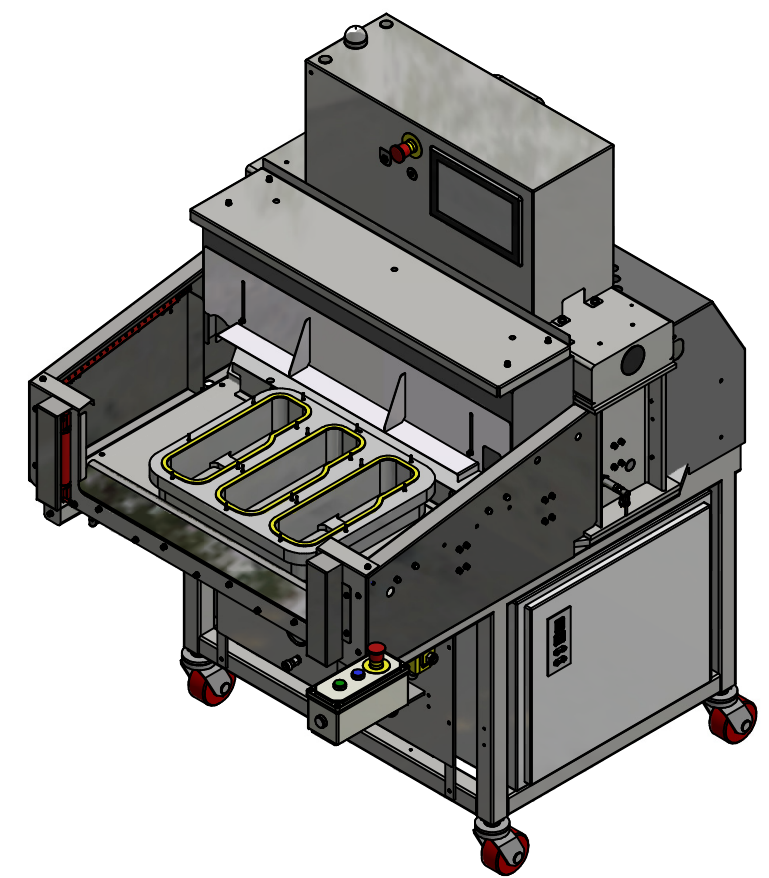
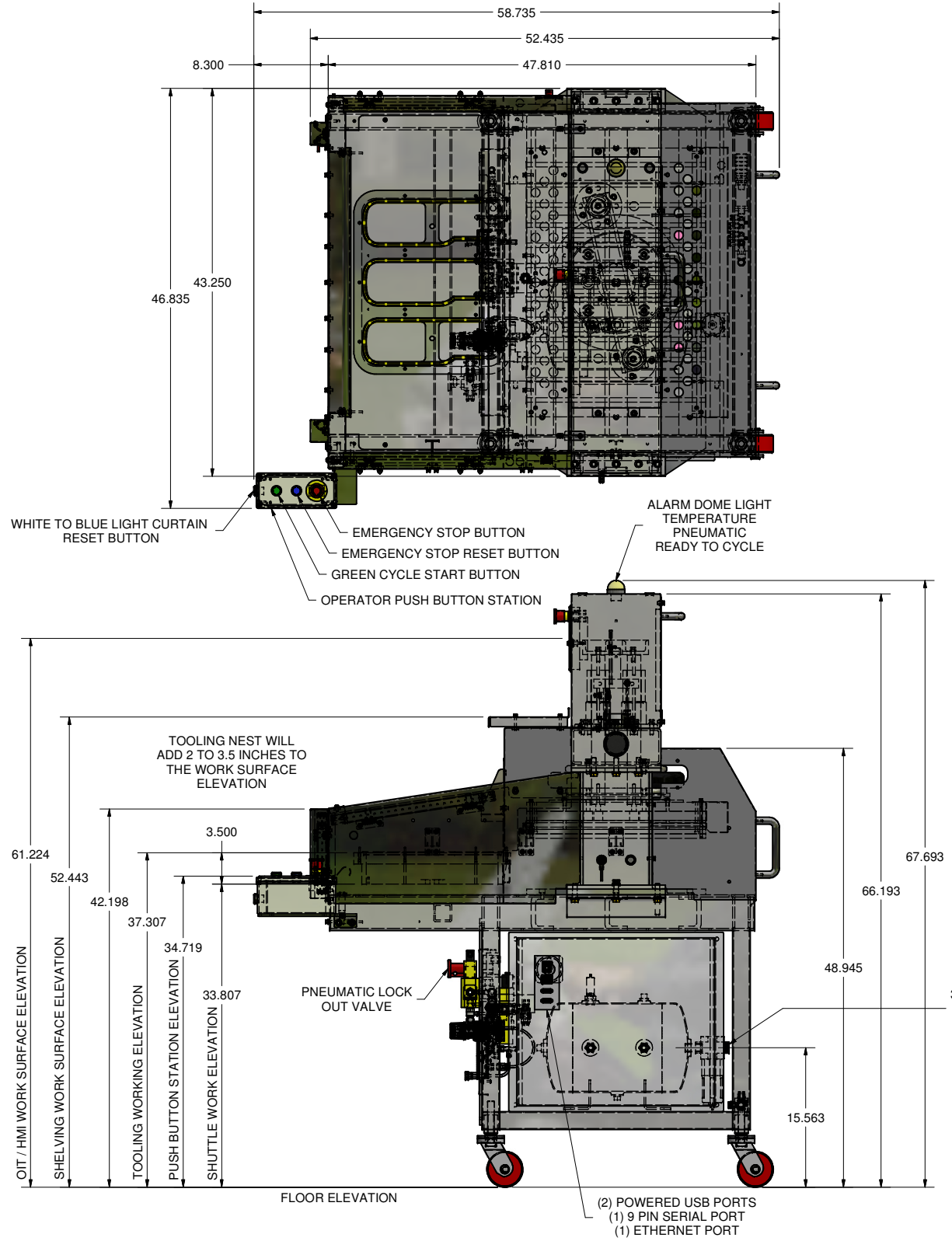
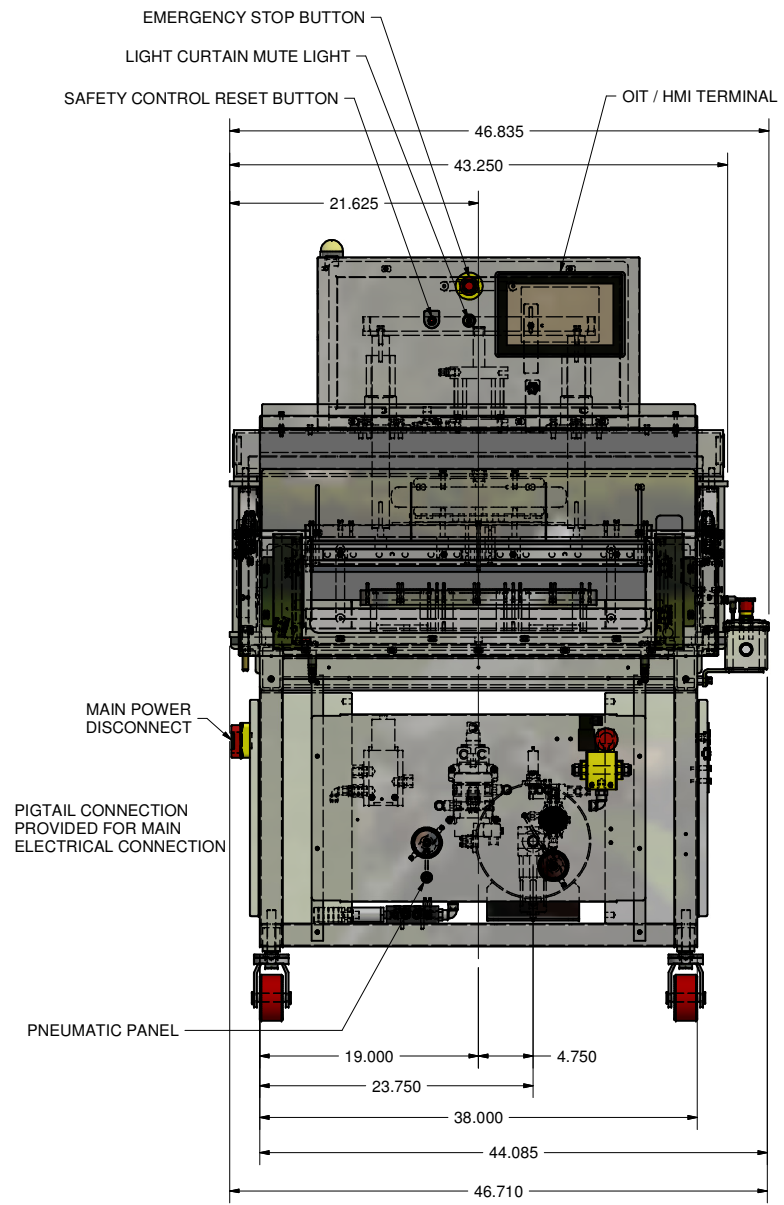

STATEMENT OF OWNERSHIP: THIS MATERIAL IS THE EXCLUSIVE PROPERTY OF ATLAS VAC MACHINE LLC AND MUST BE RETURNED TO ATLAS VAC MACHINE LLC IMMEDIATELY UPON REQUEST. THIS MATERIAL AND THE INFORMATION ILLUSTRATED OR CONTAINED HEREIN MAY NOT BE REPRODUCED, COPIED, USED OR TRANSMITTED IN WHOLE OR PART IN ANY WAY WITHOUT THE PRIOR WRITTEN CONSENT OF ATLAS VAC MACHINE LLC. UNLICENSED DUPLICATION OF ANY ATLAS VAC MACHINE LLC COMPONENT OR ASSEMBLY ILLUSTRATED IN WHOLE OR PART IS PROHIBITED AND SUBJECT TO PROSECUTION.

UNLESS OTHERWISE SPECIFIED DIMENSIONS ARE IN INCHES. TOLERANCES ARE: .X ±.1 ANGLES ±1° .XX ±.015 SURF FINISH 125 .XXX ±.005 SURF FINISH V DO NOT SCALE DRAWING THIRD ANGLE PROJECTION		CONTRACT NO.		Atlas Vac Machine PO Box 42633, Cincinnati, Ohio 45242	
APPROVALS		DATE			
DRAWN Mike		2/25/2022		DESCRIPTION	
CHECKED				1830S TRAY SEALER ASSEMBLY	
ENGR				SIZE CAGE CODE DWG. NO. REV.	
DESIGN Mike		4/25/2019		D 99296 2252022-SK	
TREATMENT MFG				SCALE CALC. WTT ACT. WTT SHEET 1 OF 1	
FINISH		CAD FILE NAME 004621-000.idw			

DWG NO. 2252022-SK

SH 1 REV

N:\Atlas Vac Models, R&D\18-30 Dual Side Updated\004621-000.idw