

8

7

6

5

4

3

DWG NO. 5222023-SK

SH 1 REV

1

D

D

C

C

B

B

A

A

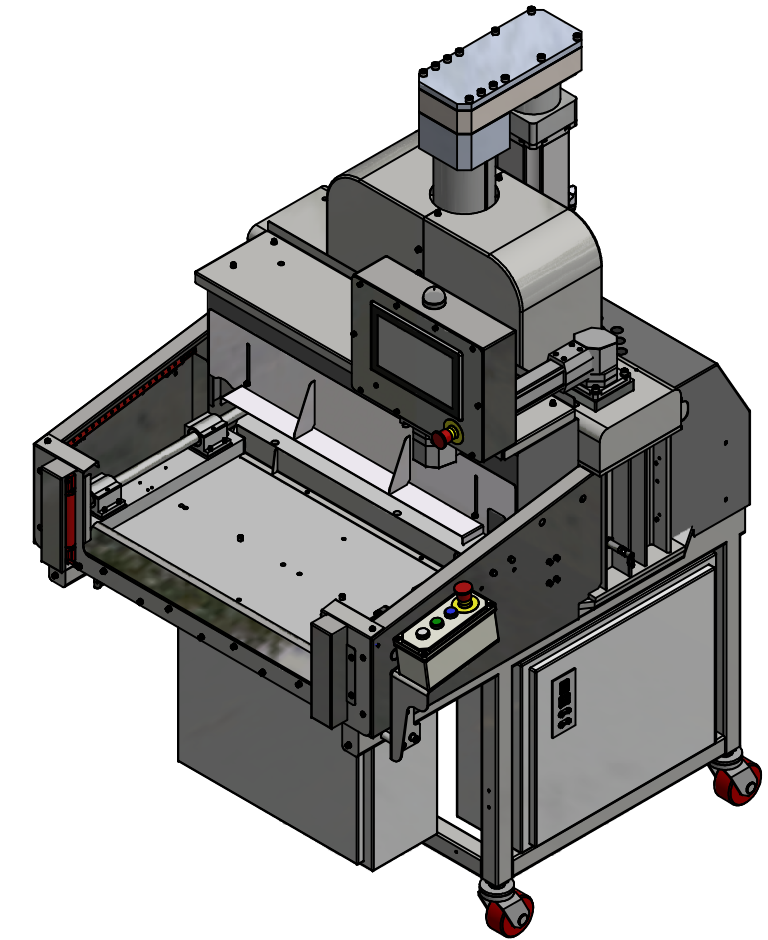
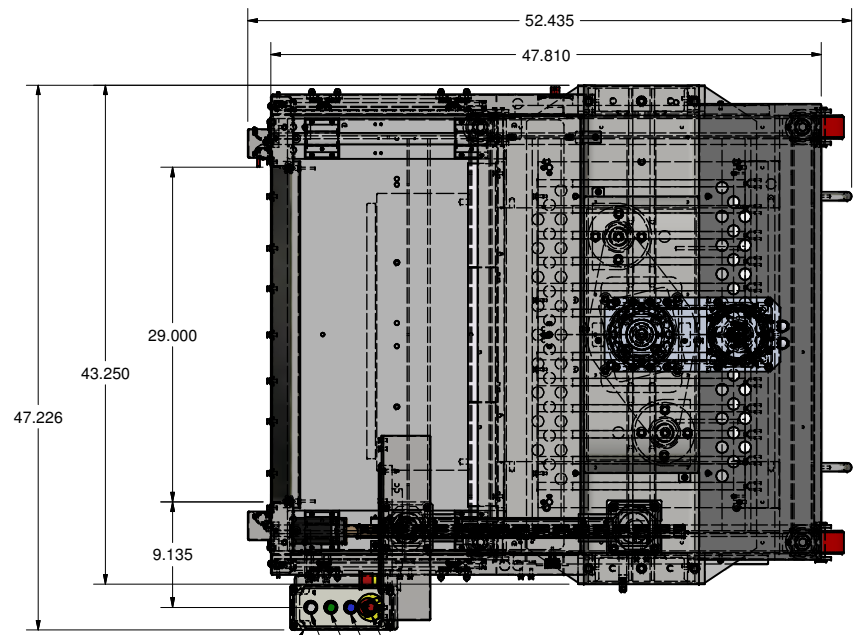

- OPERATOR PUSH BUTTON STATION
- EMERGENCY STOP BUTTON
- EMERGENCY STOP RESET BUTTON
- GREEN CYCLE START BUTTON
- WHITE TO BLUE LIGHT CURTAIN RESET BUTTON

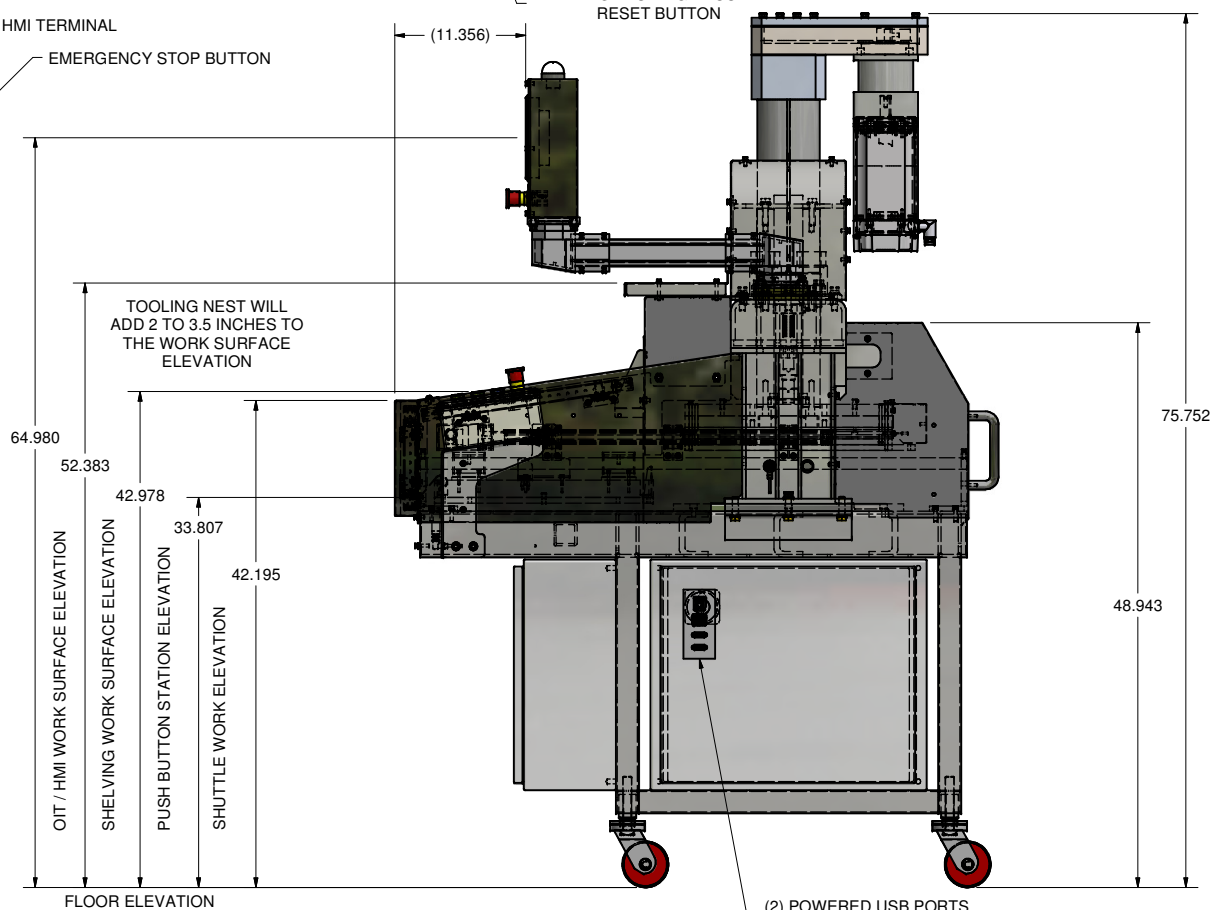
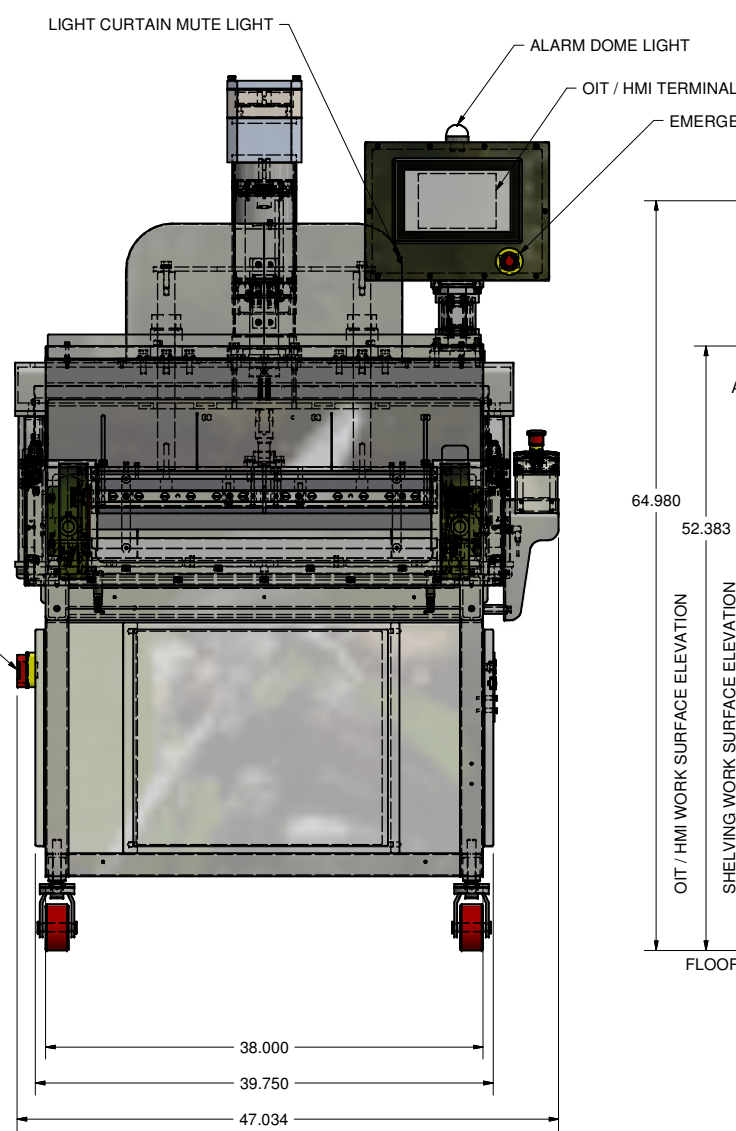

TOOLING NEST WILL ADD 2 TO 3.5 INCHES TO THE WORK SURFACE ELEVATION

- (2) POWERED USB PORTS
- (1) 9 PIN SERIAL PORT
- (1) ETHERNET PORT

- OIT / HMI WORK SURFACE ELEVATION
- SHELVING WORK SURFACE ELEVATION
- PUSH BUTTON STATION ELEVATION
- SHUTTLE WORK ELEVATION
- FLOOR ELEVATION

- 38.000
- 39.750
- 47.034

STATEMENT OF OWNERSHIP: THIS MATERIAL IS THE EXCLUSIVE PROPERTY OF ATLAS VAC MACHINE LLC AND MUST BE RETURNED TO ATLAS VAC MACHINE LLC IMMEDIATELY UPON REQUEST. THIS MATERIAL AND THE INFORMATION ILLUSTRATED OR CONTAINED HEREIN MAY NOT BE REPRODUCED, COPIED, USED OR TRANSMITTED IN WHOLE OR PART IN ANY WAY WITHOUT THE PRIOR WRITTEN CONSENT OF ATLAS VAC MACHINE LLC. UNLICENSED DUPLICATION OF ANY ATLAS VAC MACHINE LLC COMPONENT OR ASSEMBLY ILLUSTRATED IN WHOLE OR PART IS PROHIBITED AND SUBJECT TO PROSECUTION.

UNLESS OTHERWISE SPECIFIED DIMENSIONS ARE IN INCHES. TOLERANCES ARE: .X ±.1 ANGLES ±1° .XX ±.015 SURF FINISH 125 .XXX ±.005 SURF FINISH V DO NOT SCALE DRAWING		CONTRACT NO.		<b>Atlas Vac Machine</b> PO Box 42633, Cincinnati, Ohio 45242	
THIRD ANGLE PROJECTION		APPROVALS	DATE		
MATERIAL	DESIGN	Mike	2/25/2022	DESCRIPTION <b>1830S ELECTRIC TRAY SEALER</b>	
TREATMENT	MFG	Mike	4/25/2019		
FINISH	CAD FILE NAME 5222023-SK.idw	SCALE	SIZE <b>D</b>	CAGE CODE <b>99296</b>	DWG. NO. <b>5222023-SK</b>
			SHEET		1 OF 1

DWG NO. 5222023-SK

SH 1 REV

N:\Atlas Vac Models, R&D\18-30 Dual Side Updated\5222023-SK.idw