



FUNCTIONSMITH, INC.
MANILA • GUANGZHOU

OFFICE SYSTEMS



779 Acacia Street, Octagon Industrial Estate Subdivision,
Barangay Dela Paz, Pasig City, 1600, Philippines

+632 7148-5208 | +632 8645-4284 | +632 8645-2664
+632 8645-4994 | +632 8941-2647 | +632 7753-2359

www.functionsmith.com

ALUMINUM SCREEN FRAME



3

Three thicknesses, three colors



ES-PF001

Oxidized color

ES-PF002

Matte white

ES-PF003

Charcoal gray



FUNCTIONSMITH, INC.
MANILA • GUANGZHOU

5

CONNECTION METHOD

The screen is divided into three thicknesses, K3, K4, K6
There are 5 ways to connect: K3/K4/K6/K3+K6/K4+K6



K3
32mm

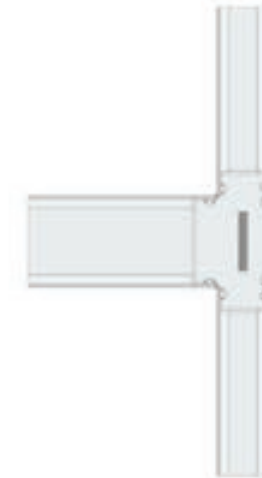

K3 +K6
32mm
+ 56mm

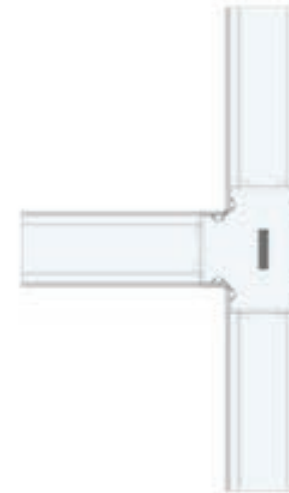

K4
42mm



K4 +K6
42mm
+ 56mm

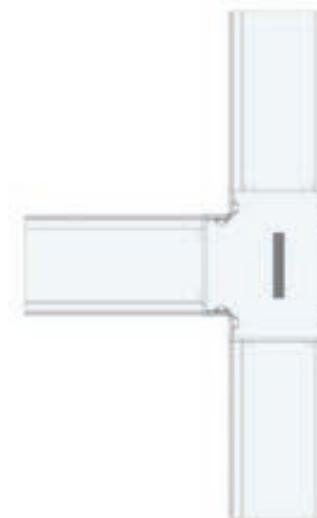

K6
56mm

USER ONE

1



Internet platform giants / New energy smart manufacturing / Life Technology / National Defense Science Day / Design and research institutions and other core R&D technical departments / Functional jobs:

"Creation": The unique creativity of knowledge workers is one of the important forces driving world progress. The core R&D strength of an enterprise will determine the company's ability to continue to grow in the future. The future competition will be the competition of technological creativity and the competition of high-end human resources. If companies do not have the ability to attract talents, how will their core competitiveness be consolidated? Corporate culture is formed by habits, but in addition to this, it is also closely related to the office environment. At present, the tide of global competition and subversion is coming from all sides. Obviously, the world is changing - and it is changing very rapidly. In addition, there is one thing that is very clear, that is, companies must maintain a "creative" mindset and promote innovation in order to survive in this environment. To achieve this goal, companies must become more agile and flexible, encourage continuous learning, and respond more quickly to new development opportunities. In the spirit of "agile creation", we have developed a variety of office methods that use space to support more creative work in core R&D technical positions. The following office product functions are the key results of these studies. These preliminary findings can not only cooperate with R&D individual and team work methods, but also support R&D personnel to adjust their body and mind during work.

- * **Hanging display device can support learning.** Whether it is a single-screen display or a digital multi-screen display, it can help R&D personnel pay attention to the overall status of the project, help arrange work and control progress.
- * **Standing position can effectively protect the healthy energy of R&D personnel working for a long time.** When a group discusses the direction of action, standing communication can deepen effectiveness and speed. This type of communication should be carried out in the main working space of R&D to isolate external interference.
- * **Concentrate on work to help sprint.** The storage space where R&D members need to assist in the execution of their work. A personal space where they can concentrate on their work is a must for R&D technicians. This space should maintain a certain degree of privacy and at the same time allow them to connect with the team. This helps to continue to advance the development project, and can increase the R&D team members' understanding of the project. Understanding
- * **Partner matching and cross-functional training can avoid progress stalls.** Letting R&D technicians work side by side in the same workspace can help team members understand each other's work. Cross-functional training can ensure that the project will not stall due to employees asking for leave.
- * **Rest can charge the team members.** The rest function allows R&D technicians to find a room to rejuvenate after completing tasks that require a high degree of concentration. Of course, some people will go to coffee shops or other social spaces to relax, but we believe that most R&D technicians prefer to have a quiet place for their own rest. Everyone's "charging" method is different, and we highly respect this difference.



1150mm
Desktop rising height
750mm





K6
A9-1-XBX
B1-1

Note: The thickness of the screen is the thickness of K6. The main screen A chooses A9-1 (with a hanging slot, applicable to all main screen A), with a small white plug under the table. Sub-screen B chose B1-1.







**K6
A9-1-XBX
B1-1**



Note: The thickness of the screen is the thickness of K6. The main screen A chooses A9-1 (with a hanging slot, applicable to all main screen A), with a small white plug under the table. Sub-screen B chose B1-1.



FUNCTIONSMITH, INC.

MANILA • GUANGZHOU



Internet platform giants / New energy smart manufacturing / Life Technology / National Defense Science Day / Design and research institutions and other core R&D technical departments / Functional jobs:



FUNCTIONSMITH, INC.

MANILA • GUANGZHOU



Internet platform giants / New energy smart manufacturing / Life Technology / National Defense Science Day / Design and research institutions and other core R&D technical departments / Functional jobs.



3X



(K4+k6) (A9-2-XBX) (B1-2) (B1-3)

Note: The thickness of the screen is the thickness of K4+K6. For the height difference, the main screen A has chosen A9-2, (with a hanging slot, applicable to all main screens A), with a small white plug under the table. Sub-screen B chooses B1-2 and B1-3 (clear glass).







K3+K6
A6-1-XBX
B1-3

Note: The thickness of the screen is K3+K6 thickness. The main screen A chooses A6-1 (with a hanging slot, applicable to all main screens A), with a small white plug under the table. B1-3 (frosted glass) is selected for the secondary screen B.

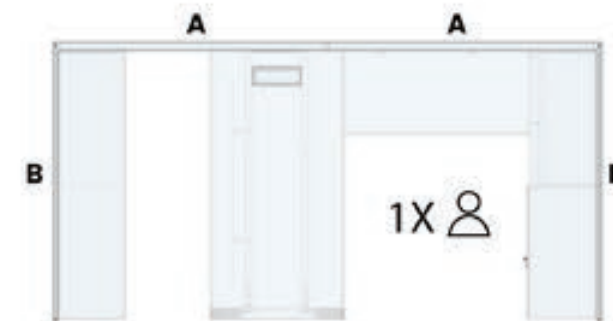





K6
A9-2-XBX
B1-2

Note: The thickness of the screen is the thickness of K6. The main screen A chose the A9-2, table with a small white plug. Sub-screen B chooses B1-2.



6X

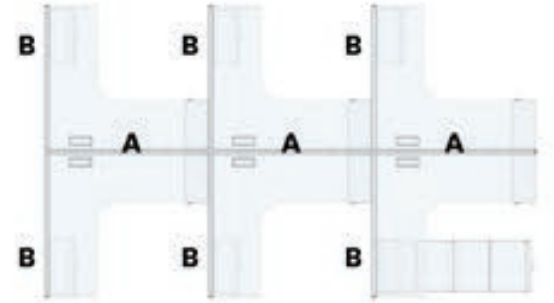



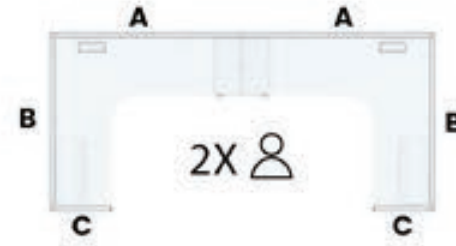

K6
A9-2-XBX
B1-2
C1-2

Note: The thickness of the screen is the thickness of K6. The main screen A chose A9-2, with a small white plug under the table. Sub-screen B chooses B1-2, and side screen C chooses C1-2.





FUNCTIONSMITH, INC.

MANILA • GUANGZHOU

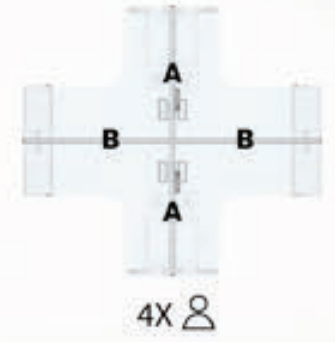

(K6)(A7-1-XBX-86X)(B1-1)

Note: The thickness of the screen is the thickness of K6. The main screen A chooses A7-1 (with a hanging slot, applicable to all main screens A), a small white plug and 86 socket under the table, and B1-1 for the secondary screen B.



FUNCTIONSMITH, INC.
MANILA • GUANGZHOU

2

State-owned enterprises and institutions, mature enterprise organizations, large group companies, universal jobs:

"Synergy": The boundary of business operation is determined by the collaboration of the team. Breaking the internal "departmental wall" boundary is an important starting point for collaborative customers to achieve results. In the era of open source, collaborative corporate customers and supply chain partners have become important resource forces that connect with the strong. Together we will be stronger. Employees who trust each other and are good at cooperation are the greatest wealth of an enterprise. We fully consider the relationship between contract subjects and form an effective system guarantee. Respect for knowledge, respect for individuality, collective struggle, and employees who are meritorious, are the growth of our business. Intrinsic requirements: Loving yourself, loving colleagues, loving career and loving life are the source of our cohesion. Management flexibility, system de-control, project team system, organization decentralization: sense of responsibility, innovation spirit, dedication and unity and cooperation spirit are the essence of corporate culture. The organizational form of office furniture determines the strength of the company's "synergy". When we transform office furniture from product attributes to tool attributes, we must discover how the kinetic energy of "people" in a fixed space can produce more effective collaboration. To become the most important tool carrier, the collaboration of people, space, and tools will inevitably produce greater value. Which product solution, "Open Staff Desk" or "Screen Staff Desk", can better balance the synergy of corporate organization operations? We suggest that state-owned enterprises and institutions, mature enterprise organizations, and large group companies use "screen staff desks" to be more collaborative.

USER TWO





FUNCTIONSMITH, INC.

MANILA • GUANGZHOU



State-owned enterprises and institutions/mature enterprise organizations/large group companies/universal jobs

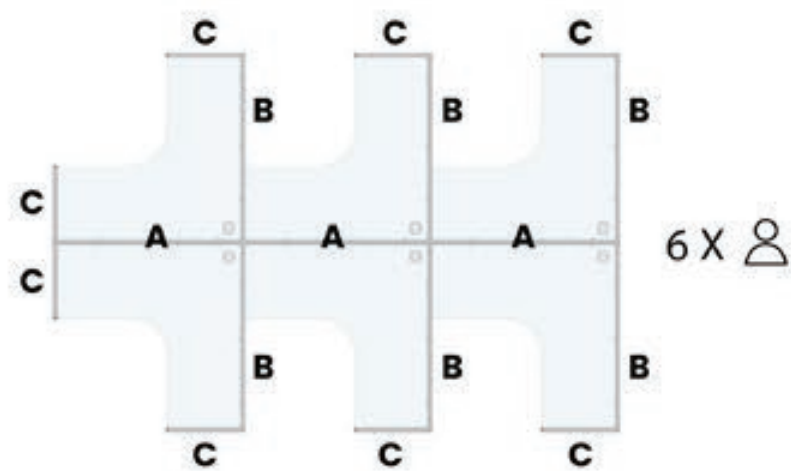

K3
A1-3-86X
B1-3
C1-3

Note: The thickness of the screen is the thickness of K3, the main screen A has chosen A1-3, and there are 86 sockets under the table. Choose B1-3 for secondary screen B and choose C1-3 for side screen C (striped frosted glass).



4X

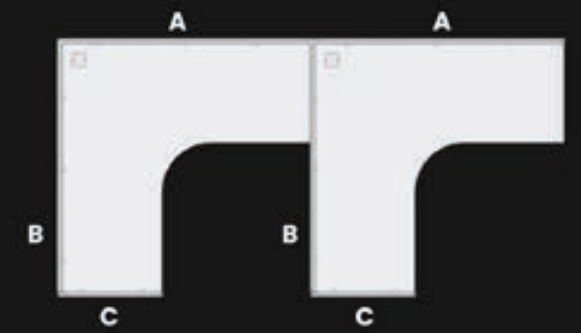

K3
A1-1-86X
B1-1
C1-1

Note: The thickness of the screen is the thickness of K3, with a height difference. The main screen A has chosen A1-1, with 86 sockets under the table. Sub-screen B chooses B1-1 and side screen C chooses C1-1.





K3
A6-1-XBX
B1-1

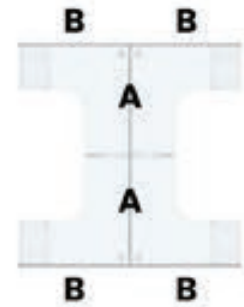

Note: The thickness of the screen is the thickness of K3, the main screen A chooses A6-1 (with hanging slot, all main screen A with hanging slot is applicable), with a small white plug on the table. Sub-screen B chose B1-1.

4 X 



FUNCTIONSMITH, INC.

MANILA • GUANGZHOU



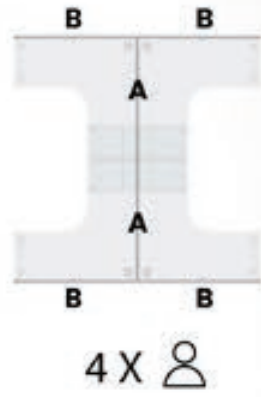

K3
A1-3-86X ———
B1-3

Note: The thickness of the screen is the thickness of K3, the main screen A chooses A1-3 (frosted glass), with 86 sockets under the table. B1-3 (clear glass) is selected for the sub screen B.





FUNCTIONSMITH, INC.

MANILA • GUANGZHOU



K3
32mm



K4
42mm



K6
56mm



State-owned enterprises and institutions/mature enterprise organizations/large group companies/universal jobs

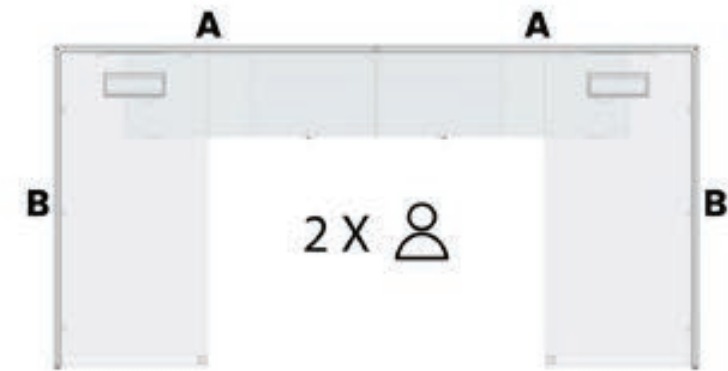

K3
A8-2-XBX-86X
B1-2

Note: The thickness of the screen is the thickness of K3. Main screen A chooses A8-2 (with hanging slot, applicable to all main screen A) with A small white plug on the table. There is 86 socket under the table, and B1-2 is selected for secondary screen B.



FUNCTIONSMITH, INC.

MANILA • GUANGZHOU

State-owned enterprises and institutions/mature enterprise organizations/large group companies/universal jobs



K3
A1-2-86X
B1-2

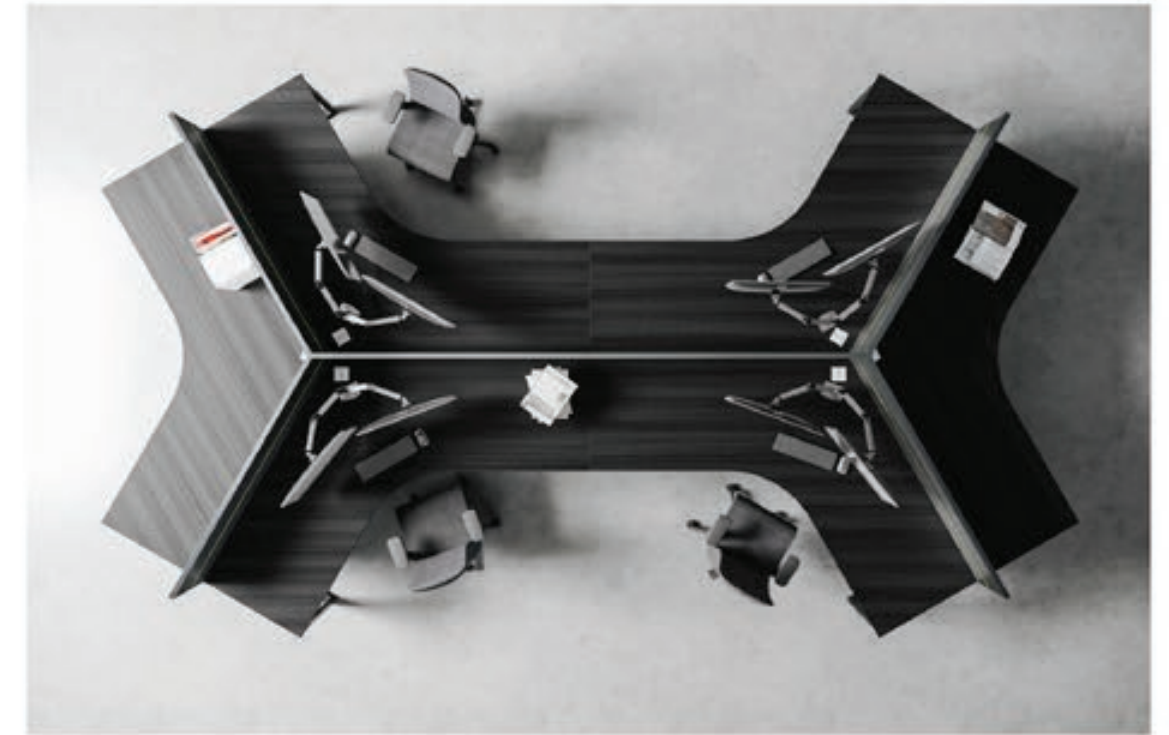
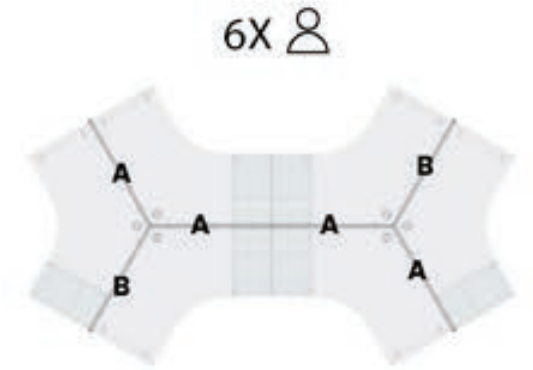

Note: The thickness of the screen is the thickness of K3. The main screen A chooses A1-2, (with hanging slots, the main screen A is suitable) with 86 sockets under the table. Sub-screen B chooses B1-2.



(K3) (A1-3-86X) (B1-3)

Note: The thickness of the screen is the thickness of K3, the main screen A has chosen A1-3, and there are B6 sockets under the table. B1-3 (striped frosted glass) is selected for the secondary screen B.

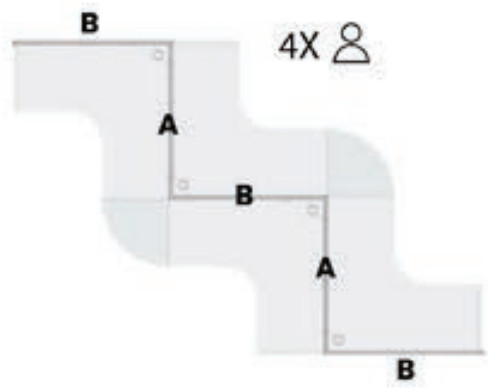



FUNCTIONSMITH, INC.

MANILA • GUANGZHOU





FUNCTIONSMITH, INC.

MANILA • GUANGZHOU

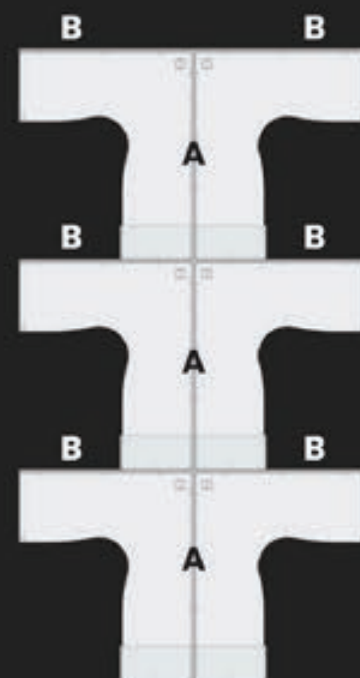

6 X 

K4
A7-1-XBX-86X
B1-2

Note: The thickness of the screen is the thickness of K4. The main screen A chooses A7-1 (with hanging slots, applicable to all main screens A) with a small white plug and 86 socket under the table, and the sub screen B chooses B1-2.





K4
A1-3-86X
B1-3

Note: The thickness of the screen is the thickness of K4, the main screen A chooses A1-3, and there are 86 sockets under the table. B1-3 (frosted glass) is selected for the secondary screen B.





FUNCTIONSMITH, INC.

MANILA • GUANGZHOU

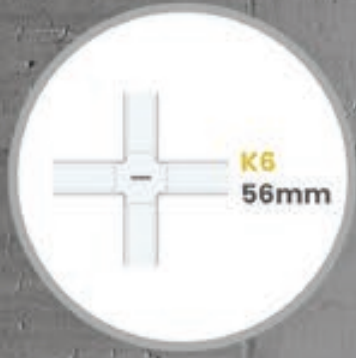

State-owned enterprises and institutions/mature enterprise organizations/large group companies/universal jobs



K4
A1-3-86X
B1-3

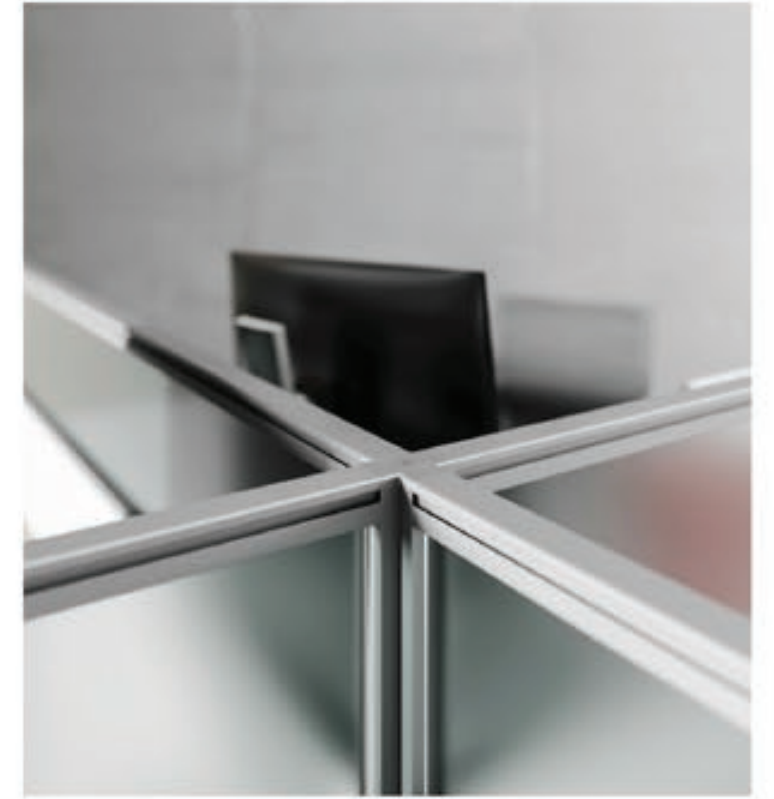

FUNCTIONSMITH, INC.
 MANILA • GUANGZHOU

Note: The thickness of the screen is the thickness of K4. The main screen A chooses A1-3, the table has 86 sockets, and the auxiliary screen B chooses B1-3 (clear glass).



FUNCTIONSMITH, INC.

MANILA • GUANGZHOU



State-owned enterprises and institutions/mature enterprise organizations/large group companies/universal jobs



K3+K6
A1-2-XBX
B1-3

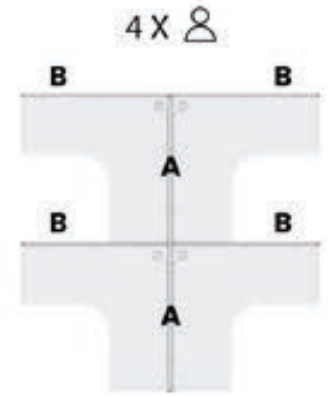

Note: The thickness of the screen is the thickness of K3+K6, with a height difference. The main screen A chooses A1-2, (with a hanging slot, the main screen A is applicable), with a small white plug under the table. B1-3 (frosted glass) is selected for the secondary screen B.





FUNCTIONSMITH, INC.

MANILA • GUANGZHOU



State-owned enterprises and institutions / mature enterprise organizations / large group companies / universal jobs

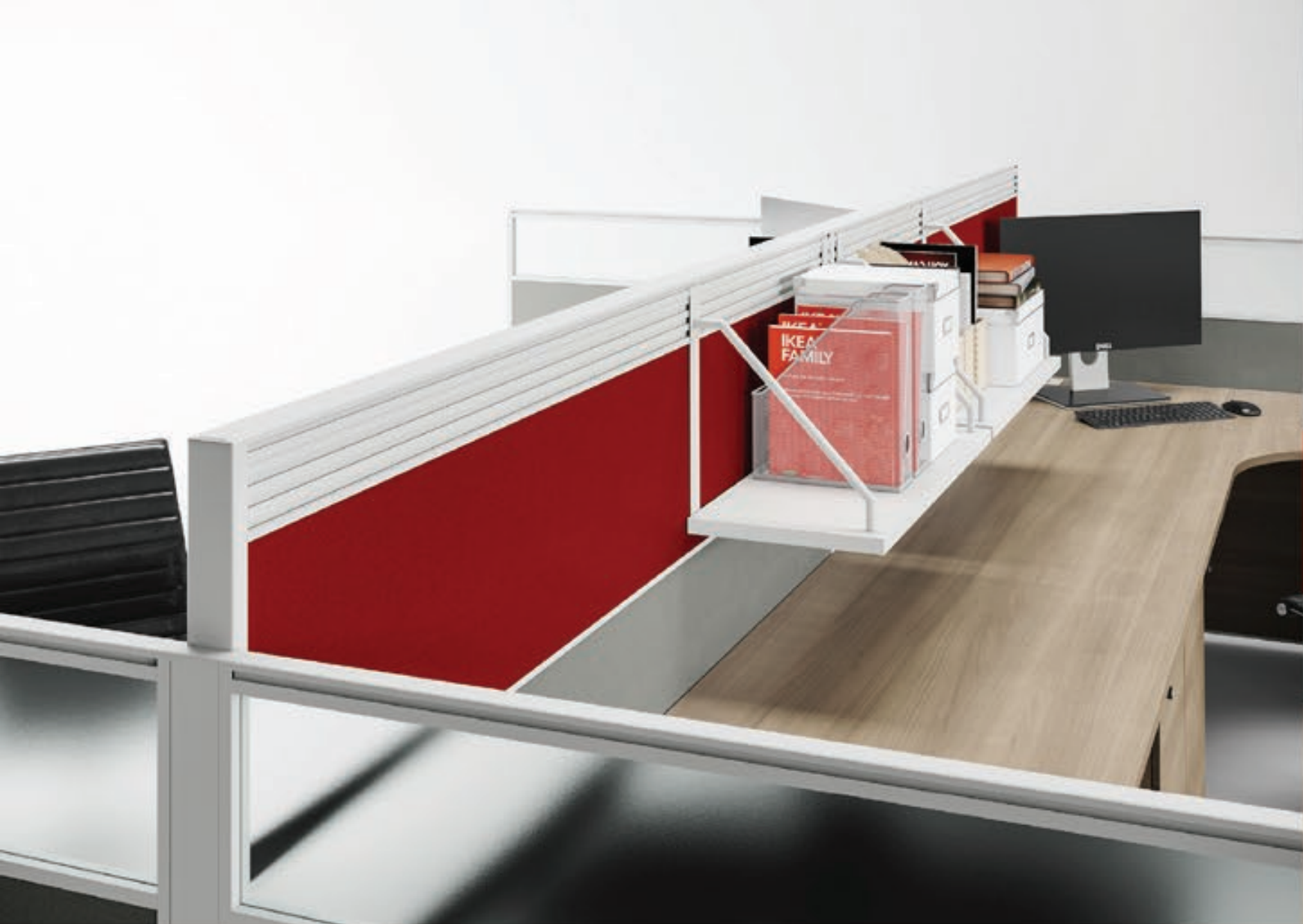

K3+K6
A1-2-XBX
B1-3

Note: The thickness of the screen is the thickness of K3+K6, with a height difference. The main screen A chooses A1-2, (with a hanging slot, the main screen A is applicable), with a small white plug under the table. B1-3 (frosted glass) is selected for the secondary screen B.

4X





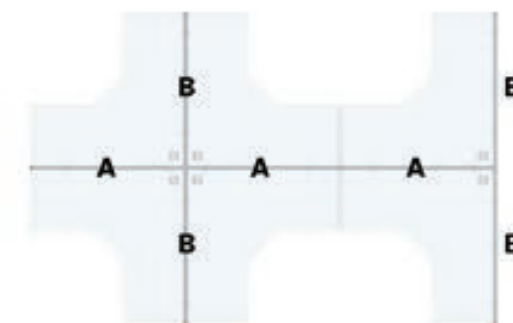

6X 

K4+K6
A1-3-86X
B1-3

Note: The thickness of the screen is the thickness of K4+K6, the main screen A has chosen A1-3, and there are 86 sockets under the table. B1-3 (striped frosted glass) is selected for the secondary screen B.



FUNCTIONSMITH, INC.
 MANILA • GUANGZHOU



FUNCTIONSMITH, INC.
MANILA • GUANGZHOU

3

General clerical, customer service, technical support, and simple jobs:

"Efficiency": How to ensure that the work of ordinary employees in the company is efficient? This has become the biggest problem for business management in the new century. The essence of management is to transform knowledge into productivity. However, the productivity of today's knowledge workers is as low as that of manual workers in the 19th century. Peter Drucker wrote 'Management Challenges in the 21st Century' in 1999 and commented that the most important, practical and truly unique contribution of management in the 20th century is to increase the productivity of manual workers in the manufacturing industry by as much as 50 times. In the 21st century, the most important challenge that management needs to make is how to improve the productivity of knowledge workers. We affirm that effective organization and management, corporate culture, and team atmosphere are the decisive factors for improving efficiency, but at the same time, the value of tools must not be ignored. Office furniture is the most direct territory for each employee's work efficiency. How to provide matching Office furniture products that meet the work demands of ordinary employees? This requires us to have insight and thinking from the perspective of employees. 'Open staff desk' and 'screen staff desk' are essentially tools that serve employees' work efficiency. We recommend that more employees participate in the selection of which tool is more suitable. Wise decision-making will increase the work efficiency of employees, and the return will be much higher than the value of office furniture itself. This will be the most rational investment thinking for business management.

USER THREE





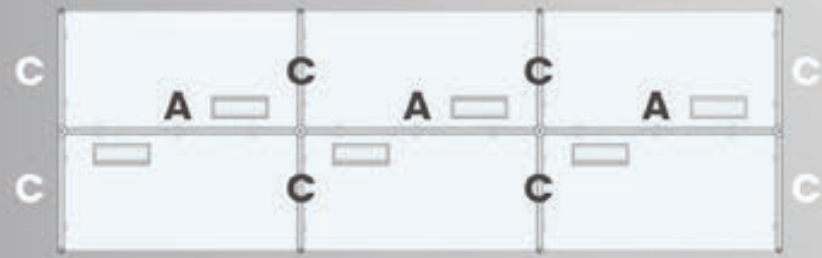

6 X 

(K3) (A7-1-XBX-86X) (C1-1)

Note: The thickness of the screen is the thickness of K3. The main screen A chooses A7-1, the table has a small white plug, the table has 86 sockets, and the C side screen chooses C1-1.



FUNCTIONSMITH, INC.

MANILA • GUANGZHOU



FUNCTIONSMITH, INC.

MANILA • GUANGZHOU



General clerical job, customer service, technical support, simple job positions



(K3) (A7-1-XBX-86X) (C1-1)

Note: The thickness of the screen is the thickness of K3, the main screen A chooses A7-1 (with hanging slots, all main screen A is applicable), the table has a small white plug, and the table has 86 sockets, and the C side screen chooses C1-1.



FUNCTIONSMITH, INC.
MANILA • GUANGZHOU





8X 



(K3) (A1-1-86X) (C1-1)

Note: The thickness of the screen is the thickness of K3. The main screen A chooses A1-1, the table has 86 sockets, and the C side screen chooses C1-1.



FUNCTIONSMITH, INC.

MANILA • GUANGZHOU



General clerical job, customer service, technical support, simple job positions



4 X 



(K3) (A1-3-86X) (C1-3)

Note: The thickness of the screen is the thickness of K3. The main screen A chooses A1-3 (clear glass), the table has 86 sockets, and the C side screen chooses C1-3 (frosted glass).



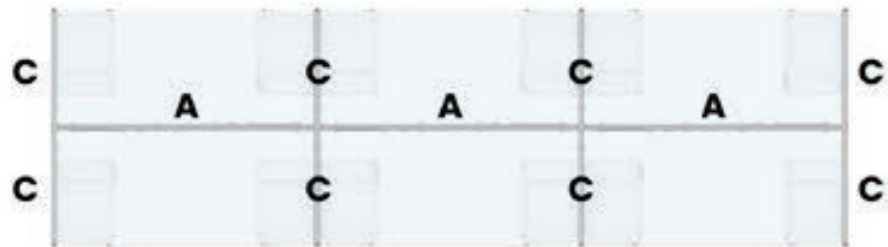

6X 

(K3) (A8-2-XBX-86X) (C1-2)

Note: The thickness of the screen is the thickness of K3, the main screen A chooses A8-2 (with hanging slots, all main screen A is applicable), the table has a small white plug, 86 sockets under the table, and the C side screen chooses C1-2.



FUNCTIONSMITH, INC.

MANILA • GUANGZHOU



General clerical job, customer service, technical support, simple job positions



12 X 



(K3) (A1-2-86X) (C1-2)

Note: The thickness of the screen is the thickness of K3, A1 is selected for the main screen A, with a line board under the table, and C1 is selected for the C side screen.





2X 



(K3) (A2-1-86X) (C1-1)

Note: The thickness of the screen is the thickness of K3, the main screen A chooses A2-1 (with hanging slots, all main screen A is applicable) with 86 sockets under the table, and the C side screen chooses C1-1.



FUNCTIONSMITH, INC.

MANILA • GUANGZHOU



General clerical job, customer service, technical support, simple job positions

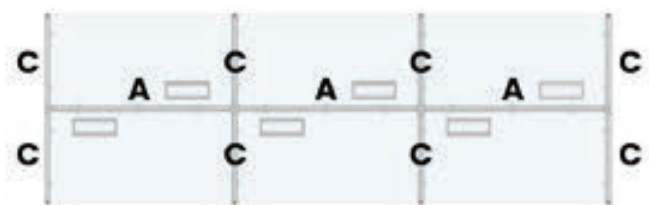

(K4) (A2-2-86X) (C1-3)

Note: The thickness of the screen is the thickness of K4. The main screen A chooses A2-2, the table has 86 sockets, and the C side screen chooses C1-3 (clear glass).

6X







(K4) (A9-2-XBX)

Note: The thickness of the screen is the thickness of K4, the main screen. A chooses A9-2 (with hanging slots, applicable to all main screen A), with a small white plug under the table.







6X 



FUNCTIONSMITH, INC.
MANILA • GUANGZHOU

K3+K6
A8-3-XBX-86X
C1-3

Note: The thickness of the screen is K3+K6. The main screen A chooses A8-3 (frosted glass), the table has a small white plug, and the table has 86 sockets, and the C side screen chooses C1-3 (clear glass).







6X 



K3+K6
A8-2-XBX-86X
C1-1

Note: The thickness of the screen is the thickness of K3+K6. The main screen A chooses A8-2, (with a lift-door wall cabinet, the main screen A can be installed), with a small white plug on the table and 86 sockets under the table. The C side screen chose C1-1.





FUNCTIONSMITH, INC.

MANILA • GUANGZHOU



General clerical job, customer service, technical support, simple job positions



4X 

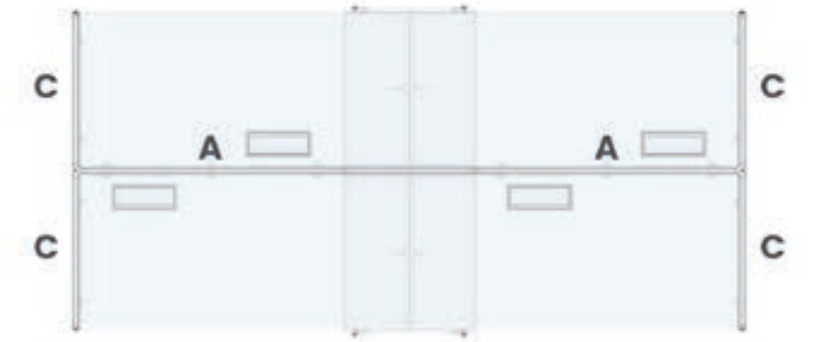

**K4+K6
A1-2-86X
C1-2**

Note: The thickness of the screen is the thickness of K3. The main screen A chooses A1-2, the table has 86 sockets, and the C side screen chooses C1-2.



FUNCTIONSMITH, INC.

MANILA • GUANGZHOU

Screen routing position and separation

Screen specifications

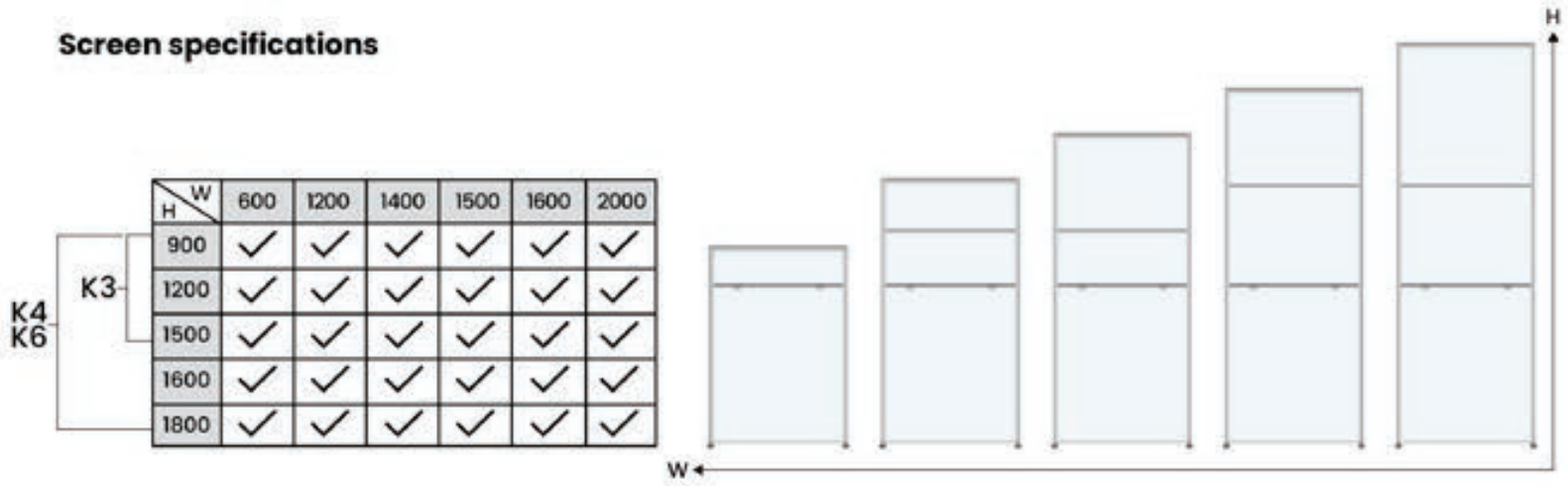

A main screen (Wire board installation position)

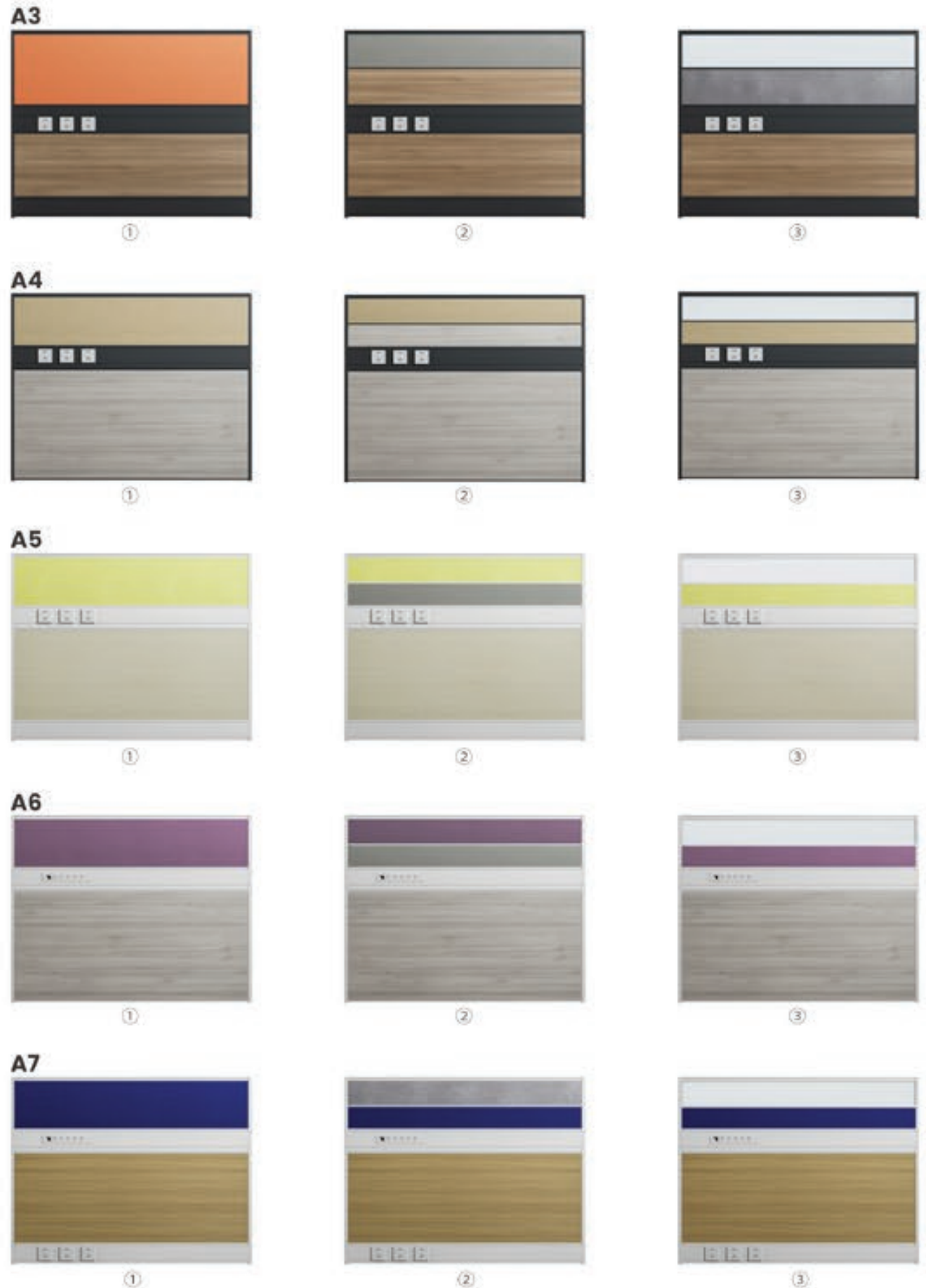
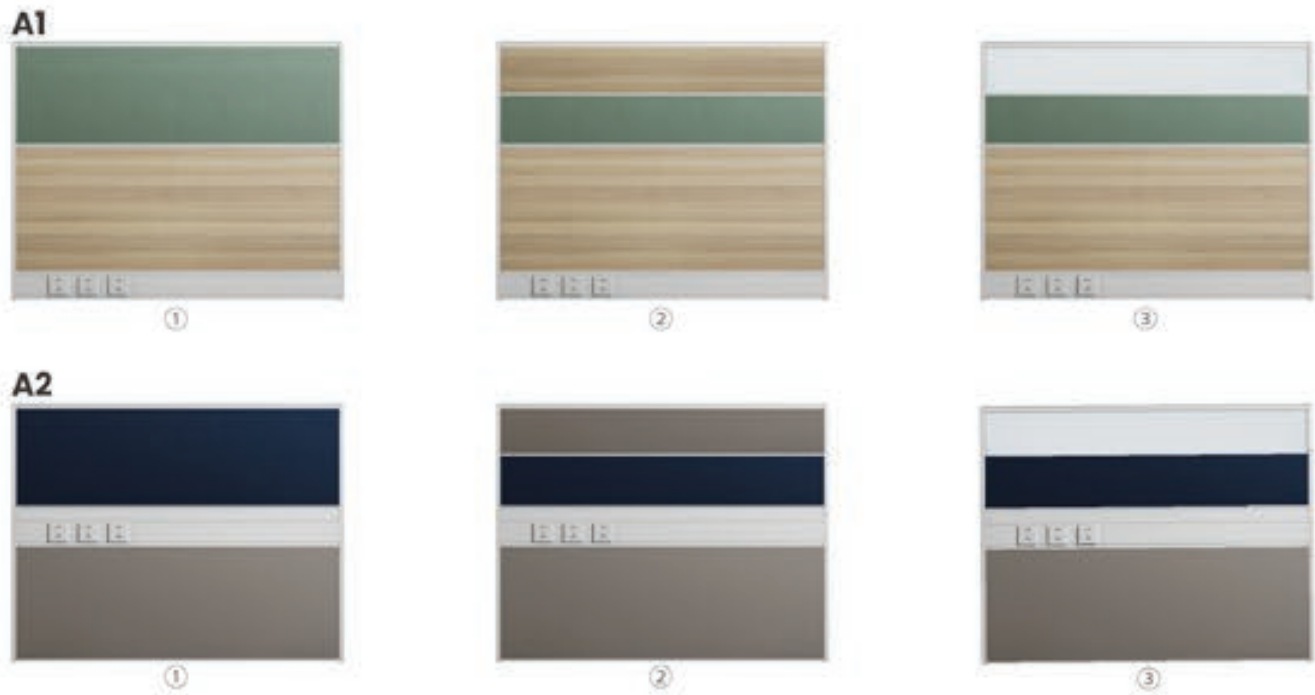

A8



A9



B sub screen

B1



B2



C side screen

C1



C2

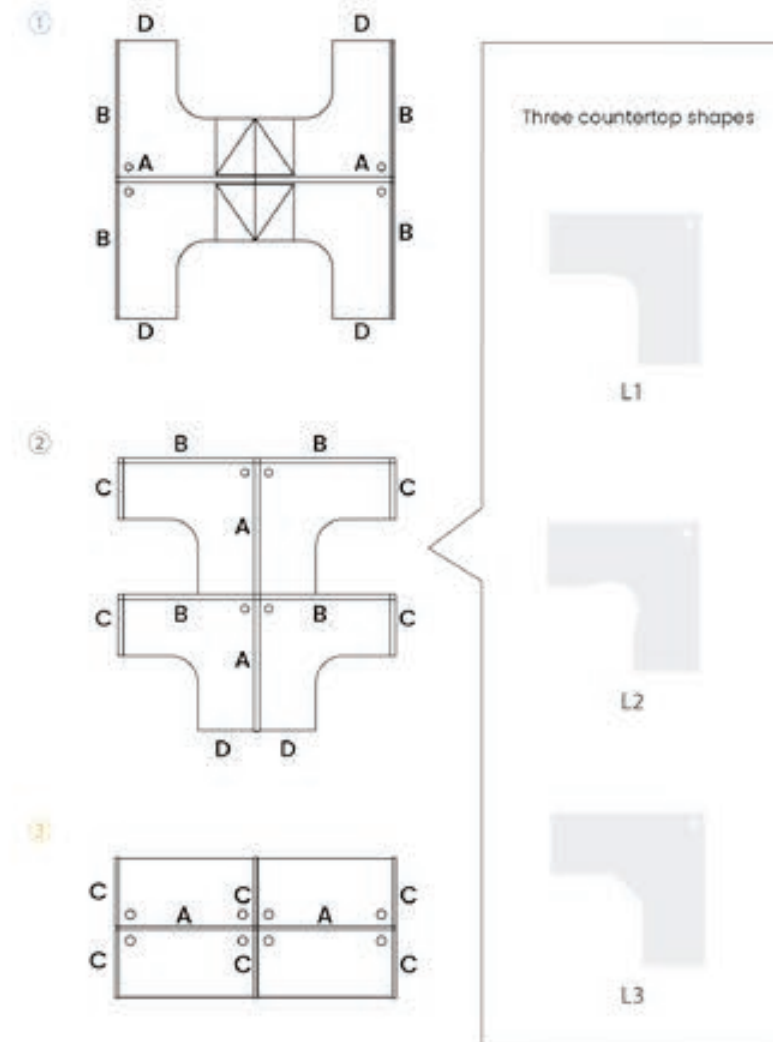

- ① Large workstations: functional office furniture jobs in the core R&D technical department (USER ONE).
- ② L-type workstations: enterprises and institutions, universal jobs (USER TWO).
- ③ Straight work positions: simple and simple work positions for general clerical work, customer service, and technical support (USER THREE).

A main screen
 B sub screen
 C side screen
 D support foot



Three styles of glass



Striped frosted glass



Clear glass



Frosted glass

Stitching close-up



Type T



Type L

Screen close-up

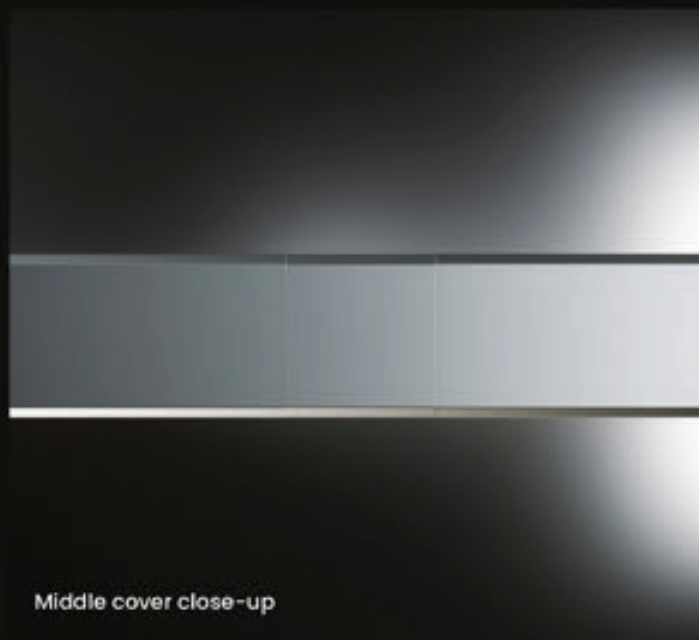

Middle cover close-up

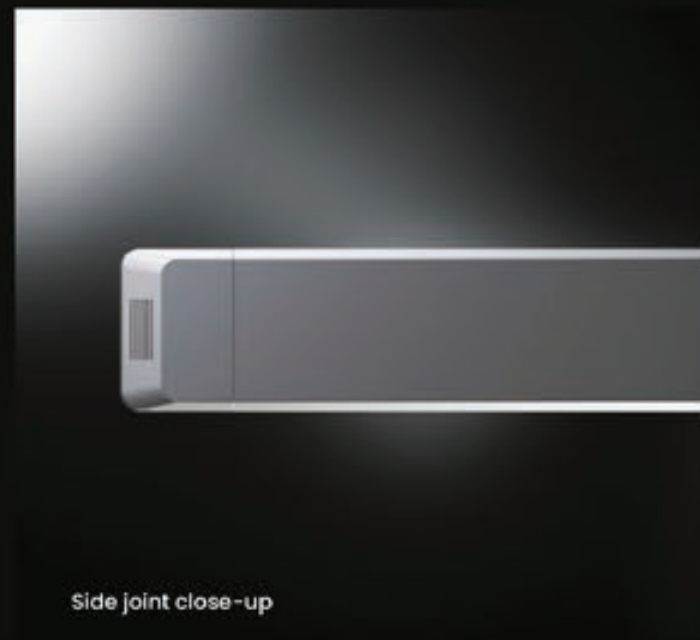

Side joint close-up



Type 120 °

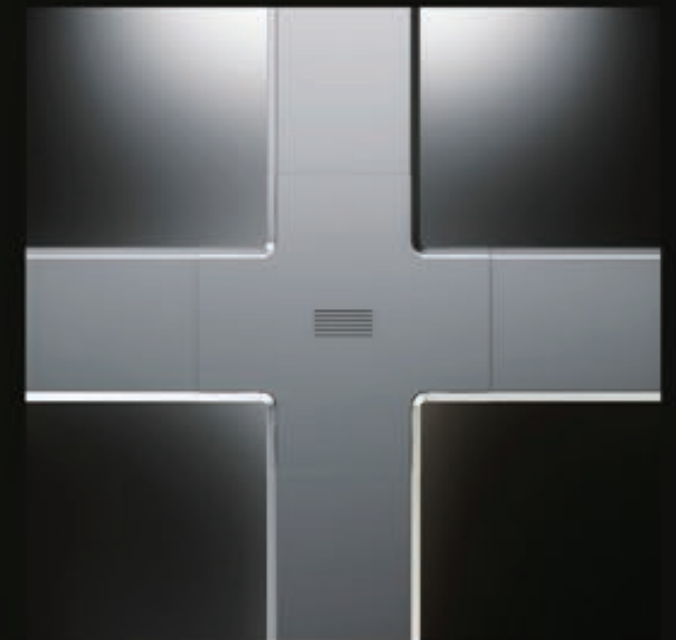

Cross type

Support foot D selection



Line board position

7 types of support feet



D1



D2



D3



D4



D5



D6



D7



SCREEN LINE ROUTING

XBX



86X



XBX 86X



86X



86X

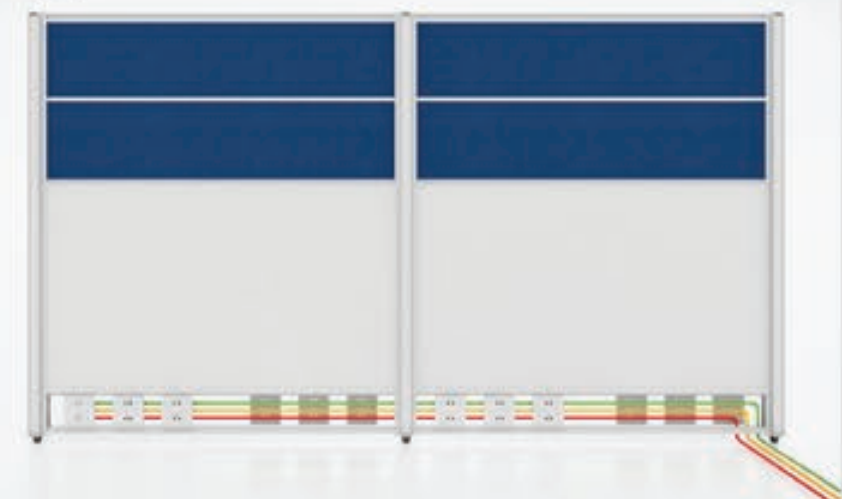

XBX 86X



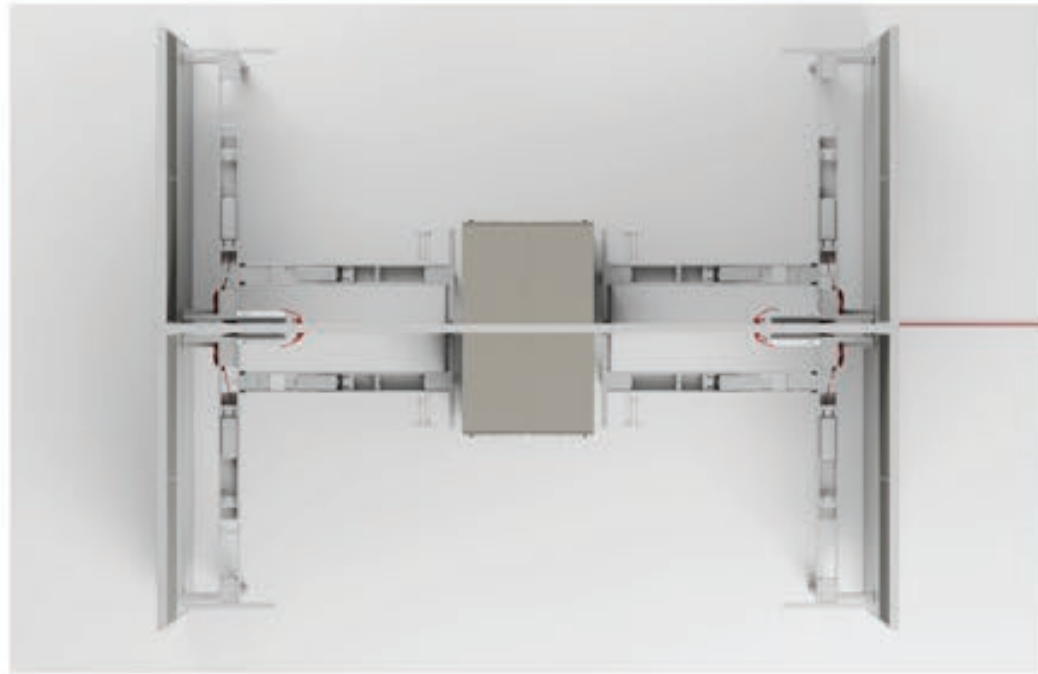

LARGE STATION LIFTING LINE



From the bottom of the screen, go through the main screen and connect with the small white plug. The design of the retractable line allows the power consumption of the lifting table to be extended.



The desktop small white plug through the wire and the table bottom small white plug-in cable, which is convenient for desktop power consumption.



The line goes online through the bottom of the screen



The line is installed