



**ROCHESTER
GAUGES, INC.**

ISO 9001:2008 CERTIFIED

Magnetic Liquid-Level Gauges

**8600
Series**

Magnetic Liquid-Level Gauges

Application

The 8600 Series Senior™ spiral gauges are designed for use in measuring liquid levels in hydraulic, lubricating or fuel-oil storage tanks, and gasoline and diesel fuel levels in stationary, standby and mobile generators. The 8600 Series is not recommended for off-road equipment.

General Information & Features

The 8640 spiral gauge incorporates a strong Alnico magnet capable of driving a TwinSite™ sender which provides a direct, fractional reading and also sends an electrical signal to a remote receiver.

The 8660 spiral gauge is supplied with an easy to read, side-view fractional dial. The model 8680 spiral gauge is equipped with a standard top reading fractional dial.

All 8600 Series spiral gauges have a 1 1/2" MNPT tank connection and are suitable for tank pressures up to 25 psig maximum. They are designed for top mounting in tanks up to 36" deep and some models are UL listed for flammable liquids.

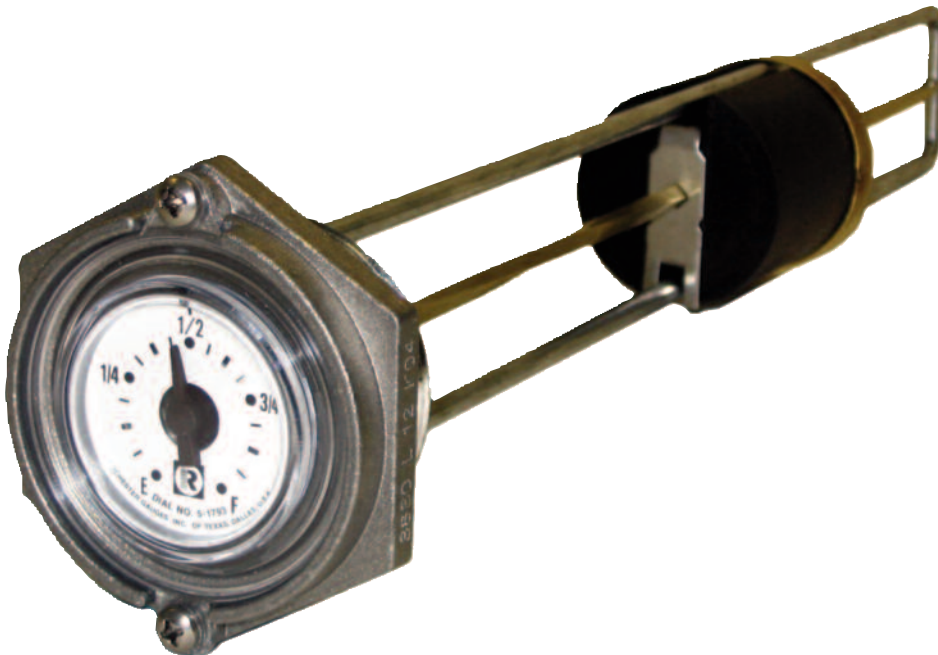

Model #	Sender or Dial Type
8640	Senior TwinSite™ Sender in choice of 0-30, 0-90, or 240-30 Ohm ranges. Specify your preference when ordering.
8660	#5025S00570 Senior™ side-reading fractional dial.
8680	#5844S01793 Senior™ direct-reading fractional dial.

08/26/10

See reverse side for dimensional data, materials of construction, performance, and advice on how to order.

The Measure of Excellence

[METRIC]

Senior TwinSite™ Sender (Specify ohm range)

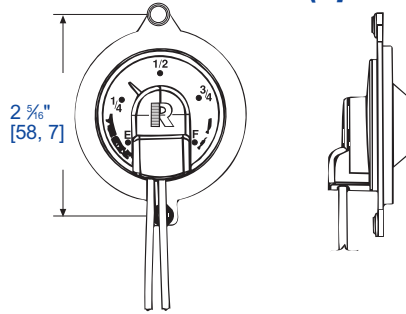

Senior Dial

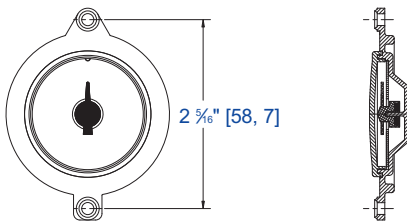

Senior Side-Reading Dial

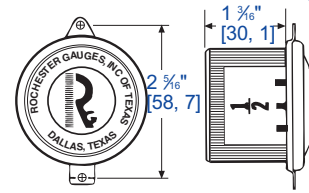

Standard Construction

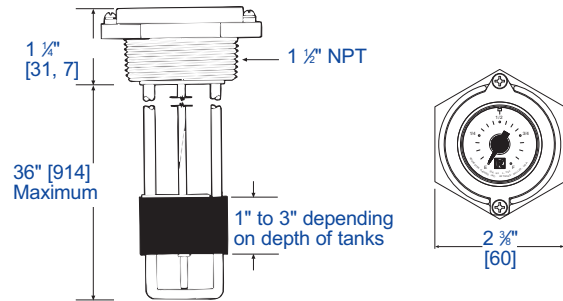

General Specifications*

Mounting

Designed for top-mounting only.

Repeatability

Repeatability depends on proper gauge sizing & tank configuration. Normally, standard dials are $\pm 7\%$; side-reading dials are $\pm 8\%$; & TwinSite™ senders are $\pm 12\%$. Vibration improves repeatability.

Temperature

Standard operating range is -40°F to 158°F , -40C to 70C .

Humidity

Exposed portion should be painted for marine applications, less dial.

Shock

Shorter sizes are suitable for some mobile, off-road application.

Vibration

Shorter sizes are suitable for some mobile, off-road application.

Power

0.5 watts maximum for TwinSite™ versions.

Tank Pressure

0 to 25 psig [0 - 1, 7 Bar] maximum.

Approval

Direct indicating gauge. Available UL listed for flammable liquids. Some models UL recognized for marine service.

Materials of Construction*

Head

Die-cast zinc.

Guide Rod

Zinc-plated steel.

Centershaft

Brass.

Tie Plate, Guide & Bearing Pin

Stainless steel.

Float

Nitrile rubber.

Drive Magnet

Alnico.

Standard Dial

Polycarbonate, hermetically sealed.

Side-View Dial

Aluminum with polycarbonate crystal, hermetically sealed.

TwinSite™ Sender

Polyamide.

* Materials and specifications are subject to change without notice. Pressure ratings subject to change due to temperature and other environmental considerations.

When ordering, specify:

1. Gauge model number.
2. Tank height.
3. Ohm range on TwinSite™ versions.
4. Riser height, if any.
5. Any special requirements.

08/26/10