

BLACKSMITHING



Introduction

Blacksmithing transforms metals in its physical structure and appearance by heating and hammering.

In this brief, materials are restricted ferrous metals, that is, the range of irons and steels.

The smithy contains five main things to aid the blacksmith in their work. There needs to be a heat source or hearth to get the material red hot to be able to mould it. There must be a cooling system close to hand, not only for quenching material when it has been worked, but also as a safety aspect in case of embers rising/ or burning taking place while the blacksmith is working.



Figure 1: The Azagarafa Blacksmith Society of Azagarafa village in the North Darfur region of Sudan. Photo: Practical Action.

Experience is critical to the skilled smith: skills still require practise.

The essentials for blacksmithing are:

- A means of heating.
- A means of rapid cooling.
- Support for the work pieces.
- Shaping and deforming implements.
- Work material.

Heating

A form of heating hearth or forge is needed in which a fire can be maintained. Forced air will be required to assist in the generation of sufficient heat for workpieces to reach at least forging temperature, say 1000 °C and preferably welding heat which is another 100/2000 °C higher depending on the materials involved.

The hearth can be formed by a stone or brick structure or a metal table structure. A hood or chimney is required when the hearth is indoors.

Ideally, the hearth should be at least 2m (6') deep and 2m (6') wide. The hearth needs a strong stone slab or iron plate along the working ledge which should be a little lower than domestic table height from the ground, a tall smith would benefit from having this height increased still further so as to reduce fatigue.

Traditionally bellows are used to supply air piped through the left hand side of the furnace, if the smith is right handed, through an iron tube.



Figure 2: A man working his forge blower.

Photo credit: Zul / Practical Action.

A pair of bellows or, more recently, an air fan, needs to be fitted into the forge via iron tubes, to allow air to be blown into the fire. Quite sophisticated tubes exist in some countries: English smiths have water-cooled ones traditionally called tueirons. Alternatively, ceramic tubes can be used without a cooling system. There are various types of fan,

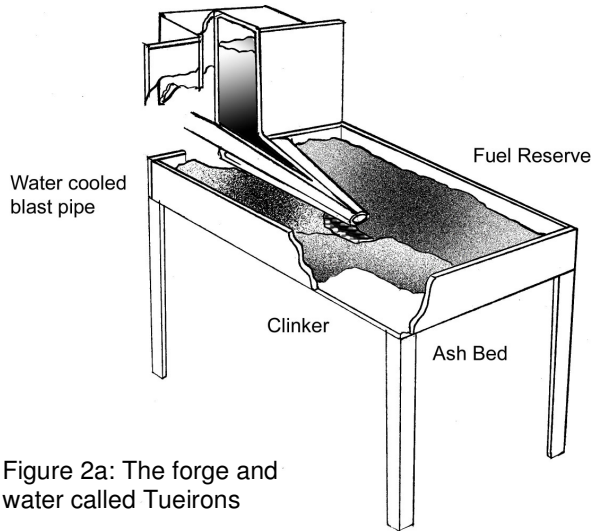

Figure 2a: The forge and water called Tueirons

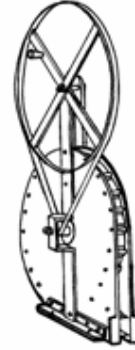

Figure 2b: The blower

The traditional bellow and some crank fans require manual input; another option is an electric fan where available.

The heating medium can be charcoal if clean walnut-size gas coke is not available. If coke is used always screen it first by using a fine mesh riddle so as to separate coke dust and physical impurities, which may have become mixed with the fuel. Always keep the fire free from clinker: as soon as the essential heating area becomes too hot, clinker is formed and this needs carefully removing with the aid of a poker without losing the fire altogether. Most smiths-suspend a coke guard over the arch of the hearth, which also helps to improve natural draught slightly.

Cooling and Quenching

The water trough – As mentioned earlier it is important to have a bucket or trough close at hand not only for quenching but also in case of burning. So the main use for the water is to quench the hot steel to cool or temper it. The bucket should be large enough to totally immerse all pieces of work easily. The volume of the trough should be at least 25 litres (5 Gallons UK) so this is possible.

The oil container – This container should be about the same size as the trough as it will be used for the same material, which needs to be quenched. The important thing to note about oil and therefore the design of the oil container is that the oil can some times catch fire. Because of this the container should have a hinged lid, which can be shut depriving the flames of oxygen should the oil catch fire. (Fire only usually occurs when there is insufficient oil and so it is heated up and begins to burn)

The container holding the oil should be situated in a separate place, either outside or somewhere else in the smithy. It should not be situated by any other combustible objects. It is important to note that the forge and oil container should both be surrounded by metal flooring, not wood, in case hot coals are dropped or flash fires occur.

Support for working material

Anvil

An anvil of some kind is essential equipment and whilst one of many varieties could be selected, it is probable that an improvised anvil made of stone with an iron insert might suffice in an emergency. Some anvil patterns are illustrated below, see figure.



Figure 3a: Blacksmiths. Photo credit: Practical Action / Tim Reeves



A typical anvil

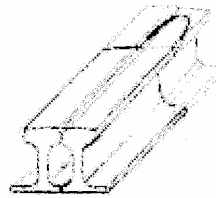

Old rail tracks

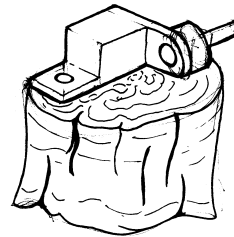

An improvised anvil made from an old casting

Figure 3b: Different types of Anvil layouts

Shaping/ Deforming Tools

All tools to deform malleable iron or steel consist of clams, hot and cold sets, various tongs for handling the work piece and, of course, hammers. These are illustrated as follows,

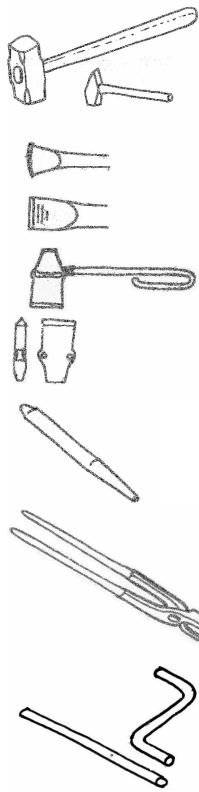

Sledge Hammer – Very Heavy hammer usually used by the blacksmiths assistant to work the large pieces of metal.

Cross Peen Hammer – Smaller hammer with two ends for different effects. Used in most forging processes.

Hot Chisel – Used for cutting hot metal, by striking with a hammer. This tool is not hardened and should not be used to cut cold material, only heated.

Cold Chisel – Used to cut cold material, never hot material. This tool is hardened and tempered so it is sharp and strong so it can cut cold material.

Hot set – Similar to a chisel but with a long handle. It is usually struck by a sledgehammer operated by the blacksmiths assistant. Not for cold material.

Cold set – This is used for cold material as the name suggests. It again has a long handle like the hot set. Again it is struck by a sledgehammer. The cold set looks similar to the hot set apart from its thickness and angle of blade.

Round Punch – Creates a round hole by driving the punch through a sheet of hot material. Alternative to the drill.

Tongs – Used to hold material when it has been heated and is ready for work. These can be made in the forge, for different pieces of work. The heads can be shaped to grip different sizes and shapes of material.

Bottom Fuller – Normally used with a top filler, to create rounds or indents in material.

Top Fuller – Used to make grooves in hot metal. Both the top and bottom fuller can be made from mild steel.

Figure 4: Tools Required

Mechanical Tools

There are many varieties of mechanical tools, which might be useful amongst which are; a fly-press, drilling machine, drop hammers and tilt hammers can be used, powered by a motor or water

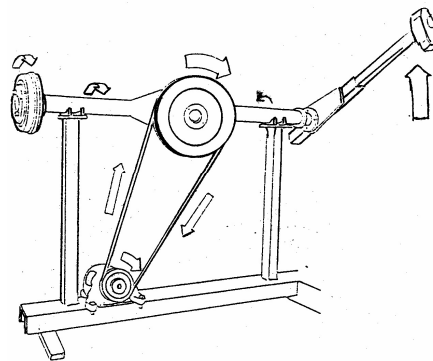

Figure 5: A mechanical tilt hammer using old car components.

Work Materials

The majority of material used by blacksmiths is that obtained from scrap yards and old cars. Sometimes materials may be bought in but often it is not necessary, as there are other materials, which can be reused.

Mild Steel – Can be found in sheet form in car body panels, truck chassis and oil drums. In bar form mild steel appears in reinforcing rods on construction sites, although these often have a slightly higher carbon content than true mild steel. You make hoes and hinges from sheet steel and tongs, set handles and sickles (toothed pattern), from bars.

When working mild steel it should be forged at a bright yellow heat as seen in the shade (just below the temperature where it starts to give off sparks) Some minor bending and cutting can be done cold. It is not possible to harden mild steel enough for cutting tools (high carbon steel is better for this) but it is easier to fire weld than other materials.

Medium Carbon Steel – Many vehicle parts and mechanical machine parts are made from medium carbon steel. Vehicle shafts, tractor plough discs and plough mould boards are a few but there are others. You can use medium carbon steel for Hoes and punches similar to mild steel, but also Hammers and hot chisels, for when you are making new tools for specific jobs.

Working medium carbon steel needs to be done at a temperature lower than that of mild steel, but still at a heat where it is yellow. The extra carbon in the steel means that it is possible to harden it but not to the extent of high carbon steel. It can be difficult to fire weld, but with practice it is possible.

High Carbon Steel – Sources of high carbon steel can be found in the following, Suspension coil spring, torsion bar, vehicle leaf spring, Anti roll bar, Wood Saw, Large hacksaw. As it is high carbon it can be hardened as mentioned before and so is very useful to make tools from when working in the forge. Tools like cold chisels, cold sets, knives, wood chisels, plane blades, axes, adzes, wood and stone carving tools and tin snips.

High Carbon steel is the most useful of the three steels described. It can be hardened, which means it is suitable to make cutting blades from, which a lot of the mentioned tools need to function. It needs to be forged at an orange/yellow heat, but not as hot as the mild and medium carbon steels. It is very hard to fire weld with this material but it can be welded to low carbon steels with practice.

Practical approach to working

Always work out, either mentally or on a piece of paper, the steps involved to make the item to be made. Never start and hope that it will come out right because this is rarely a successful practice. Time spent thinking out the way in which each part of the forging is going to be manipulated will pay handsomely in the long run. It is a question of 95% what to do and 5% doing it. Once a plan is clearly formed, cut off the correct weight of material and start heating. Remember it is nearly impossible to increase the section by normal anvil work so start with the largest section material needed to reach the finished size required. Be sparing with the use of your hammer: wasted blows only tire you and create bad marks in the workpiece. Never consider a job unworthy of making special tools to fulfil a particular part of the job.

Many items made may be individual creations but repeats are sometimes required and it is good to keep a record of each significant job in note form in a pocket book. Keep a record of any drawings you have made and it may be as well to start a formal recording system.

Always finish off the work you start by filing the rough edges and leaving the piece in a state with which you are proud.

Calculations

Sometimes a smith is faced with finding out mathematical answers to questions, for instance, how much material will be required to produce a bolt so long? If a sample exists in a similar material, it is possible to weigh the sample and this gives the weight of the minimum material required to forge a replacement. It is wise to add some more material to the minimum so as to allow for wastage and for holding the workpiece, which may be an awkward shape otherwise. Volumes are being dealt with by the smith all his working life and this means measuring the length, the breadth and the height of a job so as to find a figure, which then needs multiplying by a coefficient factor to obtain a practice weight. Over a short period a

smith would then become very proficient in calculating weights and he, or she, should take the opportunity of keeping a notebook of items for future reference.

References and resources

Low Cost Forge Design, Stokes JB, Practical Action
Basic Blacksmithing, Harries D, et al, Practical Action Publishing, 1993
The Blacksmithing Instructors' Guide, Harries D, Practical Action Publishing, 1993
The Blacksmith and the Farmer, Poston D, Practical Action Publishing, 1994
Edge of the Anvil, A Resource Book for The Blacksmith, Andrews J, Practical Action Publishing, 1991
Blacksmith, Baker, Roofing Sheet Maker, Carr M, Practical Action Publishing, 1984
Blacksmith's Power Hammer for Local Manufacture, Lawrence S, et al, ITDG
Blacksmithing, Welding and Soldering, Van Winden J, TOOL, Amsterdam, 1989
Jobs from Junks, How to Create Employment and Tidy up Derelict Cars, Vogler J, Practical Action Publishing, 1983

This Technical Brief updated in September 2007 is based on *Forging Profile* produced for the Intermediate Technology Development Group ITDG (now known as Practical Action) by J. W. H. Silvester

technical brief