



Pigeons ¹

William H. Kern, Jr.²

The pigeons or rock doves (*Columba livia*) found in North America are the feral offspring of pigeons brought to this continent by European immigrants. Pigeons are domesticated animals raised for sport racing, show and for food (squab). The ancestors of the pigeons we see in our cities and on our farms escaped from captivity and found a favorable environment living with humans. Feral pigeons now have a cosmopolitan distribution, having become established every place humans have built cities.

Description

The feral pigeons found in Florida and North America are extremely variable in coloration. They exhibit the full range of coloration that domestication and selective breeding have produced. All pigeons that were developed from rock doves (Figure 1) have a white rump, usually a white diamond-shaped patch just above the tail feathers. In white birds the white rump blends with the general body color. Many pigeons have retained the ancestral rock dove coloration: gray body, darker gray head and neck, white rump, dark band on the end of the tail, dark

wing tips, and two black stripes running along the back edge of each wing. The total length is around 11-13 inches (28-33 cm).

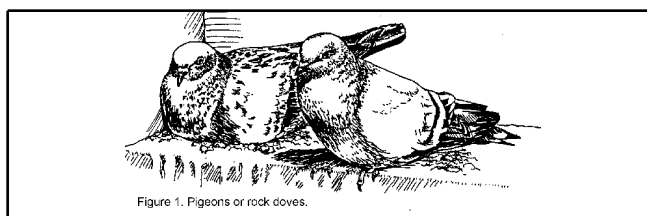

Figure 1.

Range and Habitat

The pigeon is found throughout Florida, congregating in urban, suburban, and rural agricultural areas. It is hard to know the range of the ancestral rock dove because feral pigeons are so widely distributed, but they are believed to naturally occur in southern Europe, the middle east and north Africa. Rock doves nest on protected cliffs and inside the mouths of caves. Human cities are made of artificial cliffs (buildings) and caves (attics, abandoned buildings, open warehouses) so these pigeons feel at home and flourish.

1. This document is Fact Sheet SS-WEC-117, one of a series of the Department of Wildlife Ecology & Conservation, Florida Cooperative Extension Service, Institute of Food and Agricultural Sciences, University of Florida. Originally published in cooperation with the Florida Fish and Wildlife Conservation Commission's Nongame Wildlife Program. Publication date: October, 1996. Minor Revisions: July, 2001. Please visit the Edis Web site at <http://edis.ifas.ufl.edu>

2. William H. Kern, Jr., Ph. D., former urban wildlife specialist, Department of Wildlife Ecology and Conservation, Pinellas County, Largo, FL, Cooperative Extension Service, Institute of Food and Agricultural Sciences, University of Florida, Gainesville, 32611.

<Disclaimer>All chemicals should be used in accordance with directions on the manufacturer's label. Use pesticides safely. Read and follow directions on the manufacturer's label.. The use of trade names in this publication is solely for the purpose of providing specific information. It is not a guarantee or warranty of the products named, and does not signify that they are approved to the exclusion of others of suitable composition.</Disclaimer>

The Institute of Food and Agricultural Sciences is an equal opportunity/affirmative action employer authorized to provide research, educational information and other services only to individuals and institutions that function without regard to race, color, sex, age, handicap, or national origin. For information on obtaining other extension publications, contact your county Cooperative Extension Service office. Florida Cooperative Extension Service/Institute of Food and Agricultural Sciences/University of Florida/Christine Taylor Waddill, Dean.

Food and Food Sources

Pigeons feed primarily on seeds and grain, but in urban areas they also eat human food scraps like bread crumbs, etc. Bird feeders provide a primary food source for pigeons in urban and suburban areas. Pigeons are especially fond of cracked corn and sorghum or milo seeds in general bird seed mixes. In agricultural areas pigeons eat or contaminate large amounts of livestock feed. Pigeons are not picky about their food: they are often seen picking undigested seeds from the feces of livestock.

Reproduction

Pigeons breed year round in Florida. The nests are simple platforms of sticks built in sheltered locations on horizontal ledges. Pigeons commonly nest on man-made structures; window ledges, balconies, under bridges, in barns and open warehouses, on or behind signs, and in soffits and attics of houses. They enter attics through missing soffit panels or attic vents. A clutch normally consists of 1 or 2 eggs. The incubation period is 16-18 days and fledglings leave the nest at 4-6 weeks of age. Adult pigeons feed their babies a material secreted by their crops called "Pigeon's milk".

Problems and Solutions

Aesthetic and Economic Problems

Pigeon droppings deface many urban buildings, monuments, and public spaces. The uric acid (white material) in their droppings is not just unsightly; it can damage the finish on buildings, automobiles, etc.. When birds occupy warehouses and defecate on stored goods, this creates an expensive problem for the warehouse management when their customers (retailers) refuse to accept contaminated goods.

Health-Related Problems

The most common problem associated with feral pigeons nesting in buildings is bird mites invading the human occupied space during or after the nesting season. Bird mites, like northern fowl mite and tropical fowl mite, will bite humans and cause a small pustule, similar to a chigger bite. Pigeons are also important reservoirs and vectors of reintroduction of fowl mites into previously treated poultry houses.

Pigeon nests can also be a source of stick-tight fleas, soft ticks, bed bugs, and dermestid (carpet) beetles invading buildings.

Pigeons have been long associated with disease organisms transmissible to humans and livestock. These include: 13 bacterial diseases including *salmonellosis* (*Salmonella* food poisoning), fowl typhoid, paratyphoid, *pasteurellosis*, *streptococcosis*, and *tuberculosis*; five fungal diseases including *aspergillosis*, *blastomycosis* and *histoplasmosis*; six protozoan diseases including *toxoplasmosis* and *coccidiosis*; *chlamydiosis*; the rickettsial disease Q Fever; eight viral diseases including eastern equine and St. Louis encephalitis, Newcastle disease and fowl pox of poultry; the tapeworms in the genus *Taenia*, *Davainea proglottina*, and *Railletina tetragona*; four genera of parasitic nematodes of poultry including *Tetramares* (2 sp.), *Capillaria* (5 sp.), and *Acuaria spiralis*; and 14 parasitic flukes of poultry, livestock, and humans.

Pigeons are generally a more serious disease vector to livestock, especially poultry and egg producers, than to humans. Still, the presence of pigeons where food is prepared or people eat—such as picnic areas and outdoor restaurants—should be a cause for concern about the spread of *Salmonella* bacteria.

Control

Exclusion

Exclusion is always the best option to a nuisance wildlife situation. Exclusion will also prevent most situations from developing. Make sure all attic and soffit vents are properly screened to keep birds and other animals out.

Large openings filled with heavy door curtains of plastic strip discourage entry; once inside, pigeons can be discouraged from roosting on ledges and light fixtures by installing sloping surfaces over the flat surface. This can be as simple as a board or sheet metal installed to create a 45° or greater slope (Figure 2a).

Birds nesting inside or behind signs can be excluded by sealing the edges of the sign with

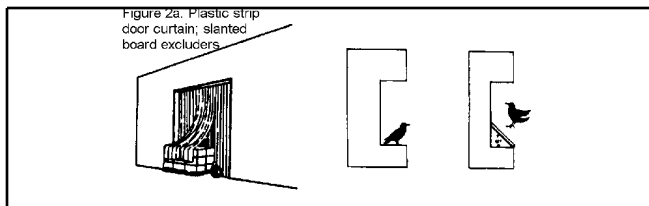

Figure 2.

hardware cloth and silicon caulk or with plastic bird netting.

In large open structures, like barns and warehouses, close off the space above the rafters where pigeons roost and nest with industrial bird netting (Figure 2b).

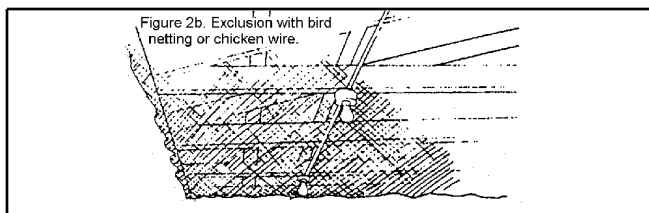

Figure 3.

Pigeons can be deterred from roosting on railings or pipes by suspending a wire or monofilament line 1 1/2 -2 inches over the center of the roost surface so that the birds will be off balance.

Tactile repellents used for pigeon management may be mechanical like porcupine wire (Figure 2c), wire loops, electrified wires on roosting surfaces, or sticky substances, usually containing polybutene. All the methods listed make surfaces uncomfortable or impossible for birds to roost on.

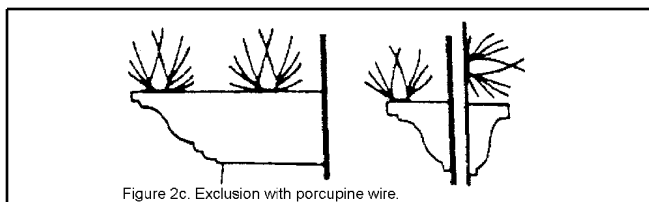

Figure 4.

Livestock area options

Livestock producers can also reduce pigeon problems. Clean up spilled grain and do not feed livestock on the ground. Store grain and feed in bird and rodent-proof storage bins. Use bird-proof livestock feeders, especially for swine. Feed livestock in covered areas like pole barns as these areas limit access (by) and are less attractive to

pigeons. Use feeds that are difficult for pigeons to handle such as blocks or cubes greater than 1/2 inch (1.5 cm) in diameter, silage or granular meal. Avoid using grain-sized pellets of approximately 3/16 inch (0.5 cm) in diameter. Mix protein supplements with silage or other feeds to reduce the pigeons' access to them. Adjust feeding times to when pigeons are less active if possible. Later in the afternoon is better than morning or midday. Feed cattle supplements at night. In those places where water is limited, pigeons can be discouraged by regulating watering troughs so the water is too low to be reached from the top edge and too deep to wade in.

Trapping

Use trapping, described in Figures 3 through 6, if a local pigeon population becomes a nuisance. Loft traps are used where large numbers of pigeons must be removed. These traps are usually made onsite since their large size prevents easy relocation.

The decision to construct and use a loft trap or smaller traps should be based on the economics of the situation. Are the pigeons causing enough economic loss to justify the cost of trap construction or purchase? Commercially produced pigeon traps are available with both bob-type and funnel-type entrances (Figure 3).

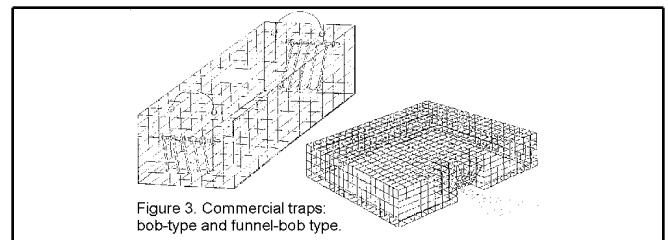

Figure 5.

In some situations numerous birds can be trapped at one time with a walk-in bob type trap (Figure 4) or low-profile bob-type traps (Figure 5) or by various funnel traps (Figure 6). The secret to trapping pigeons is pre-baiting about one week before setting the trap. Usually trap success will be good on the first day of trapping, fair on the second day, and poor by the third day. After the third day, it is time to pre-bait for another week. **Immediately release ANY non-target birds you trap and check your**

traps at least once every 24 hours. Supply water in your trap to avoid stressing captured birds and to act as an added enticement to enter the trap..

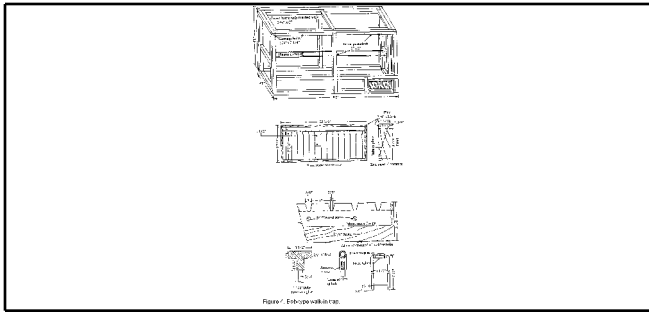

Figure 6.

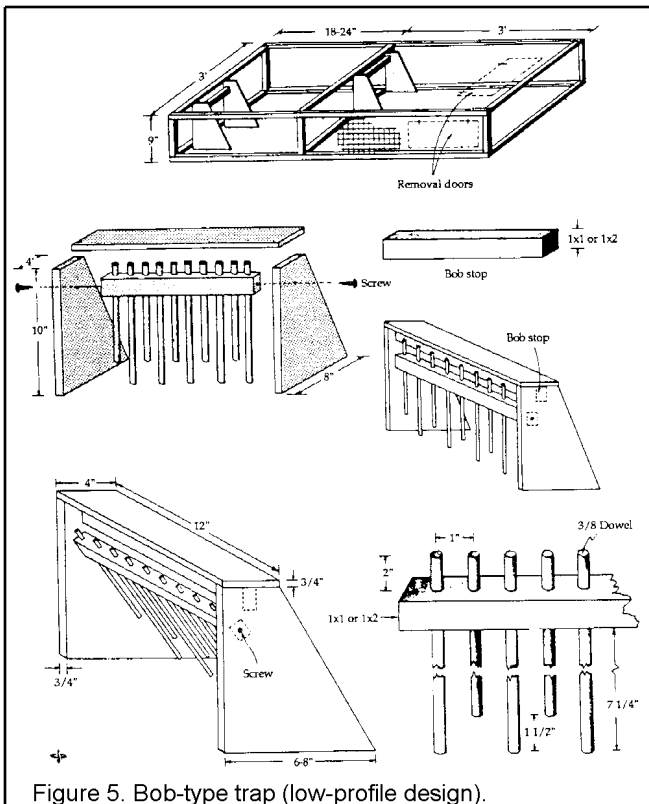

Figure 5. Bob-type trap (low-profile design).

Figure 7.

Active removal of nests, eggs, and chicks whenever they are found also helps manage pigeon populations. Check for and remove nests every two weeks for best results. By removing nests more often than every 18 days, you will not have to deal with chicks.

Shooting

Shooting is usually not a time effective way to control a pest bird situation. Before considering shooting as a control method, contact your local law

enforcement agency to find out about the laws in your area. (Some municipalities even designate pellet rifles and BB guns as firearms.) Many cities and towns also have local ordinances protecting birds-which may include pest species like starlings, house sparrows, and pigeons.

If you are legally permitted to use a weapon and local ordinances do not protect pigeons, it is wise to receive a type of firearm safety training. The Florida Game & Fresh Water Fish Commission offers free Hunter Education Classes that stress firearm safety as well as teaching hunting skills. Here you will learn it is safer to use a pellet rifle, shotgun or shot cartridges rather than solid bullets. (The bullet from a .22 long rifle can travel over 1.5 miles (2.4 km)). Any time you shoot, be absolutely sure where you are shooting and identify your back stop. A .22 bullet is capable of passing through corrugated tin, drywall, or plywood to hit anyone or anything behind it.

Another consideration is that racing pigeons often mix with feral pigeons. So, avoid shooting banded birds. *Note: this is easier said than done. Often the bands are only seen when the bird is in the hand.*

Poisons

Currently in Florida, the only registered avicide (poison for birds) is Avitrol™. It may only be used for pigeon control with an Avitrol permit issued by the Florida Fish and Wildlife Conservation Commission.

In order to get an Avitrol™ permit, you must adequately describe in your application how you will protect non-target birds from accidental poisoning. Pre-bait your baiting station for about a week with the same grain as the grain in your treated Avitrol™ bait. This will get the pigeons use to coming and feeding at your bait station. Use a sheet of plywood with a raised border as your baiting station. This will make it easier to collect all of the uneaten treated bait. Uneaten bait must be removed from the field at the end of the day. **Do not leave the station unattended at anytime while poison bait is present.**

Be ready to scare away all non-target birds that come to the feeding station, even if it means scaring

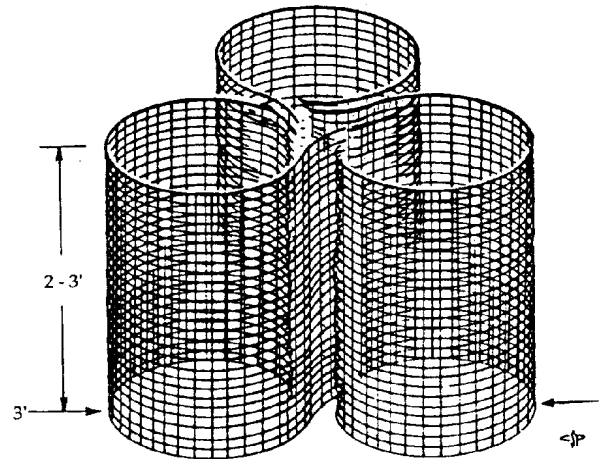
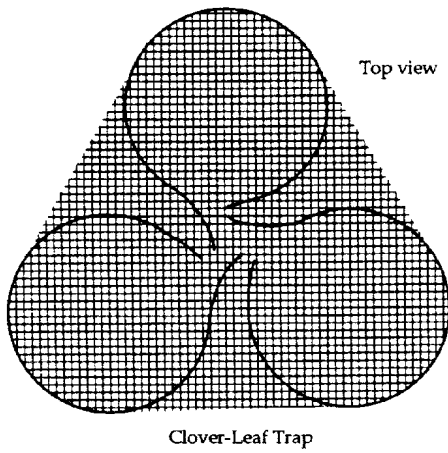
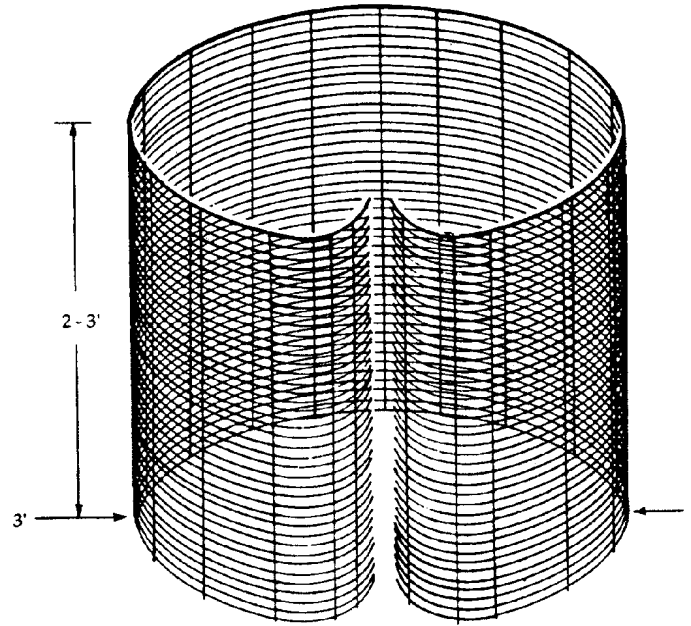
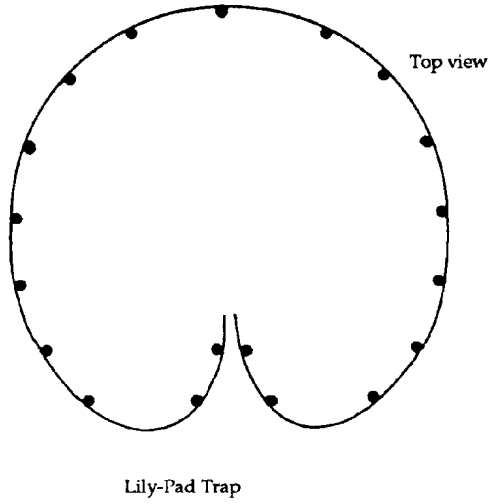
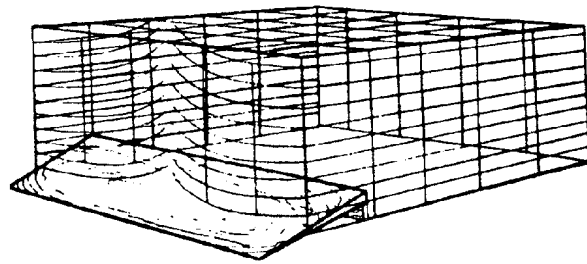

Figure 6. Lily pad funnel trap, clover leaf funnel trap, and double-funnel designs.



Double Funnel Trap

Figure 8.

away pigeons. Protecting non-target birds is your responsibility. When Avitrol or any other avicide is used, have crews patrolling the area to collect downed birds quickly.

Be aware that the use of poisons on birds will often cause negative publicity and therefore it is not recommended for public places like shopping centers, tourist attractions, and densely occupied urban areas. It is more appropriate for agricultural situations and large industrial complexes where access by the public is limited or restricted. When discretion is needed, discrete trapping is preferred over the use of poisons.

Repellents

Repellents such as naphthalene are registered for nuisance bird control, but they are rarely effective and are never a permanent solution. Naphthalene, in the concentrations needed to repel pigeons, is unpleasant to people and pets as well.

Sound Repellents and Startle Devices

Sound has been tried in many ways to scare away birds. Loud noises like those produced by firearms, pyrotechnics, or propane exploders may scare away flocks of pigeons from a particular area for a short time.

Loud noises are useful for protecting newly planted fields, but have limited usefulness in urban areas and around livestock. Unless the noises are randomly discharged, the birds quickly learn to ignore the sound. Also, producing loud noises during all daylight hours will quickly irritate all but the most understanding of neighbors and may violate noise ordinances.

Ultrasonics. People have tried to get around this problem by using ultrasonic devices that produce sounds above the threshold of human hearing. Ultrasonic devices have problems. Ultrasonic waves reflect off objects, they don't go around them. This produces sound "shadows" where the birds can avoid sound. Research at Purdue University has also shown that some of these devices cause hearing loss in dogs and, probably, cats.

In general, ultrasonic devices rarely drive pest birds from established home ranges. *Note: Pigeons*

have also been observed nesting on top of a functioning ultrasonic repeller, so their effectiveness is questionable.

Distress calls. Another use of sound tried with other species involves recorded distress calls of the target bird species. However, pigeons don't appear to have a distress call- it is the loud flapping sound of a startled bird usually alerts the rest of the flock to danger.

Effigies ("scarecrows") have been used to control bird damage in the past. Models of owls, hawks, snakes, and cats have all been used. To keep these "scarecrows" effective they must appear life-like and must be moved often so the birds do not become accustomed to seeing them in the same spot every day. Balloons with eye-spots, kites with hawk silhouettes, and streamers are more effective because they move.

Mylar™ streamers are effective near roost sites. The lightweight streamers easily blow around in the slightest wind and make birds very nervous, especially when the long streamers reach out toward or touch the roosting birds. Flashing lights and moving shadows have also been used. Roosting pigeons can be driven from roost sites by harassing the birds at dusk for three or four consecutive nights or until they find a different roost.

Spraying the birds with water from a hose or harassing them in other ways encourages the birds to move on. Start harassment as soon as the birds begin roosting. Don't wait until the roost is well established and the birds develop a strong attachment for the site. Be persistent until the problem is solved.

LEGAL ASPECTS

The feral pigeon is an exotic species in North American and is listed as an unprotected species by the U. S. Fish & Wildlife Service and as feral livestock by the Florida Fish and Wildlife Conservation Commission. The birds, their eggs and nests may be removed by any method except by poison, steel traps, or with guns and lights at night. Some municipalities have issued local ordinances that protect all birds, both exotic and native. Be sure to check with local authorities before starting any bird

control activities. If tagged birds are trapped or captured, contact the Pigeon Air-Racing Union to return these racing pigeons to their rightful owners.

SUGGESTED READINGS

Peterson, R.T. 1947. *A field guide to the birds: Eastern land and water birds*. Houghton Mifflin Co., Boston. 230 pp.

Robbins, C.S., B. Bruun, and H.S. Zim. 1966. *A guide to field identification of birds of North America*. Golden Press, New York City. 340 pp.