

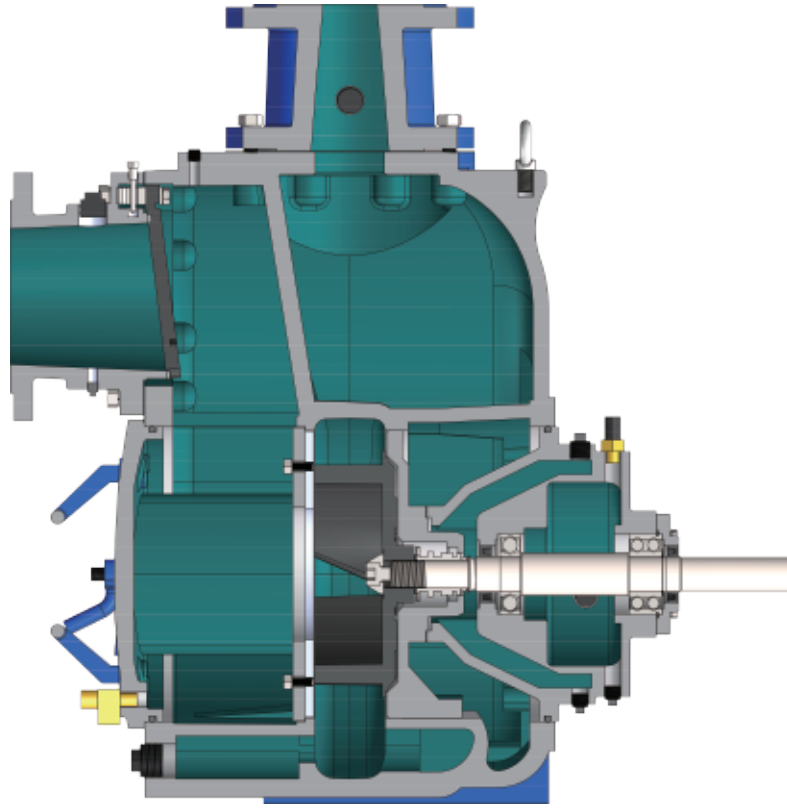

**AMOS**  
A MODEL OF SUCCESS IN FLUID TECHNOLOGY



# MCT SERIES SELF PRIMING TRASH PUMP



MCT

SECTIONAL VIEW

## PRODUCT FEATURES

MCT series pumps are designed for economical, trouble-free operation. The superior solids handling capabilities of the pump make it ideally suited for a variety of applications including solids-laden liquids and slurries. The impeller, seal, wears plate and flap valve can all be accessed through the cover plate opening for inspection or service. Atmospheric barrier along with a lip seal provide additional protection of bearings, also allows external monitoring. Cartridge mechanical seal is specifically designed for abrasive and or trash handling service. The entire rotating assembly can be removed without disturbing pump volute or piping .

## ▼ OUTLINE DIMENSIONS [ Unit: inch ]

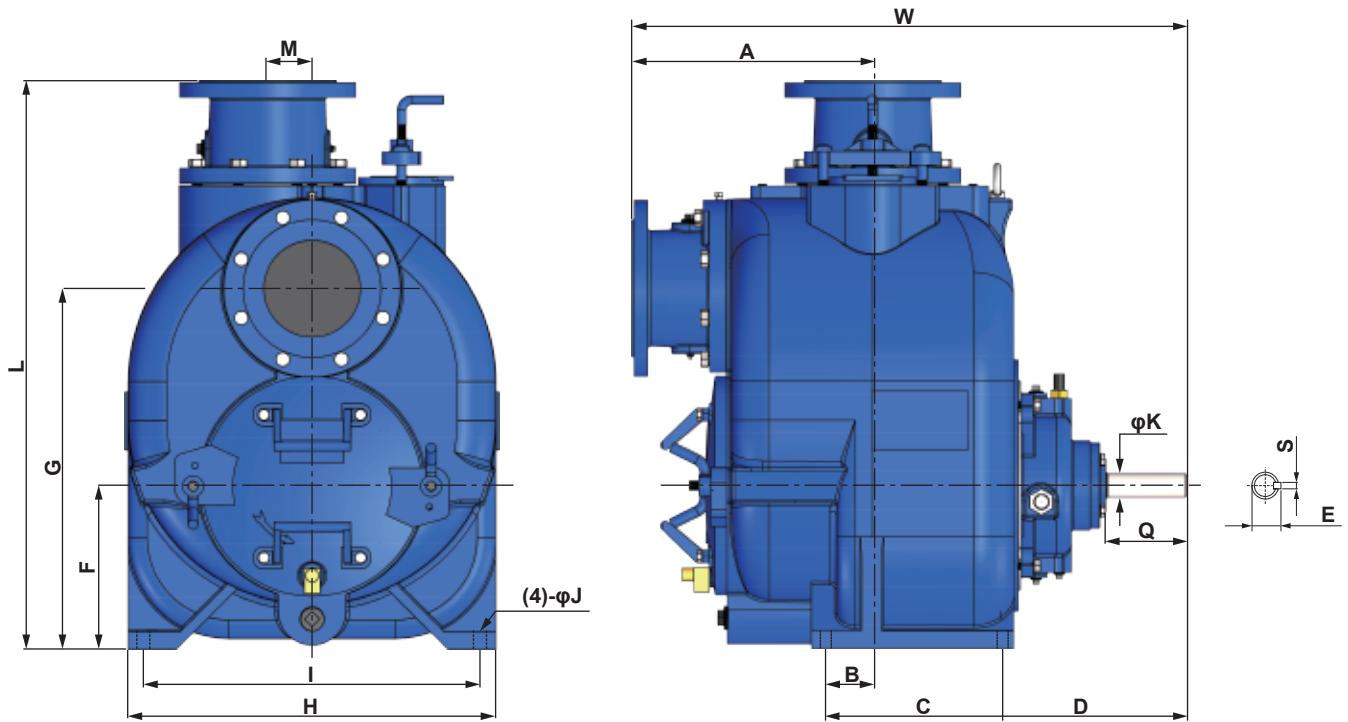

Pump Type	L	G	F	I	H	M	J	W	A	B	C	D	K	Q	S	E	Bare Pump Weight (kg)
MCT-2	20.73	12.52	5.97	11.00	12.13	2.75	0.55	24.45	9.52	2.13	6.44	10.63	1.50	4.00	0.375	1.68	131
MCT-3	27.04	17.00	7.50	15.50	17.00	2.75	0.71	28.88	11.54	3.00	9.00	11.34	1.50	4.00	0.375	1.68	248
MCT-4	29.22	19.50	8.75	18.00	19.88	2.75	0.71	32.03	12.47	3.00	11.00	11.57	1.50	5.00	0.375	1.68	322
MCT-6	35.3	22.38	10.13	20.75	22.83	2.75	0.71	35.42	15.86	3.06	11.00	11.62	1.50	5.00	0.375	1.68	473
MCT-8	42.04	28.50	13.00	25.00	27.76	-	0.87	40.50	16.20	4.00	12.00	16.31	1.75	6.61	0.375	1.93	633

## ▼ MCT-10 OUTLINE DIMENSIONS [ Unit: inch ]

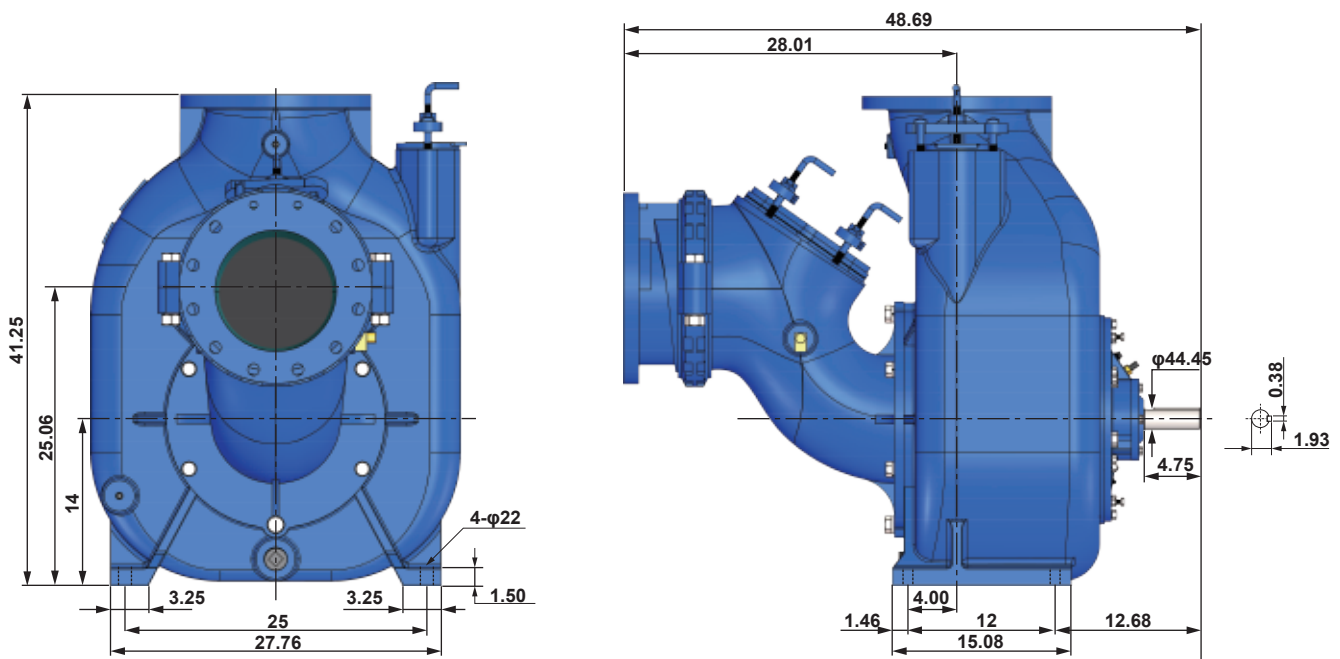

# PERFORMANCE CHARTS

MCT SERIES SELF PRIMING TRASH PUMP

