

Is it possible for small Municipalities to flow meter, identify and quantify Inflow/Infiltration, identify the location of the I/I without breaking the bank?

George Young, PE, MBA

Chesley Associates, Inc.

55th Annual OTCO Wastewater Workshop

Chesley Associates, Inc.

CAI CHESLEY ASSOCIATES, INC.



George Young

5583 Ridge Avenue

Cincinnati, Ohio 45213

513-531-7103

Fax 513-531-0445

Email: chesley.gyoung@gmail.com

www.chesleyassociates.com

Representing Leading Water and Wastewater Treatment
Equipment Manufacturers

Identifying Inflow/Infiltration Sources has been a difficult and expensive problem for Municipalities for decades with combined sewers and aging infrastructure allowing for excess flow to enter collection systems throughout the Midwest causing high flows at the WWTP, overflows, regulatory agency calls, and general headaches/heartaches whenever it storms.

WHAT IS I&I

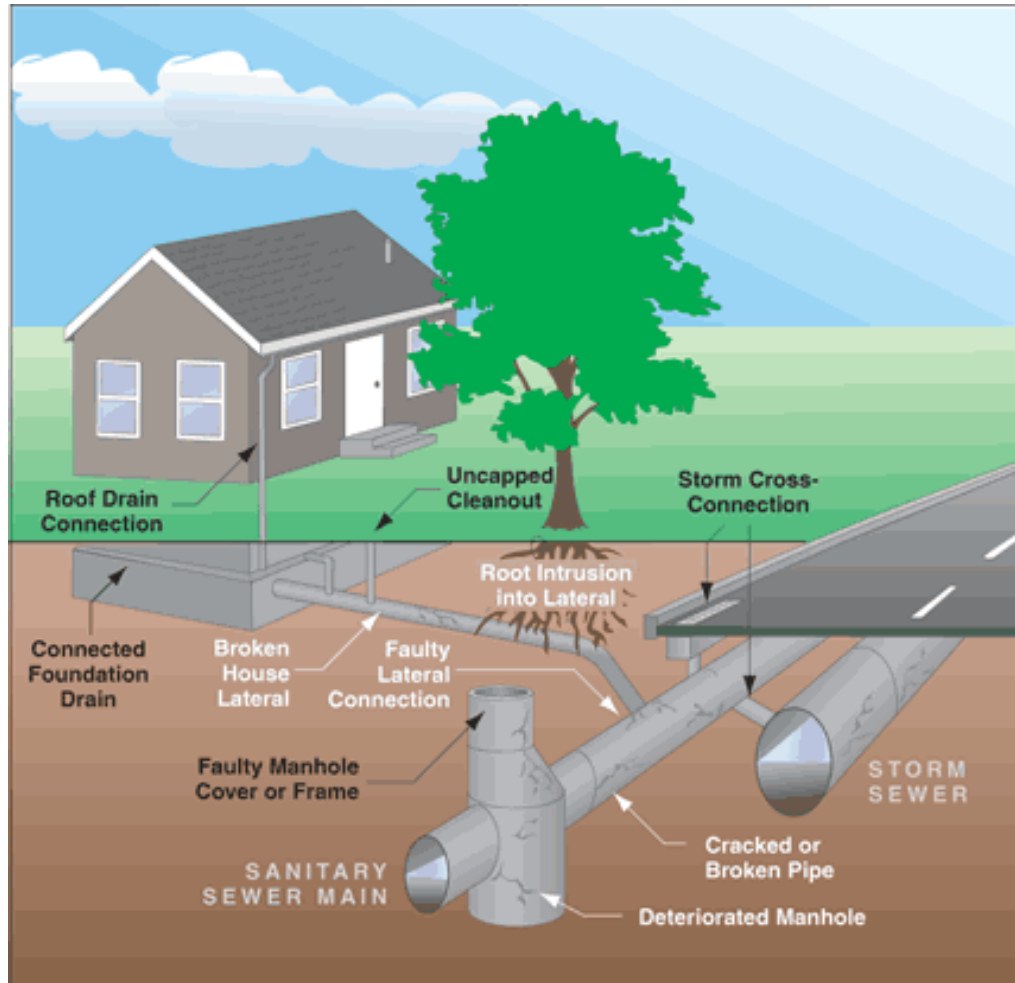

Key:

- ← Inflow Source
- ← Infiltration Source

- **Inflow:** Water flowing directly into the system

- **Infiltration:** Water indirectly leaking into the system

I&I can cause:

- Overflows
- Early expansion of a collection system or WWTP

Flow meters can be used to isolate sources of flow that the collection system is not intended to carry (I&I), such as rainwater and/or groundwater.

Inflow/Infiltration Source Detection

- Flow Metering
- Smoke Testing
- Dye Water Flooding
- Manhole Inspection
- CCTV

Flow Metering

- Why Flow Meter?
 - Measure Actual Flow
 - Organize Collection System into Sub Basins
 - Allows Delineation and Prioritization
 - Compare Post Rehab to Pre Rehab Numbers
 - Verify Plant Meter

Some initial questions that usually arise are

1. Where do I get started?
2. How do flow meters work?
3. Are they difficult to use?
4. What kind of manhole do I put a flow meter in?
5. Great, I installed the flow meter, now what?

Knowing how to get a program started is half of the battle. This presentation will assist the small municipality in identifying if a flow metering program is needed, general cost, and benefits from running an ongoing program.

The overall goal of this presentation is to help a Municipality make an informed decision about implementing a Flow Monitoring program to address their Collection System issues.

Flow Metering

- Base Flow
- System Characteristics
- Infiltration
- Rain Dependent Inflow
- Capacity
- Flow Balancing/Basin Development

Flow Metering

Base Flow

- Base Flow is dry weather flow that displays the normal running state at metering points in a collection system.

Flow Metering

Base Flow

Located at the North End of Town in MH226 West of SR66.

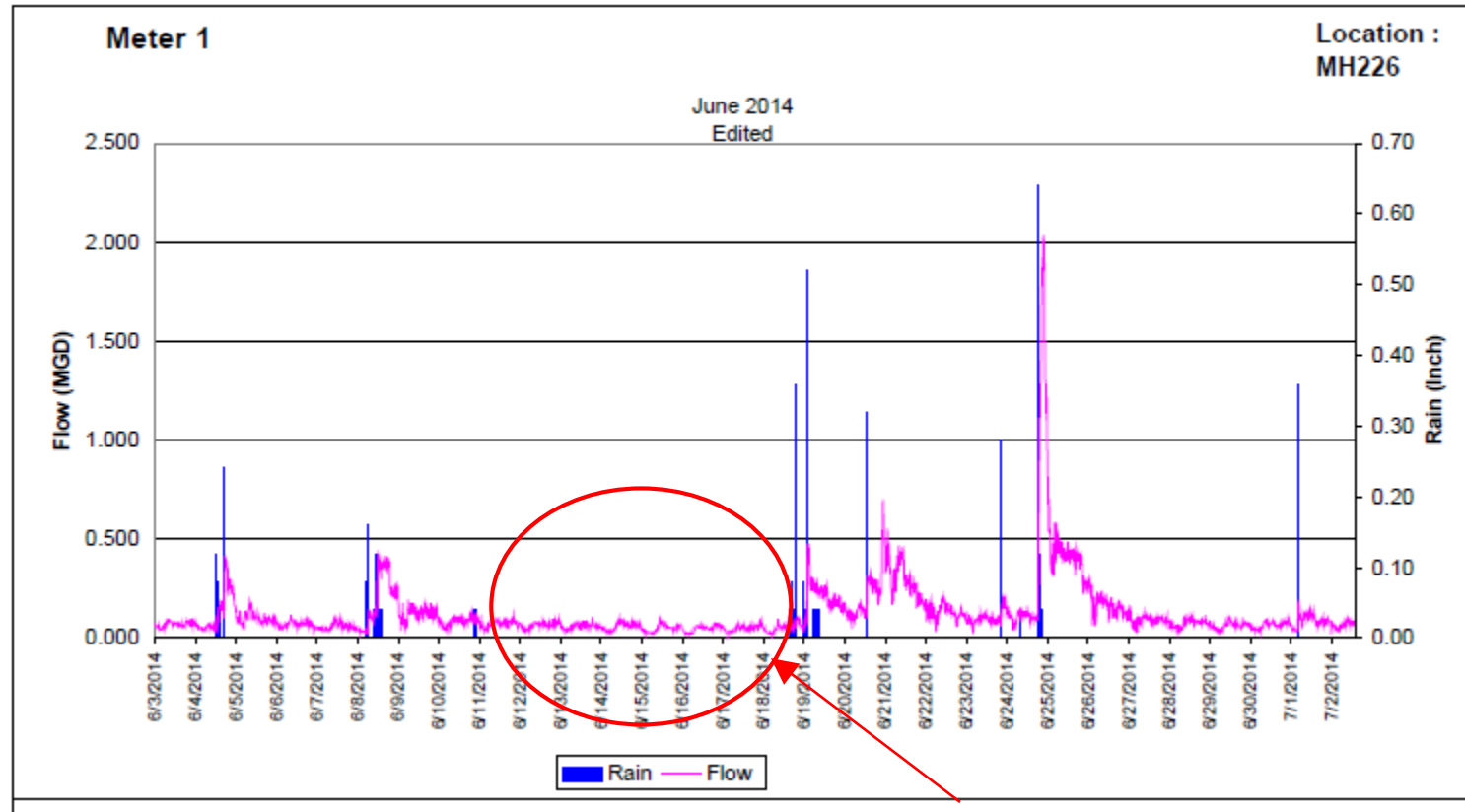

Base Flow

Flow Metering

Infiltration

- Infiltration is groundwater that enters the collection systems through cracks or faults in the system below the groundwater table. Infiltration is not directly tied to rainfall events.

Flow Metering

Infiltration

Located at the North End of Town in MH210 East of SR66.

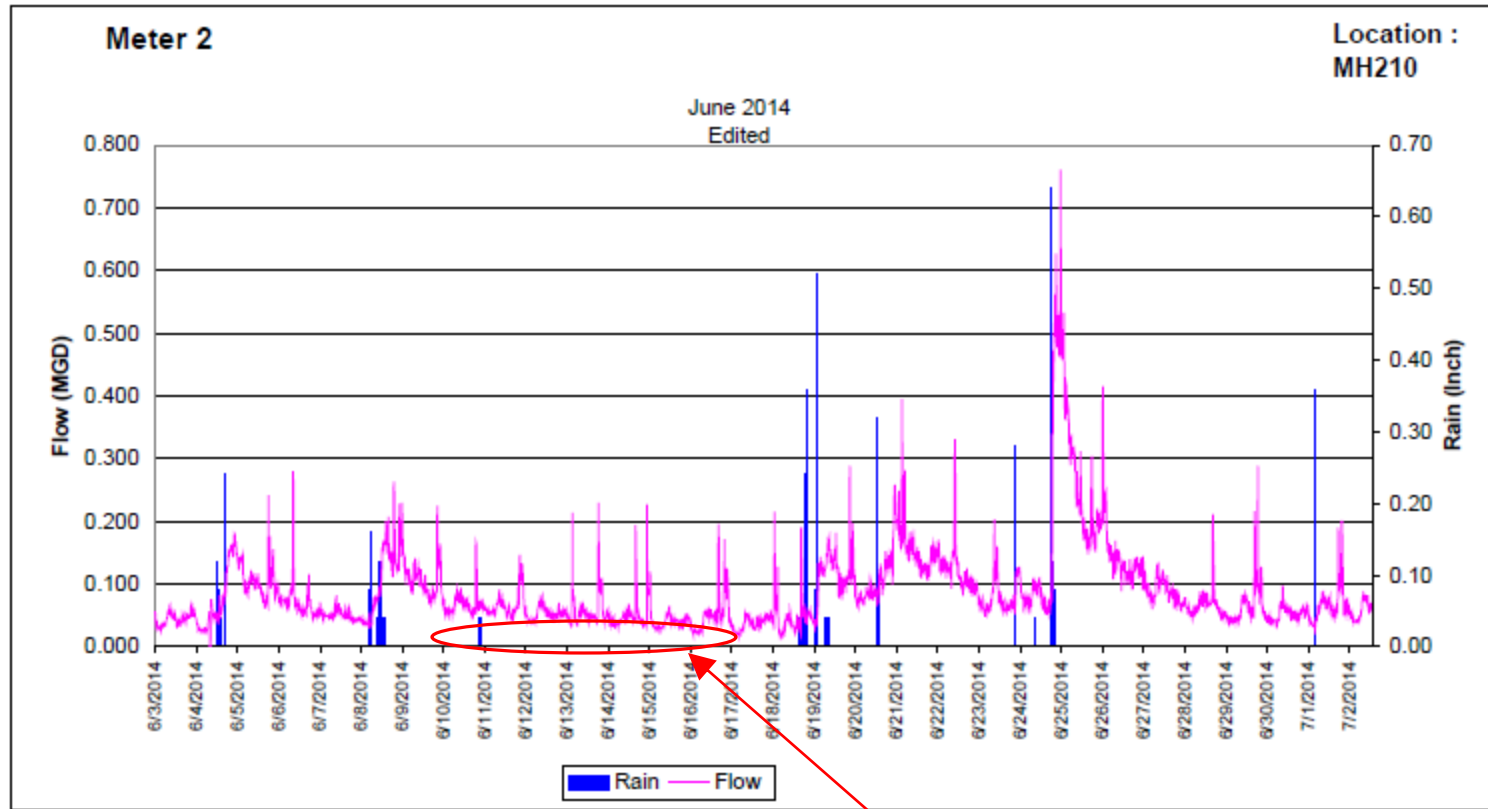

Infiltration

Flow Metering

Rain Dependent Inflow

- Rain Dependent Inflow is the water that enters the collection system directly during rainfall events through connected assets such as manhole covers, roof leaders, storm catch basins, and area drains.

Flow Metering

Rain Dependent Inflow

Located at the North End of Town in MH210 East of SR66.

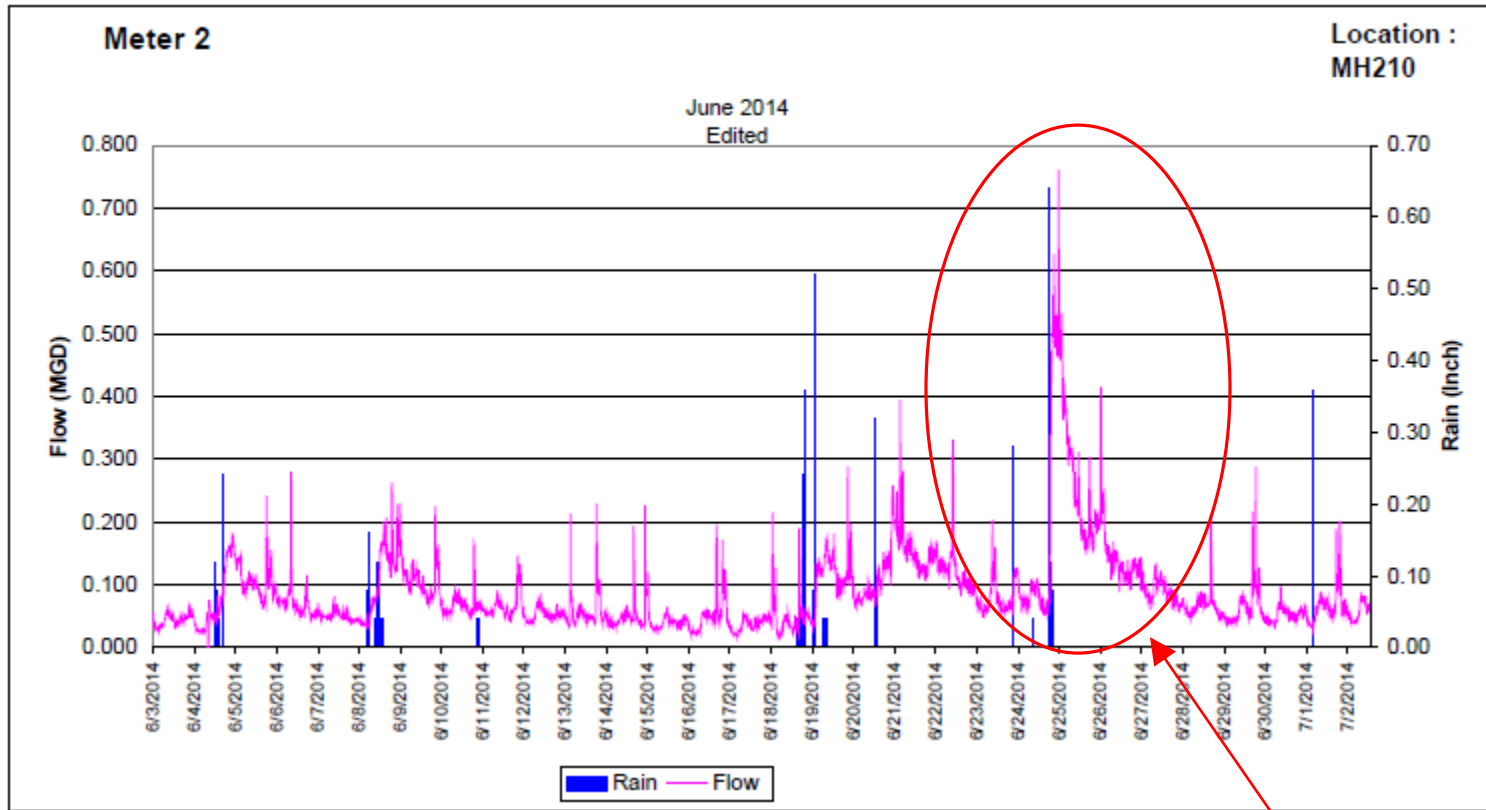

Inflow

Flow Metering

Capacity

- Capacity is defined for flow metering purposes as the amount of level in the pipe compared to the pipe size at the metering location(s). For analysis purposes, base flow capacity and wet weather capacity is monitored during the study and noted if concerns arise.

Flow Metering

Capacity

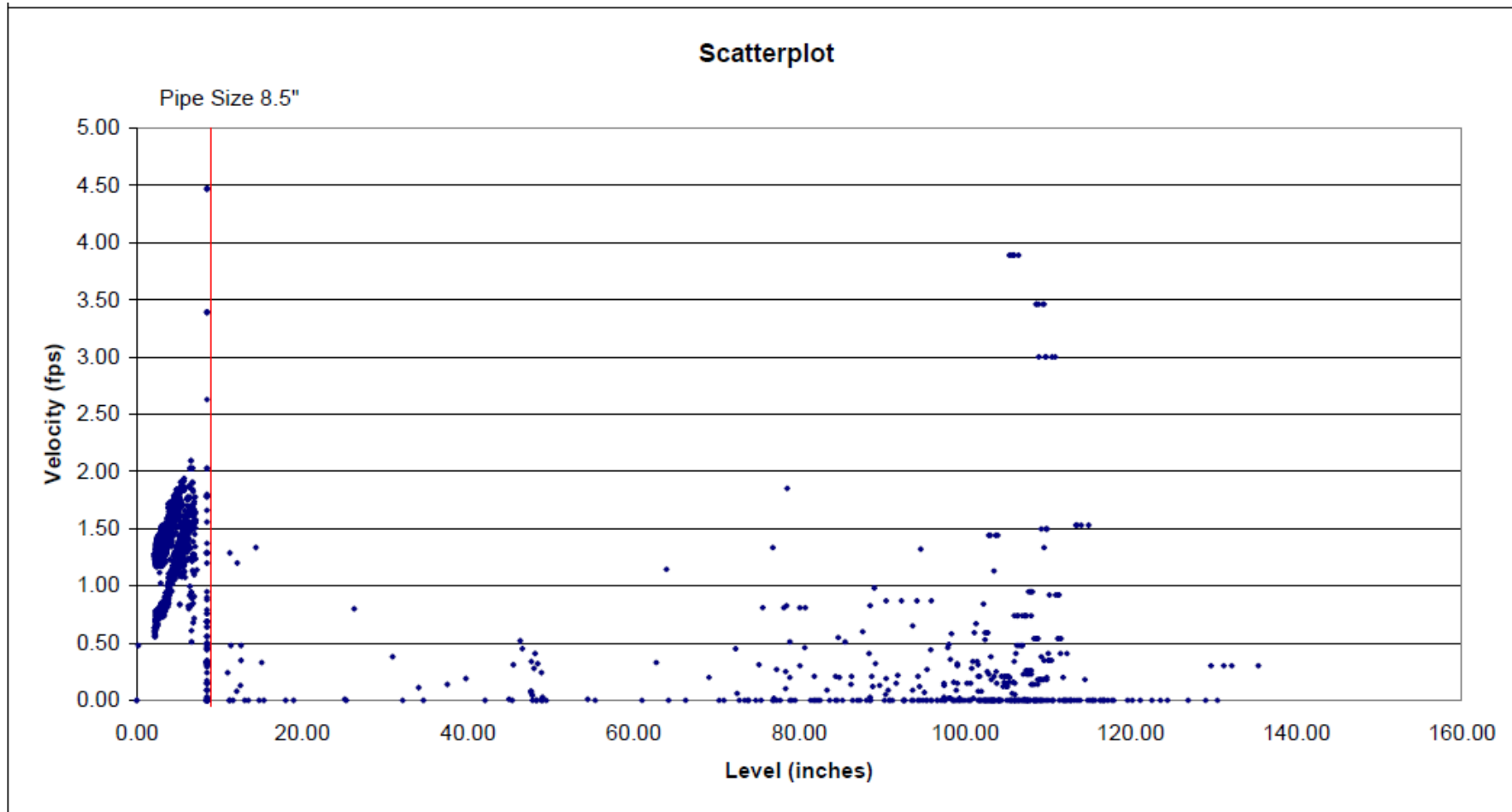

Flow Metering Balancing/Basin Development

- An important part of Flow Metering is dividing the collection system into sub basins to isolate areas with high Inflow and Infiltration.

Flow Metering

Balancing/Basin Development

Metering Schematic
June 2014

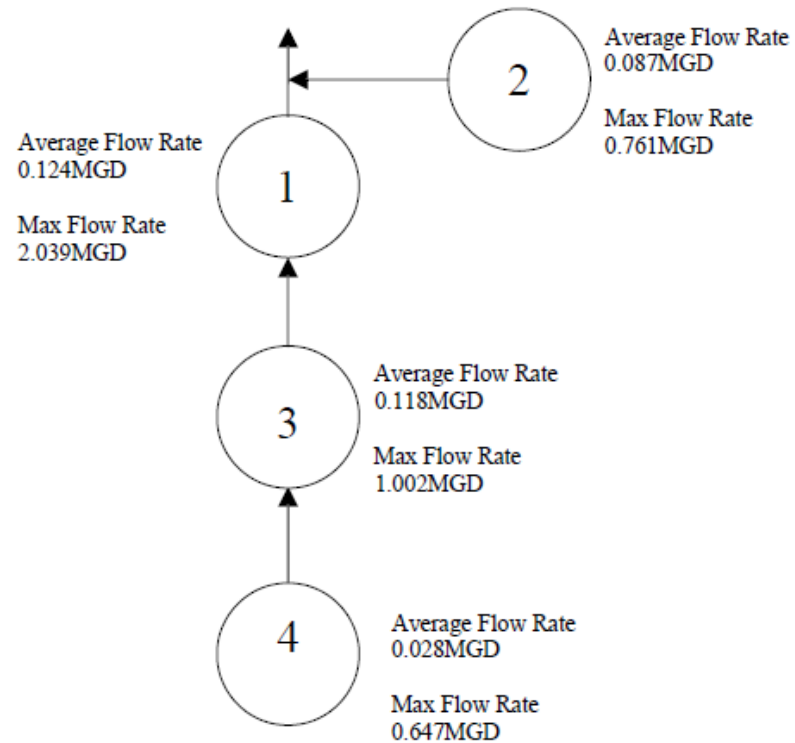

Flow Metering Equipment

- Flow Logger – powers the system, holds the data until retrieval

**Hach FL900
Standard (Non-Wireless)
Flow Logger**



When combined with the Flo-Dar[®], Flo-Tote[®] 3, AV9000 module and IM9001 module, the Hach FL900 Series Flow Logger takes flow monitoring to a whole new level. With features that reduce site time and increase crew safety, the flow monitoring system allows you to easily manage your flow data, as well as your budget.



Flow Metering Equipment

- Sensors – attached to the flow logger to read the characteristics of the flow... Level and Velocity which converts to Flow.

FLO-DAR® AV SENSOR



Applications

- Wastewater
- Collection Systems
- Industrial Water

The FLO-DAR® AV Sensor provides an ideal solution for non-contact, maintenance-free portable or permanent sewer flow monitoring.

SIGMA AREA VELOCITY FLOW SENSORS

Provides reliable, accurate data with minimal maintenance and greater life expectancy.



The Hach Sigma AV Flow Sensor is a robust sensor specially developed to withstand harsh environments typical of collection systems. It provides reliable, accurate data with minimal maintenance and greater life expectancy.

Flow Metering

Submerged Sensor Setup

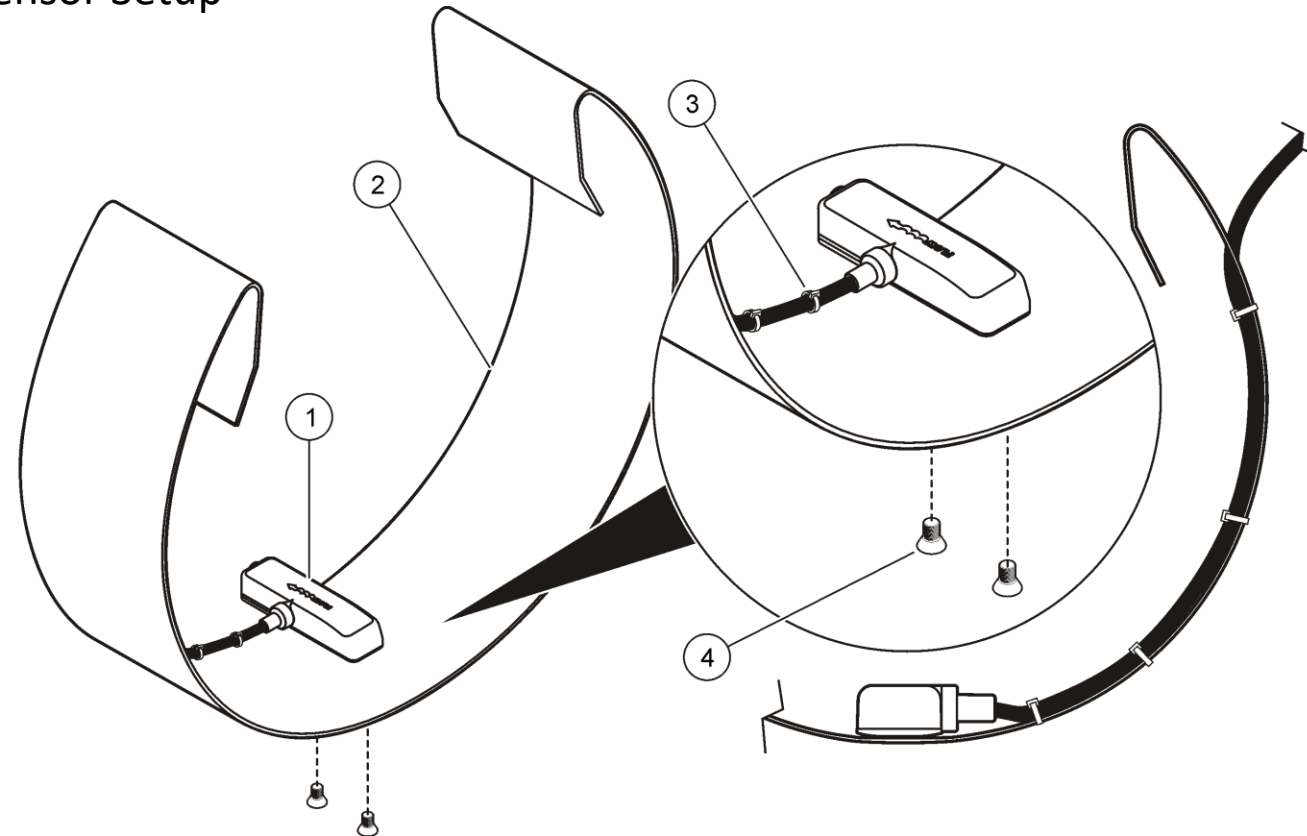

Flow Metering

Offset Mount Due to Debris

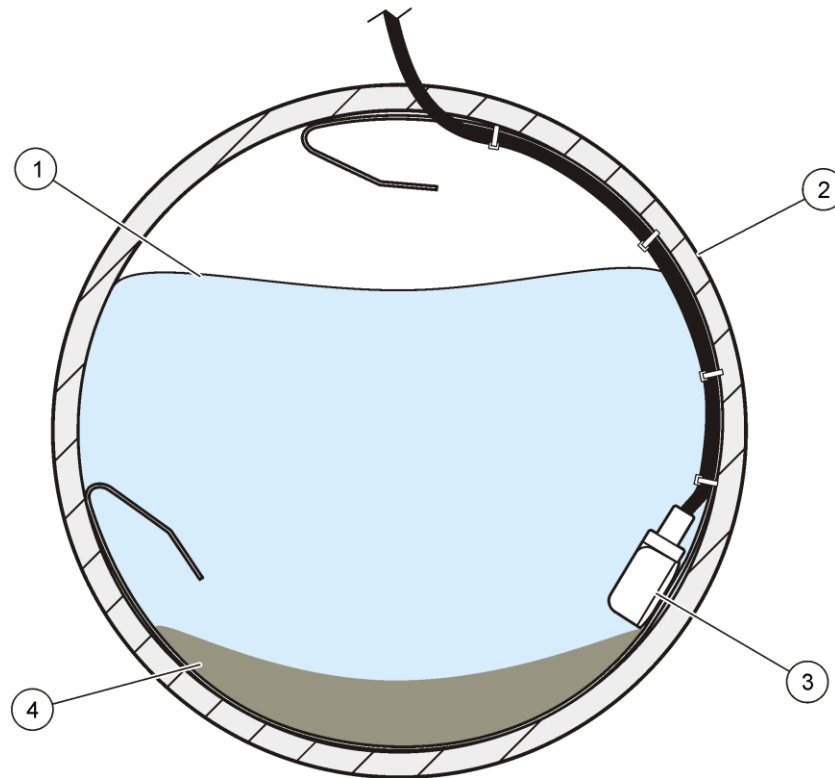

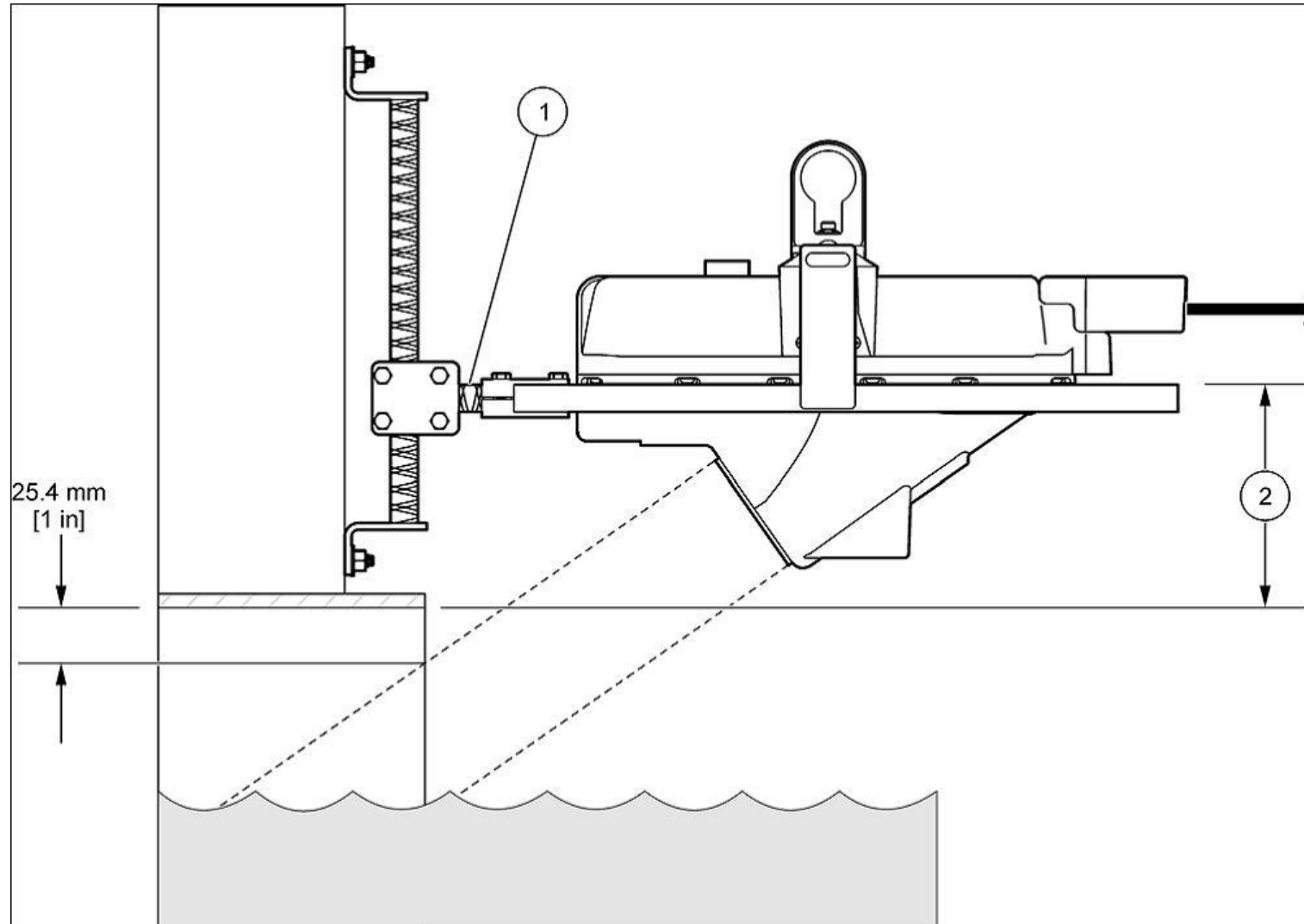

Installation Pictures



Chesley Associates, Inc.



Woo Hoo! The Meters are Installed!

now what?

Chesley Associates, Inc.

Located at the North End of Town in MH210 East of SR66.

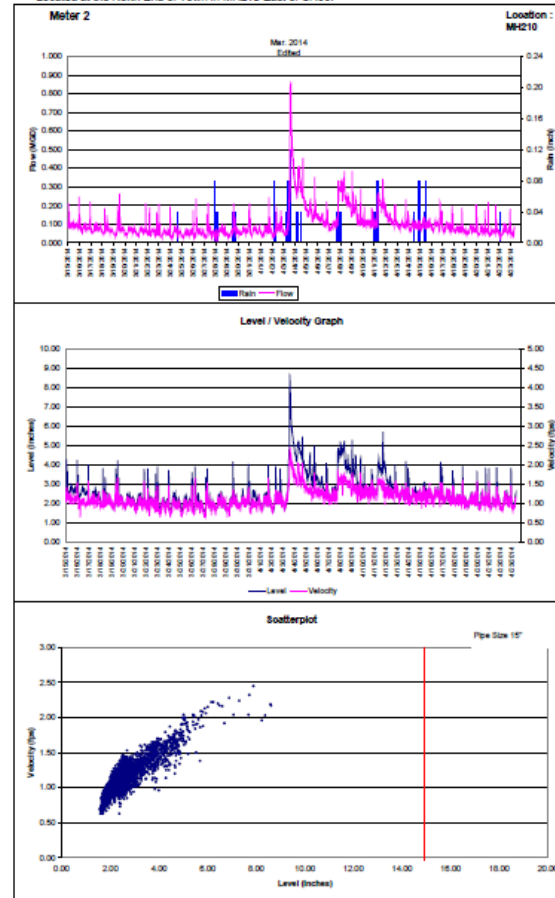

Chesley Associates, Inc.

Average Level (Inches)	2.56		
Minimum Level (Inches)	1.50		
Maximum Level (Inches)	8.62	Maximum Flow Rate (MGD)	0.866
Average Velocity (ft/sec)	1.13	Average Flow Rate (MGD)	0.099
Minimum Velocity (ft/sec)	0.63		
Maximum Velocity (ft/sec)	2.45		

Chesley Associates, Inc.

Date	Flow (MGD)
4/14/2015	0.142
4/15/2015	0.113
4/16/2015	0.096
4/17/2015	0.079
4/18/2015	0.072
4/19/2015	0.099
4/20/2015	0.138
4/21/2015	0.113
4/22/2015	0.119
4/23/2015	0.098
4/24/2015	0.081
4/25/2015	0.094
4/26/2015	0.078
4/27/2015	0.059
4/28/2015	0.047
4/29/2015	0.040
4/30/2015	0.040
5/1/2015	0.034
5/2/2015	0.036
5/3/2015	0.036
5/4/2015	0.063
5/5/2015	0.056
5/6/2015	0.042
5/7/2015	0.035
5/8/2015	0.031
5/9/2015	0.029
5/10/2015	0.028
5/11/2015	0.038
5/12/2015	0.025
5/13/2015	0.018

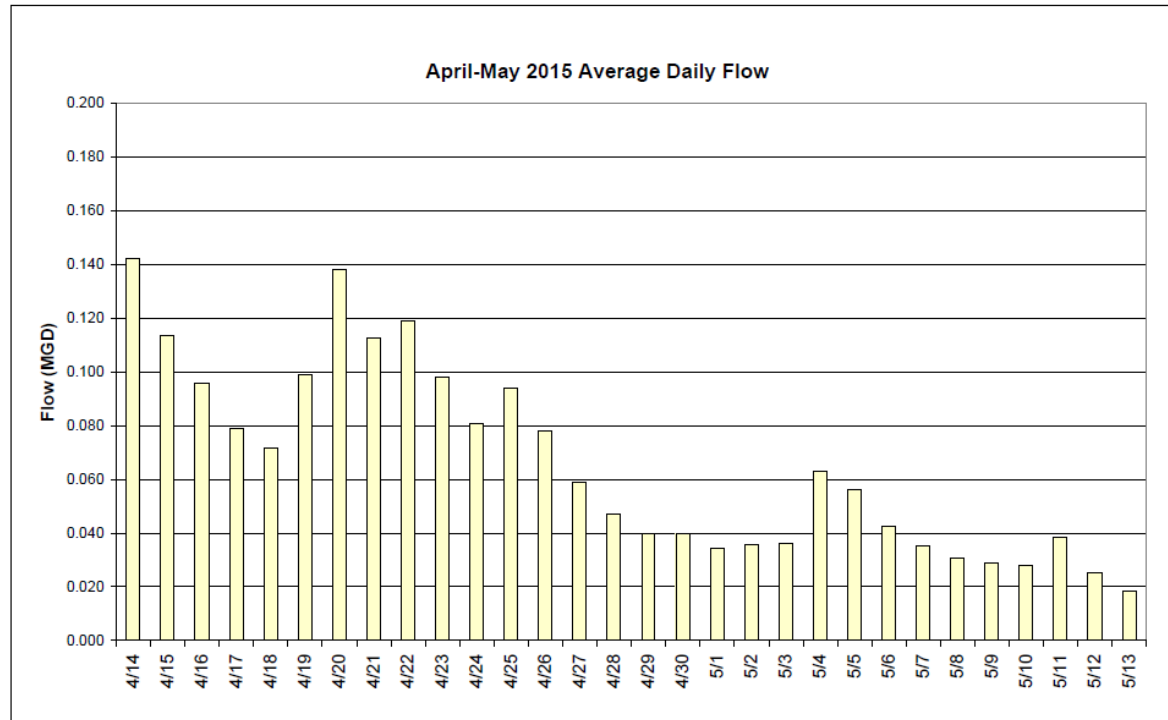

RAIN DEPENDENT INFLOW AND INFILTRATION METER NO. 4

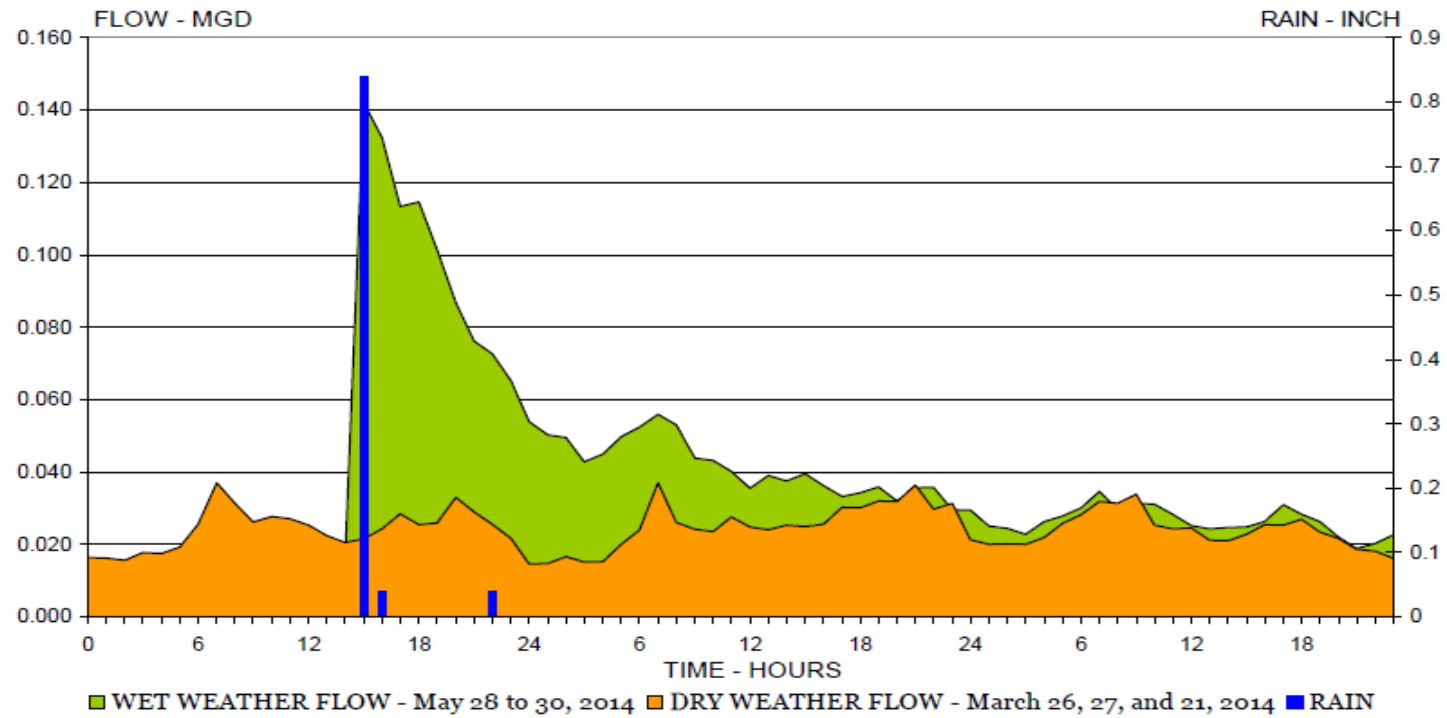

Chesley Associates, Inc.

The BIG QUESTION.... What is the COST?

For a 4 meter study for 3 months

Equipment

3 Submerged Meters with a variety of Mounting Bands (Purchase) \$15k

Install and Maintenance Performed by Municipality \$0k

Monthly Reporting and Final Report with Recommendations \$9k

(3 Months)

Incidental additional costs would include 6 volt battery \$1k

changes, extra site visits, etc...

Total Cost \$25k

Chesley Associates, Inc.

Questions?



Go Bucks!

