

# Hydrant Flushing for Water Quality Maintenance

Marvin Gnagy, P.E., President

 PMG Consulting, Inc.

OTCO Distribution Workshop

November 15, 2023

# Agenda

- Basics of hydrant flushing
- Distribution water quality issues
- Scouring vs. Flushing
- Determining hydrant flows
- Proper flushing areas
- Flushing and residual monitoring
- Recordkeeping
- Questions



# Hydrant Flushing Basics

- **Purposes**
  - Remove sediment and scale
  - Remove stagnant water
  - Increase disinfectant residuals
  - Verify hydrant operation
  - Verify hydrant flow rates
  - Remove air/sediment from repairs
  - Remove biofilms
  - Remove excess turbidity and discolored water
  - Routine annual or semi-annual flushing programs
  - Improve system water quality



# Hydrant Flushing Basics

## ■ Purposes

- Remove sediment and scale
- Remove stagnant water
- **Increase disinfectant residuals**
- Verify hydrant operation
- Verify hydrant flow rates
- Remove air/sediment from repairs
- Remove biofilms
- Remove excess turbidity and discolored water
- Routine annual or semi-annual flushing programs
- **Improve system water quality**



# Distribution Water Quality Issues

- Primary issue is disinfectant residual decline
  - Numerous causes
    - Half-life of disinfectant residual
    - Chemical equilibrium effects
    - Biofilms, scales
    - S/V ratios (piping impacts)
    - Elevated water temperatures
    - Nitrification
    - Presence of demand-causing substances (iron, manganese, nitrite, ammonia, etc.)
    - High water age and stagnant flow conditions



# Distribution Water Quality Issues

- Pipe materials and colored water
  - Red or brown discoloration water most common
    - Dissolution of iron
  - Yellow, dark brown, or black color
    - Presence of manganese and different oxidation states
- Turbidity
  - Usually from corrosion byproducts or scales
  - Often after hydrant flushing to remove scales and tuberculation
  - Sediment from stored water facilities
- Backflow occurrences



# Distribution Water Quality Issues

- **Microorganisms**
  - Improper disinfection or low disinfectant demand
    - Bacteria, amoeba, Legionella, etc.
    - Distribution regrowth
    - High HPC
  - New water mains
    - Poor sample technique
    - Improper disinfection
    - Pipe not cleaned during installation
  - Backflow occurrences





# Distribution Water Quality Issues

## ■ Tastes and odors

### ■ Chlorinous

- High residual levels
- Chlorinated organics

### ■ Metallic

- Iron, manganese, zinc

### ■ Medicinal

- Phenols

### ■ Earthy, musty

### ■ Flower-like

### ■ Fruity

### ■ Vegetable-like

Algal effects





# Scouring versus Flushing

- **Scouring to remove scale or tuberculation**
  - Relatively high flow velocities to loosen scale or corrosion byproducts
  - AWWA recommends water main velocities for scouring
    - **3.0 ft/sec** or greater (WRF 4307, AWWA C651-15)
    - Difficult to achieve in large mains
  - Higher scouring velocities
    - **5 ft/sec** preferred by some people for scouring operations
    - May be difficult to achieve in 14-inch or larger mains
  - Unidirectional flushing practices
    - Valve manipulation to reverse water flows or alter flow direction
    - Useful for highly scaled mains but not as common as you think



# Scouring versus Flushing

- Large mains may require more than one hydrant to reach scouring velocity in mains
  - Greater than 12-inch diameter
  - Mains larger than 14-inch diameter may be transmission mains and flushing is not routinely needed
    - Normal water flows adequate to prevent sediment build-up
  - High flows can produce damage to lawn areas, flood streets



# Scouring versus Flushing

- Regulatory agency may require dechlorination during flushing
  - Access to stormwater discharges
  - Access to waterways of the state
  - Other natural water habitats
- Bisulfites, metabisulfites, ascorbic acid most common dechlorinating agents
  - Maximum chlorine residual for discharge varies 0.1 mg/L to 0.19 mg/L (state-specific)



# Scouring versus Flushing

- **Water quality flushing at lower flows**
  - 150 gpm to 350 gpm does not produce main scouring
  - Lower flows remove stagnant water replacing with fresher water without scouring and creating turbid water
    - Increases disinfectant residuals
    - Temporarily reduces water age impacts
    - Temporarily reduces biofilm effects



# Scouring versus Flushing

- Successfully used in water systems to improve water quality
  - Particularly in summer months
  - Helps reduce nitrification events
  - Helps maintain disinfectant residuals above minimum levels
  - Helps remove stagnation and reduces biofilms





# Scouring versus Flushing

- Hydrant flows need to be monitored to prevent scouring for water quality maintenance
  - Different monitoring practices available
    - Meters
    - Pitot gauges
    - Estimated flows from equations



# Determining Hydrant Flows

- Several methods available
  - Flow meters
  - Pitot gauges
  - Calculated height and distance (physics)

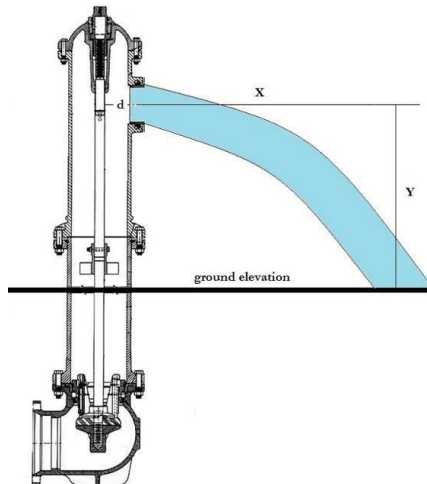



# Determining Hydrant Flows

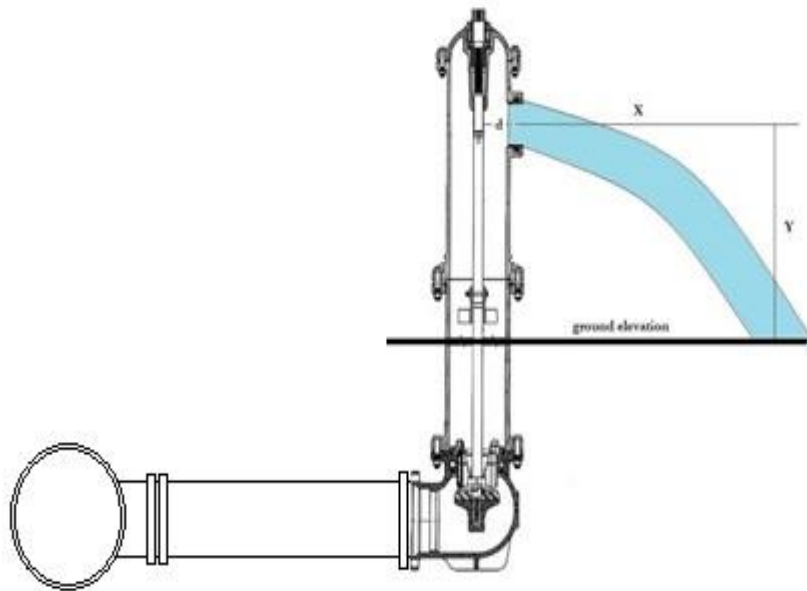

- Flow measurement is from hydrant, not the water main
- Can use hydrant flow to estimate velocity in main lines for scouring practices
- Can use hydrant flows to reduce stagnant conditions and improve water quality
- What flow rate is needed?

# Determining Hydrant Flows

- Estimate flow from equation
  - Distance (X) and height (Y) from hydrant base
  - Nozzle diameter (d)

$$Q, gpm = \frac{2.83d^2 X}{Y^{0.5}}$$

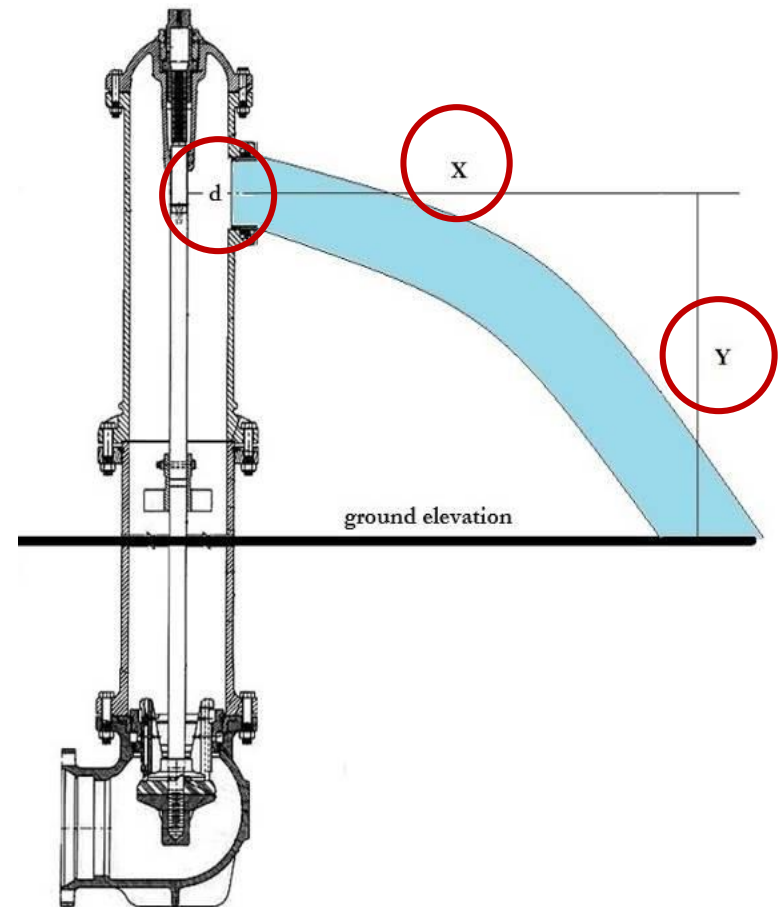

# Determining Hydrant Flows

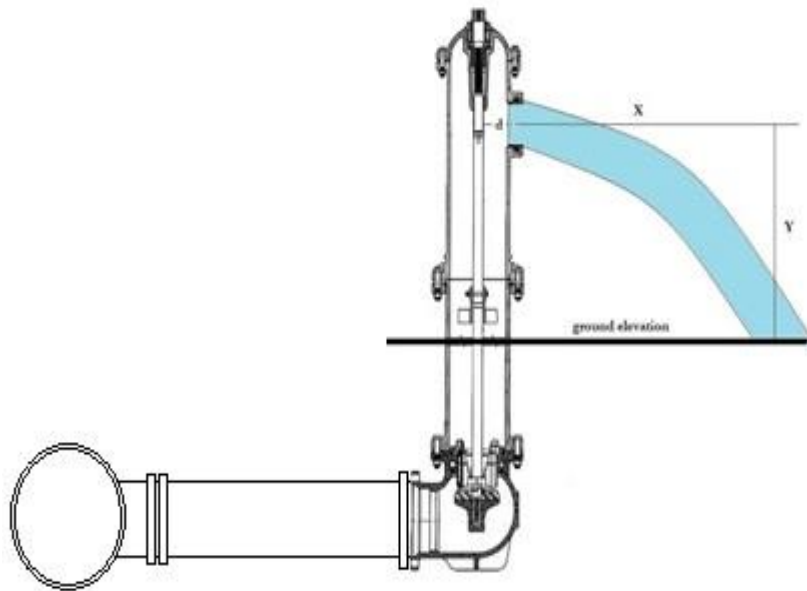

- Assuming **4-inch** nozzle,
  - $X=30$ -inches
  - $Y = 18$ -inches
  - Hydrant flow is  $\sim 320$  gpm
- Assuming main is 8-inch diameter
  - Velocity in main is 1.86 ft/sec
  - This is **NOT** scouring velocity

# Determining Hydrant Flows

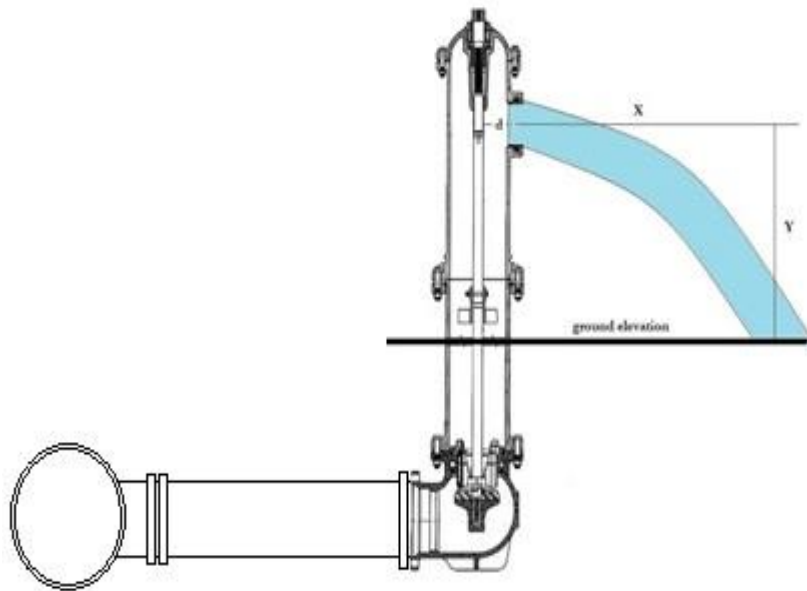

- Assuming 2.5-inch nozzle,
  - $X=30$ -inches
  - $Y = 18$ -inches
  - Hydrant flow is  $\sim 125$  gpm
- Assuming main is 8-inch diameter
  - Velocity in main is  $0.73$  ft/sec
  - This is **NOT** scouring velocity

# Determining Hydrant Flows

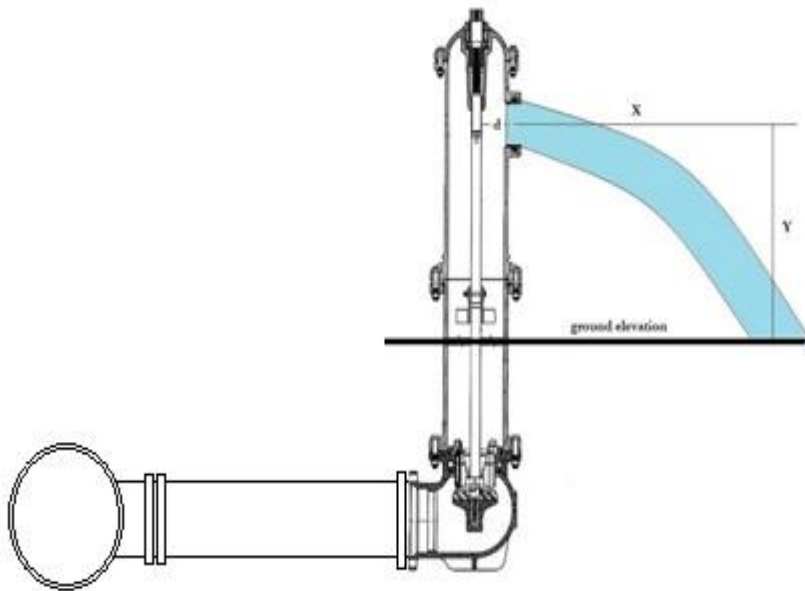

4-inch nozzle diameter <b>150 gpm</b>		
Y	X	gpm
6	8	148
9	10	151
12	12	157
15	13	152
18	14	149
21	15	148
24	16	148
27	17	148
30	18	149

# Determining Hydrant Flows

2.5-inch nozzle diameter <b>150 gpm</b>		
Y	X	gpm
6	21	152
9	26	153
12	30	153
15	33	151
18	36	150
21	39	151
24	42	152
27	44	150
30	47	152

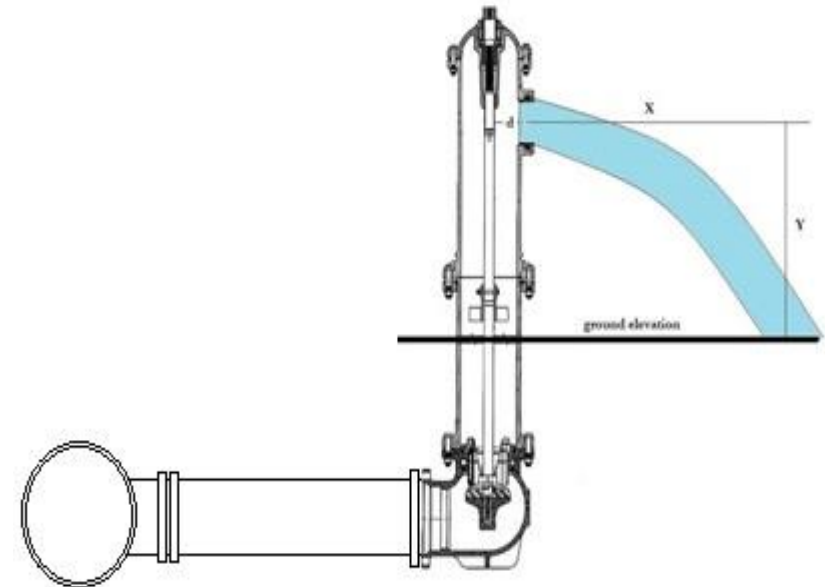

# Determining Hydrant Flows

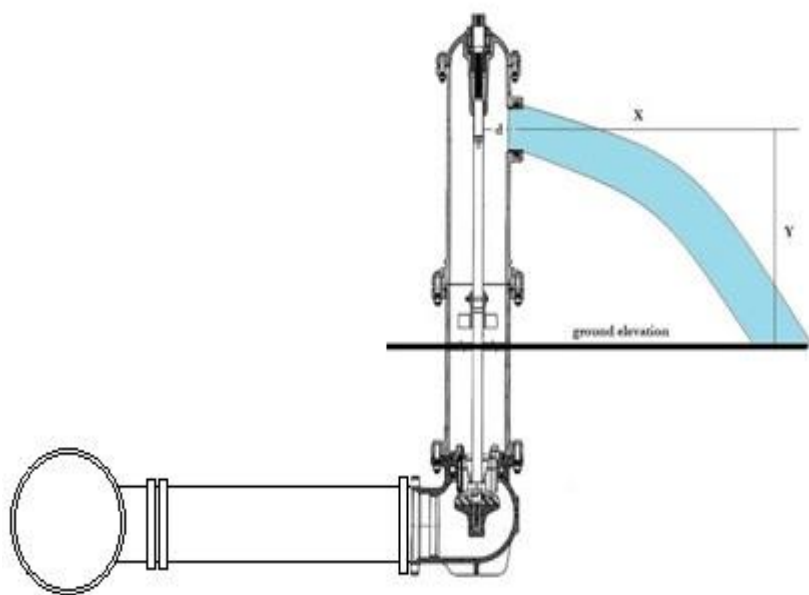

4-inch nozzle diameter <b>250 gpm</b>		
Y	X	gpm
6	14	259
9	17	257
12	19	248
15	22	257
18	24	256
21	26	257
24	27	250
27	29	253
30	30	248



# Determining Hydrant Flows

2.5-inch nozzle diameter <b>250 gpm</b>		
Y	X	gpm
6	35	253
9	42	248
12	49	250
15	55	251
18	60	250
21	65	251
24	70	253
27	73	248
30	77	249

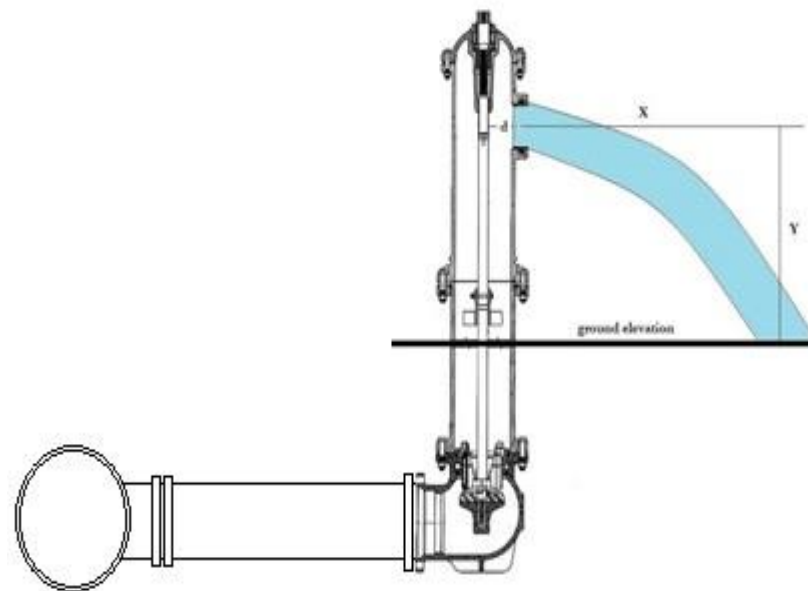

# Determining Hydrant Flows

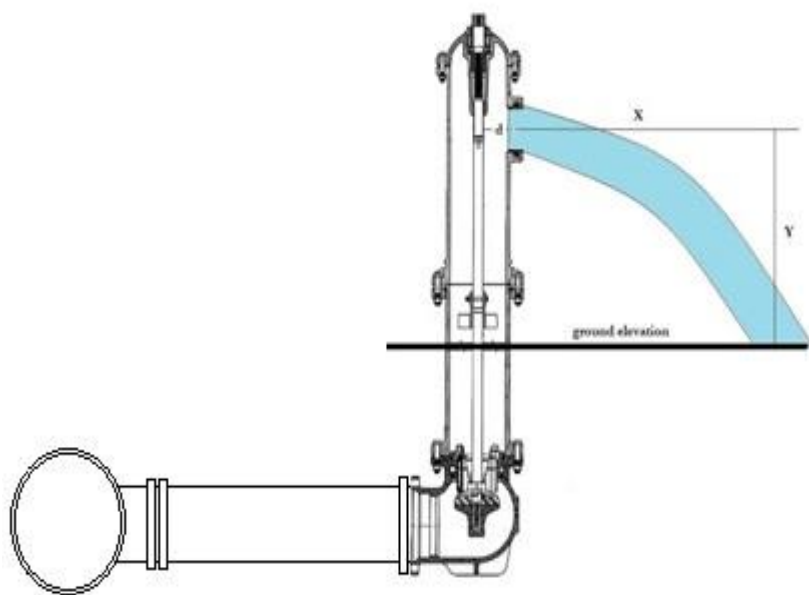

4-inch nozzle diameter <b>350 gpm</b>		
Y	X	gpm
6	19	351
9	23	347
12	27	353
15	30	351
18	33	352
21	36	356
24	38	351
27	40	349
30	42	347

# Determining Hydrant Flows

2.5-inch nozzle diameter <b>350 gpm</b>		
Y	X	gpm
6	35	253
9	42	248
12	49	250
15	55	251
18	60	250
21	65	251
24	70	253
27	73	248
30	77	249

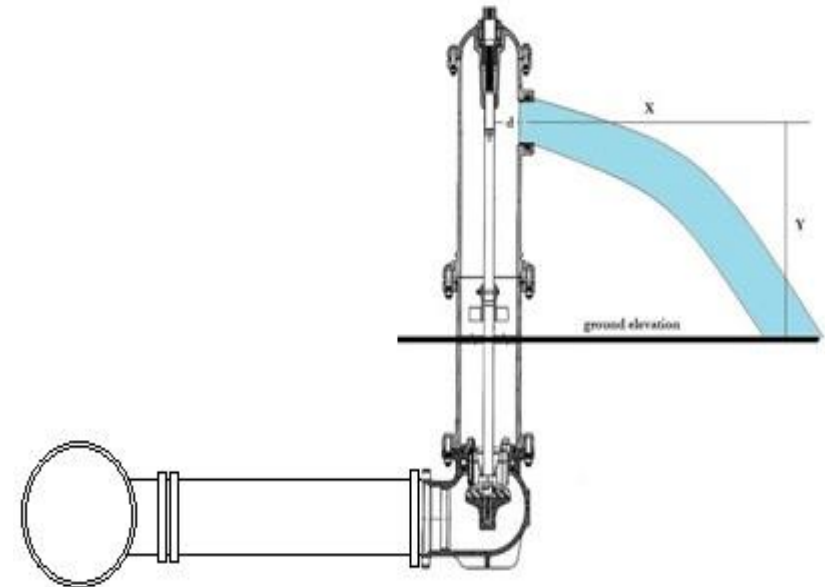

# Determining Hydrant Flows

A **6-inch** water main needs 3.5 ft/sec velocity for scouring. What flow is needed through a **4-inch** fire hydrant nozzle to achieve the main velocity?

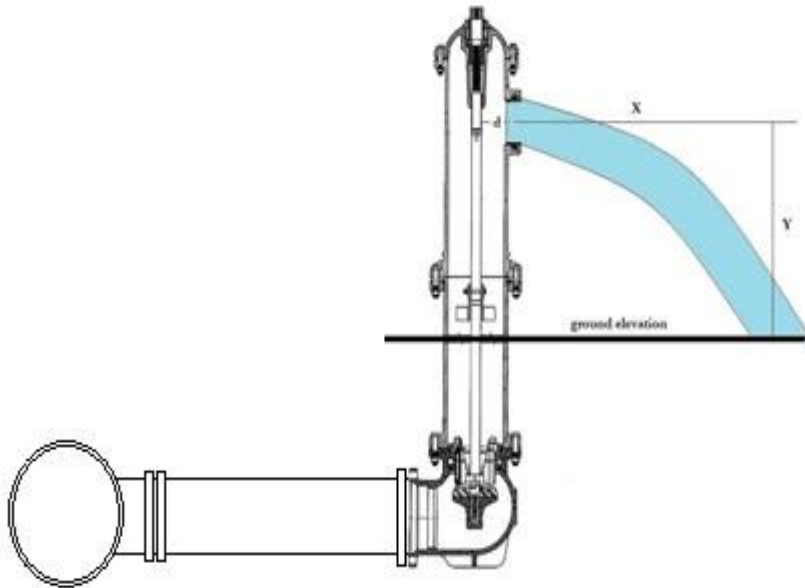

# Determining Hydrant Flows

A **6-inch** water main needs 3.5 ft/sec velocity for scouring. What flow is needed through a **4-inch** fire hydrant nozzle to achieve the main velocity?

**6-inch main diameter**

6.28-inches (0.523 ft)

$$\text{Area} = 0.785d^2 = 0.785(0.523 \text{ ft})^2 = 0.215 \text{ ft}^2$$

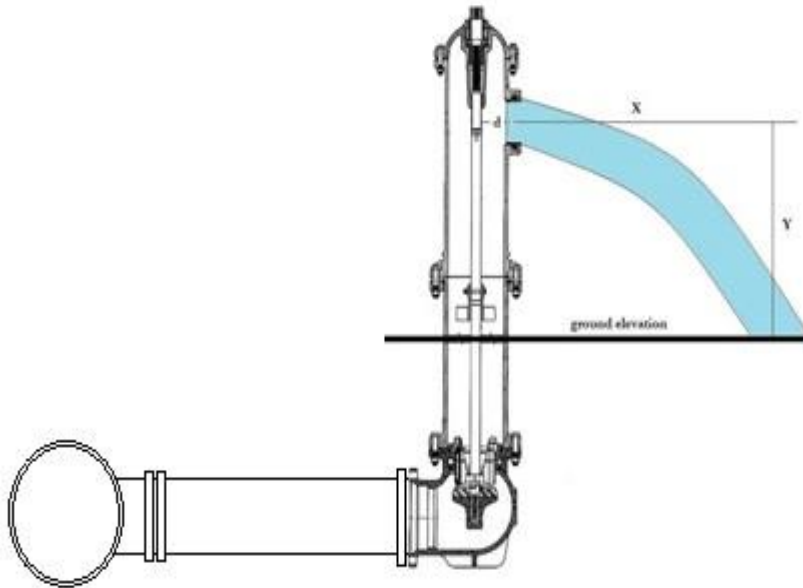

# Determining Hydrant Flows

A **6-inch** water main needs 3.5 ft/sec velocity for scouring. What flow is needed through a **4-inch** fire hydrant nozzle to achieve the main velocity?

6-inch main diameter

6.28-inches (0.523 ft)

$$\text{Area} = 0.785d^2 = 0.785(0.523 \text{ ft})^2 = 0.215 \text{ ft}^2$$

$$Q = AV$$

$$Q = 0.215 \text{ ft}^2 * 3.5 \text{ ft/sec} = 0.753 \text{ ft}^3/\text{sec}$$

$$0.753 \text{ ft}^3/\text{sec} * 7.48 * 60 =$$

**338 gpm**

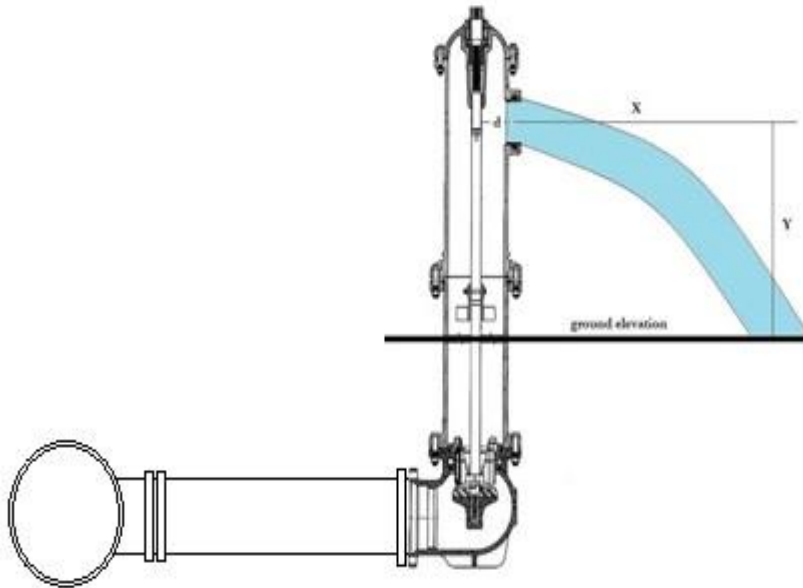

# Determining Hydrant Flows

A **6-inch** water main needs 3.5 ft/sec velocity for scouring. What flow is needed through a **4-inch** fire hydrant nozzle to achieve the main velocity?

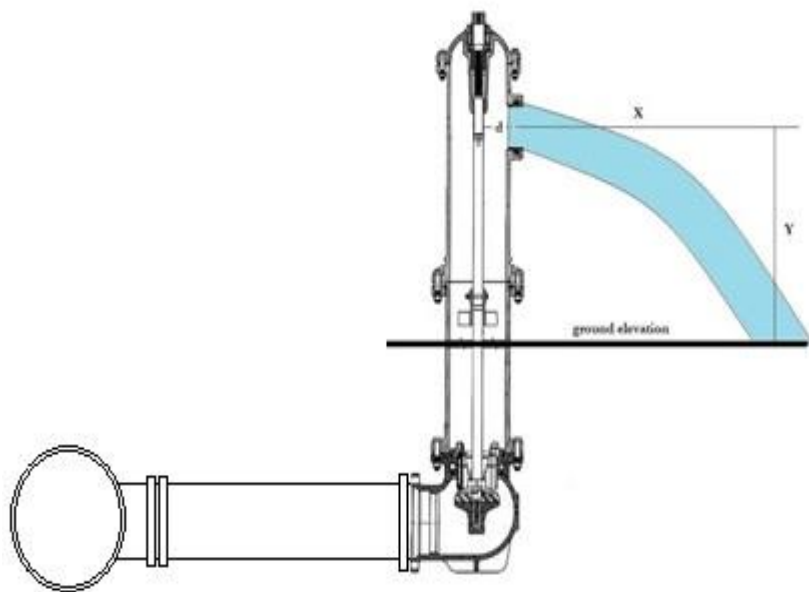

4-inch nozzle diameter		
Y	X	gpm
6	19	351
9	23	347
12	26	340
15	29	339
18	32	342
21	34	336
24	37	342
27	39	340
30	41	339



# Determining Hydrant Flows

A **6-inch** water main needs 3.5 ft/sec velocity for scouring. What flow is needed through a **4-inch** fire hydrant nozzle to achieve the main velocity?

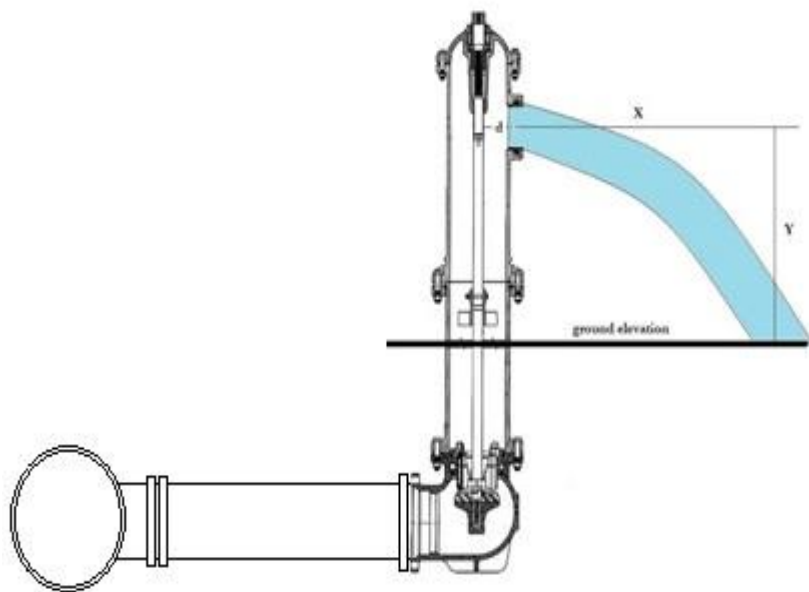

4-inch nozzle diameter		
Y	X	gpm
6	19	351
9	23	347
12	26	340
15	29	339
18	32	342
21	34	336
24	37	342
27	39	340
30	41	339

# Determining Hydrant Flows

A **12-inch** water main needs 3.5 ft/sec velocity for scouring. What flow is needed through a **4-inch** fire hydrant nozzle to achieve the main velocity?

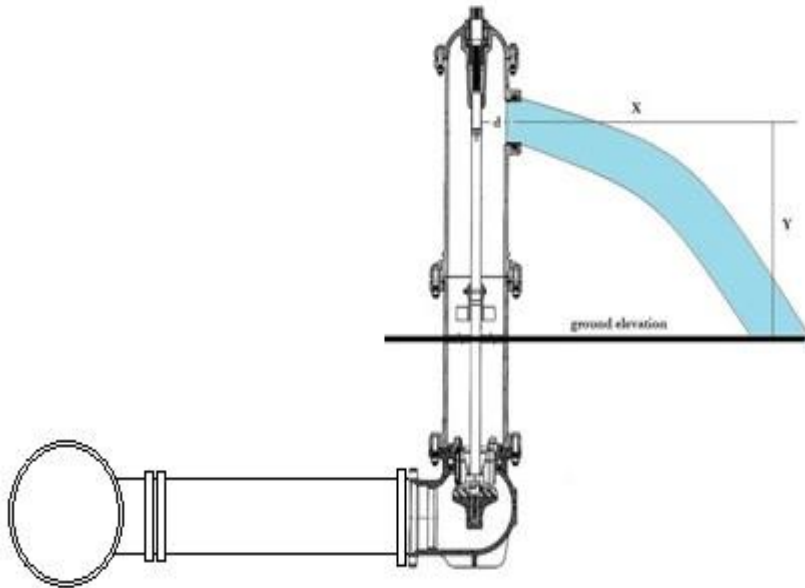

# Determining Hydrant Flows

A **12-inch** water main needs 3.5 ft/sec velocity for scouring. What flow is needed through a **4-inch** fire hydrant nozzle to achieve the main velocity?

**12-inch main diameter**

12.46-inches (1.038 ft)

$$\text{Area} = 0.785d^2 = 0.785(1.038 \text{ ft})^2 = 0.846 \text{ ft}^2$$

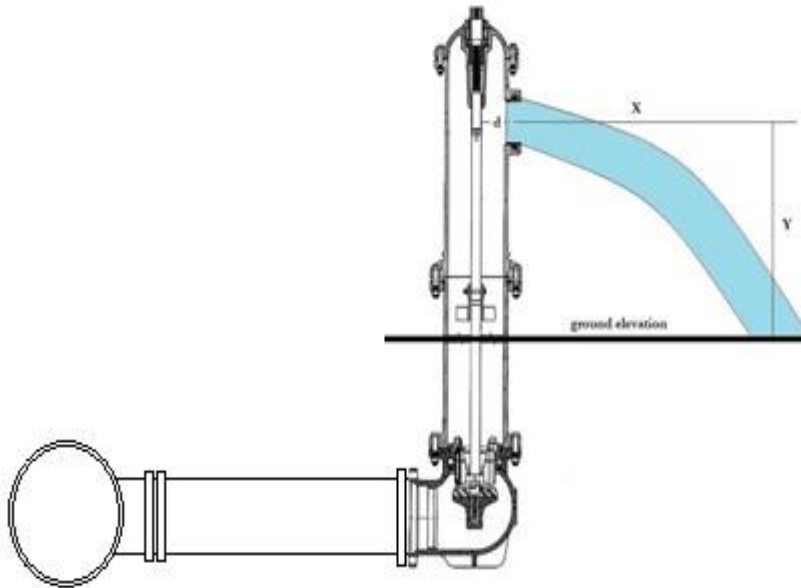

# Determining Hydrant Flows

A **12-inch** water main needs 3.5 ft/sec velocity for scouring. What flow is needed through a **4-inch** fire hydrant nozzle to achieve the main velocity?

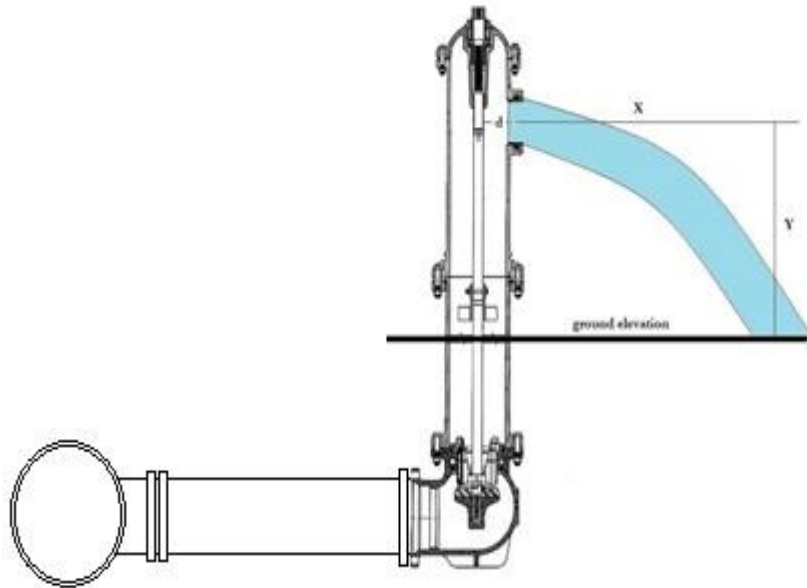

**12-inch main diameter**

12.46-inches (1.038 ft)

$$\text{Area} = 0.785d^2 = 0.785(1.038 \text{ ft})^2 = 0.846 \text{ ft}^2$$

$$Q = AV$$

$$Q = 0.846 \text{ ft}^2 * 3.5 \text{ ft/sec} = 2.961 \text{ ft}^3/\text{sec}$$

$$2.961 \text{ ft}^3/\text{sec} * 7.48 * 60 =$$

**1,329 gpm**

# Determining Hydrant Flows

A **12-inch** water main needs 3.5 ft/sec velocity for scouring. What flow is needed through a **4-inch** fire hydrant nozzle to achieve the main velocity?

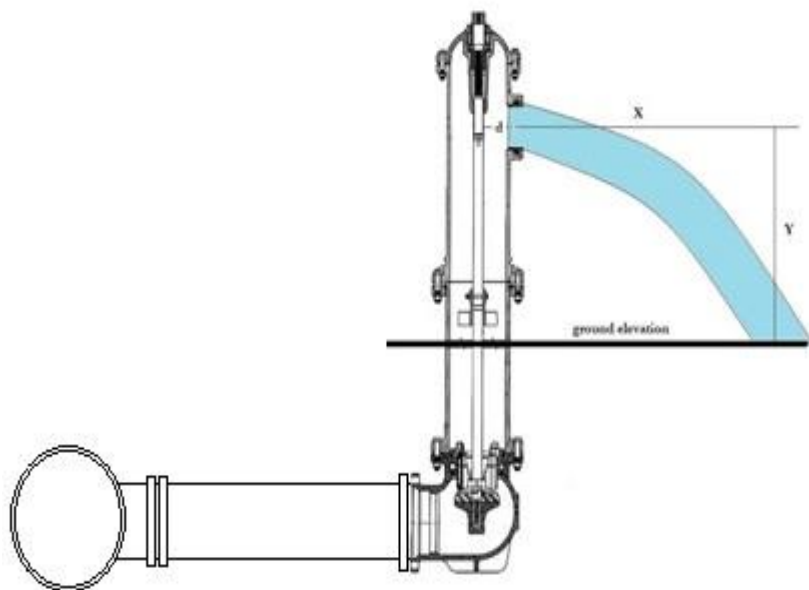

4-inch nozzle diameter		
Y	X	gpm
6	72	1,331
9	88	1,328
12	102	1,333
15	114	1,333
18	125	1,334
21	135	1,334
24	144	1,331
27	153	1,333
30	161	1,331

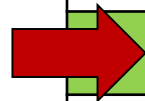

# Determining Hydrant Flows

A **12-inch** water main needs 3.5 ft/sec velocity for scouring. What flow is needed through a **4-inch** fire hydrant nozzle to achieve the main velocity?

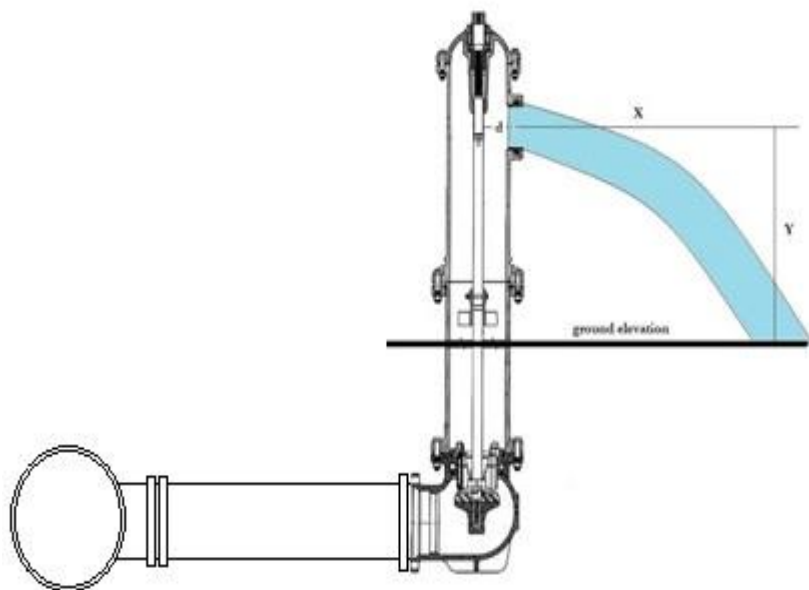

4-inch nozzle diameter		
Y	X	gpm
6	72	1,331
9	88	1,328
12	102	1,333
15	114	1,333
18	125	1,334
21	135	1,334
24	144	1,331
27	153	1,333
30	161	1,331

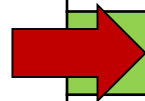

# Determining Hydrant Flows

An **8-inch** water main needs water quality maintenance flushing at **250 gpm** using the **2.5-inch** nozzle. What velocity is achieved the 8-inch main during flushing?

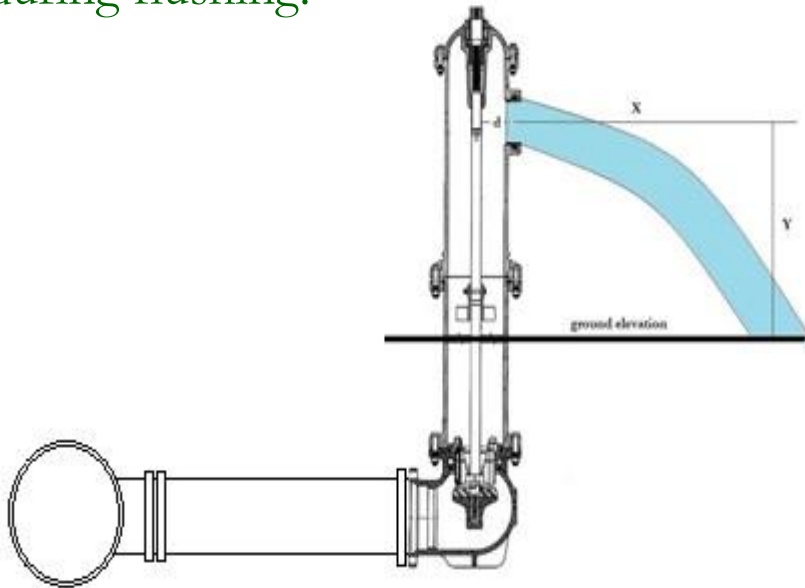



# Determining Hydrant Flows

An **8-inch** water main needs water quality maintenance flushing at **250 gpm** using the **2.5-inch** nozzle. What velocity is achieved the 8-inch main during flushing?

**8-inch diameter**

8.39-inches (0.699 ft)

$$\begin{aligned} \text{Area} &= 0.785d^2 = 0.785(0.699 \text{ ft})^2 \\ &= 0.351 \text{ ft}^2 \end{aligned}$$

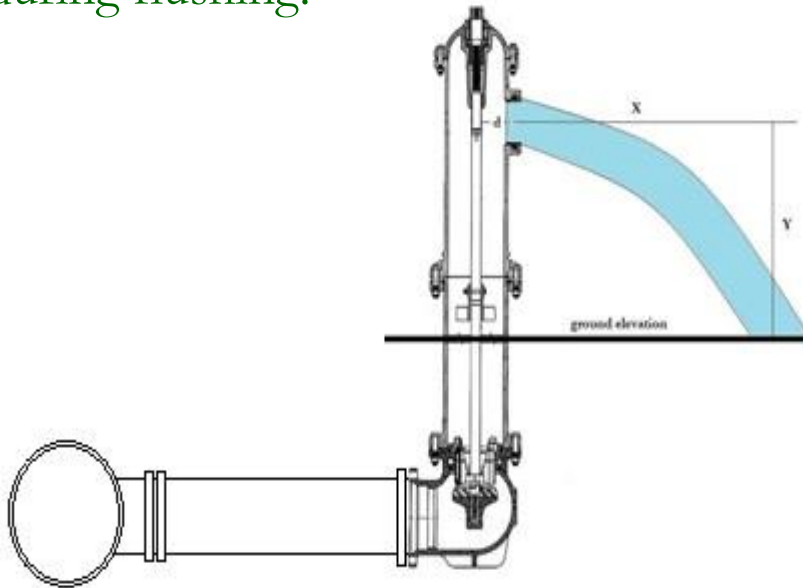

# Determining Hydrant Flows

An **8-inch** water main needs water quality maintenance flushing at **250 gpm** using the **2.5-inch** nozzle. What velocity is achieved the 8-inch main during flushing?

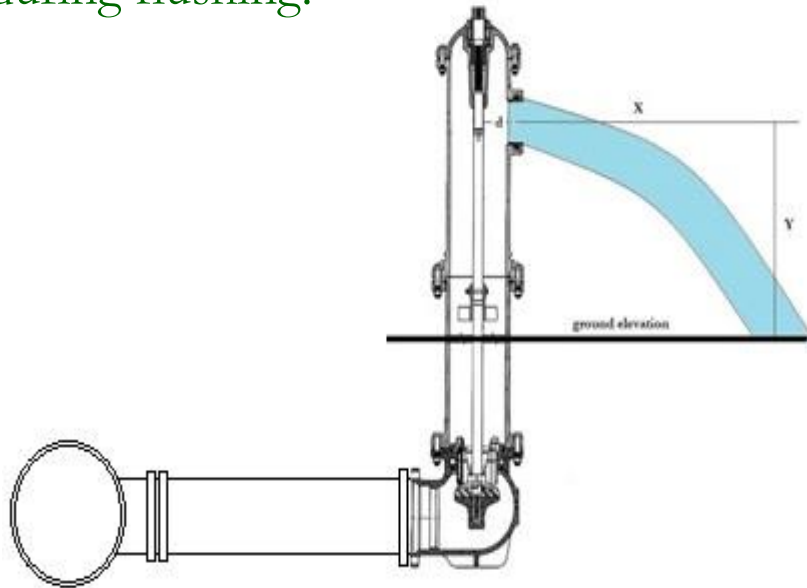

**8-inch diameter**

8.39-inches (0.699 ft)

$$\text{Area} = 0.785d^2 = 0.785(0.699 \text{ ft})^2 = 0.351 \text{ ft}^2$$

$$Q = AV$$

$$Q = 250 \text{ gpm} / 7.48 / 60 = 0.557 \text{ ft}^3/\text{sec}$$

$$0.557 \text{ ft}^3/\text{sec} / 0.351 \text{ ft}^2 =$$

$$\mathbf{1.59 \text{ ft/sec}}$$

**Is this a scouring velocity?**

# Proper Flushing Areas

- Areas that benefit from water quality maintenance flushing
  - 12-inch and smaller mains
  - Dead end mains
  - Areas with only one feeder main
  - Areas with low flows and low water demands
  - Farthest ends of the system
- Mains 14-inch and larger generally are transmission mains and normally do not develop heavy scale formations



# Proper Flushing Areas

- Select areas where hydrant flow can be dispersed to drain away
  - Take care to avoid lawn damage
  - Take care to avoid flooding zones in traffic
  - Take care to avoid overloading sewers
  - Remember dechlorination procedures as necessary



# Flushing and Residual Maintenance

- Plan the flushing areas ahead of time
  - Divide system into flushing zones
  - Map out zones and select hydrants or hydrant numbers
    - Not every hydrant needs to be flushed
  - Flush from fresher water outward toward extremities
    - Most common to start near treatment plant or point-of-entry (POE) and work outward
  - Flush from larger pipes to smaller pipes
    - Large mains typically are not flushed due to normal water demands
- Continue with each flushing zone until all problem areas are completed

# Flushing and Residual Maintenance

TABLE SOUTHWESTERN 2015 FLUSHING PLAN							
	Location	Hydrant Number	Feet of Main Flushed		Location	Hydrant Number	Feet of Main Flushed
1	Octave Way	D990	1,750	24	McCartney Street	D2433	2,375
2	Plyer Way	D475	500	25	Arnold Street	D729	1,250
3	Plyer Way	D329	2,250	26	Steuben Street	D877	1,750
4	Olympia St. at Grandview Ave.	D285	3,250	27	Berdella Street	D691	500
5	Fetterman Way	D921	1,250	28	Herschel Street	D717	1,500
6	Wyola Street	D455	1,500	29	Herschel Street	D332	1,250
7	Augusta Street	D333	1,000	30	W. End Park Dr.	D616	600
8	Augusta Street	D923	1,250	31	Kerr Street	D523	1,250
9	Shaler Street	D507	625	32	Harker Street	D823	1,000
10	Grandview Ave.	D295	2,000	33	Calcutta Way	D689	2,000
11	Republic Street	D467	2,250	34	Calcutta Way	D230	875
12	Fingal Street	D394	1,750	35	Gelston Street	D695	1,250
13	Horner Street	D468	2,250	36	Ironside Way	D705	2,250
14	Greentree Road	D2172	0	37	No Name	D701	2,000
15	Greentree Road	D2225	3,000	38	Comstock Way	D712	1,750
16	Rhoda Island Street	D846	1,500	39	Valonia Street	D806	1,750
17	Ridgemont Drive	D916	1,500	40	Lakewood Street	D742	1,250
18	Adolph Street	D842	1,250	41	Lakewood Street	D744	1,500
19	McCartney Street	D815	1,250	42			
20	Wittman Street	D655	2,000				
21	Jerome Street	D2256	1,000				
22	Oak Brook Circle	D2169	1,000				
23	Queensbury Street	D665	1,125				

# Flushing and Residual Maintenance

## ■ Develop Flushing Logs

- Coordinate logs with the flushing zones
- Record information
  - Date
  - Hydrant location and number (as appropriate)
  - Initial disinfectant residual, mg/L
  - Hydrant flow rate, gpm
  - Flushing duration, minutes
  - Final disinfectant residual, mg/L
  - Other water quality parameters as needed (UV absorbance, pH, others)
  - Note observations like red water for first 3 minutes, white water for first 2 minutes, hydrant not operable, etc.

# Flushing and Residual Maintenance

- **Residual Monitoring**
  - Collect sample and measurement as soon as water initially clears
  - Flush at 10-minute intervals and collect residuals measurements
  - Continue flushing until residual stabilizes
    - Two consecutive readings within 0.2 mg/L free chlorine
    - Two consecutive readings within 0.4 mg/L total chlorine
  - Record residual measurements and flushing duration on logs







# Flushing and Residual Maintenance

## Hydrant Flushing, Aux. Valve Exercising

Block # 9

American Water EPA  
Operator(S) JA

	1	2	3	4	5
Date	4-8-19	4-8-19	4-8-19	4-8-19	4-8-19
Time					
Location	535 Runnymede St	Runnymede St	2789 Tuscany Ct	Tuscany Ct	782 Runnymede St
Hydrant #	321	320	252	253	92
Year	1989	?	2006	2006	2003
Make	Muellev	Glow	Clow	Clow	Clow
Model	ACA	950	960	960	950
# 2.5 Ports	2	1	2	2	1
# 4.5 Ports	1	1	1	1	1
Comments	Dry	wet	wet	wet	wet
Valve #	1070	1069	?	?	493
Exercise Y/N	Yes	Yes	<del>26</del> Yes	Yes	N
# of Turn	19	19	26	26	N/A
Vac. Y/N	N	N	N	N	N/A
Comments					
Hydrant PSI	58	60	60	62	60
Pre TCL2	2.1	2.9	1.0	2.25	350/10-1.8
Pitot GPM	750	840	720	840	350
Pitot PSI	20	38-25	20	25	10
Water Color	Brc	Brc	Brc	Brc	Brc
Post TCL2	2.6	3.8	2.8	2.84	2.81
Flush Time	10 min	10 min	10 min	10 min	10 min
Total Gal.	7500	8400	7200	8400	3500
Comments					

Water Color Codes – BrC (Brown to Clear), BIC (Black to Clear), AC (All Clear)

Flushing Block Order: (1) North EPA - 5, 2, 4, 3, 6 / (2) Central EPA - 9, 8, 7, 10, 11 / (3) South EPA - 12, 13, 14, 15, 16, 17, 18

# Flushing and Residual Maintenance

- **Generally, increases disinfectant residuals**
  - Up to 500% increase in residuals observed
  - Flush until acceptable residuals obtained
- **Removes stagnant water from system**
  - Reduces water age
  - Reduces UV absorbance values and organic levels
  - Rids colored water issues in most cases
- **Removed excess biofilms**
  - Lowers HPC counts
- **Not a substitute for scouring / cleaning mains**



# Practical Uses for UVA Monitoring

## Distribution System Monitoring

Sample Site	UVA before flushing	UVA after flushing
1	0.038	
2	0.039	
3	0.040	
4	0.034	
5	0.037	
6	0.032	
7	0.043	
8	0.048	

# Practical Uses for UVA Monitoring

## Distribution System Monitoring

Sample Site	UVA before flushing	UVA after flushing
1	0.038	0.024
2	0.039	0.026
3	0.040	0.026
4	0.034	0.016
5	0.037	0.024
6	0.032	0.026
7	0.043	0.024
8	0.048	0.027

# Practical Uses for UVA Monitoring

## Distribution System Monitoring

38.5% reduction in organic content after flushing – removal of biofilms and excess chlorine demand

Sample Site	UVA before flushing	UVA after flushing
1	0.038	0.024
2	0.039	0.026
3	0.040	0.026
4	0.034	0.016
5	0.037	0.024
6	0.032	0.026
7	0.043	0.024
8	0.048	0.027

# Recordkeeping

- Important for historical reasons and costing
  - Maintains list of hydrants flushed
  - Maintains flushing duration for comparison each year
    - Can estimate annual flushing volumes and water costs used for maintenance
  - Maintains record of disinfectant residual maintenance and concentrations achieved
  - Maintains other water quality observations (color, odors, etc.)



# Recordkeeping

- **Tabulated annual flushing volume for actual large system**
  - 782 hydrants used
  - Average flushing time 25 minutes
  - Average flows rate 150 gpm
  - 2,933,000 gallons used for flushing
- **Flushing water**
  - Cost may range from \$0.35 per 1,000 gallons to \$0.85 per 1,000 gallons
    - Chemicals and power
  - Annual cost for large water system at \$0.54 per 1,000 gallons



# Recordkeeping

- **Tabulated annual flushing volume for actual large system**
  - 782 hydrants used
  - Average flushing time 25 minutes
  - Average flows rate 150 gpm
  - 29,330,000 gallons used for flushing
- **Flushing water**
  - Cost may range from \$0.35 per 1,000 gallons to \$0.85 per 1,000 gallons
    - Chemicals and power
  - Annual cost for water at \$0.54 per 1,000 gallons
    - \$15,840
    - Removed from annual unaccounted for water figures since its purpose was dedicated to system maintenance



# *Questions*

**Marvin Gnagy**

**[pmgconsulting@gmail.com](mailto:pmgconsulting@gmail.com)**

**419.450.2931**