



## 2024 NGS -DIXIE LATE MODEL DIVISION RULES



PACKAGE	ENGINE	WEIGHT	SPOILER
A	604 CRATE ENGINE	2200 #	8" SPOILER
B	ENGINE RULE	2300#	8" SPOILER
C	ENGINE RULE	2400#	8" SPOILER
D	GM/CT 525	2350#	8" SPOILER
E	NLMS	2300#	8" SPOILER
F	NLMS	2350#	8" SPOILER
G	358 SPUR HEAD ENGINE	2400#	8" SPOILER
H	TOPLESS OUTLAW	2450#	8" SPOILER
I	OPEN MOTOR MUST RUN A 1.00 RESTRICTOR PLATE ON OPEN ENGINE WILL TECH NIGHTLY	1400#	8" SPOILER

### ENGINE PACKAGE A:

1- GM P/N# 19318604-350 COD / 400HP

2-GM ENGINE MAY BE PURCHASES AT ANY GM DEALER

3- THE SEALED ENGINE MUST REMAIN INTACT AND NOT BE TAMPERED WITH: ANY SEALS THAT HAVE BEEN REMOVED OR TAMPERED WILL MAKE ENGINE ILLEGAL AND NOT ELIGIBLE FOR COMPETITION AT NORTH GEORGIA SPEEDWAY

4-NO CHANGES ARE ALLOWED TO THE ENGINE(INTAKE, MANIFOLD,HEADS,VALVE COVERS,OIL PAN HARMONIC BALANCER OR ANY OTHER PART/OR PARTS ON/OR IN THE ENGINE.CRATE ENGINES MUST NOT BE ALTERED, MODIFIED OR CHANGED FROM FACTORY SPECS

5- NO VACUUM PUMPS

6- ALL CRATE ENGINE MUST BE SEALED WITH FACTORY GM SEAL BOLTS OR CRATE USA SEALS WE WILL ALLOW OTHER SERIES SEALS IF WE CAN VERIFY THE SEAL SUSTEM OF OTHER SERIES

### CRANKING COMPRESSION:

1- ALL CRATE ENGINES WILL HAVE A MAXIMUM PRESSURE OF 200PSI, ANY ENGINE THAT HAS OVER 200 PSI WILL BE ILLEGAL



## **ENGINE PACKAGE B: BLOCK**

- 1- CAST IRON V-8 BLOCK ONLY
- 2- MAXIMUM CYLINDER BORE SIZE, CHEVROLET 4.060. FORD 4.060. CHRYSLER 4.060
- 3-AFTER MARKET STEEL SPLAYED MAIN CAPS PERMITTED
- 4-MAIN CAP STUDS AND STRAPS PERMITTED
- 5- DEBURRING BLOCK AND PLUGGING DECK TO STRENGTHEN BLOCK PERMITTED
- 6-PLUG OR VENT & SCREEN OIL DRAIN HOLES IN LIFTER VALLEY PERMITTED
- 7-MAY SURFACE BLOCK
- 8-LIFTER BORE MUST BE OEM DIAMETER FOR ENGINE- GM 840 / FORD 875 / CHRYSLER

## **CRANK**

- 1- ANY STEEL CRANK WITH THE EXCEPTION OF (NO PENDULUM UNDERCUT COUNTERWEIGHTS AND TITANIUM OR OTHER EXOTIC MATERIALS)
- 2-MUST BE STANDARD STROKE FOR ENGINE – GM 3.48 / FORD 3.50 / CHRYSLER 3.58
- 3-MAY BALANCE ENGINE

## **RODS**

- 1-STEEL RODS ONLY
- 2-NO TITANIUM OR ALUMINUM RODS

## **PISTONS**

- 1- ANY FLAT TOP PISTON & PINS
- 2- NO DOME PISTONS

## **CAM**

- 1-SOLID LIFT CAM ONLY
- 2- NO ROLLER, MUSHROOM OR RADIUS CAMS



## **ENGINE PACKAGE B:**

### **LIFTERS**

1-SOLID LIFTER ONLY

2-NO ROLLER, MUSHROOM OR RADIUS LIFTERS

3-LIFTER TRAY PERMITTED

4-LIFTERS MUST BE OEM DIAMETER FOR ENGINE- GM .840 / FORD .875 / CHRYSLER .901

### **HEADS**

THESE ARE THE ONLY HEADS PERMITTED:

1- OEM CAST IRON STRAIGHT PLUG HEADS – CHEVROLET BOWTIE CAST IRON HEADS  
CHEVROLET BOWTIE VORTEC HEADS – DART EAGLE CAST IRON HEADS  
WORLDS PRODUCTS SPORTSMAN II CAST IRON HEADS  
FORD SVO SPORTSMAN CAST IRON HEAD  
CHRYSLER CAST IRON HEADS

2- ANY 23 DEGREE CAST IRON HEAD NOT LISTED ABOVE MUST BE APPROVED BY NGS FOR THIS ENGINE PACKAGE – HEADS MAY BE SUBJECT TO A 50# WEIGHT PENALTY

3- ALL HEADS MUST REMAIN AS-CAST

4-NO CC LIMIT

5-VALVE ANGLE AND SPACING MUST REMAIN ORIGINAL PRODUCTION SPECS FOR HEADS BEING USED

6-STEEL VALVES ONLY (NO TITANIUM VALVE)

7-VALVE SIZE MAXIMUM (B) ENGINE - INTAKE 1.020 / EXHAUST 1.6

8-VALVE STEM DIAMETER 11/32 MINIMUM FOR ALL ENGINES

9-UNDERCUT STEMS PERMITTED, ANY TYPE OF GUIDES

10-ANY VALVE SPRING , RETAINERS AND KEEPERS

11- GUIDES PLATES, SCREWS IN STUDS AND STUD GIRDLES PERMITTED

12-ROLLER ROCKER ARMS, STUDS OR SHAFT MOUNTED PERMITTED



## **ENGINE PACKAGE B:**

### **HEADS CONT:**

13-NO PORTING OR POLISHING, ALL HEADS MUST REMAIN AS –CAST

14-NO PORT MATCHING INTAKE OR EXHAUST RUNNERS

15-RACING VALVES JOB PERMITTED MACHINE CUT ONLY

16-NO BLENDING VALVE JOB TO CASTING NO DEBURRING INTAKE OR EXHAUST RUNNERS

### **TIMING CHAIN:**

1-ANY CHAIN & GEARS – NO GEAR OR BELT DRIVES

### **WATERPUMP:**

1-NO ELECTRIC WATERPUMP, CAST OF ALUMINUM PERMITTED

### **OIL SYSTEM:**

1-WET SUMP SYSTEMS, INTERNAL OR EXTERNAL PUMPS PERMITTED

2-DRY SUMP OIL SYSTEMS PERMITTED UST ADD ADDITIONAL 50#

### **FUEL SYSTEM:**

1- NO ELECTRIC PUMPS

### **DISTRIBUTOR:**

1-ANY IGNITION WITH EXCEPTION OF MAGNETOS (NO MAGNETOS PERMITTED)

### **CARBURETOR:**

1- (1) FOUR BARREL CARBURETOR ONLY OF ANY MANUFACTURER

2-NO TURBOS , BLOWERS OR FUEL INJECTORS

3-ALL ENGINES MUST BE NATURALLY ASPRIRATED

### **INTAKE:**

1-ANY SINGLE FOUR BARRLE INTAKE PERMITTED

2-MAY PORT & POLISH

3-ANY SIZE CARBURETOR SPACER PERMITTED



## **ENGINE PACKAGE C:** **BLOCK**

- 1- CAST IRON V-8 BLOCK ONLY
- 2- MAXIMUM CYLINDER BORE SIZE, CHEVROLET 4.060. FORD 4.060. CHRYSLER 4.060
- 3- AFTER MARKET STEEL SPLAYED MAIN CAPS PERMITTED
- 4- MAIN CAP STUDS AND STRAPS PERMITTED
- 5- DEBURRING BLOCK AND PLUGGING DECK TO STRENGTHEN BLOCK PERMITTED
- 6- PLUG OR VENT & SCREEN OIL DRAIN HOLES IN LIFTER VALLEY PERMITTED
- 7- LIFTER BORE MAY BE OVERSIZED
- 8- 362.5 CUBIC INCH MAXIMUM FORD & CHEVROLET
- 9- 371.0 CUBIC INCH MAXIMUM CHRYSLER

## **CRANK.**

- 1- ANY STEEL CRANK WITH THE EXCEPTION OF TITANIUM OR OTHER EXOTIC MATERIALS
- 2- 3.500 MAXIMUM STROKE FOR FORD & CHEVROLET
- 3- 3.5800 MAXIMUM STROKE FRO CHRYSLER
- 4- 362.5 CUBIC INCH MAXIMUM FOR FORD & CHEVROLET
- 5- 371.00 CUBIC INCH MAXIMUM CHRYSLER

## **RODS**

- 1- STEEL RODS ONLY
- 2- NO TITANIUM OR ALUMINUM RODS

## **PISTONS**

- 1- ANY PISTON & PINS



## ENGINE PACKAGE C:

### CAM

1-SOLID LIFT CAM ONLY

2- NO ROLLER, MUSHROOM OR RADIUS CAMS

### LIFTERS

1-LIFTER RETAINING TRAY PERMITTED

4-LIFTERS MUST BE OEM DIAMETER FOR ENGINE- GM .840 / FORD .875 / CHRYSLER .901

### HEADS

THESE ARE THE ONLY HEADS PERMITTED:

**1a-** ANY CHEVROLET 23 DEGREE BOWTIE CAST IRON HEADS- BOWTIE –PRO ACTION – TOP RACING HEAD SERVICE (RHS) HEADS

SPARK PLUG LOCATION MUST BE THE SAME AS THE BOWTIE & DART HEADS

**1b-** FORD SVO SPORTSMAN CAST IRON HEADS - M-6049-E351 AND M-6049-N352  
GT40-P WORLD PRODUCTS WINDSOR SR – PRO ACTION/ PRO LINE / RACING HEAD SERVICE (RHS)

**1c-** CHRYSLER – CAST IRON W-2

**2-** ALL HEADS MUST REMAIN AS – CAST

**3-** NO CC LIMITS

**4-** VALVE ANGLE & SPACING MUST REMAIN ORIGINAL PRODUCTION SPECS FROM HEAD BEING USED

**5-** STEEL VALVE ONLY ( NO TITANIUM VALVES)

**6-** VALVE SIZE MAXIMUM FROM C ENGINE – INTAKE 2.055 / EXHAUST – 1.625

**7-** VALVE STEM DIAMETER 11/32 MINIMUM ALL ENGINES

**8-** UNDER CUT STEMS PERMITTED, ANY TYPE GUIDES

**9-** ANY VALVE SPRING, RETAINERS & KEEPERS

**10-** GUIDE PLATES , SCREW IN STUDS AND STUD GIRDLES PERMITTED

**11-** ROLLER ROCKER ARMS , STUDS OR SHAFT MOUNTED PERMITTED

**12-** NO PORTING OR POLISHING ALL HEADS MUST REMAIN AS-CAST



## ENGINE PACKAGE C:

### HEADS CONT

- 13-NO SHOT PEEN PORTING HEADS
- 14-NO PORT MATCHING INTAKE OR EXHAUST RUNNERS
- 15-RACING VALVE JOB PERMITTED – MACHINE CUT ONLY
- 16-NO BLEEDING VALVE JOB TO CASTING
- 17-NO DEBURRING INTAKE OR EXHAUST

### INTAKE:

- 1-ANY SINGLE FOUR BARREL INTAKE PERMITTED
- 2-MAY PORT & POLISH
- 3-ANY SIZE CARBURETOR SPACER PERMITTED

### CARBURETOR:

- 1- (1) FOUR BARREL CARBURETOR ONLY OF ANY MANUFACTURER
- 2-NO TURBOS , BLOWERS OR FUEL INJECTORS
- 3-ALL ENGINES MUST BE NATURALLY ASPIRATED

### OIL SYSTEM:

- 1-WET SUMP SYSTEMS, INTERNAL OR EXTERNAL PUMPS PERMITTED

### WATERPUMP:

- 1-NO ELECTRIC WATERPUMP, CAST OF ALUMINUM PERMITTED

### FUEL SYSTEM:

- 1- NO ELECTRIC PUMPS

### DISTRIBUTOR:

- 1-ANY IGNITION WITH EXCEPTION OF MAGNETOS (NO MAGNETOS PERMITTED)

## ENGINE PACKAGE D:



1- GM PART NUMBER 19271821 9CT525)

2-THESE ENGINE ARE SEALED AT CHEVROLET PERFORMANCE , ALL ENGINE MUST HAVE ORIGINAL CHEVROLET PERFORMANCE GM SEALS, ENGINE MUST NOT BE ALTERED, MODIFIED OR CHANGED FROM FACTORY SPECIFICATIONS

3-THE SEALED ENGINE MUST REMAIN INTACT AND NOT BE TAMPERED WITH , ANY SEALS THAT HAVE BEEN REMOVED OR TAMPERED WITH WILL MAKE ENGINE ILLEGAL AND NOT ELIGIBLE FRO COMPETITION. THE PENALTY FRO ANYONE TAMPERING WITH SEALS, MODIFYING AND INTERNAL ENGINE APRT, CHANGING PARTS FRO STOCK AS DELIVERED AND SEALED FROM THE FACTORY WILL BE SUBJECT TO EXPULSION FROM RACING AT NGS

4-CT 525 MUST RUN MSDI-SX IGNITION CONTROLLER, MSD IGNITION CONTROLLER MUST BE MOUNTED WITH EAST OF ACCESS FRO TECH INSPECTOR , MSD IGNITION CONTROLLER MUST BE PROGRAMMED WITH A LIMIT OF 7300 RPM MAXIMUM

5-WHEN CHECKED AFTER RACE, IF RPM LIMIT IS MORE THAT 7300 RPM , THIS WILL RESULT IN DISQUALIFACTION, NO MONEY OR POINTS FOR THAT RACE

6-THE GM / CT525 WILL BE THE ONLY ENGINE ALLOWED TO USE COIL PACK DISTRIBUTORLESS IGNITION SYSTEM

## CARBURETOR:

1-SINGLE FOUR BARREL CARBURETOR ONLY – OF ANY MANUFACTURE

2-ANY SIZE CARBURETOR SPACER PERMITTED





### **ENGINE PACKAGE E:**

SEE NATIONAL LATE MODEL SERIES RULES FOR SPECIFICATION REGARDING ENGINES

### **ENGINE PACKAGE F:**

SEE NATIONAL LATE MODEL SERIES RULES FOR SPECIFICATION REGARDING ENGINES

### **ENGINE PACKAGE G:**

SPUR HEAD 358 (NO PORTING)

### **ENGINE PACKAGE H:**

TOPLESS OUTLAW RULES

### **ALL ENGINE PACKAGE:**

TRACK RESERVE THE RIGHT TO ADJUST WEIGHTS IN INTEREST OF COMPETITION, SHOULD IT BE DEEMED NECESSARY

---

## **FRAMES**

1-ALL FRAMES MUST BE OF STEEL CONSTRUCTION

2-SQUARE OR RECTANGULAR FRAMES MUST HAVE A MINIMUM OF 2" BY 2" MATERIAL WITH .083 WALL THICKNESS

3-IF ROUND TUBE FRAME, TUBING MUST HAVE A MINIMUM OF 1 ¾" OUTSIDE DIAMETER WITH .083 WALL THICKNESS

## **WHEELBASE**

1-MINIMUM WHEELBASE WILL BE 103" WITH 1" TOLERANCE

## **ROLLCAGE**

1-ALL CARS MUST HAVE A SUITABLE STEEL ROLL CAGE PROTECTING THE DRIVERS COMPARTMENT, INCLUDING HEADREST

2-SIDE ROLL BARS ARE MANDATORY, AND MUST EXTEND INTO DOOR PANELS, A MINIMUM (3) BARS MUST BE USED ON LEFT SIDE

3-EACH BAR MUST BE AT LEAST 1" IN DIAMETER WITH A MINIMUM THICKNESS OF .083

4-ROLL CAGE MUST BE WELDED TO THE FRAME

**BODY:**

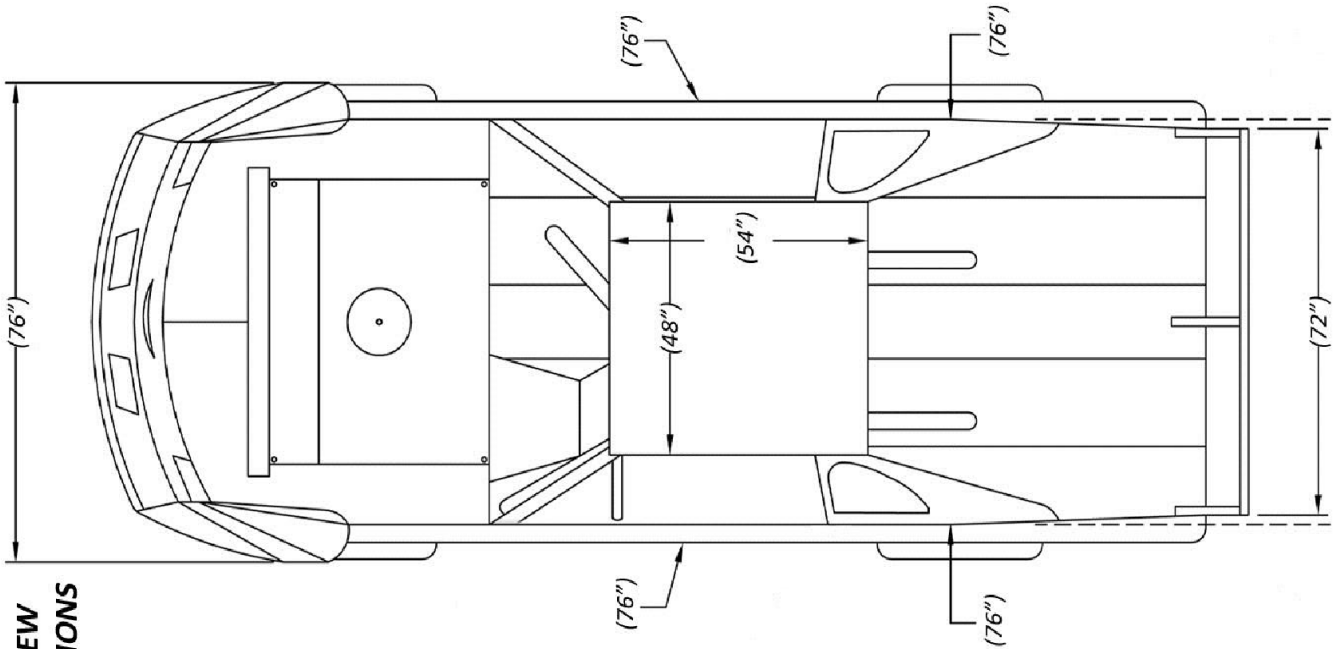

**TOP VIEW  
DIMENSIONS**

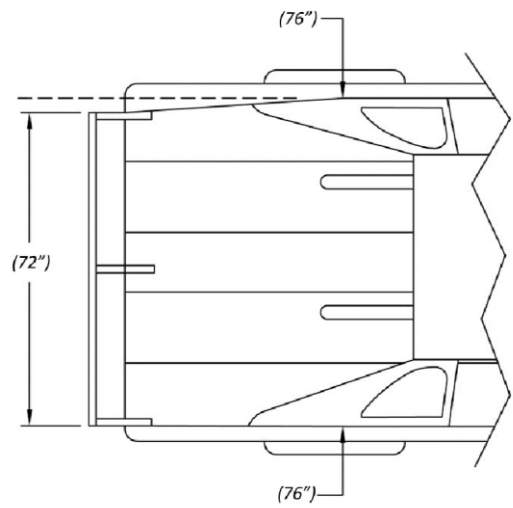
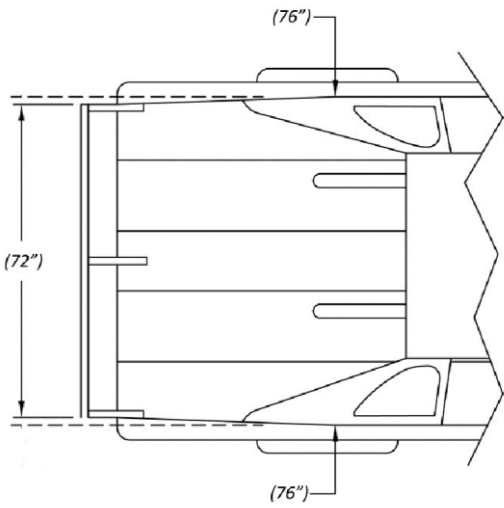

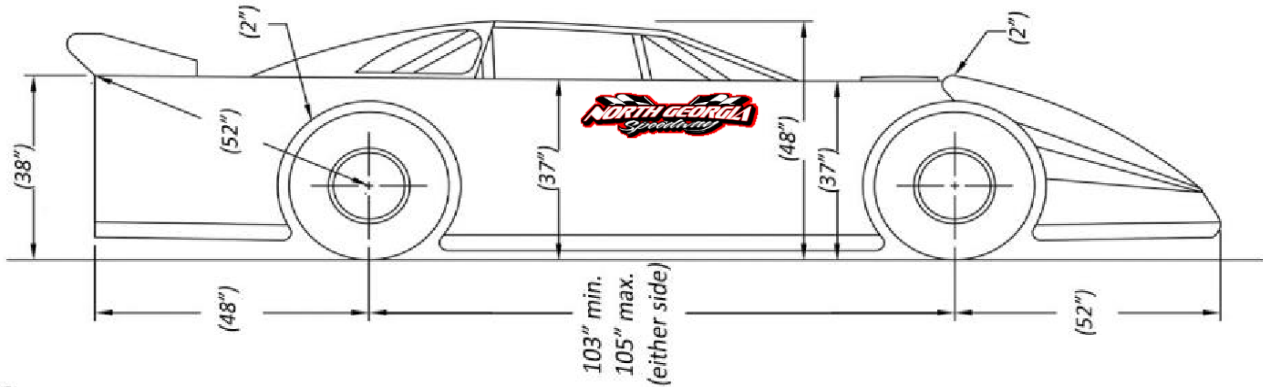

**SIDE VIEW  
DIMENSIONS**

LIMITED LATE MODEL CAN BE TOPLESS . A PIECE OF ALUMINUM IS ALLOWED TO BE PLACED ON ROOF OVER THE DRIVERS HEAD , IF PREFERRED

**SAFETY:**

NGS / DIXIE/ROME SAFETY RULES APPLY IN GENERAL RULES ALSO APPLY

1-APPROVED HELMET AND FULL FIRE RESISTANT DRIVERS SUIT REQUIRED

2-ALL CARS MUST HAVE 3 INCH SEAT BELT WITH SHOULDER HARNESSSES AND MUST BE ATTACHED TO THE ROLL CAGE,  
UNLESS YOU RUN A HEAD & NECK RESTRAINT, 2" SHOULDER HARNESS IS ALLOWED

3-ALL CARS MUST HAVE AN APPROVED FIRE EXSTINGUSHER , SECURELY MOUNTED, WITHIN EASY REACH OF THE DRIVER . A HALON SYSTEM IS RECOMMENDED

**BRAKES:**

1-FOUR WHEEL DISC BRAKES ARE PERMITTED

2-NO CARBON FIBER BRAKE PARTS PERMITTED



## **FUEL CELL/FUEL**

- 1-AN APPROVED FUEL CELL (32 GAL MAXIMUM) MUST BE SECURELY MOUNTED IN THE TRUNK AREA OF THE CAR , INSIDE A .20 GAUGE METAL BOX SUPPORTED BY A MINIMUM OF 2" BY 1/8" STEEL STRAPS
- 2-ALL FUEL CELLS MUST BE COMPLETELY VISIBLE FROM REAR OF THE CAR
- 3-FUEL CELL MUST NOT BE MOUNTED LOWER THAN THE BOTTOM OF THE QUICK CHANGE REAR END.
- 4-PUMP GAS OR RACING FUEL ONLY
- 5-PUMP GAS MAY CONTAIN UP TO 10% ETHONAL AS ALLOWED BY LAW
- 6-GAS MUST PASS THE ACID TEST
- 7-E85 IS ALLOWED
- 8-FUEL MUST CHECK WITHIN 1% AT ANY TIME CHECKED (MIN 84% ETHANOL-MAX 86%)
- 9-NO ALCOHOL, METHANOL , NITROUS OXIDE , OR CHEMICAL ADDITIVE INCLUDING , BUT NOT AMITE TO, PROPYLENE OXIDE , NITROMETHANE OR ANY NITRATE

## **TRANSMISSION:**

- 1-MUST HAVE AT LEAST ONE FORWARD AND REVERSE GEAR IN WORKING ORDER
- 2-NO STRAIGHT DRIVES OR IN & OUT BOXES

## **WHEELS**

- 1-ANY BRAND OR TYPE WHEEL ALLOWED, MUST BE MOUNTED WITH LUG NUTS
- 2-NO KNOCK -OFF OR CENTER LOCK WHEELS
- 3-MAXIMUM WHEEL WIDTH 14"



**WEIGHT:**

**SEE TABLE UNDER ENGINE SECTION FOR SPECS FOR WEIGHTS**

- 1-ALL CARS MUST HAVE A SPECIFIED WEIGHT POSTED ON THE TOP LEFT SIDE OF ROOF
- 2-MINIMUM WEIGHT WILL BE MEASURED WITH DRIVER IN THE CAR
- 3-ATTACHED WEIGHT MUST BE SECURELY BOLTED TO FRAME WITH ½ OR LARGER BOLTS AND PAINTED WHITE OR SILVER WITH CAR NUMBER CLEARLY PAINTED ON THEM
- 4-NO WEIGHT AMY BE ATTACHED TO REAR BUMPER
- 5-NO LEAD PELLETS OR LIQUID WEIGHT
- 6-NO DRIVER OPERATED WEIGHT ADJUSTING DEVICES
- 7-ONE POUND PER LAP WEIGHT ALLOWEANCE AFTER THE RACE
- 8- TRACK RESERVES THE RIGHT TO ADJUST WEIGHTS IN INTEREST OF COMPETITION SHOULD IT DEEM NECESSARY

**PROTEST LATE MODEL FEES**

\$400	ONE HEAD(NO VALVES WILL BE PULLED
\$300	OIL PAN
\$200	TIRE (PER TIRE)
\$100	ENGINE SETBACK (1" TOLERANCE)
\$100	FUEL/GAS

**ANY ITEM NOT LISTED IN PROTEST FEES IS CONSIDERED A VISUAL PROTEST ITEM AND MUST BE PROTESTES BEFORE RACE AND NOT AFTER**