

# UniqueTek “Tips” File #20: “Stuck Case Removers”

Rev. 2; 04/2018

By Lee Love

**Sooner or later** it happens to everyone ... a case gets stuck in the resize die. By far the most common cause is no case lubrication. But there are various other possible reasons.

- Improper case lubrication (too much, too little or a poor-quality lubricant)
- Dirty case
- Wrong size case for the die
- Wrong sizing die for the case

Regardless of the cause, if you are not prepared with a stuck case removal kit (either commercial or DIY), you will be dead in the water. And using brute force to remove the case can damage the die. A stuck case removal kit provides an easy, effective solution to the problem and most of the major die manufacturers sell one, including Redding, Hornady, Lee, RCBS and Forster.

There are three types of stuck case removal kits;

- 1) Screw
- 2) Punch
- 3) Press Mounted

**WARNING: Do not attempt to use any type of stuck case remover with cases with live primers or with loaded ammunition. Serious injury could result!**

## Screw

Most of the currently available stuck case removal kits use a screw. The primer pocket is drilled out, the hole threaded, and a screw used to jack the stuck case out of the die. Examples include:

- Hornady #050033 MSRP=\$20.79
- Lyman #7680350 MSRP=\$22.50
- RCBS #9340 MSRP=\$22.95
- Redding #22000 MSRP=\$35.30



Each of these kits contains essentially the same list of components.

- #7 Drill Bit
- 1/4"-20 Thread Tap
- 1/4"-20 Socket Head Cap Screw (1" to 1-1/2" length)
- 3/16" Long Arm Hex Wrench (not included in Hornady kit)
- Stuck Case Remover Body

The **Lyman Stuck Case Remover Kit** deserves special mention for two reasons.

### 1. The Stuck Case Remover Body:

- Threads onto the 7/8"-14 threads of the die body.
- Serves as a guide for the drill bit and thread tap ... ensuring that the hole is drilled and threaded squarely.
- Has flats on the sides to make clamping in a vice easy and secure, and prevents scratching up the die body or damaging the die threads.

The Stuck Case Remover Body of all the other kits has only a chamfer on the mouth to keep it centered the die body and functions solely as a case remover.

### 2. A Tap Holder is Included:

It includes a unique tap holder that utilizes the long arm hex wrench as a T-handle. If you don't already have a tap handle, this is a bonus.



## Instructions:

1. Remove the Expander/Decap Rod lock nut and back the rod out until the decap pin is free of the primer flash hole. Do not attempt to remove from die.
2. Place sizer die upside down in a vice. Pad the vice jaws with wood to prevent scratching the die body.  
**TIP:** Instead of a vice, install the die upside down in your press. Remove the die lock nut and install it on top of the press as this will prevent it from loosening during Steps 3 through 5.
3. Using the #7 drill bit, drill straight through the primer pocket and primer flash hole and completely through the case web. DO NOT allow the drill bit to extend past the case web as this would damage the Expander/Decapping rod.  
**NOTE:** If using a Lyman kit, the Remover Body is screwed onto the die body prior to drilling or tapping threads and serves as a guide.  
**TIP:** Attach a drill stop to the drill bit to prevent it from entering the case deeply enough to damage the Expander/Decap unit. You only need to drill through about 1/4" on most cases. I set it to 5/16" so I'm certain that I've drilled completely through the case web.
4. Using the 1/4"-20 thread tap, cut threads in the hole drilled through the case web. Tap threads completely through the hole but DO NOT allow the thread tap to extend far enough into the case that it damages the Expander/Decapping rod.  
**TIP:** Apply a few drops of oil to the thread tap to make cutting easier.  
**TIP:** Turn the tap 1 full turn clockwise then 1/2 turn counterclockwise to release brass chips. Repeat until the hole is fully tapped.
5. Place the Stuck Case Remover Body over the case head. Insert the Socket Head Cap Screw down through the hole in the Stuck Case Remover Body and engage the threads just tapped in the case head. Using the hex wrench, continue turning the Socket Head Cap Screw until the stuck case is pulled loose.  
**TIP:** Apply a drop of oil to the screw where it engages the brass.  
**TIP:** Applying penetrating oil to the outside of the case can aid removal.
6. Now that the case is free of the die, remove the Expander/Decap Unit from the case mouth.



## Expander/Decap Unit Removal

You will notice that the instructions stop short of explaining just how to remove the Expander/Decap Unit. It is highly unlikely that you will be able to simply pull it out through the case mouth with your fingers. Here is why...

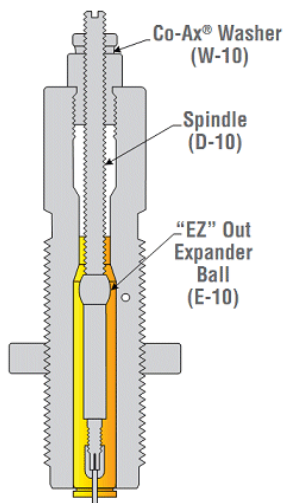

Forster Benchrest Die

Most cases become stuck when they are fully inserted into the die. At that point, the expander ball has already passed completely through the case neck and the case neck is being resized by the die (see drawing at left). The case neck is being squeezed tightly by the die making the ID of the case neck smaller ... greatly increasing the amount of force needed to pull the expander ball back through. Once the case is unstuck, the brass of the case neck springs back slightly, thus requiring less force to pull the expander bead back through the case neck. But, even then, it will not simply slide out.

If the die uses a threaded spindle (like the Forster Expander/Decap unit shown at right), it is easy to just cut off the case head and remove it from that end after removing the Spindle Lock Nut and Spindle Bushing. But some dies don't use a threaded spindle (e.g. the Redding Expander/Decap unit shown at right). In this case, the only way to remove the expander/decap rod is to pull it back through the case mouth.



Forster Redding

If there is enough of the rim remaining on the case, you can reinstall the die in the press, raise the ram and slide the shellholder into place ... simultanelusly engaging the ram and the remains of the case rim. Rotate the shellholder (or the case) to a position where it gets the most grip of the remaining rim. Then lower the ram slowly to pull the case off the Expander/Decap assembly. Of course this only works on single stage presses. If you have a progressive press, you'll need another solution.

Another way of removing the Expander/Decap assembly is to clamp the base of the case in a vice, grasp the Expander/Decap assembly with pliers, then tap the pliers with a hammer. Admittedly, this is a less than graceful procedure and the possibility of damaging the Expander/Decap assembly is high. I wish there was something like a slide hammer designed specifically for this job. I have seen some kits to convert a pair of locking jaw pliers (e.g. Vice Grip) into a slide hammer, but they are expensive.

NOTE: The Forster Stuck Case Removal Kit (described in the next section), is specially designed to remove spindle type Expander/Decap units prior to removing the stuck case (see details in the next section).

Regardless of which remover is used, damaging parts of the Expander/Decap assembly is possible. In particular, the dacap pin, expander bead and collet. But it is also possible to bend the rod or damage the threads of spindle type assemblies. Therefore, it is a good idea to keep spare parts on hand to rebuild it ... or replace it entirely.

## Punch

Punch type kits use a solid rod to punch out the stuck case from inside and include a special hex nut to extract the decap rod. I was able to find only two kits of this type on the market.



- Forster #SC1000 MSRP=\$28.00
- RCBS #9355 MSRP=\$9.45

Both kits contain essentially the same list of components.

- Hex Nut - Small (#10-32 thread)
- Hex Nut - Large (1/4"-28 thread)
- Protective Washer (not included in RCBS kit)
- Removal Rod - Small (3/16" dia.)
- Removal Rod - Large (1/4" dia.)

The Forster kit is described as being designed to work with “any sizing die with threaded spindles except Lee Collet Dies”. Indeed, if you do use resize dies of this type, then this type of stuck case remover kit is preferable to the “Screw” type remover kits described earlier.

### Instructions:

1. Unscrew the Spindle Locknut, Co-Ax<sup>®</sup> Washer and Spindle Bushing from the Decapping/Expander Assembly and set aside.  
Note: The Spindle Bushing may be difficult to unscrew depending on where the Expander Ball is located inside the stuck case. Using a screwdriver, loosen the Spindle clockwise for a complete turn, which will lower the Expander Ball. Repeat several times as needed.
2. Place sizing die in a vice. Pad the vice jaws with wood to prevent scratching the die body.  
**TIP:** Instead of a vice, install the die in your press.
3. Place the Protective Washer on top of the die body.  
NOTE: The Protective Washer acts as a bearing between the top of the die and the bottom of the Hex Nut and serves to protect the top of the die from being scratched up.  
**TIP:** If you have an RCBS kit, just add a 5/16" flat washer from the hardware store.
4. Select the correct Hex Nut for the sizing die.  
Forster Sizing Dies: Use Hex Nut - Small (#10-32 thread)  
Other Sizing Dies: Calibers .22 to .25 - Use Hex Nut - Small (#10-32 thread)  
Calibers 6.5mm to .50 - Use Hex Nut - Large (1/4"-28 thread)
5. Place a drop of oil on the Hex Nut threads.  
NOTE: Lubrication is critical as there will be a LOT of force on the threads while pulling the Expander Ball back through the case neck.
6. Using your fingers, screw the Hex Nut onto the Spindle until it contacts the Die Body.
7. Using a screwdriver to hold the top of the spindle from turning, use a wrench to turn the Hex Nut, raising the spindle. Continue until the spindle comes free of the sizing die.
8. Remove the Hex Nut from the spindle and set aside.
9. Select the correct Removal Rod size for the sizing die.
10. With the rounded end down, insert the Removal Rod into the sizing die until it makes contact with the web of the stuck case.
11. Using a hammer, sharply strike the flat end of the Removal Rod. The stuck case will fall out the bottom of the die.

It should be noted that these kits remove the Expander/Decap assembly while the case neck (indeed the entire case) is still being squeezed by the die. So the force required to pull the expander bead back through the case neck will be very high ... much higher than if the case neck is first disengaged from the die. Therefore it is more likely that you will damage some part of the Expander/Decap assembly.

## Press Mounted Kits

There are only two products currently in this category. Both use the power of your single-stage press to pull the stuck case from the die. But they go about it in slightly different ways.

### Frankford Arsenal

Frankford Arsenal announced their new stuck case remover back in the fall of 2017 ... but it has yet to appear on the Forster web site. So I don't have an official MSRP. It appears on Midway USA as "Coming Soon" (estimated in stock 05/26/18) and just "Out of Stock" on others (e.g. Midsouth Shooters, Natchez and Precision Reloading). Since I first saw it back in January 2018 the "estimated in stock" date has been pushed out several times.

- Frankford Arsenal Platinum Series Stuck Case Remover  
#1078192 MSRP = \$29.99

The kit contains only two components.

- Long Arm Hex Wrench
- Remover Clamp (my name, not Frankford Arsenal's name)



The Frankford Arsenal kit description says it "provides optimal leverage with use of reloading press. There is no need to remove or adjust the sizing die and there are no extra tools required". The Remover Clamp attaches to the ram just like a shellholder and is essentially a miniature vice that grips the base of the stuck cartridge case. The down stroke of the ram pulls the stuck case from the die. I was unable to get a copy of the user instructions or a sample unit for T&E, so the instructions are based on my best educated guess.



#### Instructions:

1. Lower press ram and remove shellholder.
2. Install Remover Clamp on ram.  
Note: Can be installed only on a single-stage press.
3. Open jaws of Remover Clamp wide enough so that there is plenty of room for the case head.
4. Raise the ram until the case head is between the jaws of Remover Clamp.
5. With the ram still up, tighten the jaws of Remover Clamp until it has a firm grip on the case head.
6. Lower the press ram. This will remove the stuck case completely from the die.

That's all there is to it. You don't need to remove the die from the press and you don't need to back out the Expander/Decap unit as there is enough space provided within the Remover Clamp to accommodate the decap pin. And it solves the problem of how to get the unstuck case off the Expander/Decap unit.

However, I would caution against simply resuming resizing brass without first cleaning, inspecting, and lubing the die! And I'd recommend removing the die from the press to facilitate that process ... especially the inspection part. After all, a full length resize die is the least complicated die to set up ... on either a single-stage or progressive press ... so removing it is no big deal. In the end, the Frankford Arsenal kit doesn't fully eliminate the need to remove the die from the press.

## UniqueTek, Inc.

UniqueTek just launched (on 4/18/18) a press mounted stuck case remover kit. It is a “hybrid” approach as the case primer pocket and web are drilled out and threaded (like the “screw” type kits) but then the actual case removal is done on the press (like the new Frankford Arsenal kit).

- UniqueTek Stuck Case Remover  
Item No.: T1663      MSRP = \$27.95

The kit contains the following components.

- #7 Drill Bit
- 1/4"-20 Thread Tap
- Stuck Case Remover Assembly

The Stuck Case Remover assembly is installed on the press ram ... just like a shellholder. But instead of grasping the rim, it threads into the case web.



### Instructions:

1. Remove Die from press and clamp in a vice.
2. Back out the Expander/Decap Rod as far as possible.
3. Drill through the primer pocket and case web then thread the hole 1/4"-20.
4. Reinstall Die into press.
5. Install the Stuck Case Remover Assembly on the press ram as if it were a shellholder.  
Note: Can be installed only on a single-stage press.
6. Raise the ram gently until the tip of the 1/4"-20 screw contacts the case, then turn the thumb nut (the black knurled disk) to engage the threads cut into the case web. Continue until the screw is fully engage and the thumb nut contacts the base of the case.
7. Lower the press ram. This will remove the stuck case completely from the die.

Note: The instructions that come with the kit are much more detailed than this but are abbreviated here for brevity.

That's all there is to it. And it solves the problem of how to get the unstuck case off the Expander/Decap unit. You still need to remove the die from the press to drill and thread the case web, but you then get to use the mechanical advantage of your press to smoothly remove the case from the die body and from the Expander/Decap assembly.

## The DIY Approach

If you didn't plan ahead for the possibility of a stuck case ... or just prefer the DIY approach to things ... you can always try to pull together the individual parts.

### DIY Screw Type

Building your own screw type stuck case remover is quite easy. Most of the items you need are relatively inexpensive and easy to find at hardware or home improvement stores.

You'll need these components.

- #7 Drill Bit (about \$3.00) <sup>1</sup>
- 1/4"-20 Thread Tap (about \$5.00) <sup>2</sup>
- 1/4"-20 x 1" to 1-1/2" Socket Head Cap Screw
- 3/16" Long Arm Hex Wrench (about \$2.00) <sup>3</sup>
- Stuck Case Remover Body

1. You can substitute a 13/64" drill bit but don't use a 7/32" drill bit as the larger hole will reduce the thread depth too much, making for weaker threads in the brass.
2. The thread tap should be a "Plug" tap, not a "Taper" tap. The length of the taper (aka chamfer) is much shorter on a Plug tap (just 3 to 5 threads) compared to a Taper tap (7 to 10 threads). So a Taper tap will extend further into the case and potentially damage the Expander/Decap assembly.
3. You can substitute a hex head bolt for the Socket Head Cap Screw ... in which case you will not need the Long Arm Hex Wrench.

The stuck case remover body can be made from any number of items you may have around. A 1/2" or 13mm socket, 1" length of copper pipe or solder coupling fitting. Add a 1/4" fender washer to cap off the end and hold the Socket Head Cap Screw. The length of the Socket Head Cap Screw will depend on the length of your Stuck Case Remover Body. You want the screw to be long enough to just pass through the web of the case but no further.

**TIP:** Here is my favorite way of fabricating a DIY Stuck Case Remover Body.

Parts:

- 1/2" Copper Tube Cap (\$0.72)
- 1/2" Copper Coupling without Stop [aka Slip Coupling] (\$0.86)  
NOTE: It is critical that you get a "slip" coupling
- Rigid Copper Pipe; about 3 inches long (2' Stub @ \$3.91)
- 1/4"-20 x 1-3/4" to 2" Socket Head Cap Screw

Drill a 1/4" hole in the center of the Tube Cap. Place the Tube Cap on the end of the Pipe then slide the Coupling over the Pipe until it is butted up against the Tube Cap. Mark where the copper pipe is flush with the end of the Coupling. Disassemble and cut off pipe where marked. Cut as squarely as possible. A pipe cutter is recommended but a hacksaw will get it done. Clean up cut end with sandpaper to remove any burrs. Reassemble parts and secure with superglue. The photo at right shows the parts after the rigid copper pipe has been cut to length but before final assembly.

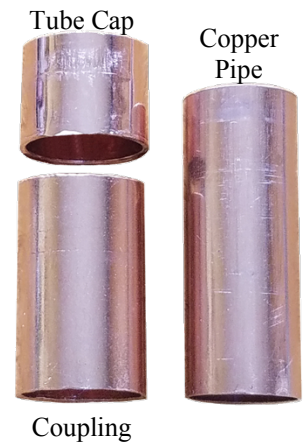

You don't need to go to the trouble of soldering the parts together. Super glue works just fine and is really just to keep the parts from slipping apart. And it only cost a few dollars, a few minutes of time, and only a few basic tools are needed.

## DIY Punch Type

Building your own punch type stuck case remover would seem to be easy. But it is not as easy as it appears. Although the “Removal Rods” are quite easy to make from any 3/16" dia. and 1/4" dia. steel, brass or aluminum rod stock, and the Protective Washer is a “no brainer”, the “Hex Nuts” are much more complicated than they appear.

You'll need these components.

- Hex Nut - Small (#10-32 thread)
- Hex Nut - Large (1/4-28 thread)
- Removal Rod - Small (3/16" dia.)
- Removal Rod - Large (1/4" dia.)
- Protective Washer

The “Hex Nuts” are highly specialized components. As you can see in the diagram at right, the “Hex Nut” is much longer than a standard hex nut, is counterbored more than half way through, and the outer diameter is much larger than normal for either #10-32 or 1/4-20 hex nuts. Approximating this part with common off-the-shelf hardware is a challenge. I tried several approaches but the end result cost more than price of either the Forster or RCBS kits.

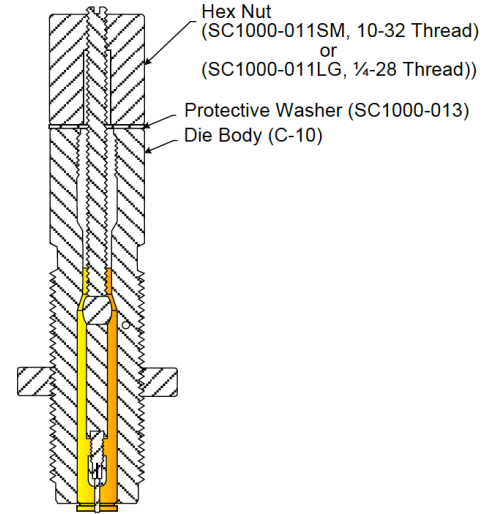

## DIY Press Mounted Type

Building your own Press Mounted type stuck case remover is simply not a DIY project. If you happen to have the machine tools and experience, you certainly could duplicate either of the kits shown here, but it would end up costing many times the kit price in materials and time.

## The “Don’t” DIY Approach

Some die manufacturers offer a stuck case removal service. You ship the die back and they'll remove the stuck case for you ... for a price. For example, Redding Reloading offers stuck case removal service for \$30.00. The service includes:

- Stuck Case Removal
- Dimensionally Inspect Die
- Re-polish Die
- Ultrasonically Clean Die
- Return Die to you postage paid with a Stuck Case Removal Kit and sample of Imperial Sizing Die Wax.

Check with the manufacturer of your die to see if they have a stuck die removal service. The big disadvantage is that you'll be without the die for more than a week.



## The Case is Unstuck ... What Next?

As I mentioned earlier, I caution against simply resuming resizing brass without first cleaning, inspecting, and lubing the die. Removing the die from the press will facilitate that process ... especially the inspection part. After all, a full length resize die is the least complicated die to set up ... on either a single-stage or progressive press ... so removing it is no big deal.

### Disassembly

Removing the die from the press and disassemble into component parts. That includes removing the expander bead and decap pin from the rod.

### Cleaning

Thoroughly clean all the parts. If you happen to have an ultrasonic cleaner, by all means use it.

### Inspection

Disassemble the die and carefully inspect all the parts. Use a magnifying lens or jewelers loupe and look for scratches, chips or brass residue in the die body and/or expander bead. Inspect the threaded parts of the expander/decap rod for thread damage and the rod itself to ensure it is not bent. Once reassembled, check that the decap pin is precisely centered in the mouth of the die.

### Assembly & Lubrication

Lightly lubricate the parts before assembly. The same case lube you normally use will be fine ... assuming it is a quality high-pressure rated case lube. I prefer to use Redding's Imperial Sizing Die Wax as it is less messy than some other lubes. Use a foam swab to reach all areas inside the die.

**TIP:** Lubricating the die is critical as it ensures that every bit of the die surface is lubed and doesn't depend on the first resized case to carry lube into the die.

**TIP:** Using a foam swab (instead of a cotton swab) ensures that you won't accidentally leave behind any fuzz ... and it can be reused many times.

## How to Not Stick a Case in the First Place!

It is far better to prevent a stuck case than to remove one. Here are a few tips that can help.

- **Use a Specialty Case Lube:** Always use a lube designed specifically as a case lube. Don't waste time on "home brew" case lubes.
- **Clean New Dies:** The preservative oil that comes on new dies is not intended to be a case lube. New dies should be thoroughly cleaned prior to use.
- **Lube the Die:** After cleaning a die, apply case lube directly to the inside of the die. This will assure that even the first case sized is adequately lubed. All that is needed is a light coating.  
**TIP:** I prefer using a foam swab as it will not leave lint like a cotton swab can. By using a swab it is also less likely that I'll apply too much lube.
- **No Dry Film Lubers!** Never use graphite, moly, mica or any other dry lube. These are adequate for case neck sizing only but are simply not up to the pressures of full length case sizing.
- **Always Clean Brass Before Sizing:** There is usually much more than just tarnish on brass cases. Any grime or grit on the brass can act as a wedge and promote case sticking. Also, dirt and grit from the ground can be highly abrasive and can damage dies.

**TIP:** Read UniqueTek Tips File #8: "Cartridge Case Lubrication" for more detailed information on case lubes.

## Final Thoughts

As you can see, there are many options for Stuck Case Remover Kits, and they'll all get the job done ... including the DIY kits. But, regardless of which type kit you feel meets your needs and budget, the most important thing is to have one on your bench before you need it! But the kit isn't the only thing you need to plan ahead. You should also keep spare parts for your Expander/Decap assembly ... and perhaps even an entire spare assembly.

NOTE: All prices shown are MSRP as of 12/31/17 and may change at any time.

### Acknowledgements:

Special thanks for Lyman for providing a sample of their Stuck Case Remover Kit and photo of the tap handle.

### Trademarks:

Every effort has been made toward giving proper credit to manufacturer's trademarks. If any were missed or incorrectly credited, it is strictly accidental.

Hornady is a registered trademark of Hornady Manufacturing.

RCBS is a registered trademark of RCBS.

### Photographs:

All photographs and drawings are courtesy of their respective manufacturers.

Disclaimer: UniqueTek, Inc. is not liable for damages or personal injury that may be incurred as a result of using the information contained in this document. Failure to follow manufacturer's recommendations may void warranties and/or result in potentially hazardous situations. Never use reloading equipment for a purpose for which it was not designed. Never use reloading equipment that has been improperly maintained or operated. It is your responsibility to ensure that your reloading equipment is properly assembled, is maintained in proper working condition, and is used according to the manufacturer's instructions and safe reloading practices.