

Brass Primer Magazine Tube Ends For Dillon RL 550 & XL 750 Presses

(Item #T1739-SL — 1 Small Primer & 1 Large Primer)

Installation Instructions

CAUTION: Make sure all primers have been removed from the Primer Magazine Tubes before proceeding.

NOTE: Refer to the Instruction Manual for your press to find the location of parts referenced below.

- 1) Remove the plastic Flexible Orifice (#14003 Large and #14024 Small) from the bottom ends of the Primer Magazine Tubes (#22031 Large and #22030 Small).

NOTE: It is recommended that one tube be done at time so that the brass tips are not accidentally installed on the wrong Primer Magazine Tubes. This is quite easy to do as the tubes are the same outside diameter.

- 2) The Brass Primer Magazine Tube Ends should be a firm press fit and not require any adhesive.

NOTE: There is a lot of variability in the outside diameters of the Primer Magazine Tubes. If the fit is too loose, a drop of Loctite 222 (Purple) Low Strength Threadlocker can be applied to ensure secure attachment. If the fit is too tight, a very light sanding of the OD of the Primer Magazine Tube with 500 grit sandpaper will help.

UniqueTek, Inc.
Gilbert, AZ

Phone: 480-507-0866

web: www.uniquetek.com
e-mail: info@uniquetek.com

✓ Tested and confirmed to work on RL 550, XL 750 and RL 1100 presses.

? According to customer feedback, they also work on the Square Deal 'B', RL 1050 or Super 1050. Minor Adjustment may be necessary.

✗ Will NOT fit XL 650 press as the tips on those Primer Magazine Tubes are a bit shorter and larger diameter.

Brass Primer Magazine Tube Ends For Dillon RL 550 & XL 750 Presses

(Item #T1739-SL — 1 Small Primer & 1 Large Primer)

Installation Instructions

CAUTION: Make sure all primers have been removed from the Primer Magazine Tubes before proceeding.

NOTE: Refer to the Instruction Manual for your press to find the location of parts referenced below.

- 1) Remove the plastic Flexible Orifice (#14003 Large and #14024 Small) from the bottom ends of the Primer Magazine Tubes (#22031 Large and #22030 Small).

NOTE: It is recommended that one tube be done at time so that the brass tips are not accidentally installed on the wrong Primer Magazine Tubes. This is quite easy to do as the tubes are the same outside diameter.

- 2) The Brass Primer Magazine Tube Ends should be a firm press fit and not require any adhesive.

NOTE: There is a lot of variability in the outside diameters of the Primer Magazine Tubes. If the fit is too loose, a drop of Loctite 222 (Purple) Low Strength Threadlocker can be applied to ensure secure attachment. If the fit is too tight, a very light sanding of the OD of the Primer Magazine Tube with 500 grit sandpaper will help.

UniqueTek, Inc.
Gilbert, AZ

Phone: 480-507-0866

web: www.uniquetek.com
e-mail: info@uniquetek.com

✓ Tested and confirmed to work on RL 550, XL 750 and RL 1100 presses.

? According to customer feedback, they also work on the Square Deal 'B', RL 1050 or Super 1050. Minor Adjustment may be necessary.

✗ Will NOT fit XL 650 press as the tips on those Primer Magazine Tubes are a bit shorter and larger diameter.

NOTE: When installing the Brass Primer Magazine Tube ends on RL 550 or XL 750 Presses, it may be necessary to adjust the height of the Primer Seating Cup for proper function. The Primer Seating Cup height specifications are shown below.

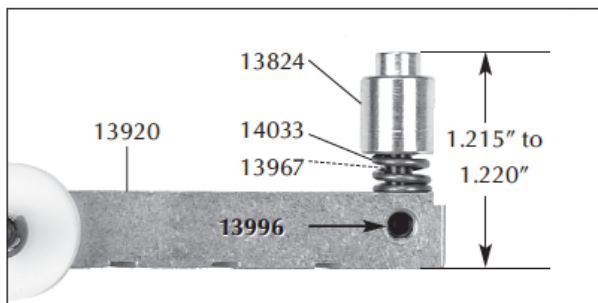

RL 550 Presses

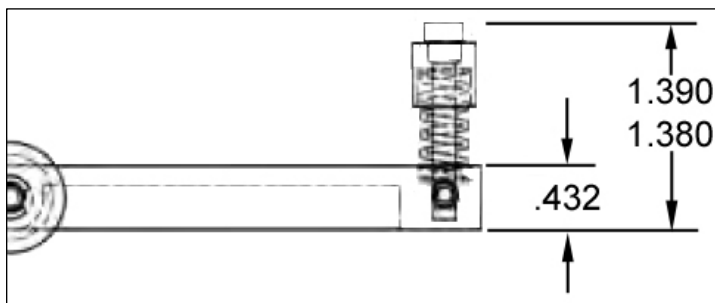

XL 750 Press

Images courtesy of Dillon Precision.

NOTE: When installing the Brass Primer Magazine Tube ends on RL 550 or XL 750 Presses, it may be necessary to adjust the height of the Primer Seating Cup for proper function. The Primer Seating Cup height specifications are shown below.

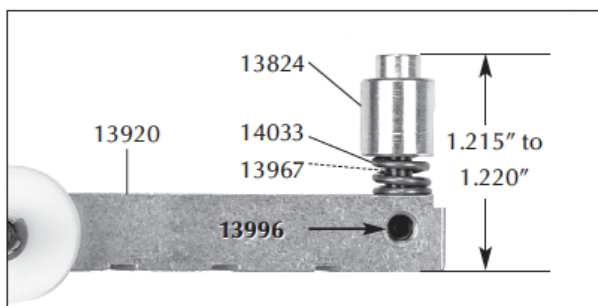

RL 550 Presses

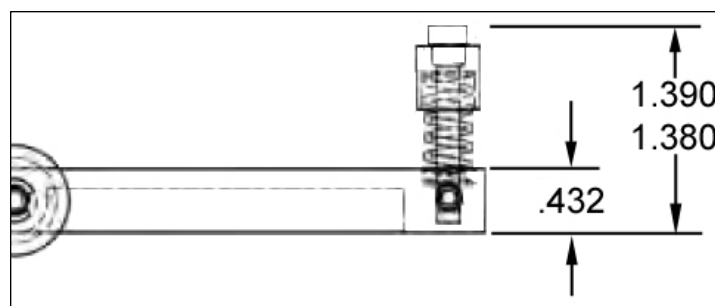

XL 750 Press

Images courtesy of Dillon Precision.