

Parts Included

Included in your package:

- Pipe Adhesive
- 1 1/2" Pipe Coupler
- Micro-Adjustability Dome
- Receiver Tray
- Grid Plate
- Pan Head Metric Screw*
4mm X 10 mm (Qty 4)
4mm X 20 mm (Qty 4)
- #10 SAE Flat Washer (Qty 4)
- Screw Lock
- 3/8" Spacer (Qty 4)
- Flex Foot (Qty 4)
- NOTE: Is only included in the Universal Loc II
- Adjustment Knobs
- Thread Lock

**Loc II
Projector Mount**

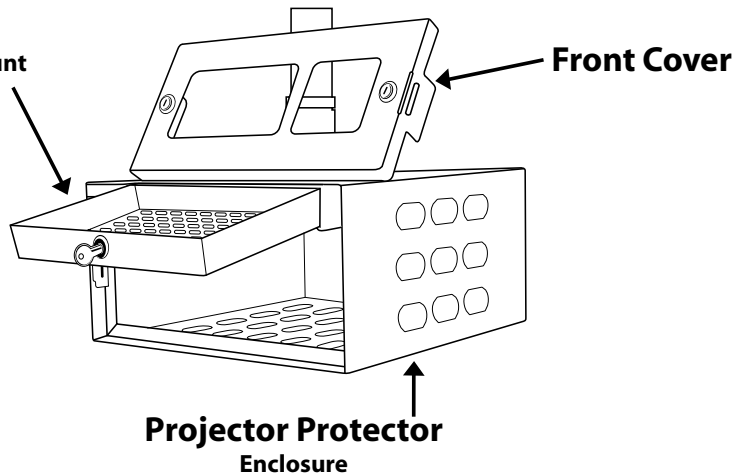

Important Warnings and Cautions

- Warning** - Failure to read, understand and follow instructions can result in serious injury, damage to equipment or voiding equipment warranty.
- Warning** - Improper installation can result in serious personal injury or death. Ensure that the mounting surface can support a weight factor of four times the combined total weight of the equipment and the mount. If not, reinforcement of the mounting surface will be necessary before installing the mount.
- Warning** - It is the installer's responsibility to make sure that the mounting surface and the subsurface is free and clear of all electrical wires, plumbing and gas pipes. Failure to provide adequate clearance of all electrical wires and pipes can result in serious personal injury or death.
- Warning** - Mount and equipment exceeding a combined weight of 150 lbs can result in damage to the support structure, the mount, the equipment and may cause personal injury.
- Warning** - Business Machine Security, Inc. does not warrant its mounts against damage caused by the end use of its mounts for any purpose other than for the purpose for which it has been designed.
- Warning** - Business Machine Security, Inc. is not responsible for damage, or injury that may result in the use of any unauthorized modifications or attachment.
- Warning** - Proper safety gear (Goggles, Glasses & Gloves) and practices should be adhered to at all times throughout the installation process.
- Warning** - Do not install the mount near any heat source or air conditioning vent which may be prone to vibration.
- Warning** - Maximum load capacity 150 lbs.
- Warning** - Do not expose to extreme temperatures.

Installation Guide

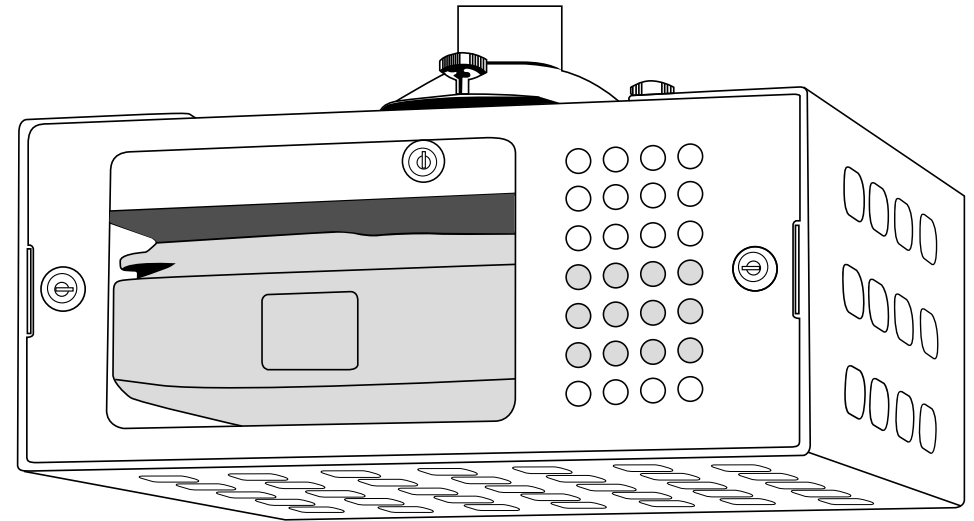

Made in USA

www.LocDown.com
www.Anchorpad.com

800.872.9562

1 Securing Receiver Protector to Pipe

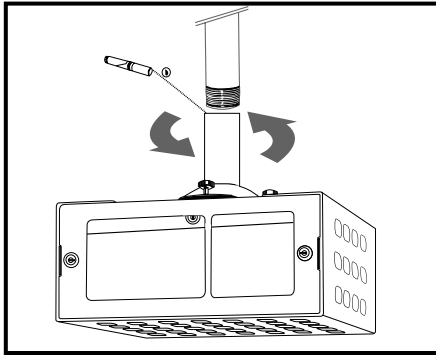

1. Apply the pipe adhesive to the inside of the coupler at the top for approximately 3 threads down.
2. Screw the coupler clockwise with the Receiver Tray onto the preinstalled 1 1/2" standard pipe threads.

2 Remove Doors & Grid Plate

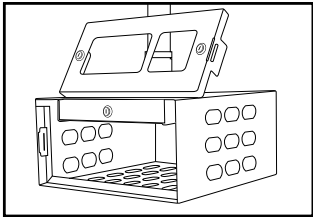

Step 1 : Unlock Front

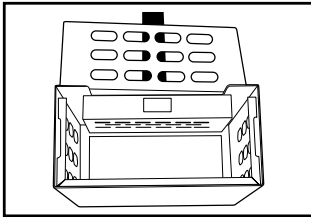

Step 1 : Unlock Rear

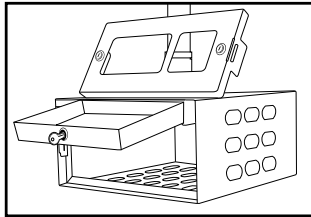

Step 2 : Unlock Grid Plate

1. After Coupler is screwed onto to Pipe. Unlock and Remove both Front and Rear Doors from Housing.

2. After Unlock Drawer that holds Grid Plate and slide plate out.

3 Mounting Projector to Grid Plate

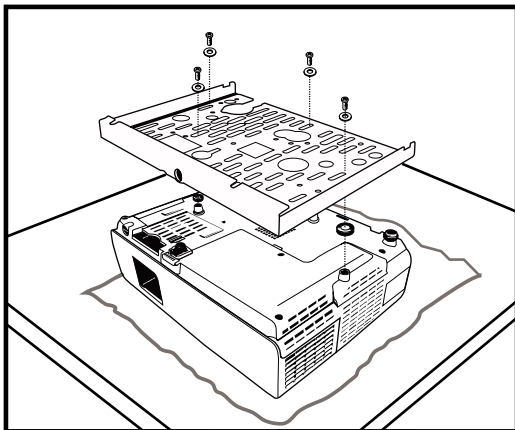

1. Place the projector upside down on a soft cloth.
2. Place the Grid Plate on the projector and line up the holes to match the projector mounting inserts.
3. Attach the mount to the projector with the supplied screws and washers, if necessary use the spacers to make each connecting point even.

4 Locking Grid Plate to Receiver Tray

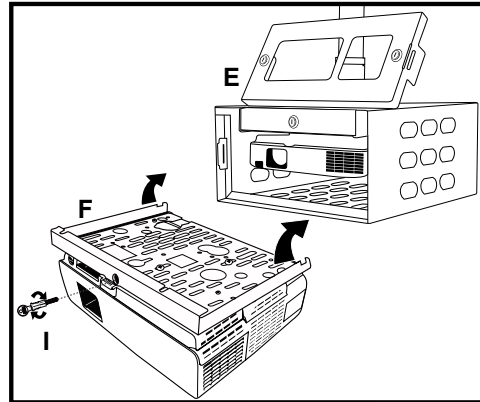

1. After the Receiver Tray (E) has been attached to the pipe, and the projector has been attached to the Grid Plate (F), slide the Grid Plate 3" into the Receiver Tray .

2. Organize the cords (see Step 4) then slide the Grid Plate completely input the Tray.

3. Insert the Screw Lock (I) into the Grid Plate (F) and turn clockwise until snug.

5 Consolidating Cords When Closing

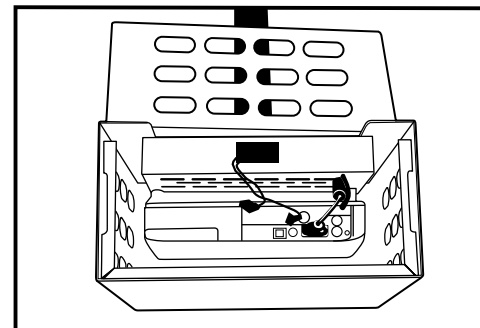

1. Before completely closing the mount, route the cables from the Pipe (A) out the cord slot (N) of the Receiver Tray (E).

2. Slide the Grid Plate (F) in while guiding the cables into the cord slot in the back of the Grid Plate.

6 Adjusting Mount

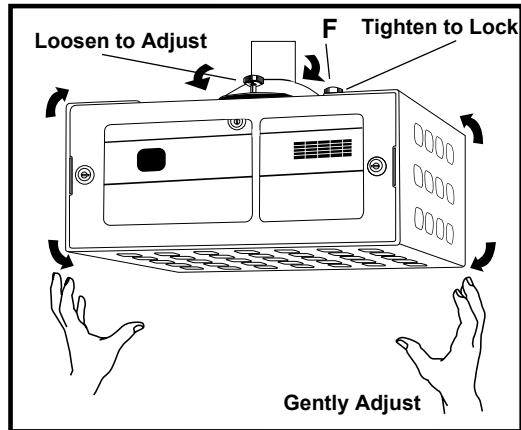

1. To align the projector, simply grab a hold of either side of the mount and adjust it up or down until you have the proper registration.

2. Tighten the 3 adjustment knobs (F) by rotating each clockwise until the mount is stiff and secure.