



Eco Water Solutions

2024 Version 5

Gorilla Pump Stations

Pump Station

Catalogue



GORILLA PUMP STATIONS

Further and Faster

PO Box 18 Foxton Beach

021 745 335

www.gorillapumpstations.co.nz

150 Litre Sewerage



150 S	Plain tank	overall size: 760L x 560w x 520h Fixed lid w- foam rubber seal 2x 110mm socket connections complete with loose blanks to customise installation
150 SP-3	750w. Non-Sanitary products. Human Waste and Toilet Tissue only	With VH100/40MF pump. <i>Human waste and toilet tissue only– no sanitary products.</i>
150 SP-6	Chops to 15mm diameter	With C50Z21.1SF pump

- Pre—piped installation
- 40mm outlet collection with mac union and ball-valve
- 50mm electrical ducting sealed outlet
- Non return valve fitted
- Pedestrian rated lid.



GORILLA PUMP STATIONS

Further and Faster

280L/340L Twin Sewer/ Greywater Pump Stations



<p>TW280</p> <p>900x650x800 Solid Removeable Lids</p>	<p>Tank & pump.</p>	<p>Non-return valve fitted</p> <p>1x 110mm rubber seal inlet</p> <p>50mm electrical outlet with ducting including cable seal.</p> <p>PVC outlet pipe -40mm</p> <p>Mac Union for easy disconnection</p> <p>Ball valve with 40mm mac union</p> <p>50mm electrical connection with seal kit to connect to 50mm electrical ducting supplied.</p> <p>50mm vent pipe connection outlet supplied</p> <p>Solid Lid</p>
<p>TW 280-3</p> <p>TW 340-3</p>	<p>750w high volume heavy duty cast iron vortex pump</p>	<p>With VH100/40MF pump. <i>Human waste and toilet tissue only– no sanitary products.</i></p>
<p>TW 280-6</p> <p>TW 340-6</p>	<p>1.1kW, heavy duty cast iron chopper pump.</p> <p>Cuts to 15mm diameter</p>	<p>With C-50Z21.1SF pump.</p> <p>Chopper Pump– Cuts down to 15mm</p>
<p>TW 280-7</p> <p>TW 340-7</p>	<p>1.5 HP heavy duty cast iron grinder pump. Cuts to 5mm diameter</p>	<p>With G40G21.75 SF pump</p> <p>Grinder Pump</p> <p>Cuts down to 5mm</p>
<p>228-LSKIT</p>	<p>High Level Alarm System</p>	<p>High level alarm box complete with float and power lead. Kit set. 12/24/230v.</p> <p>Sounds alarm at plumber’s pre-set level.</p> <p>Must be installed by a registered electrician.</p>

- Pre plumbed with 40mm Mac Union and ball valve
- Pedestrian rated lid
- 50mm vent pipe connection included
- 50mm electrical outlet sealed to ducting



GORILLA PUMP STATIONS
Further and Faster

Ecoline Range

Greywater and Sewer Pump Stations



Code	Flow Rate	
EL 65 GWSS 500w Semi Vortex Pump	20 L/m @ 4.6m 50L/m @ 4m 75 L/m @ 3m 100 L/m @ 2m 125 L/m @ 0m	450mm x 450mm x 600mm high Greywater pump station. Comes with 40mm non - return valve and mac union. Up to 100 litres per minute. 50mm inlet. With 50x40 level invert. Stainless steel semi vortex pump for grey water. 35mm soft solids.
EL 65-3 Sewer Vortex	50 L/m @ 9.4m 100 L/m @ 8.4m 150 L/m @ 7.2m 200 L/m @ 6m 250 L/m @ 4.5m	450mm x 450mm x 600mm high. HIGH VOLUME Sewer pump station. Comes with 40mm non return valve and mac union. Not for sanitary products. Human waste and toilet tissue only. Up to 35mm soft solids. Cast iron vortex high volume pump. 100mm inlet
EL 140-3 Sewer Vortex	50 L/m @ 9.4m 100 L/m @ 8.4m 150 L/m @ 7.2m 200 L/m @ 6m 250 L/m @ 4.5m	650mm x 450mm x 800mm high HIGH VOLUME Sewer pump station. Comes with 40mm non return valve and mac union. Not for sanitary products. Human waste and toilet tissue only. Up to 35mm soft solids. Cast iron vortex high volume pump. 100mm inlet.
EL 140-7 Grinder 750W	50 L/m @ 14m 100 L/m @ 12m 150 L/m @ 9m 200 L/m @ 5m	650mm x 450mm x 800mm high HIGH VOLUME Sewer pump station. Comes with 40mm non return valve and mac union. Grinder pump. Cuts down to 15mm. Cast iron high volume pump. 100mm inlet
EL 140-6 Chopper 1.5KW	100 L/m @ 14.8m 200 L/m @ 12m 300 L/m @ 9.6m 400 L/m @ 6m	1.5 HP Chopper Pump 100mm inlet Chops to 15mm.

All of the above come with the following...

40mm outlet

Pre-plumbed with transparent non-return valve

50mm electrical outlet for 50mm ducting

40mm fitted mac union

Pedestrian rated solid lid

50mm vent kit

Ecoline Range

80L Grey/Waste Water Pump Station

With Automatic Submersible Pump

EL80Grey

Designed for tiny homes and grey water disposal.



<p>TPO1376 Pump Up to 5mm Particles 350W</p>	<p>Complete With.... 25mm Pipework Mac Union for quick pump removal Non—Return Valve Removable basket to catch debris, hair and large lint. Drill inlet to suit your specifications</p>
<p>Flow Rate <i>(with 25mm outlet)</i> 75L/M @1m with 12m run</p>	
<p>Please refer to www.level.org.nz's greywater recycling guidelines for the safe use of this system</p>	<p>https://www.level.org.nz/water/wastewater/on-site-wastewater-treatment/greywater-recycling/</p>

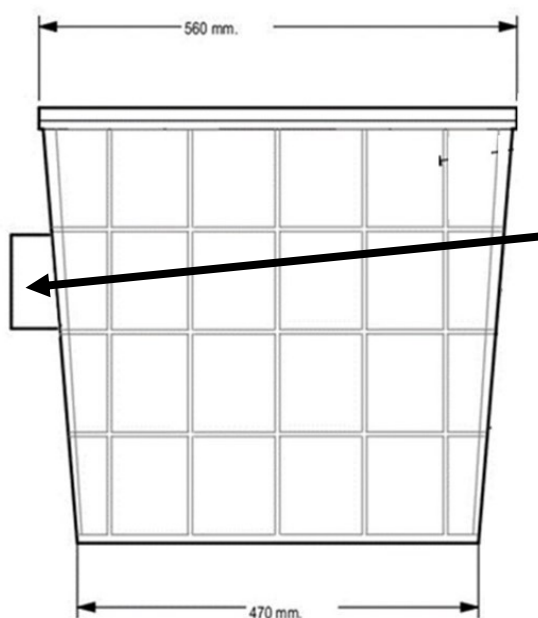

Side Elevation

110mm inlet.
Blank provided to be sealed and cut to inlet hole size to suit plumbing.

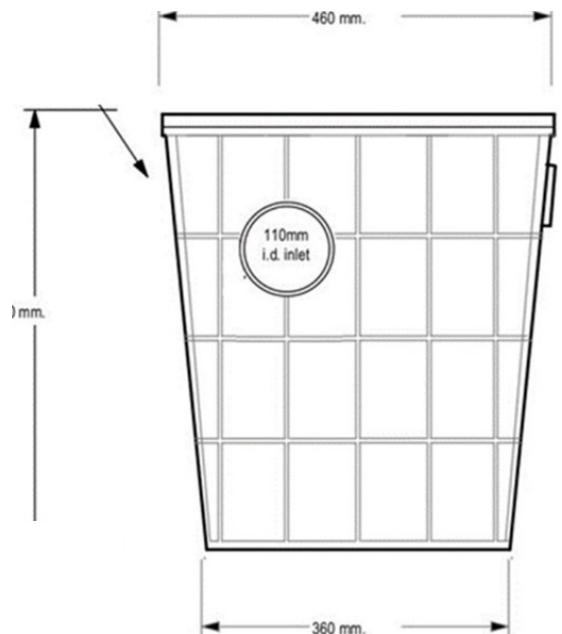

End Elevation



320 Litre- Sewerage



320 SP	Tank & pump. Conical tank, 840 max dia. X 980h Fixed lid	Non-return valve fitted 1x 110mm rubber seal inlet 50mm electrical outlet with ducting including cable seal. PVC outlet pipe -40mm Mac Union for easy disconnection Ball valve with 40mm mac union 50mm electrical connection with seal kit to connect to 50mm electrical ducting supplied. 50mm vent pipe connection outlet supplied
320 SP-3	750w. Non- Sanitary products. Human waste and toilet tissue only	With VH100/40MF pump. <i>Human waste and toilet tissue only– no sanitary products.</i>
320 SP-5	1.1kW, Grinder. Cuts to 5mm diameter	With G-40G21.1SGF pump. To be installed by a registered electrician. Separate power supply box must be encased in waterproof/ IP68 housing
320 SP-6	1.1kW, Chopper Cuts to 15mm diameter	With C-50Z21.1SF pump.
320 SP-7	1.5 HP Grinder Pump. Cuts to 5mm diameter	With G40G21.75 SF pump. Non– return valve, mac union and RCD must be fitted. Must be installed by registered tradesperson.
228-LSKIT	High Level Alarm System	High level alarm box complete with float and power lead. Kit set. 12/24/230v. Sounds alarm at plumber’s pre-set level. Must be installed by a registered electrician.
320MH	Man Hole Riser 230H (No Lid)	Man hole riser 230mm high. With lid.

- Pre plumbed with 40mm Mac Union and ball valve
- 50mm vent pipe connection included
- 50mm electrical outlet sealed to ducting
- Pedestrian rated lid
- Light weight– one person lift

500 Litre– Sewerage



Two 500L tanks plumbed together.

<p>500 SP</p>	<p>Tank & pump.</p> <p>Conical tank, 800 max dia. X 1400 H</p> <p>Fixed lid</p> <p>450mm lid diameter</p>	<p>Non-return valve fitted</p> <p>1x 110mm rubber seal inlet</p> <p>50mm electrical outlet with ducting including cable seal.</p> <p>PVC outlet pipe -40mm</p> <p>Mac Union for easy disconnection</p> <p>Ball valve with 40mm mac union</p> <p>50mm electrical connection with seal kit to connect to 50mm electrical ducting supplied.</p> <p>50mm vent pipe connection outlet supplied</p>
<p>500 SP-3</p>	<p>750w. Non-Sanitary products.</p> <p>Human waste and toilet tissue only</p>	<p>With VH100/40MF pump. <i>Human waste and toilet tissue only– no sanitary products.</i></p>
<p>500 SP-5</p>	<p>1.1kW, Grinder.</p> <p>Cuts to 5mm diameter</p>	<p>With G-40G21.1SGF pump.</p> <p>To be installed by a registered electrician. Separate power supply box must be encased in waterproof/IP68 housing</p>
<p>500 SP-6</p>	<p>1.1kW, Chopper</p> <p>Cuts to 15mm diameter</p>	<p>With C-50Z21.1SF pump.</p>
<p>500 SP-7</p>	<p>1.5 HP Grinder Pump. Cuts to 5mm diameter</p>	<p>With G40G21.75 SF pump. Non– return valve, mac union and RCD must be fitted. Must be installed by registered tradesperson.</p>
<p>228-LSKIT</p>	<p>High Level Alarm System</p>	<p>High level alarm box complete with float and power lead. Kit set. 12/24/230v. Sounds alarm at plumber’s pre-set level. Must be installed by a registered electrician.</p>

- Pre plumbed with 40mm Mac Union and ball valve
- 50mm vent pipe connection included
- 50mm electrical outlet sealed to ducting
- Pedestrian Rated Lid
- Light weight– one person lift when empty

PS1 Designed In - Ground Tanks

Our series of virgin plastic PS1 certified, in - ground tanks are perfect for heavy duty use and come in a range of sizes.

These tanks have AS/NZS 1546.1.2008 approval

1100 Litre Size <i>1330 diameter x 1190 high</i>	Complete with 40mm pipework, mac union, non-return valves, inlet and outlet seals. Non-drilled entry and exit
SP1100-3	With vortex 750w pump
SP1100-6	With 750w grinder pump
550 Litre Size <i>890 Diameter x 1080 High</i>	Complete with 40mm pipework, mac union, non-return valves, inlet and outlet seals. Non-drilled entry and exit
SP550-3	With vortex 750w pump
SP550-6	With grinder 750w pump
270 Litre Size <i>710 Diameter x 850 High</i>	Complete with 40mm pipework, mac union, non-return valves, inlet and outlet seals. Non-drilled entry and exit.
SP270-3	With vortex 750w pump
SP270-6	With grinder 750w pump
228 LSKIT	High Level Alarm. Highly recommended



SP1100



SP550



SP270



SP270 (Top View)

80- Litre Stormwater Drainage



82 DP-3	750w. Vortex	With VH100/40MF pump
----------------	-----------------	----------------------

- 40mm outlet
- Pre-plumbed with non return valve
- 50mm electrical outlet for 50mm ducting
- 2x 110mm socket blank connection loose
- 40mm mac union fitted
- Pedestrian rated lid.

150 Litre Storm Water Drainage



150 DP-3	750w. Vortex	With VH100/40MF pump
-----------------	--------------	----------------------

- 40mm outlet
- Pre-plumbed with non return valve
- 50mm electrical outlet for 50mm ducting
- 2x 110mm socket blank connection loose
- 40mm mac union fitted
- Pedestrian rated lid.



GORILLA PUMP STATIONS

Further and Faster

Storm Water Pump Stations



Code	Flow Rate	
65 DP/2 SS	20 L/m @ 4.6m	450mm x 450mm x 600mm high
	50L/m @ 4m	Stormwater pump station. Comes with 40mm non - return valve and mac union.
	75 L/m @ 3m	Up to 100 litres per minute
	100 L/m @ 2m	Stainless steel semi vortex pump for clean and dirty storm water. 35mm soft solids
	125 L/m @ 0m	
65 DP 3	50 L/m @ 9.4m	450mm x 450mm x 600mm high
	100 L/m @ 8.4m	HIGH VOLUME Stormwater pump station. Comes with 40mm non return valve and mac union.
	150 L/m @ 7.2m	
	200 L/m @ 6m	Cast iron vortex high volume stormwater
	250 L/m @ 4.5m	35mm soft solids
140 DP 2 SS	20 L/m @ 4.6m	650mm x 450mm x 800mm high
	50L/m @ 4m	Stormwater pump station. Comes with 40mm non return valve and mac union.
	75 L/m @ 3m	Up to 100 litres per minute.
	100 L/m @ 2m	Stainless steel semi vortex pump for clean and dirty storm water. 35mm soft solids
	125 L/m @ 0m	
140 DP 3	50 L/m @ 9.4m	650mm x 450mm x 800mm high
	100 L/m @ 8.4m	HIGH VOLUME Stormwater pump station. Comes with 40mm non return valve and mac union.
	150 L/m @ 7.2m	
	200 L/m @ 6m	Cast iron vortex high volume stormwater
	250 L/m @ 4.5m	35mm soft solids

All of the above come with the following...

- Vortex System.
- 40mm outlet
- Pre-Plumbed with transparent non-return valve
- 50mm electrical outlet for 50mm ducting
- 40mm mac union fitted
- Pedestrian - rated slotted FRP lid

Storm Water Sumps

65PB	Pedestrian rated pit box lid	Overall Size: 450mm Wide, 450mm Long, 600mm High. 300x300 Base Comes with slotted FRP lid.
65PB1T	One tonne rated lid.	Overall Size: 450mm Wide, 450mm Long, 600mm High. 300x300 Base Comes with slotted FRP lid.
65PBSolid	Solid Pedestrian rated pit box lid	Overall Size: 450mm Wide, 450mm Long, 600mm High. 300x300 Base
140PB	Pedestrian rated pit box lid.	Overall Size: 650mm Wide, 450mm Long, 800mm High. 500x300 Base Comes with slotted FRP lid.
140PB3T	Three tonne rated lid.	Overall Size: 650mm Wide, 450mm Long, 800mm High. 500x300 Base Comes with slotted FRP lid.
140PBSolid	Pedestrian rated solid lid	Overall Size: 650mm Wide, 450mm Long, 800mm High. 500x300 Base Comes with solid FRP lid.
170PB	Pedestrian rated grate	Comes with slotted FRP lid. 650x450x1000
170PB3T	Three tonne rated lid.	Comes with slotted FRP lid. 650x450x100
170PBSolid	Pedestrian rated solid lid	Comes with solid lid 650x450x1000

All Storm Water Sumps Are Sold Subject To Availability.

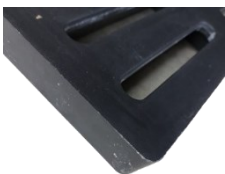

Standard Pedestrian Slotted Lid



Solid Pedestrian Lid



One Tonne Slotted Lid



Ecoline Range

Sewerage/Greywater Pump Station Auto Coupler

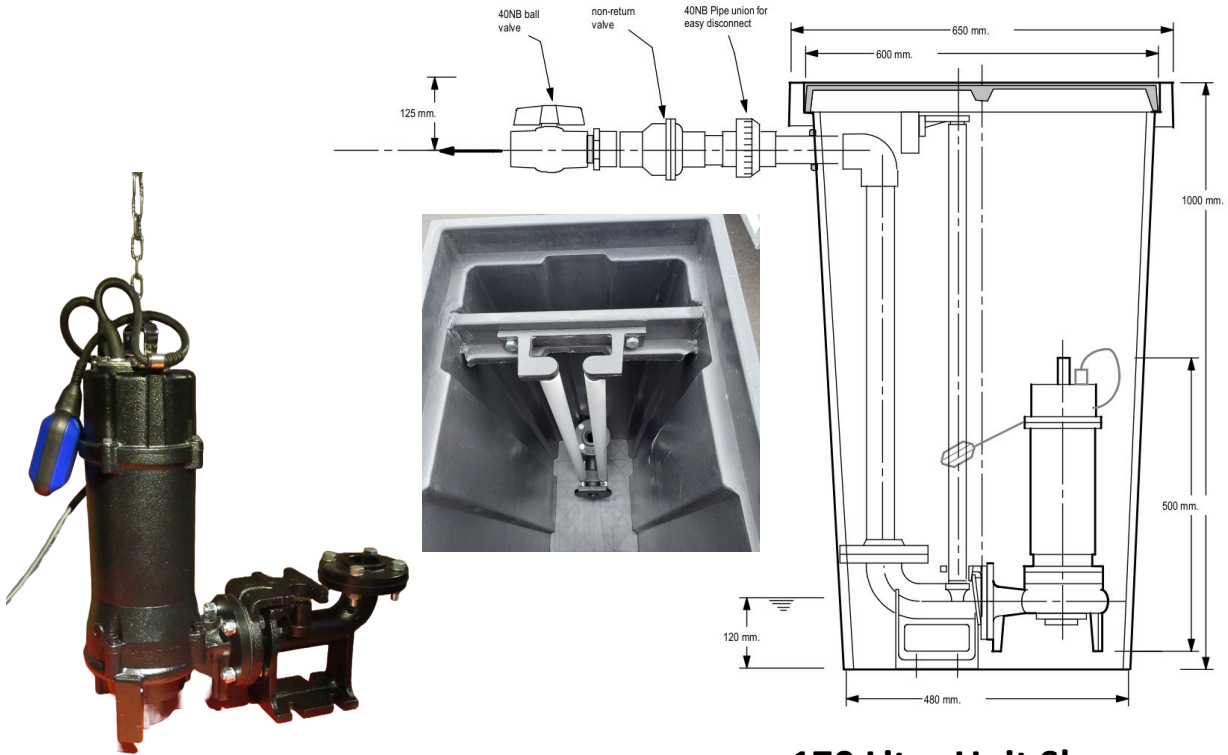

170 Litre Unit Shown

All Sizes Offer Easy Maintenance and Pump Replacement

Simply Lift the Pump out of the Chamber!

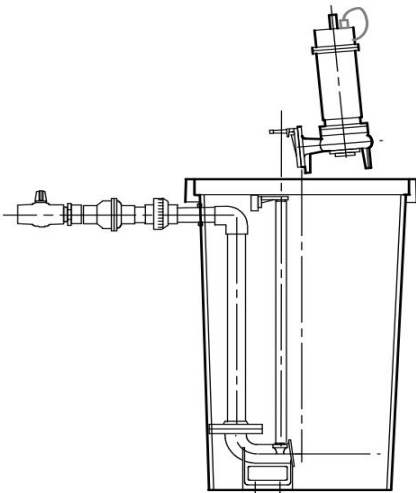

Step 1.

Slider unit is bolted on to pump outlet flange. The pump is positioned over the top of the guide rails. Discharge ball valve is off

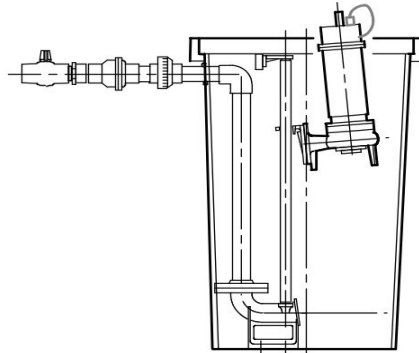

Step 2.

The slider unit fits between the guide rail pipes, and the pump and slider assembly is then carefully lowered.

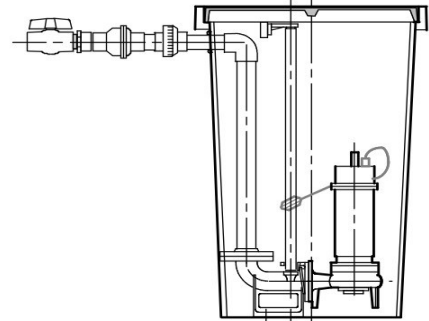

Step 3.

When lowered to the bottom, the slider locks into the discharge pipe bend assembly. The discharge ball valve is opened and the pump is ready for operation.

170ACG	Available in 140-170 Single Stations and 280-340 Twin Stations	Can be specified with the pumps listed below.
G40G21.75SF	Grinder	Cuts up to 5mm
C-50Z21.1SF	Chopper	Cuts up to 15mm

Note: Prices are for auto coupler unit only. Please refer to our catalogue for tank prices.

Submersible Pump Range & Clear Non-Return Valves



<p>TPO1376</p>	<p>Clean Stormwater Only Up to 5mm Particles 400W 40mm down to 25mm outlet adaptor</p> <p><i>Below specs are at 40mm outlet</i></p> <p>20 L/m @ 6.5m 50 L/m @ 4.5m 75 L/m @ 2.5m</p>
-----------------------	--



<p>SGW550-1</p>	<p>Suitable for Dirty Water No sanitary products 550W Impeller Type Pump Up to 32mm Soft Solids</p> <p><i>Below specs are at 40mm outlet</i></p> <p>20 L/m @ 4.6m 50 L/m @ 4m 75 L/m @ 3m 100 L/m @ 2m 125 L/m @ 0m</p>
------------------------	---



<p>VH100/40</p>	<p>Stormwater Vortex Cast Iron 1 HP Motor 32mm Soft Solids</p> <p><i>Below specs are at 40mm outlet</i></p> <p>50 L/m @ 9.4m 100 L/m @ 8.4m 150 L/m @ 7.2m 200 L/m @ 6m 250 L/m @ 4.5m</p>
------------------------	--



<p>NRVC40</p>	<p>40mm Non-Return Valve Transparent Body Full Flow 40mm Pressure Pipe Both Sides Can be disassembled if required</p>
----------------------	---



<p>3</p> 	<p>V-VH100/40MF</p> <p>32mm diameter soft solids</p> <p>Non-sanitary products</p> <p>40mm outlet. Human waste and toilet tissue only</p>	<p>vortex</p> <p>1Hp</p> <p>13.5kg</p>	<p>50 L/m @ 9.4m</p> <p>100 L/m @ 8.4m</p> <p>150 L/m @ 7.2m</p> <p>200 L/m @ 6m</p> <p>250 L/m @ 4.5m</p>
<p>5</p> 	<p>G-40G21.1SF</p> <p>cut to 5mm diameter</p> <p>To be installed by registered electrician.</p> <p>Separate power supply box must be encased in a waterproof/IP68 housing</p>	<p>Grinder</p> <p>1.5Hp</p> <p>29kg</p>	<p>50 L/m @ 15.5m</p> <p>100 L/m @ 13.5m</p> <p>150 L/m @ 11m</p> <p>200 L/m @ 7m</p>
<p>6</p> 	<p>C-50Z21.1SF</p> <p>chop to 15mm diameter</p>	<p>Chopper</p> <p>1.5Hp</p> <p>25kg</p>	<p>100 L/m @ 14.8m</p> <p>200 L/m @ 12m</p> <p>300 L/m @ 9.6m</p> <p>400 L/m @ 6m</p>
<p>7</p> 	<p>G40G21.75 SF</p> <p>Grinds to 5mm diameter</p> <p>For stormwater, greywater and sewerage</p>	<p>Grinder Pump</p> <p>1.5 HP</p>	<p>Specs at 40mm outlet</p> <p>50 L/m @ 14m</p> <p>100 L/m @ 12m</p> <p>150 L/m @ 9m</p> <p>200 L/m @ 5m</p>



GORILLA PUMP STATIONS

Further and Faster



GORILLA PUMP STATIONS

Further and Faster

www.gorillapumpstations.co.nz

TPG-100 Sewerage Grinder Pump

1 HP Pump. Cuts down to 10mm



Pump Performance

Details (at 50mm outlet)

200L/m @ 4m

150L/m @ 6.15m

100 L/m @ 8.3m

50 L/m @ 10.5m

Shutoff: 13.2m



TPG-100 Sewerage Grinder Pump

Performance Tests

Wet Wipes



Absorbent Cleaning Cloth



The TPG-100 is a 1HP grinder pump which moves 200L per minute at a four meter head, and 50L per minute at a 10.2 meter head. **Do not flush wet wipes or cleaning towels into your pump station** as it will reduce the life of the pump and void the warranty– the above images are a demonstration of the pump’s abilities. TPG-100 pumps can be specified with many of our sewerage pump stations– visit our website for more information.

www.gorillapumpstations.co.nz

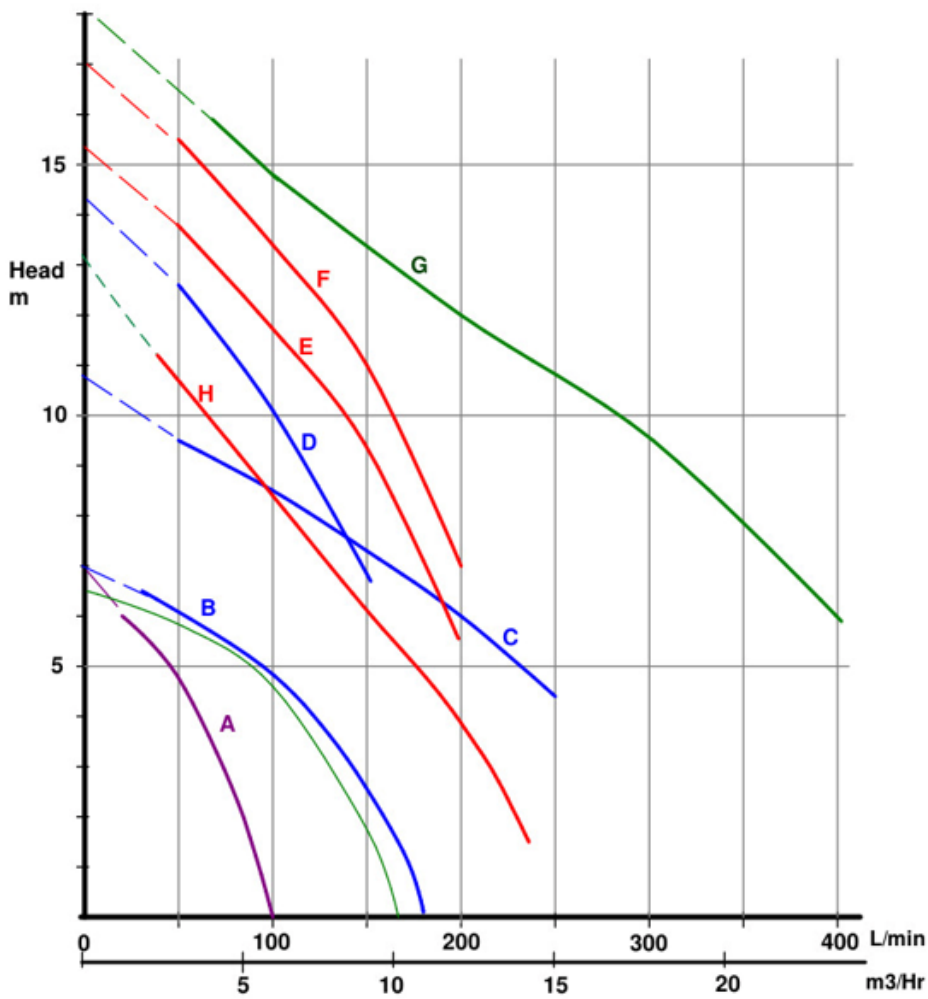

- A** TPO1376
Drainage pump, 5mm solids
350w, 25mm outlet
- B** TPO1118
vortex pump, 32mm solids
550w, 38mm outlet
- C** VH100/40MF
vortex pump, 32mm solids
750w, 38mm outlet
- D** VHG100/32MF
vortex pump, 15mm solids
750w, 32mm outlet
- E** G-40G2.75SF
Grinder Pump
750w, 38mm outlet
- F** G-40G21.1SF
Grinder Pump
1100w, 38mm outlet
- G** C-50Z21.1SF
chopper pump, chops to 15mm
1100w, 50mm outlet
- H** TPG-100
Grinder pump,
750w, 50mm outlet

CURVES05.key



GORILLA PUMP STATIONS

Further and Faster

280L/340L Twin Stormwater Pump Stations



<p>TW280 SW</p> <p>TW340SW</p>	<p>Tank & pump.</p> <p>900x650x800 Solid Removeable Lids</p> <p>900x650x1000</p>	<p>Non-return valve fitted</p> <p>1x 110mm rubber seal inlet 50mm electrical outlet with ducting including cable seal. PVC outlet pipe -40mm Mac Union for easy disconnection Ball valve with 40mm mac union 50mm electrical connection with seal kit to connect to 50mm electrical ducting supplied. 50mm vent pipe connection outlet supplied</p> <p>Slotted lid</p> <p>Fifteen tonne rated lids available.</p>
<p>TW 280-3 SW</p> <p>TW 340-3 SW</p>	<p>750w high volume heavy duty cast iron vortex pump</p>	<p>With VH100/40MF pump.</p> <p>Stormwater Vortex</p> <p>Up to 32mm Soft Solids</p>
<p>TW 280-6 SW</p> <p>TW 340-6 SW</p>	<p>1.1kW, heavy duty cast iron chopper pump</p> <p>Cuts to 15mm diameter</p>	<p>With C-50Z21.1SF pump.</p> <p>Chopper Pump– Cuts down to 15mm</p>
<p>TW 280-7 SW</p> <p>TW 340-7 SW</p>	<p>1.5 HP heavy duty cast iron grinder pump. Cuts to 5mm diameter</p>	<p>With G40G21.75 SF pump</p> <p>Grinder Pump</p> <p>Cuts down to 5mm</p>
<p>228-LSKIT</p>	<p>High Level Alarm System</p>	<p>High level alarm box complete with float and power lead. Kit set. 12/24/230v. Sounds alarm at plumber's pre-set level. Must be installed by a registered electrician.</p>

- Pre plumbed with 40mm Mac Union and ball valve
- 50mm vent pipe connection included
- 50mm electrical outlet sealed to ducting
- Pedestrian rated lid (fifteen tonne lids available for some pump stations).



GORILLA PUMP STATIONS
Further and Faster

Water Trap 24L

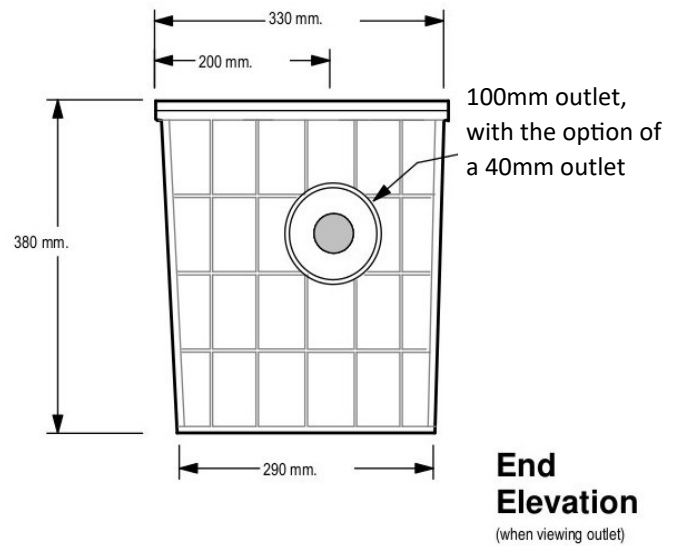
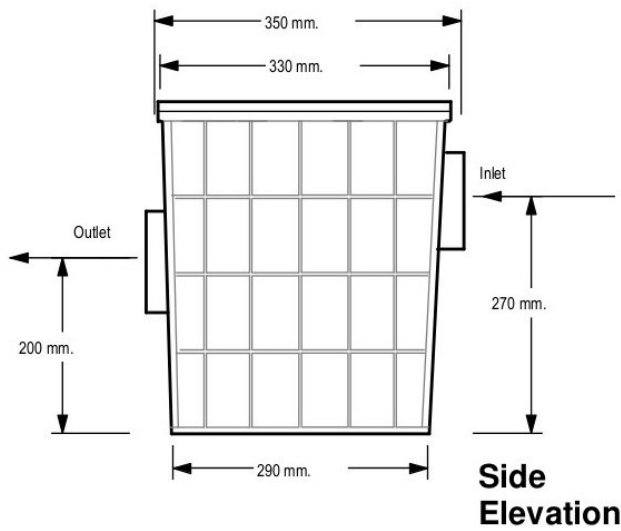

24 WT-01	24 L Water Trap	With 100mm inlets
24 WT-01/40	24L Water Trap	With 40mm inlets

Water Trap 80L

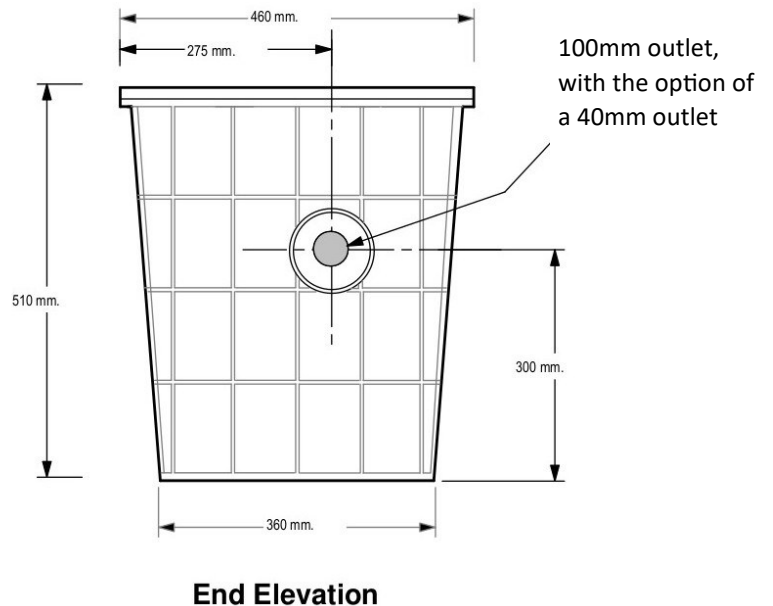
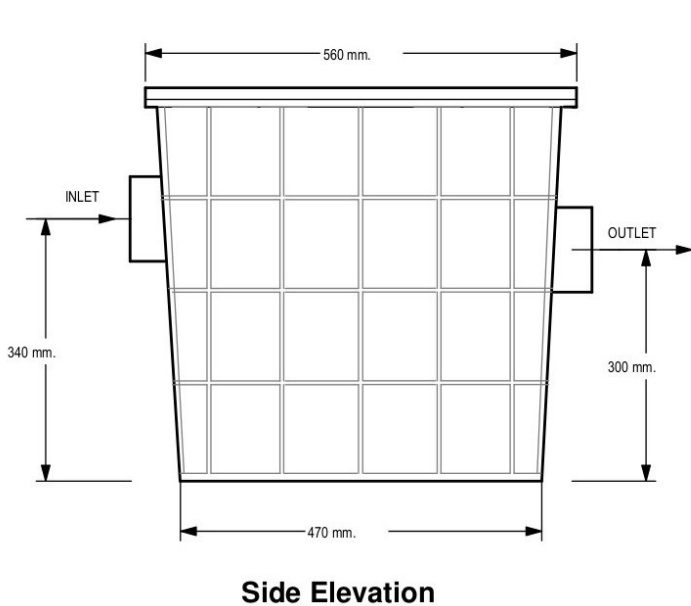

80 WT-01	80 L Water Trap	With 100mm inlets
80 WT-01/40	80L Water Trap	With 40mm inlets

Water Trap 150L

100mm outlet,
with the option of
a 40mm outlet

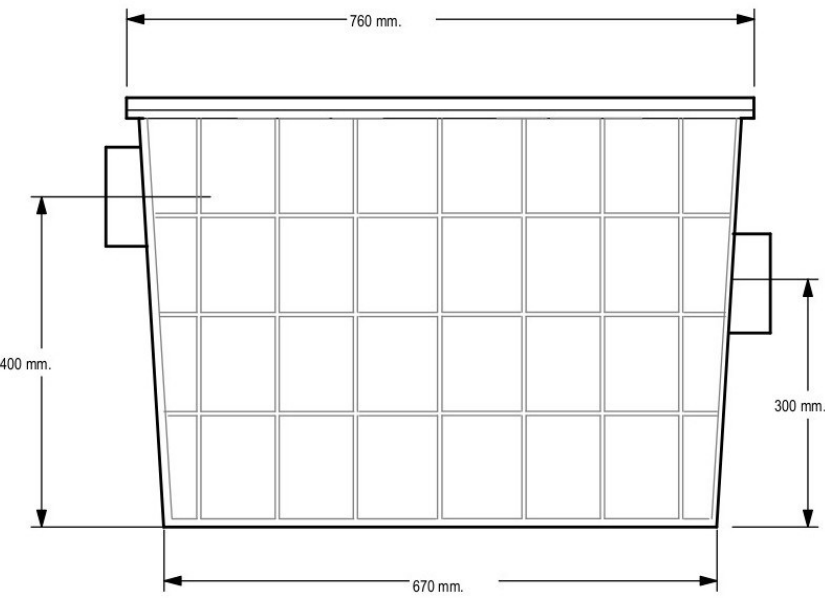

Side Elevation

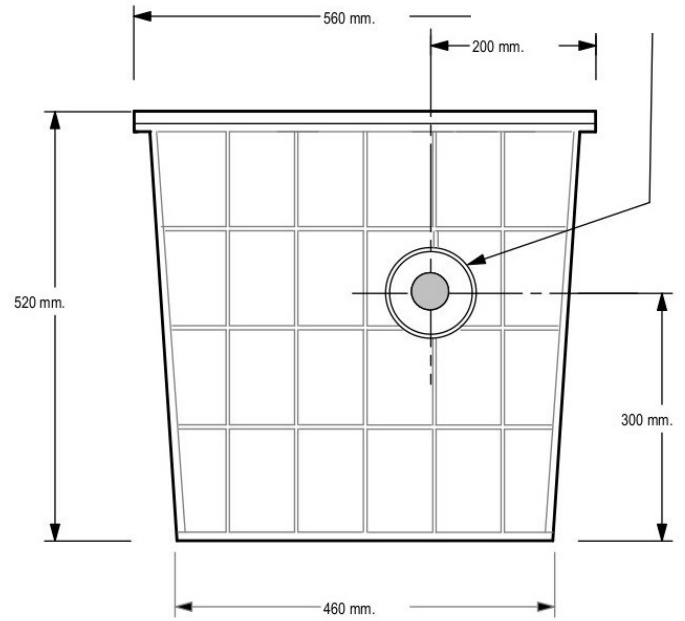

End Elevation

150- WT 01	150L Water Trap	With 100mm inlets
150- WT 01/40	150L Water Trap	With 40mm inlets

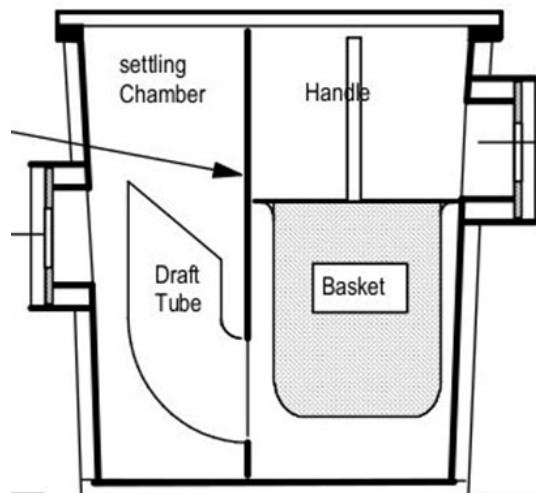

Section



GORILLA PUMP STATIONS

Further and Faster

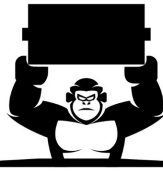

GORILLA PUMP STATIONS
Further and Faster

Vertical 'Y' Non-Return Ball Valve

Transparent For Easy Maintenance

40mm Non-Return Ball Valve

Code: UB40



- Mac Union Fitting
- Cleaning eye for convenient maintenance
- Glued Connections
- Vertical Installation Only

50mm Non-Return Ball Valve

Code: UB50



- Mac Union Fitting
- Cleaning eye for convenient maintenance
- Glued Connections
- Vertical Installation Only