

A Commitment to Quality and Personalized Service



G&F Manufacturing Co., Inc.



BEFCO Manufacturing, Inc.

"Pressure to your Vessels"

ASME MANUFACTURER OF PRESSURE VESSELS, TANKS, AND STEAM JACKETED KETTLES

- ◆ **Pressure Vessels**
- ◆ **Mixing Tanks**
- ◆ **Storage Tanks**
- ◆ **Mixing Kettles**
- ◆ **Sanitary Vessels**
- ◆ **Custom Tanks/Fabrication**
- ◆ **COP & CIP Tanks**
- ◆ **Siphon Fillers**
- ◆ **Piston Fillers**

5555 West 109th Street
Oak Lawn, IL 60453

Toll Free: 1-800-282-1574

Phone: 1-708-424-4170

Fax: 1-708-424-4922

Email: GandF@GandF.com

Website: www.GandF.com





TABLE OF CONTENTS

Types of Vessels	3
Quality Assurance	4
Applications	4
Sanitary Pressure Vessels	5
Industrial Pressure Vessels	6
Open and Closed Top Vertical Tanks	7
Storage Tanks	8
Mixing Tanks	9
Hemispherical Steam Jacketed Kettles	10
Mixers	11
Complete Skid System	12
Complete Assembled Tanks with Stainless Steel Platform	13
Some of our Custom Built Vessels	14
CIP & COP Tanks	16
Siphon & Piston Fillers	17
Specialty Projects	18
Standard Vessels Specifications	19



TYPES OF VESSELS

G&F Manufacturing Co., Inc., has extensive experience and capabilities in the design and fabrication of Stainless Steel Vessels and is readily available to meet whatever your project's criteria are.

Your inquiry will receive our prompt and detailed attention. After a careful review of your concept, design, criteria, and/or drawings; a detailed quotation will be prepared and forwarded to you.

Our many years of experience will simplify the process of concept, quotation, and product manufacture.

The following is a partial listing of some of the custom designed tanks we have manufactured:

- Pressure Vessels
- Batch Tanks
- Reactors
- Distillation Vessels
- Fermentation Tanks
- Vacuum Vessels
- Purified Water Tanks
- Mixing Kettles
- Agitated Tanks
- Jacketed Tanks
- Buffer Tanks
- Storage Vessels
- R&D Vessels

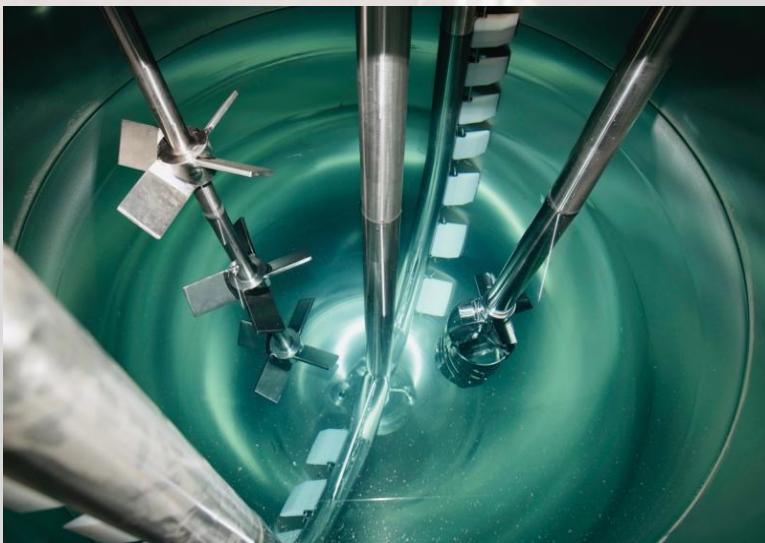

QUALITY ASSURANCE

G&F tanks and processing equipment are built in accordance with the guidelines set forth by the ASME, FDA, GMP, USDA, 3A and UL. Our engineering, manufacturing, and quality control personnel have an unsurpassed industry wide reputation for both product quality and reliability. Every piece of equipment is repeatedly tested during all stages of production to ensure total quality and reliability.

In addition, the customer is always welcome to visit our plant during any stage of the manufacture of their product.

APPLICATIONS

- Food
- Confectionary
- Pharmaceuticals
- Biotech
- Personal Care
- Dairy
- Flavors
- Plastics
- Adhesives
- Epoxies
- Rubber
- Pellets
- Resins
- DI Water
- Paint
- Pigments
- Abrasives
- Water Treatment
- Cleaning Solutions



SANITARY PRESSURE VESSELS



Sanitary design and construction provides easy cleaning and sterilization. Product contact surfaces are polished to remove imperfections from welding and fabrication.

The tank surface can be further polished to a 12 / 5 RA (320 / 400 Grit) finish electropolished and passivated for high purity applications.

Material selection and required sanitary components are furnished based on your specific application. Our engineering staff will design your tanks based upon your application and standards set forth by the ASME, GMP, FDA, 3A, USDA, and UL.

All jackets located on the tank's side walls and bottom can be utilized for heating and cooling. The tank's interior is designed for operating with both vacuum and pressure applications. The removable head is sealed with standard "O" rings and swing bolts to allow for complete access into the vessel.



INDUSTRIAL PRESSURE VESSELS



G&F's craftsmen fabricate pressure vessels and jacketed tanks in accordance with the latest edition of the ASME Code Standards. As required, the vessels can be ASME Code stamped, Section VIII, Div. I and registered with the National Board. Our engineering staff assures the utmost in accuracy when designing your vessel. ASME pressure vessels and jacketed tanks are hydro-tested and examined by an ASME trained and qualified inspector.

HEAT TRANSFER OPTIONS

- Dimple Jacket
- Half Pipe
- Open Jacket
- Internal Coil
- Self Contained Electric Band Heater
- Internal Hot Water Generator



ASME CODE TANK OPTIONS

- Vacuum
- Internal Pressure
- Insulation
- 304L Stainless Steel
- 316L Stainless Steel
- Alloy Fabrication
- Sanitary Design
- Mechanical Seals
- Nozzles
- Gauges
- Gaskets
- Manways



OPEN & CLOSED TOP VERTICAL TANKS

Our extensive line of standard sized tanks allows us to offer short lead times and a very competitive price.

Choose from our many standard models or allow us to custom design a tank to meet your exact needs. We offer a variety of finishes from 2B, No. 4, No. 7 (mirror), to electropolish.

We pride ourselves on our up to date Computer Assisted Design (CAD) engineering group. Our engineers have many years of experience in designing tanks, pressure vessels, and other process equipment. Exacting drawings and photo realistic renderings can be generated and delivered to our customers upon request.

SERIES 'D' (DELUXE VERTICAL TANKS)

- Seamless sanitary construction
- Polished sanitary (No. 4) finish inside and outside
- Complete drainage
- Heavy gauge construction
- Tanks can be supplied with or without mixers
- Heavy duty adjustable pipe legs
- Stainless steel leg sockets eliminate strain and metal fatigue at the tank interface
- Many standard designs allow for fast delivery
- Open top or closed top with manways
- Variety of different bottoms available, i.e., cones,

SERIES 'E' (ECONOMY VERTICAL TANKS)

- Same high quality as D series
- 2B finish is suited for applications where polished surfaces are not required



STORAGE TANKS



20,000 Gallons Capacity Reactor



16,000 Gallons Capacity Storage Tank

FEATURES

- Sizes up to 20,000 Gallons
- Up to 3/4" thick Stainless Steel plate
- 2B and #4 Finish
- Specializing in Custom Configurations



7,500 Gallons Storage Tanks



6,000 Gallons Capacity Storage Tank



MIXING TANKS



Jacketed Mixing Tank with Hydraulic Cover Lift Mechanism



Mixing Tank with Side Entry Mixer



Twin Motion Jacketed Mixing Tanks



Single Motion Vertical Mixing Tank

FEATURES

- Top entering or Side entering Mixers
- Propeller, axial blade, scraped surface, or high shear
- Tanks can be atmospheric or pressurized
- Specializing in Custom Configurations



HEMISPHERICAL STEAM JACKETED KETTLES

- Kettles are built to the latest ASME Code and meet the requirements of the USDA.
- The rim of the kettle is reinforced and the legs are attached by means of heavy-duty load pads to ensure long operating life.
- A sanitary polish (No. 4) inside and out is standard with other finishes such as mirror finish or electropolish available as an option.
- Product outlets can be supplied in a variety of configurations.
- Sizes from 30 Gallons to 10,000 Gallons.



Twin Motion Kettle with Admix High Shear Mixer



IA Inclined Agitator Kettle

AGITATION STYLE

MODEL V

- Kettle without anchor agitator
- Can be equipped with mixer bracket
- Typically used as a holding vessel or for processing low viscosity products

MODEL SA

- Scraped surface anchor agitator
- Heavy duty anchor with removable nylon scraper blades covers all heated surfaces
- Mixing baffles prevent product from moving as one mass

MODEL DMA

- Double Motion Agitator
- Scraped surface agitator and counter rotating inner agitator
- Each agitator has independent drive

MODEL TMA

- Twin Motion Agitator
- Scraped surface agitator
- Secondary paddle agitator

MODEL TMA

- Inclined Agitator
- Scraped surface agitator inclined at a 20° angle
- Agitator lifts product while mixing
- Good for particulate laden products such as soups, stews, pie fillings, etc.



MIXERS

G&F can provide the solution to your mixer needs. From simple portable mixers for low viscosity products to heavy-duty axial blade mixers for large batches and highly viscous products, our fluid mixing engineers can match the proper mixer to your specific application.

PORTABLE & FIXED MOUNT MIXERS MMX SERIES

- Low viscosity or small batch sizes
- Tank sizes from 10 Gallons to 20,000 Gallons
- Viscosity from water-like to 5000 cp
- Air, TEFC or XP motors are available
- Clamp mount or cup plate mount
- Marine propellers

MODEL EDM AXIAL BLADE MIXER

- Tank sizes up to 20,000 Gallons
- Viscosity up to 50,000 cp
- Axial blade design
- Exterior outboard bearing design for shaft rigidity and support
- Optional shaft seals for enclosed tanks
- Shaft seals include stuffing box or mechanical seal design
- Shaft speeds of 60, 120, 230, up to 1800 RPM
- Single piece stainless steel shafts are straightened to 0.003 per foot of shaft length



Gallons	1 cp	100 cp	250 cp	500 cp	1000 cp	5000 cp	Speed
100	0.25	0.33	0.5	0.5	0.75		1750
				0.25	0.33	0.5	430
250	0.25	0.33	0.75	1			1750
		0.25		0.5	0.75	0.75	430
500	0.5	0.75	1				1750
		0.33	0.5	0.75	1	1.5	430
1000	1	1	1.5	3			1750
		0.33	0.5	0.75	1.5	3	430
2000	2	2	3	3			1750
		0.5	1	2	3	5	430

***Up to 20,000 Gallons Custom Built**



COMPLETE SKID SYSTEM



We provide complete skid systems, stationary or on casters, mounted with jacketed ASME Mixing Tanks, Mixers, Pumps, and all necessary process piping and steam piping with heating and cooling unit on one set.

We also provide all technical back-up and thermal calculations for the system.



COMPLETELY ASSEMBLED TANKS WITH STAINLESS STEEL PLATFORM



COMPETENCIES

- Professional Engineering Staff
- 3D Models
- CAD Design/Drafting
- ASME certified welders, “U” & “R”
- Plate fabrication from Stainless Steel and Aluminum
- Complete Electrical Control Systems
- Polishing services to mirror finish

EQUIPMENT FABRICATED

- Hoppers
- Feeders
- Material Handling
- Tanks
- Cyclones
- Screw Conveyors
- Stacks
- Condensers
- Evaporators
- Piping Systems
- Pumping Systems
- Fillers
- Specialized Equipment for the Food, Chemical, and Pharmaceutical Industries



SOME OF OUR CUSTOM BUILT VESSELS





CIP & COP TANKS

G&F **CIP (Clean-In-Place)** tanks provide an automated method of cleaning the interior surfaces of pipes, vessels, equipment, and associated fittings, without major disassembly. CIP is commonly used for equipment such as piping, tanks, and fillers. CIP employs turbulent flow through piping, and/or spray balls for large surfaces. In some cases, CIP can also be accomplished with fill, soak and agitate.

The CIP systems are meant to deliver highly turbulent, high flow-rate solution, and high energy impinging spray to cause good cleaning.

The benefit to industries that use CIP is that the cleaning is faster, less labor-intensive and more repeatable, and poses less of a chemical exposure risk.

Industries that rely heavily on CIP are those requiring high levels of hygiene, and include: dairy, beverage, brewing, pharmaceutical, cosmetics, processed foods, etc.



CIP Tanks



COP Tank

The purpose of G&F **COP (Clean-Out-Of-Place)** tanks is to hold mild caustic and chemical wash solutions. All these solutions are supplied to the tank through a circulation system.

Components being washed are submerged in the wash solutions and can be either loose or in removable part baskets. COP systems are used to clean pieces of equipment that wouldn't be cleaned by the CIP system. Equipment could include fittings, clamps, product handling utensils, pump rotors, impellers, casings, hoses, etc.



SIPHON & PISTON FILLERS

G & F made **J-1 Siphon-Fillers** are used in applications for acids, chemicals, cologne, cosmetics, detergents, extracts, foaming liquids, juices, liquid soaps, liquor, medicines, oils, shampoo, solvents, syrups, vinegar, wine and many other liquids.

- An economical unit for medium and small production filling.
- Fills containers ranging in size to 1 gallon
- Free-flowing and low viscosity liquids of virtually all types are readily handled.
- Uniform fill improves package appearance.
- Unskilled operators keep operating costs at a minimum
- Ruggedly built for years of lasting satisfaction
- Quality workmanship insures accurate and dependable operation

For maximum production, 8 Spouts are generally used for most container sizes up to and including quarts. 5 spouts are recommended when handling half gallons and gallons. Selection of filling nozzle size depends principally on the size of the container and mouth opening. The filler will handle from 3 to 30 containers per minute depending upon the product, size of container, and nozzle size required.



Siphon Filler



Piston Filler

G&F's pneumatically operated bench model **Piston-Fillers** are designed to fill 1 oz to 128 oz jars.

1. All stainless-steel tri-clover fittings makes it easy for disassembling and thorough cleaning.
2. All contact parts and base are made from stainless steel.
3. Piston fillers dispense viscous products through autoclavable drip free nozzle.
4. Piston fillers are pneumatic, and the drawing and filling speeds can be varied. They do not require a 12-gallon hopper, although they are available as an optional item.

Piston-Fillers will require a compressor with an air supply of 4.0 cubic feet /minute.

G&F Piston Fillers are ideal for filling: Liquids, Thick creams, Gels, Pastes, Sauces, etc.



SPECIALTY PROJECTS

G&F Manufacturing Co., Inc., is also involved in projects in an around the community. The 50 ft. high Stainless Steel Sailboat we built in Algonquin, Illinois (Suburb of Chicago) is an example of it.

The entire structure was designed and fabricated at our facility in Oak Lawn, Illinois, and this successful project was delivered as a gift to the community.



STANDARD VESSELS SPECIFICATIONS

RATED CAPACITY (GAL)	US GALLONS (ACTUAL)	RATED CAPACITY (LITERS)	LITERS (ACTUAL)	DIAMETER "A"	LENGTH OF SHELL "B"	FLOOR CLEARANCE	NUMBER OF LEGS	TYPICAL PIPE SIZE	APPROX. WEIGHT IN LBS. (NET)
30	36	113	136	21"	24"	37"	3	1"	52
60	63	227	238	22.75"	36"	49"	3	1"	70
100	114	378	431	30.5"	36"	49"	3	1"	90
120	137	454	518	31"	42"	55"	3	1"	120
160	176	605	666	38"	36"	49"	4	1"	120
200	235	757	890	38"	48"	61"	4	1"	150
300	341	1136	1290	45.75"	48"	61"	4	1"	185
400	427	1514	1616	45.75"	60"	73"	4	1.5"	215
500	551	1893	2085	52"	60"	73"	4	1.5"	245
600	680	2271	2574	57"	60"	74.5"	4	1.5"	340
800	850	3028	3217	64"	60"	74.5"	4	1.5"	380
1000	1114	3785	4216	67"	72"	85"	5	1.5"	475
1250	1323	4731	5008	73"	72"	85"	5	1.5"	730
1500	1686	5678	6382	76"	84"	99.5"	5	1.5"	850
2000	2150	7570	8138	86"	84"	99.5"	6	2"	1010
2250	2304	8517	8721	84"	96"	111.5"	6	2"	1100
2500	2685	9463	10163	90"	96"	112"	6	2"	1200
3000	3023	11356	11443	95"	96"	112"	6	2"	1280
3500	3768	13248	14263	95"	120"	136"	6	2"	1530

*We have the capacity to custom build up to 20,000 Gallons Vertical and Horizontal pressure and storage vessels.

PROMINENT FEATURES:

1. Heavy Gauge Seamless Construction.
2. Manways and Covers.
3. Removable Steel Pipe Legs with Adjustable Floor Flanges or Cradles.
4. All Types of Fittings Available.
5. Deluxe Vessels: Polished Finish Throughout.
6. Economy Vessels: 2B Finish Inside and Outside, with Inside Welds Ground Flush and Polished. Outer Welds have Heat Marks and Burrs Removed.

Horizontal Pressure Vessels are specially suited for all applications when the height of the vessel is a major consideration.

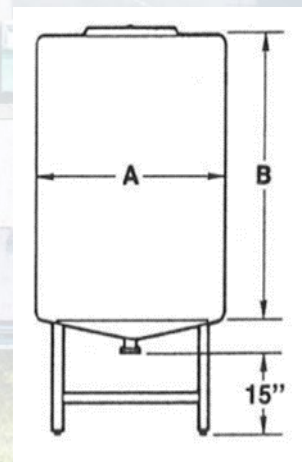

A Commitment to Quality and Personalized Service



G&F Manufacturing Co., Inc.



BEFCO Manufacturing, Inc.

"Pressure to your Vessels"

ASME MANUFACTURER OF PRESSURE VESSELS, TANKS, AND STEAM JACKETED KETTLES



**5555 West 109th Street
Oak Lawn, IL 60453**

Toll Free: 1-800-282-1574

Phone: 1-708-424-4170

Fax: 1-708-424-4922

Email: GandF@GandF.com

Website: www.GandF.com

