

## Care and Operation Manual

### Warranty and Service Instructions For The Following Models

#### Superior Fireplace MODELS

RD-3300	CR-3830R
RD-3800	CR-3830L
RD-4300	CF-3860
RC-3310	M-3850
RC-3810	M-3855
RC-4310	FC-3880
HC-3320	FR-3870
HC-3820	TM-4500
HC-4320	PF-9000
HCE-3550	ST-3840
HCE-4050	PR-7800
HCE-4550	1038
	1043

#### Hearthstar Fireplace MODELS

33A	33B
38A	38B
43A	43B
35B-N	38H
40B-N	
45B-N	

The information contained in this manual applies to all the model fireplaces identified on this page. This information will help you obtain safe and dependable service from your Superior or Hearthstar fireplace system. Keep this document in a safe place for future reference.

Before your first fire, read this Care and Operation Manual carefully to be sure you understand completely. Forward your warranty registration card without delay to ensure proper registration of your warranty. Failure to follow these suggestions could result in hazardous operation or fireplace malfunction, creating a serious potential for bodily injury and/or property damage.

If you have any questions regarding the safe use or operation of your fireplace, contact Superior Fireplace Company before use.

**PLEASE RETAIN  
MANUAL FOR FUTURE  
REFERENCE.**

**IMPORTANT**  
THE MODEL NUMBER OF YOUR FIREPLACE CAN BE FOUND STAMPED ON THE RATING LABEL GENERALLY LOCATED BEHIND THE SCREEN ASSEMBLY. REFER TO THIS MODEL NUMBER WHEN FILLING OUT YOUR WARRANTY REGISTRATION CARD AND IN REFERRING THE DIFFERENT OPERATIONAL MODES AS OUTLINED IN THIS MANUAL.

## CARE AND OPERATION GUIDE

If you aren't already a fireplace expert, these quick pointers will explain the main features of your Superior fireplace:

1. The all-steel, multi-wall firebox is the heat center of the system. It is well insulated for safe zero clearances to combustibles.
2. The hearth floor of the firebox is a brick patterned reinforced refractory base for your fire. On certain models, the refractory sides and rear of the firebox are designed for authenticity and safety.
3. The metal chimney sections extending from the firebox top to beyond your roof are two walled and air-cooled. The inner passage, or flue, provides the exit for smoke and gases.
4. The flue damper is fully opened or completely closed by the handle you find in the center and top of the firebox. It must be open when the fire is burning so smoke and gases can escape. It should be closed when the fire is completely out – keeping room air from being lost up the flue.
5. The screens prevent fire, sparks and embers from popping out of the firebox when a fire is burning and the glass doors are open (if installed). Pull screens back when adding wood to your fireplace.
6. On certain models the innovative firebox design, with its unique slanted rear refractory construction, maximizes heat output.
7. Why use a fuel grate? It's important in the use of your Superior fireplace. Besides positioning the firebed properly, it protects the refractory floor, back and sides of the fireplace. Further, it ensures a proper flow of combustion air into and around the firebed, producing the hottest type of fire and maximum burning efficiency. The Superior grate, if provided with your fireplace must be used at all times when burning.

Your warranty may be voided without the use of this grate.

## OPERATING YOUR SUPERIOR FIREPLACE

Remember, you are going to build a HOT FIRE in your house, so be careful to observe the precautions and operation tips included in this Guide.

Always make certain the damper is OPEN when a fire is burning and that the chimney system is clear.

Remember, too, that the heating efficiency and output of your Superior fireplace – and your comfort satisfaction – will depend on how hot your fire is. And, this will depend on how you build and tend your fires.

This Guide will help you in this MOST IMPORTANT part of successful fireplacing.

## WARRANTY/REGISTRATION CARD

Both Superior and Hearthstar models are covered under the Superior Limited Warranty in this guide. Also, an Owner's Registration Card is included inside your Superior fireplace. Please read our Warranty to be familiar with its valuable coverage – and file it with others you save for future reference. Also, complete and mail the Warranty Registration Card.

## GENERAL SAFETY PRECAUTIONS

**IMPORTANT: Read before your first fire!**

1. Use SOLID wood only for fuel. Use dry and well seasoned woods. Softwoods tend to burn too quickly. Scrap construction lumber produces excessive sparks. DO NOT use artificial logs, charcoal, coal, trash or woods that have been dipped in tar, pitch, creosote, etc. Wood products made with synthetic binders, such as plywood and artificial logs produce abnormally high temperatures and sputtering smoking fires.
2. NEVER use gasoline, gasoline-type lantern fuel, kerosene, charcoal lighter fluid or any such explosive type solvents to start your fire or "freshen up" a fire in this fireplace. Keep all such liquids well away from the fireplace while it is in use. Never use an outdoor grille or charcoal in this fireplace as deadly carbon monoxide fumes can develop.

3. Keep the chimney damper open while any fire or smoldering embers are present.
4. Never block the room air intake grille across the bottom front or warm air outlet grille across the top front of the fireplace.
5. With the fireplace burning and doors open (if installed), close the protective mesh screen to keep sparks and embers INSIDE the firebox.
6. Keep any combustible objects like furniture or decorative pillows at least 36" (914 mm) from the fireplace opening.
7. Never leave your fireplace unattended while it is burning.
8. Be careful adding wood fuel to the fire or handling fireplace tools such as shovels, tongs and pokers.
9. Never modify or alter your fireplace system in any way! To do so may create a fire hazard and void your Superior warranty.
10. The bottom refractory can be cracked by excessive abuse such as tossing heavy logs onto the grate or gouging with fireplace tools. Exercise care when adding wood to your fireplace.
11. Superior does not recommend the use of retrofit devices by other manufacturers for their fireplaces. These devices include, but are not limited to non-listed glass doors, heat tube exchangers, inserts, outside air kits, chimney tops and air movement devices. Superior can not test all possible combinations of these products offered for sale to verify safety. Also, Superior can not verify the suitability of these products for use in Superior products. Superior is not responsible for, and Superior warranties do not cover, the products of other manufacturers or any loss or injury caused by or directly resulting from a defect in those products.
12. If you are using your Superior fireplace as a "decorative appliance," such as with a permanently installed gas log set, the fireplace damper must be permanently fixed in the fully open position.

## DISPOSAL OF ASHES

Ashes should be placed in a metal container with a tight-fitting lid. The closed container of ashes should be placed on a non-combustible floor or on the ground, well away from all combustible materials, pending final disposal. If the ashes are disposed of by burial in soil or otherwise locally dispersed, they should be retained in the closed container until all cinders have thoroughly cooled.

## GLASS DOOR SAFETY PRECAUTIONS

Superior offers glass door enclosures in two different styles, twin pane and bi-fold design. With the exception of the PF and PR series, which are twin pane design doors, all other Superior glass doors employ tempered glass. The PF and PR series doors employ a ceramic type glass (neocerem). While this type of glass is designed to withstand very high temperatures, up to 1500° F, it is still subject to breakage due to impact, much like conventional glass. Exercise caution so as not to subject this ceramic glass to impact. The ceramic type glass is not covered by our warranty while in use and it is very expensive to replace.

**WARNING: IF YOUR FIREPLACE, OTHER THAN A ST OR PF SERIES IS EQUIPPED WITH SUPERIOR GLASS DOORS, IT SHOULD BE OPERATED ONLY WITH THE DOORS FULLY OPEN OR FULLY CLOSED. IF THE DOORS ARE LEFT PARTLY OPEN, GAS AND FLAME MAY BE DRAWN OUT OF THE FIREPLACE OPENING, CREATING RISKS OF BOTH FIRE AND SMOKE.**

**THE ST-3840 FIREPLACE SHOULD BE OPERATED ONLY WITH BOTH SETS OF DOORS FULLY OPEN OR FULLY CLOSED. IF THE DOORS ARE LEFT PARTLY OPEN, GAS AND FLAME MAY BE DRAWN OUT OF THE FIREPLACE OPENING, CREATING RISKS OF BOTH FIRE AND SMOKE.**

**THE PF-9000 FIREPLACE SHOULD BE OPERATED ONLY WITH BOTH SETS OF DOORS FULLY CLOSED. IF THE DOORS ARE LEFT EITHER OPEN OR PARTLY OPEN, GAS AND FLAME MAY BE DRAWN OUT OF THE FIREPLACE OPENING, CREATING RISKS OF BOTH FIRE AND SMOKE. REFER TO FIGURES 1, 2, 3, 4 and 5 FOR PROPER DOOR OPERATING CONDITIONS.**

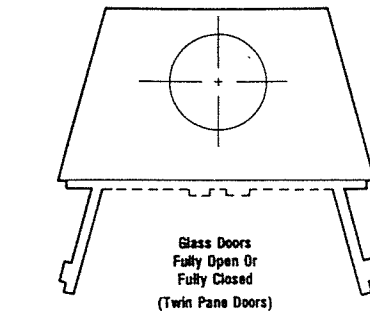

Figure 1

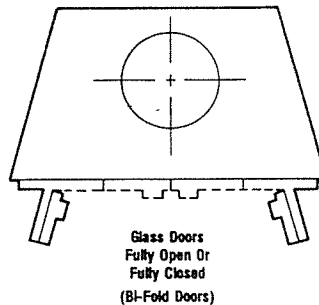

Figure 2

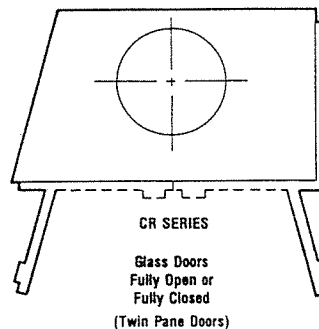

Figure 3

## NEVER USE COAL IN YOUR FIREPLACE

Your Superior fireplace system is not designed to be used with coal derivative products. The combustion process of certain type of coal can deposit corrosive materials in the fireplace and chimney system which may lead to premature product failure. Never use coal as a fuel in the Superior fireplace system.

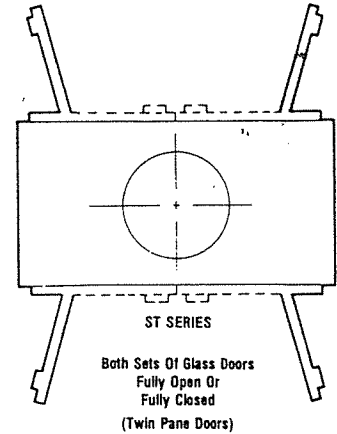

Figure 4

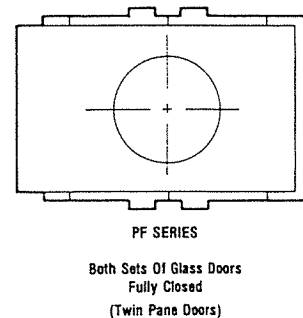

Figure 5

## WOOD FUEL POINTERS

Wood is a marvelous renewable source of fuel. Normally, it burns clean, leaving only a minimum of waste ash; provides comforting heat and can provide a variety of aromas and visual images.

Because you want your fireplace to operate efficiently, you should know which woods are best for faster burning. You may want a quick, hot, short fire to offset morning chill - other times, more slow burning, uniform heat output for overnight or a weekend at home. In the first example, soft wood is preferable; in the second, hardwood.

## SOFTWOOD VS. HARDWOOD

All woods contain flammable resins which can generate creosote in a chimney flue. Burning too much softwood isn't as desirable as using the more dense hardwoods. Many experienced fire-builders use small amounts of softwood kindling, small sticks and newspapers together with hardwood logs. Here are some quick guidelines to remember about the characteristics of wood:

1. Softwoods produce fast warming fires of short duration. Hardwoods burn less vigorously, have a shorter flame and produce steady, glowing coals.
2. As a general rule, denser woods contain more potential heat per log. Most softwoods offer moderate heat value per pound.
3. Different woods vary widely in flame heights and intensities, smoke characteristics and in sparking. (MOST hardwoods do not spark, for example).
4. "Smoke aroma" is best from woods of fruit and nut trees such as apple, cherry, beech, hickory and pecan. A little more expensive for the nostalgic effect.
5. Most freshly cut "green" wood will not burn well and will smoke. Further, green wood can range from 10 to over 40 percent less efficient in producing heat than does a dried seasoned wood.
6. Moisture inside UNSEASONED wood cells builds steam pressure under heat and explode as sparks which can be unsafe and annoying.
7. Most woods need seasoning to reduce moisture content in order to produce good steady fires. When a green wood is reduced in moisture content from 60% to 20%, the gain in heat potential is nearly 7%. If three months of seasoning reduces the moisture content to only 35%, this is still not enough for the smooth-burning fires you expect. Longer wood seasoning, preferably a year, is essential - never on the ground or it will rot. Raise with flat stones or scrap wood.
8. Be a knowledgeable wood buyer. There is a difference in cords. A STANDARD CORD stack of logs 4' high by 8' long by 4' deep - or its equivalent. A FACE CORD is the same except the depth is only the length of the logs - 12, 16 or 24 inches - and far less cubic feet than a standard cord. Usually, a stacked cord contains about 90 cubic feet not 128, due to the spaces between the logs. The volume of solid wood depends on care in piling, log thickness and whether round or split. If you buy by the ton, remember wood shrinks as it dries. When buying green or wet wood, ask for some extra measure to allow for the EXTRA water you'll be getting.
9. In storing wood outside, keep UNDER ROOF or COVERED with plastic - and up off the ground, of course. A wood box or wicker basket near your fireplace will be most handy and keep things neat and attractive.

## STARTING A FIRE

To start a fire in your Superior fireplace properly:

a. First, check the operation of the flue damper. The design of the flue damper assembly varies for some model fireplaces. For all front opening and corner opening fireplaces with exception of the TM series, the damper is activated by a center mounted handle. The damper is opened by pulling the handle forward. To close the damper, the handle is pushed all the way to the rear of the firebox. The damper is NOT ADJUSTABLE between the open and closed position. The TM-4500 fireplace damper works in the opposite manner. The damper is opened by pushing the handle to the rear of the firebox. To close the damper, the handle is pulled all the way to the front of the firebox. The damper handles on the PF-9000 and PR-7800 fireplaces are attached vertically in the center of the fireplaces. To open, twist the handles either clockwise or counter clockwise and push up on handle. To close, pull handle down and twist handle  $\frac{1}{4}$  turn either clockwise or counter clockwise. To open the damper on the ST-3840 fireplace, push the damper handle and release. To close, pull down handle and pull toward you to the locked position. Close your flue damper only when the fire is completely out.

b. The grate in the firebox should be centered on or over the bottom hearth so your fire can breathe properly. Crumple and twist plenty of newspapers UNDER the grate and criss-cross some small, dry kindling sticks on top of the paper or on the bottom of the grate

c. Build a pyramid of three logs (split will start much better). Arrange the uneven wood to provide air space between.

d. Now, light the paper at both sides of the firebox.

e. Close screen to prevent escape of sparks and embers.

f. Close damper completely only when your fire is completely out and ashes are cold. Keep closed when fireplace is not in use to prevent unnecessary loss of heated or cooled air. Close glass doors whenever fireplace is not in use. We recommend burning your fire with both sets of doors closed.

## COMBUSTION AIR

A proper amount of combustion air is important for your fireplace. Fireplaces consume large amounts of oxygen, and it is important to allow an adequate supply of air from the area surrounding the fireplace. If the fireplace is not equipped with an outside air kit and can not obtain a sufficient amount of air from inside the house or structure in which it is installed, the only other air source is outside air which may be pulled in through the fireplace chimney, which may cause smoke spillage from the firebox into the room. Smoke spillage often occurs when a fire is first started, until the fireplace and the chimney have had an opportunity to "come up to temperature" and to begin to function normally. If smoke spillage problems persist, a window may be opened just a crack to allow the proper flow of combustion air to the fireplace.

If your fireplace is equipped with outside combustion air, keep open at all times while fire is burning and close when fire is out to prevent cold air intrusion into the home from outside.

*Note: See page 6 for directions on use and operation of your Superior Combustion Air Kit.*

## REFRACTORIES

All fireboxes contain a furnace refractory floor. Some models also have refractory sides and back. These refractories are reinforced with steel, but can be broken with improper use. Dropping logs on the bottom refractory and building fires directly against the refractories can cause damage and premature burnout of these components. It may easily be repaired or replaced at costs far below repair and maintenance costs for masonry-built fireplaces.

Proper care and "burn-in" of the firebox will prolong the period of enjoyment without maintenance. For the first few fires, build small fires - not roaring infernos. The materials used in the refractories of your fireplace contain and absorb moisture. It is important to "cure" the refractories in the first use of the fireplace by building only modest fires. Under normal usage, it is expected that hairline cracks will appear in the refractory surface. These hairline cracks do not affect the safe operation of the fireplace.

Refractories should be replaced when:

- a. The crack opens more than  $\frac{3}{16}$ " (4.76 mm).
- b. Pitting in the surface is extensive and pits become deeper than  $\frac{3}{16}$ " (4.76 mm).
- c. Any piece of refractory larger than 1" (25 mm) in radius and  $\frac{3}{16}$ " (4.76 mm) deep becomes dislodged

If your refractory has a crack less than  $\frac{3}{16}$ " (4.76 mm) in width, Superior will supply you at no charge under the provisions of your factory warranty, a simple refractory patch kit (RPK) which can be easily used to fill the crack and repair the refractory to its original appearance.

## Care and Operation

If any conditions (a), (b), or (c) occur, the fireplace should not be used until the refractory is replaced, if appropriate, or repaired as noted above.

### MAINTENANCE GUIDELINES

Your fireplace is engineered to operate trouble-free with minimum maintenance. However, like any other fine "appliance", it deserves and requires some housekeeping attention.

Cleaned before EACH USE, your fireplace will perform better – and certainly look more attractive to family and friends. Before the FIRST SEASONAL USE in autumn and after the LAST FIRE IN SPRING, it is important to inspect the fireplace system carefully. We recommend at least two complete fireplace inspections a year.

### BEFORE EACH USE

1. Clean the firebox of excessive ashes. Some owners prefer to leave a small layer to insulate the cold refractory below the grate which helps the fire start more easily.

If your particular model fireplace has a factory-supplied grate attached, it is permissible to remove the grate to facilitate cleaning; however, the grate must be re-attached to the fireplace before the next fireplace burn.

2. Keep the fireplace screens clean so combustion air flows freely when the fireplace doors are open if installed.

3. Spot check the brick-like refractory slab for small cracks. Heat from the fire expands it slightly. When cool, it contracts.

### TWICE A YEAR CHECK-UP

Normally, twice a year, you should inspect your fireplace, following this check-up list:

1. Inspect the opening in your chimney top and remove any objects that could clog it. The cap is usually held by 4 screws, which remove easily for checking or cleaning the full length of the chimney from above. Remove chimney top while wearing gloves to guard-against any sharp metal edges.

2. Inspect the entire flue from the top for obstructions such as bird nests, leaves, etc. This may be done easily by using a strong flashlight.

3. Look up from inside the fireplace (damper open) to see any obstruction in the lower flue area. If present, shut the damper and glass doors (if installed) to seal the firebox and contain the soot that may fall. If you do not have doors installed, a damp sheet covering the fireplace opening and sealed with masking tape will do. Then clean the flue from the top using a proper size chimney brush with flexible pole sections. (Don't open the doors or remove sheet until all the soot has settled. Vacuum, don't sweep.)

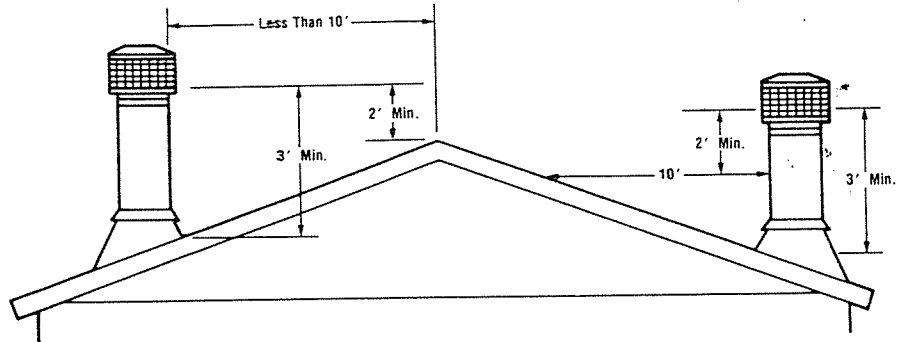

Figure 6

4. Check the metal flashing and seals around your chimney. Seal any cracks or loose nailhead openings to prevent roof leakage.

5. Clean the firebox thoroughly by using a soft brush or equivalent.

**WARNING: CONTINUED OVERFIRING CAN PERMANENTLY DAMAGE YOUR FIREPLACE SYSTEM. SOME EXAMPLES OF OVERFIRING ARE:**

- QUANTITIES OF SCRAP LUMBER, PINE BRANCHES, PAPER OR CARDBOARD BOXES WHICH EXCEED THE VOLUME OF THE "NORMAL LOG FIRE".
- USE OF ARTIFICIAL LOGS, TRASH, OR OTHER CHEMICALS OR CHEMICALLY TREATED COMBUSTIBLES.

### CREOSOTE FORMATION AND NEED FOR REMOVAL

When wood is burned slowly, it produces tar and other organic vapors, which combine with expelled moisture to form creosote. The creosote vapors condense in the relatively cool chimney flue of a slow-burning fire. As a result, creosote residue accumulates on the flue lining. When ignited, this creosote makes an extremely hot fire.

The chimney should be inspected at least twice monthly during the heating season to determine if a creosote build-up has occurred.

If creosote has accumulated, it should be removed to reduce the risk of a chimney fire.

### TROUBLE SHOOTING

#### No Smoking Allowed

Your new fireplace is designed not to smoke if properly installed and operated per our instructions. If you do experience a problem, here are several things to check:

1. Remember – always check to ensure your flue damper is in the open position before lighting a fire!

2. When lighting your fire, a little smoke may escape into the room: – more likely if the chimney is cold. To correct, hold a lighted newspaper up inside the firebox near the OPEN flue damper. This will turn around almost any downdraft and clear the flue of cold air. And as your log fire burns below, the updraft will improve as the chimney heats up. You will also know that your chimney is clear of any unsuspected obstruction.

3. Is your fire too far forward? Move it toward the back with your poker. Keep the fire in the middle of your fuel grate.

4. Keep your fire UP ON the grate and the refractory below clear of EXCESSIVE ashes. The fire needs plenty of air movement around the logs.

5. If smoking occurs an hour or two AFTER fire lighting, perhaps your well-insulated house is too airtight and there is scarcely any way for replacement air to enter and feed the fire. Check to see if your outside combustion air kit (if installed) is open. Check outside to ensure no obstructions are in front of exterior air entry. Open a window slightly, open the doors to one or two rooms and see if this stops the smoking. Both you and the fire need air.

6. Is a fan vent, exhaust hood or a central heating system forced air return stealing combustion air from your fireplace? If their volume is high enough, this can cause negative pressure and an unwanted downdraft – and smoking.

7. Is your wood fuel too unseasoned or wet? Or, does it contain some chemical substance that causes sputtering, smoking and toxic fumes?

8. (See Figure 6). This illustrates the correct height of your chimney top. It is unlikely that your installation does not adhere to installation instructions. However, if not correct, you could experience an unusual downdraft. Usually, the best solution is to increase the chimney height. This may also be necessary if nearby trees or a hill is causing a downdraft condition.

9. Remember, your fireplace has been designed as a supplemental heat device only; it is not expected to heat your entire home.

## COMBUSTION AIR CONTROL

The operation and location of the outside air control lever varies to some extent on different fireplace models. On Superior RD, RC, HC, CF, HCE, FR, FC and M Series fireplaces and Hearthstar A, H, N and B Series fireplaces, the control lever is located on the left hand side of the fireplace behind the firescreen panel if your fireplace is equipped with the optional combustion air kit.

To open the air damper, pull the lever all the way out. To close the air damper, push lever all the way in. (Refer to figure 7).

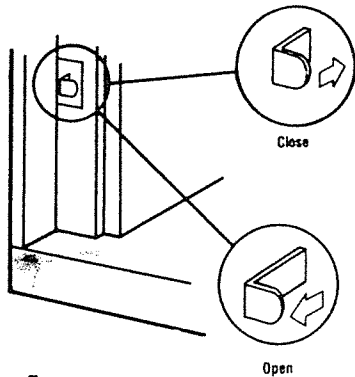

Figure 7

On Superior's 1000, TM, ST (Figure 8), and PF (Figure 9) Series fireplaces the control lever that operates the outside combustion air valve has been preinstalled on your fireplace. A coverplate has been mounted over this control lever only if the outside air kit has not been attached. The control lever is located on the left hand or closed side of the fireplace behind the firescreen. The operation of the control is the same as the previous models.

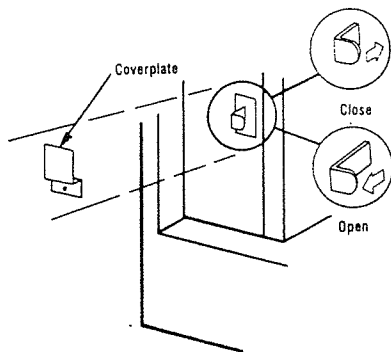
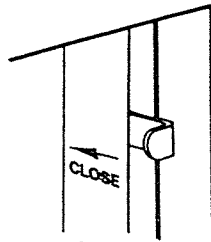
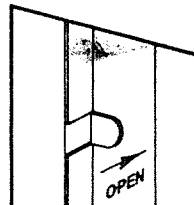

Figure 8



Open Position  
Shown

Right Side



Open Position

Left Side

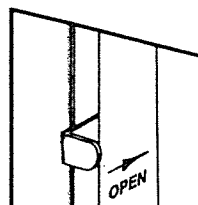

Closed Position

Figure 9

On Superior's CR series fireplaces, the control lever that operates the outside combustion air valve has been preinstalled on your fireplace. A coverplate has been mounted over this control lever only if the outside air kit has not been attached. The control lever is located on the closed end of the fireplace behind the screen panel. To open the air damper, turn the lever handle 1/2 turn counterclockwise (or until lever can be moved upward), then retighten at desired open position. To close damper reverse procedure. (Refer to figure 10)

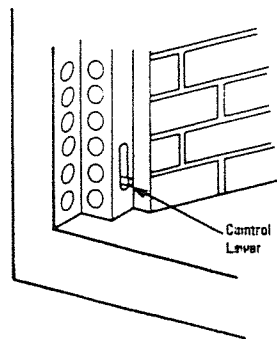

Figure 10

The control lever is preinstalled on the PR series fireplace and is located above the rear refractory. This lever is best operated with a fireplace poker. To open the air damper, push the lever to the left. To close the air damper, push the lever to the right. (Refer to figure 11).

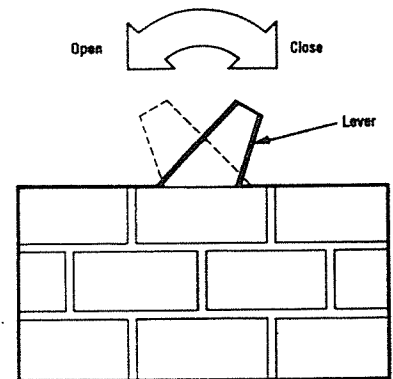

Figure 11

The outside air damper should be kept closed on all fireplace models except when the fireplace is in operation. The air damper should be closed at night before retiring to prevent intrusion of outside air into the home.

## ENJOY YOUR SUPERIOR FIREPLACE

So, congratulations on your new fireplace and happy fireplacing. Please mail your warranty card promptly. If you have any questions, please do not hesitate to contact:

## SUPERIOR FIREPLACE COMPANY

Special Services Coordinator  
4325 Artesia Avenue  
Fullerton, California 92633  
714-521-7302



# Superior Factory-Built Fireplaces Limited Warranty 25 Years

## THE WARRANTY

Superior Fireplace Company warrants the components of this factory-built fireplace system manufactured by Superior Fireplace Company (Superior Fireplace System) to be free from defects in materials and workmanship at the time of manufacture.

This Warranty begins on date of installation for this factory-built fireplace system manufactured by Superior Fireplace Company (Superior Fireplace System).

## REMEDY AND EXCLUSIONS

The coverage of this Warranty is limited to all components of the fireplace system manufactured by Superior Fireplace Company with the exception of Superior tempered glass doors. Ceramic glass doors manufactured by Superior Fireplace Company are not warranted. Superior Fireplace Company warrants the components of this factory-built system manufactured by Superior Fireplace Company (Superior Fireplace System) to be free from defects in materials and workmanship at the time of manufacture.

The Warranty only covers Superior Factory-built fireplace systems manufactured by Superior Fireplace Company (Superior Fireplace Systems) installed in the United States or Canada. If the factory-built fireplace system manufactured by Superior Fireplace Company (Superior Fireplace System) covered by this Warranty is found to be defective (see Superior's right of investigation outlined below), Superior will, at its option, provide such replacement or repair components of the factory-built fireplace system manufactured by Superior Fireplace Company (Superior Fireplace System) as is necessary to cure any defect in accordance with the following schedule:

1) During the first five years of this Warranty Superior Fireplace Company will, at its option and except for the components listed in subparagraphs (a) through (c), below, provide replacement or repair components of the Superior factory-built fireplace system manufactured by Superior Fireplace Company (Superior Fireplace System), at no charge and will also pay for reasonable labor costs incurred in replacing or repairing such components. If repair or replacement is not commercially practicable Superior will, at its option, refund the purchase price of the Superior Fireplace and Superior Chimney Components and Accessories. With respect to the components listed below, the remedies of this paragraph (1) are available only for the period of time indicated. Thereafter, however, until the expiration of 25 years from date of installation, Superior Fireplace Company will, subject to the conditions of paragraph (3) below, provide replacements or repairs for those components at 50% off the then prevailing factory list prices for those components.

- a. Fireplace cast iron or steel fuel grates are considered consumable accessories and therefore are not warranted, with the exception of defects in material or workmanship.
- b. Fireplace screens, refractories and side shields (metal or refractory) — two years from date of installation.
- c. Fireplace electrical components such as fan motors and blowers — five years from date of installation.

2) During the sixth through tenth year of the Warranty, Superior Fireplace Company will, at its option, provide replacement or repair components at no charge, except as is provided for the components listed in subparagraph (a) through (c) above. This coverage provides for parts only and does not include any labor.

3) During the eleventh through the twenty-fifth year of the Warranty, Superior Fireplace Company will, at its option, provide replacement or repair components at 50% off the then prevailing factory list prices for those components. This coverage only provides for the purchase of replacement or repair components at discount and does not include any labor.

This Warranty covers only parts, and in some instances labor (as provided in subparagraph (1) above). In no case shall Superior Fireplace Company be responsible for materials, parts or construction which were not manufactured or supplied by Superior Fireplace Company or for the labor necessary to install, repair, or remove such materials, parts or construction. All replacement or repair components will be shipped F.O.B. the nearest Superior Fireplace Company factory.

## QUALIFICATION TO THE WARRANTY

The complete fireplace Warranty outlined above is further subject to the following qualifications:

1) The factory-built fireplace system manufactured by Superior Fireplace Company (Superior Fireplace System) must be installed in accordance with Superior Fireplace Company installation instructions and local building codes. The Warranty on this Superior factory-built fireplace system manufactured by Superior Fireplace Company (Superior Fireplace System) covers only the component parts manufactured by Superior Fireplace Company. The use of components manufactured by others with this Superior Fireplace System could create serious safety hazards, may result in the denial of certification by recognized national safety listing agencies, and could be in violation of local building codes. This Warranty does not cover any damages occurring from the use of any components not manufactured or supplied by Superior Fireplace Company. Any modification to the system or the retro-fitting of any appliance to the system which alters the function or performance of the fireplace system will void this Warranty.

2) The factory-built fireplace system manufactured by Superior Fireplace Company (Superior Fireplace System) is subjected to normal use including burning such natural fireplace fuels as wood and natural or LP gas. Fuel products with abnormal burning characteristics including but not limited to fuels such as coal or plywood and wood products using a binder may burn at excessive temperatures and may cause damage to the fireplace or may cause it to function improperly. Superior Fireplace Company does not warrant this factory-built system when such fuels have been used.

3) Coverage of this Warranty is contingent upon use of an adequate fireplace grate. Superior Fireplace Company is not responsible for damage or injury resulting from failure to use an adequate grate.

4) Superior Fireplace Company is not responsible for inadequate fireplace system drafts caused by air conditioning, heating, mechanical systems or general construction conditions which may generate negative air pressures in the room in which the fireplace is installed. Additionally, Superior Fireplace Company assumes no responsibility for smoking conditions caused by inadequate chimney heights from adjoining trees or buildings, adverse wind conditions or unusual environmental factors and conditions.

## LIMITATIONS ON LIABILITY

IT IS EXPRESSLY AGREED AND UNDERSTOOD THAT SUPERIOR FIREPLACE COMPANY'S SOLE OBLIGATION AND PURCHASER'S EXCLUSIVE REMEDY UNDER THIS WARRANTY, UNDER ANY OTHER WARRANTY, EXPRESSED OR IMPLIED, OR OTHERWISE, SHALL BE LIMITED TO REPLACEMENT, REPAIR, OR REFUND, AS SPECIFIED ABOVE.

IN NO EVENT SHALL SUPERIOR FIREPLACE COMPANY BE RESPONSIBLE FOR ANY INCIDENTAL OR CONSEQUENTIAL DAMAGES CAUSED BY DEFECTS IN ITS PRODUCTS, WHETHER SUCH DAMAGE OCCURS OR IS DISCOVERED BEFORE OR AFTER REPLACEMENT OR REPAIR AND WHETHER OR NOT SUCH DAMAGES IS CAUSED BY SUPERIOR FIREPLACE COMPANY'S NEGLIGENCE. SOME STATES DO NOT ALLOW THE EXCLUSION OR LIMITATION OF INCIDENTAL OR CONSEQUENTIAL DAMAGES, SO THE ABOVE LIMITATION OR EXCLUSION MAY NOT APPLY TO YOU. THE DURATION OF ANY IMPLIED WARRANTY WITH RESPECT TO THIS SUPERIOR FIREPLACE IS LIMITED TO THE DURATION OF THE FOREGOING WARRANTY. SOME STATES DO NOT ALLOW LIMITATIONS ON HOW LONG AN IMPLIED WARRANTY LASTS, SO THE ABOVE MAY NOT APPLY TO YOU.

## INVESTIGATION OF CLAIMS AGAINST WARRANTY

Superior Fireplace Company reserves the right to investigate any and all claims against this Warranty and to decide upon method of settlement.

## SUPERIOR FIREPLACE COMPANY NOT RESPONSIBLE FOR WORK DONE WITHOUT WRITTEN CONSENT

Superior Fireplace Company shall in no event be responsible for any warranty work done without first obtaining Superior's written consent.

## DEALERS HAVE NO AUTHORITY TO ALTER THIS WARRANTY

Superior Fireplace Company's employees and dealers have no authority to make any warranties nor to authorize any remedies in addition to or inconsistent with those stated above.

## HOW TO REGISTER A CLAIM AGAINST WARRANTY

In order for any claim under this Warranty to be valid, Superior Fireplace Company must be notified of the claimed defect in writing or by telephone to Superior Fireplace Company, attention Customer Service Department, 4325 Artesia Avenue, Fullerton, California 92633, telephone 714-521-7302 as soon as reasonably possible after the defect is discovered. Claims against this Warranty in writing should include the date of installation, and a description of the defect.

## OTHER RIGHTS

This Warranty gives you specific rights. This and you may have other rights which vary from state to state.

Superior reserves the right to make changes at any time, without notice, in design, materials, specifications, prices and also to discontinue colors, styles and products.

Distributed by:

**SUPERIOR**  
The Fireplace Company  
A MOBEX Subsidiary

Printed in U.S.A.  
© 1986 by Superior Fireplace Company  
P/N 092827 REV. B 6/86

4325 Artesia Avenue  
Fullerton, CA 92633

Plants in Fullerton, CA,  
Union City, TN

### Installation Instructions

*For Superior  
Glass Doors  
Models  
28GD, 38GD, 43GD  
28GD-AB, 33GD-AB  
38GD-AB, 43GD-AB*

This installation and operation manual will help you obtain a safe and dependable installation for your Glass Door Assembly. Please read and understand these installation and operating instructions before beginning your installation and before starting your first fire.

Do not attempt to modify or alter the construction of these door assemblies. Any modification or alteration may void the warranty listings and approvals of these systems.

### GENERAL INFORMATION

Before starting the installation of this glass door kit, make a careful inspection of all parts to ensure they are undamaged and complete. Refer to illustration to identify all necessary parts.

**CAUTION: SUPERIOR GLASS DOORS ARE UL LISTED FOR USE ONLY WITH CERTAIN FACTORY-BUILT FIREPLACE SYSTEMS MANUFACTURED BY SUPERIOR FIREPLACE COMPANY. USE ON ANY OTHER FIREPLACE MAY CONSTITUTE A POTENTIAL FIRE HAZARD. REFER TO SPECIFIC FIREPLACE INSTALLATION INSTRUCTIONS TO IDENTIFY APPROPRIATE GLASS DOOR MODELS THAT CAN BE USED.**

**PLEASE RETAIN THIS  
MANUAL FOR FUTURE  
REFERENCE.**

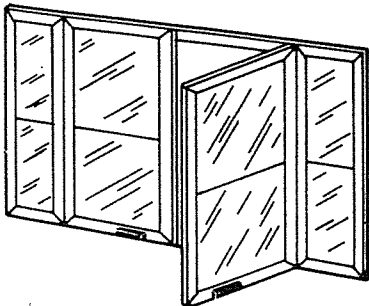



## TOOLS REQUIRED

- small or medium phillips screwdriver

## PRELIMINARY INSTRUCTIONS

**Step 1:** Remove and save the 8 sheet metal screws from inside the fireplace frame (as illustrated, and which coincide with hole locations on glass door frame assemblies).

**Step 2:** Certain fireplaces are shipped with a screen rod cover that is removed at this time. Loosen remaining screws on top and top sides, screen rod cover can now be detached from the fireplace. Do not re-install with glass door assembly; the cover may be discarded. Omit Step 2 if fireplace model has no screen rod cover.

**Step 3:** Attach the wood handles with the wood screws provided in the hardware kit (two per handle). **CAUTION: DO NOT OVERTIGHTEN.**

## INSTALLATION

**Step 1:** Position entire glass door assembly in the fireplace frame with the wood handles on bottom.

**Step 2:** Secure the glass door assembly to the fireplace frame with the 8 sheet metal screws previously removed.

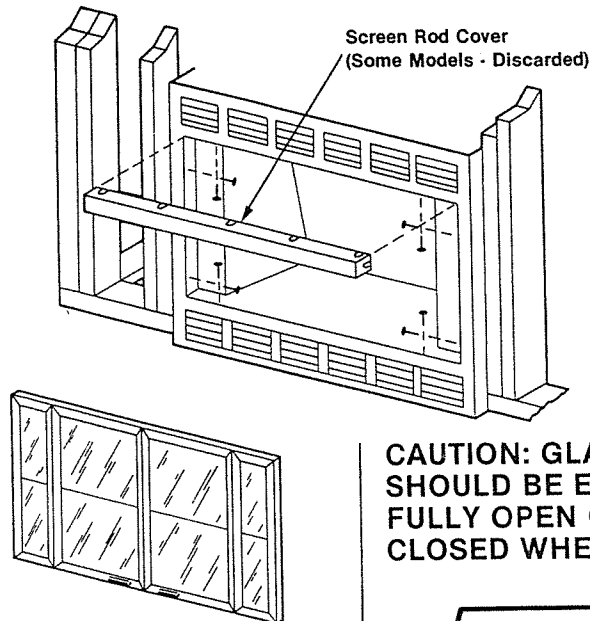

## OPERATING PRECAUTIONS AND INSTRUCTIONS

- Never allow wood or other fuel to rest against the doors while burning.
- The fire grate should be at least 3 inches away from the glass doors.
- Use fireplace tools carefully to avoid striking the glass panels.
- Never clean glass doors while they are hot.
- Never slam or force the doors as a bent frame could cause the glass to break as it heats up.

**CAUTION: GLASS DOORS SHOULD BE EITHER FULLY OPEN OR FULLY CLOSED WHEN BURNING.**

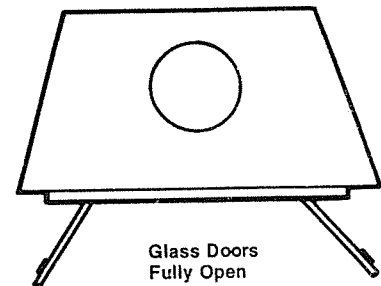

- Keep damper open until fire is completely out and all burning has stopped.
- Keep glass doors closed at night when retiring to minimize loss of heated room air from escaping up chimney.

**CAUTION: GLASS AND METAL FRAMES GET HOT - ALWAYS USE WOOD HANDLES TO OPEN AND CLOSE DOORS.**

Distributed by:

**SUPERIOR**  
The Fireplace Company  
Division of MOBEX Corporation

4325 Artesia Avenue  
Fullerton, CA 92633

Plants in Fullerton, CA  
Union City, TN

# Glass Door Limited Warranty

## The Warranty

Superior Fireplace Company warrants this Glass Door to be free from defects in materials and workmanship at the time of manufacture for a period of 90 days from the date of installation. If the Glass Door covered by this Warranty is found to be defective (see Superior's right of investigation outlined below), Superior will at its option repair or replace the Glass Door in accordance with the following schedule:

- (1) During the 90 day term of the Warranty, Superior Fireplace Company will provide at no charge replacement glass panes should the glass panes be broken resulting from defects in materials and workmanship but will assume no responsibility for labor costs. Superior Fireplace Company is not responsible for accidental breakage caused by impact incurred in transit, handling or operation either before, during or after installation.

## Notification of Remedy

If Superior Fireplace Company finds the Glass Doors to be defective under the provisions of this Warranty; the Company will then, in writing, so notify the fireplace system purchaser of which option (replacement or repair) Superior has elected to pursue. Written notice shall be signed by a responsible officer of the Company. No other form of advice regarding Superior Fireplace Company's election of option is authorized or binding upon the Company.

## Qualifications to the Warranty

The complete Glass Door Warranty outlined above is further subject to the following qualifications:

- (1) The Superior Glass Door must be installed in accordance with Superior Fireplace Company Installation Instructions and local building codes. Certain portions of the Superior Glass Door were not manufactured by the Superior Fireplace Company but were supplied to Superior Fireplace by other manufacturers. Except as provided, Superior Fireplace is not responsible for, and this warranty does not cover, the products of other manufacturers and any loss or injury caused by or resulting from a defect in those products.
- (2) The Superior Glass Door must be subjected to normal use including burning such natural fireplace fuels as wood and natural or LP gas. Fuel products with abnormal burning characteristics, including but not limited to fuels such as coal or plywood and other wood products using a binder, may burn at excessive temperatures and may cause damage to the Glass Door or may cause it to function improperly. Superior Fireplace Company does not warrant this Superior Glass Door when such fuels have been used.
- (3) Coverage of this Warranty is conditioned upon use of an adequate fireplace grate. Superior Fireplace Company is not responsible for damage or injury resulting from failure to use an adequate grate.

## Limitation of the Liability

It is expressly agreed and understood that Superior Fireplace Company's sole obligation and purchaser's exclusive remedy under this warranty, under any other warranty, expressed or implied, or otherwise, shall be limited to replacement or repair as specified above.

IN NO EVENT SHALL SUPERIOR FIREPLACE COMPANY BE RESPONSIBLE FOR AN INCIDENTAL OR CONSEQUENTIAL DAMAGES CAUSED BY DEFECTS IN ITS GLASS DOOR, WHETHER SUCH DAMAGE OCCURS OR IS DISCOVERED BEFORE OR AFTER REPLACEMENT OR REPAIR, AND WHETHER OR NOT SUCH DAMAGE IS CAUSED BY SUPERIOR FIREPLACE COMPANY'S NEGLIGENCE. Some States do not allow the exclusion or limitation of incidental or consequential damages, so the above limitation or exclusion may not apply to you. THE DURATION OF ANY IMPLIED WARRANTY APPLICABLE TO GLASS DOOR IS LIMITED TO THE DURATION OF THE FOREGOING WARRANTY. Some States do not allow limitation on how long an implied warranty lasts, so the above may not apply to you.

## Investigating Claims Against Warranty

Superior Fireplace Company reserves the right to investigate any and all claims against this Warranty and at its sole discretion to decide upon method of settlement.

## Superior Fireplace Company Not Responsible for Work Done Without Written Consent

Superior Fireplace Company shall in no event be responsible for any Warranty work done without first obtaining Superior's written consent.

## Dealers Have No Authority to Alter this Warranty

Superior Fireplace Company's employees and dealers have no authority to make any warranty nor to authorize any remedies in addition to or inconsistent with those stated above.

## How to Register a Claim Against Warranty

In order for any claim under this Warranty to be valid, Superior Fireplace Company must be notified of the claimed defect in writing or by telephone to Superior Fireplace Company, attention Customer Service Department, 4325 Artesia Avenue, Fullerton, California 92633, Telephone: 714-521-7302, as soon as reasonably possible after the defect is discovered. Claims against this Warranty made in writing should include the date of installation, and a description of the defect.

## Implied Warranty Rights

This Warranty gives you specific legal rights. You also have implied warranty rights. In the event of a problem with warranty service or performance, you may be able to go to a small claims court, a State court, or a Federal district court.

Distributed by:

**SUPERIOR**  
The Fireplace Company  
Division of MOBEX Corporation

4325 Artesia Avenue  
Fullerton, CA 92633

Plants in Fullerton, CA  
Union City, TN