

**INSTALLATION AND MAINTENANCE MANUAL**  
**FOR AFF FIRE SUPPRESSION SYSTEMS**



## **TABLE OF CONTENTS**

<b><u>CONDITIONS OF USE</u></b>	P- 3
<b><u>SYMBOLS AND ABBREVIATIONS</u></b>	P- 3
<b>1) <u>REFERENCES</u></b>	P- 4
<b>2) <u>PLANNING THE INSTALLATION</u></b>	P- 5
<b>3) <u>INSTALLATION STEP BY STEP</u></b>	P- 10
3.1 CUSTOMER COMMUNICATION	
3.2 MAIN AGENT CYLINDER AND BRACKET	
3.3 FIXING THE CYLINDER BRACKET	
3.4 AUTOMATIC LOP VALVE	
3.5 SIPHON HOSES AND TUBES	
3.6 FILLING AND PRESSURISING CYLINDERS	
3.7 FITTING THE FOAM PIPE AND NOZZLE SYSTEM	
3.8 REMOTE ACTUATORS	
<b>4) <u>FIRE DETECTION AND ALARMS</u></b>	P-26
<b>5) <u>SYSTEM COMMISSIONING AND CERTIFICATION.</u></b>	P-53
<b><u>APPENDIX A</u></b> – HYBRID SCHEMATIC CONCEPT – CONTROL PANEL TYPE ALARM.	
<b><u>APPENDIX B</u></b> – ELECTRIC SCHEMATIC CONCEPT – CONTROL PANEL TYPE ALARM.	
<b><u>APPENDIX C</u></b> – PNEUMATIC SCHEMATIC CONCEPT – INDICATING PANEL TYPE ALARM.	
<b><u>APPENDIX D</u></b> – COMMISSIONING REPORT	
<b><u>APPENDIX E</u></b> – CERTIFICATE OF COMPLETION	
<b><u>APPENDIX F</u></b> – SERVICE INSPECTION SCHEDULE	
<b><u>APPENDIX G</u></b> – TESTING SCHEDULE	
<b><u>APPENDIX H</u></b> – PREVENTIVE MAINTENANCE SCHEDULE	
<b><u>APPENDIX I</u></b> – SURVEY SCHEDULE	
<b>6) <u>COMPONENT COMPLIANCE.</u></b>	P- 68
<b>7) <u>ADDENDUM – ISSUE RECORDS &amp; AMENDMENTS</u></b>	P- 70

## CONDITIONS OF USE OF THIS MANUAL

PT Indonesian Fire Equipment systems is further abbreviated in this manual as IFES. The objective of this manual is to provide customers, designers, installers and maintenance personnel with clear information about the installation and maintenance of fire suppression systems as fitted by IFES.

This document is subject to continuous development. The information contained within is supported by the Technical Department of IFES and was correct at the time of printing. The Technical Department reserve the right to delete, alter or add to the contents herein without notice and prior indication. (Errors and Omissions Excepted – E&OE)

Please contact IFES to advise of any anomalies or requests for further information.

## SYMBOLS USED IN THIS MANUAL



**DANGER:** Indicates a specific danger to personnel or equipment that requires risk management.



**WARNING:** Indicates caution is needed in this area. Take particular note of instructions and warnings.



**NOTICE:** Indicates a particularly important piece of information to take note of.



A quick tip is useful information that gives the technician advice on how to make an activity easier to do, or complete.

## ABBREVIATIONS USED IN THIS MANUAL

**AS (number)** a number preceded by “AS” indicates “Australian Standard”. If it is accompanied by a date then that particular publication applies. If no date is quoted it is presumed that the most current publication is in use.

**IFES** Abbreviation for PT Indonesian Fire Equipment systems. A company registered in Balikpapan – Indonesia.

**WRAC** The acronym describing the risk management system used by IFES

## 1) REFERENCED STANDARDS

The following is an abbreviated standards reference list used to support this product. For a comprehensive reference list, see Appendix A AS 5062-2006.

AS 5062 – 2006 Fire protection for mobile and transportable equipment

AS 1210 Pressure vessels

AS 1851 Maintenance of fire protection systems and equipment

AS 2030 The verification, filling, inspection, testing and maintenance of cylinders for storage and transport of compressed gasses.

AS 2030.1 Part 1: Cylinders for compressed gases other than acetylene

AS2470 Steel cylinders for compressed gases—Welded three-piece construction with longitudinal joint—11 kg to 150 kg

AS 2613 Safety devices for gas cylinders

AS 3791 Hydraulic hose

(see also MSHA 2G USA Bureau of Mines, Schedule 2G, March 19, 1968)

AS 4024 Safety of machinery

AS 4024.1301 Part 1301: Risk assessment—Principles of risk assessment

AS 4024.1302 Part 1302: Risk assessment—Reduction of risks to health and safety from hazardous substances emitted by machinery—Principles and specification for machinery manufacturers

AS 4024.1603 Part 1603: Design of controls, interlocks and guards—Prevention of unexpected start-up

AS 1841 Portable fire extinguishers

AS 1841.1 Part 1: General requirements

AS 1850 Portable fire extinguishers—Classification, rating and performance testing

AS 4360 Risk management



## 2) PLANNING THE INSTALLATION

The installation of an IFES fire suppression system is done in conjunction with the following documents.

- A) **DESIGN DOCUMENTS.** A trained and accredited designer will use the approved design software to prepare the following documents
- **Risk Reduction Plan.** This is important to the installer. The designer and a risk management committee have reviewed the unacceptable risks. The fire suppression system to be installed is to make these particular risks acceptable. Read the risk reduction plan and note any specific comments that will assist to install an effective system. In particular fuel and ignition sources.

**Figure below** – example extract from design software showing the WRAC risk management principle.

### RISK MANAGEMENT PLAN

For: **Haul Truck 150 Tonne**

Please note, the chart below is used under the Workplace Risk Assessment and Control (WRAC) procedure by IFES to rate risk by Likelihood versus Consequence. The following process rates identified inherent risk and the risk management committee makes decisions on risk reduction action to bring unacceptable risks to acceptable levels.

Risk can be reduced by lowering either likelihood or consequence.

Likelihood	Consequence				
	1 - Minor	2 - Medium	3 - Serious	4 - Major	5 - Catastrophic
A - Almost / Certain	Moderate	High	Critical	Critical	Critical
B - Likely	Moderate	High	High	Critical	Critical
C - Possible	Low	Moderate	High	Critical	Critical
D - Unlikely	Low	Low	Moderate	High	Critical
E - Rare	Low	Low	Moderate	High	High

#### DEFINITION OF RISK RATINGS

**CRITICAL:** A CRITICAL RISK demands close attention to the risk reduction plan to achieve a residual risk rating of preferably LOW rating. A residual CRITICAL risk rating would be Unacceptable to proceed in this activity or process under any circumstance.

**HIGH:** A HIGH RISK demands close attention to the risk reduction plan to achieve a residual risk rating of preferably LOW rating. A residual HIGH risk rating would make this activity or process extremely unlikely as an acceptable process to proceed with.

**MODERATE:** A MODERATE RISK demands attention to the risk reduction plan to achieve a residual risk rating of preferably LOW rating. A residual MODERATE risk rating would make this activity or process extremely undesirable but possibly acceptable if a low risk is not achievable. If this risk is accepted, it needs constant supervision and effort to control the risk and continue to seek risk reduction alternatives.

**LOW:** A LOW RISK indicates that the inherent risk is already acceptable and may not require risk Reduction activities. This does not preclude however, that further risk reduction should not be considered.

**Figure below** – example extract from the IFES design software showing the WRAC risk reduction control outlining the fire protection system objectives.

**STEP 3) CAN RISK BE REDUCED BY BETTER ADMINISTRATIVE CONTROLS?**  
**ACTION:-**  
Maintenance department will implement a planned replacement of the turbo lubrication lines every two years. This has been identified as a known cause of fire after fatigue failures.

**REVIEW RISK AGAINST REDUCED LIKELIHOOD OR REDUCED CONSEQUENCE**

LIKELIHOOD : POSSIBLE  
CONSEQUENCE : CATASTROPHIC

REVISED RISK RATING : **CRITICAL**

**STEP 4) CAN RISK BE REDUCED BY IMPROVING FIRE PROTECTION MEASURES?**  
**ACTION:-**  
machine have been usually caused by Diesel fuel or lubrication oil coming into contact with the turbo charger. Foam suppression needs to provide a strong average spray at at least 4.5 LPM/minr for a discharge time of nominally one minute. Ensure the spray overlap occurs over the turbos to maximise cooling effect.

**MAINTENANCE CONSIDERATIONS FOR FIRE EQUIPMENT**  
Schedule 11.1 AS5062 is considered too long between inspections at 6 months. For this machine, the 6 monthly scheduled procedures shall be carried out at alternated PM services as scheduled by the main

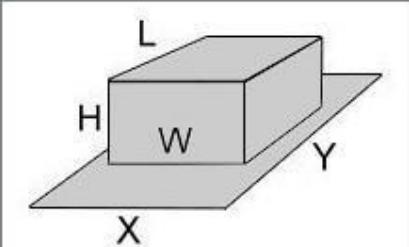
**REVIEW RISK AGAINST REDUCED LIKELIHOOD OR REDUCED CONSEQUENCE**

LIKELIHOOD : POSSIBLE  
CONSEQUENCE : MINOR

REVISED RISK RATING : **LOW**

B) **Design Summary.** The design program will also print a DESIGN SUMMARY. This defines the key specifications from the critical calculations involving foam quantity, nozzle quantity, anticipated discharge time and the resulting foam application rate. See example following.

FIRE RISK AREA DIMENSIONS



LENGTH L =  METRES

WIDTH W =  METRES PRISM METHOD  
- RULE NO 1.1 -

HEIGHT H =  METRES

DIRECT AREA =  SQR METRES

INDIRECT AREA IF APPLICABLE (METRES) - RULE NO 1.2 -

X  =  SQR METRES

FIRE DETECTION

Loss of Pressure (LOP)
  Rise of Pressure (ROP)
  Fire Detection Wire (FW)

DESIGNERS SELECTIONS

TOTAL DIRECT AREA =  SQR M

TOTAL NOZZLES SELECTED =

ESTIMATED DISCHARGE TIME =  SECONDS

ESTIMATED FLOW - 50SECS =  LITRES

MAX DIRECT AREA =  SQ MTRS AT 4.1 LPM/SQ MTRS/MIN PASS

MAX INDIRECT AREA =  SQ MTRS AT 12 LPM/SQ MTRS/MIN PASS

TOTAL INDIRECT AREA =  SQR M

NOZZLE FOAM CONSTANT (K:35) =  Bar (Pn aV)

SELECT CYLINDER =  QTY =  Av Flow =  LITRES / MIN

In this example the designer has called up a design requiring the installation of 12 spray nozzles, and a foam quantity of 50 litres with a discharge time estimated of 78 seconds.

## NOTICE

DISCHARGE TIME. In the fire test simulator, it can be demonstrated that there are two key considerations for effective suppression and extinguishment. Firstly there must be enough foam solution and secondly it must be applied fast enough to defeat the fire. IFES design flow rates are carefully calculated after being researched on the IFES fire simulator. The first 50 seconds are considered the most critical to achieve the application rates designed for.

In practical terms it is important not to apply the foam agent too slowly. The allowable tolerance on discharge time is minus 10% of minimum time and plus 10% on target time. In the example shown above; the minimum allowed for is 60 seconds, and a test tolerance of 10% applies. The system would pass the discharge test if it discharged within 78 + or – 10% = 70 to 85 seconds.

**C) Pipework calculations.** The designer, using the program will verify pipe allowances which include the hose and tubing used to carry the foam solution to the nozzles. There are two key areas:-

**RULE 5.1** The maximum flow velocity through any point on the hydraulic system shall not exceed 6 metres per second based on nominal bore size and shall not exceed 9 metres per second based on minimum fitting orifice size.

**RULE 5.2** The pipe work design shall not have an internal volume of more than 6% of the agent volume stored in the cylinder(s) supplying it.

In the example below, for RULE 5.1; the designer has nominated the sizes and quantities of pipe estimated for the job. The nominal bore velocities are all close to 6 metres per second. None of the orifice velocities are close to the 9 metre per second. As long as no changes are made in the number of nozzles to be used, there is no concern for the installer as this is just a calculation against flow rate that has verified a pass to design rules.

Rule 5.2 deals with the amount of pipe used. The current pipework volume is calculated at 2.1 litres which is well below the limit of 5.7.



**CAUTION** -If the quantity of pipe used is significantly above the original estimate, the installer should ask the designer to recalculate and verify.

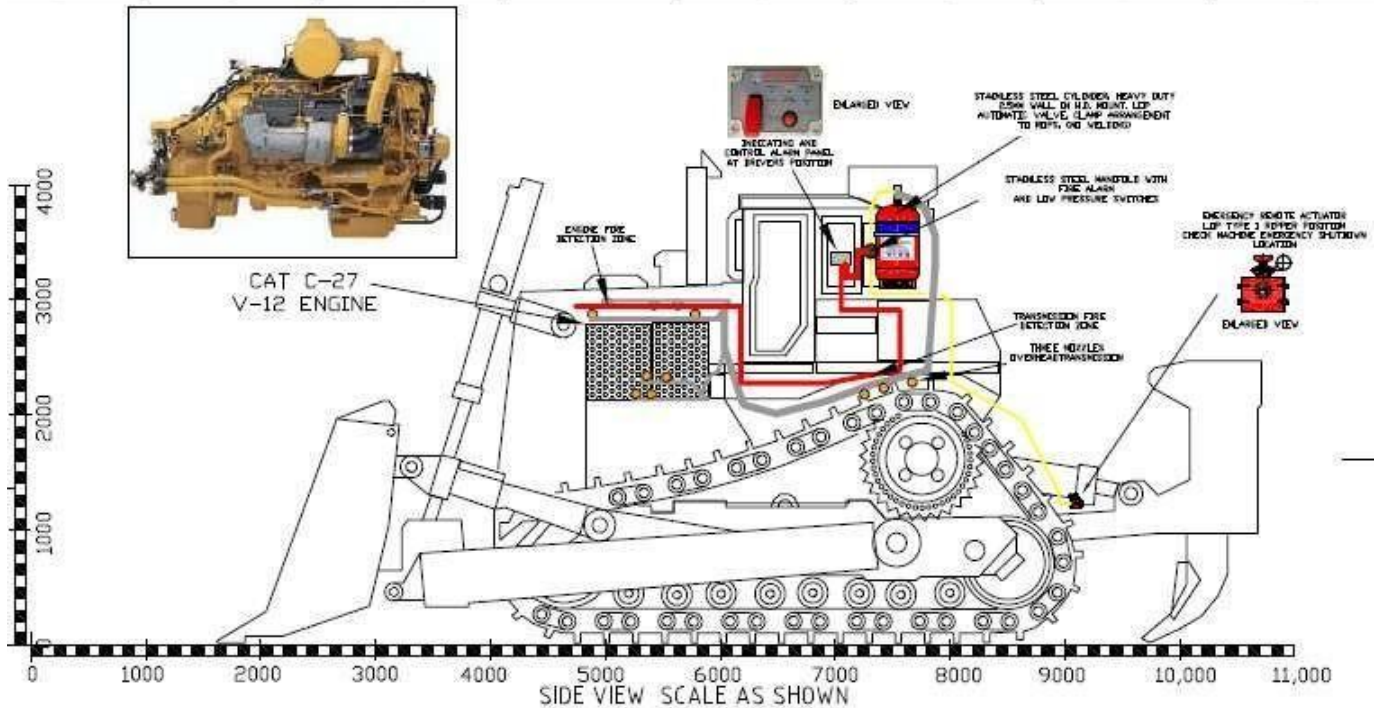
Pipe Type	Length (M)	Nom Bore (mm)	Min Orifice (mm)	No of Nozzle	Nom Bore Velocity (M/s)	Min Orifice Velocity (M/s)	Check
20mm Hose	4	19.0	16.0	20	3.6	5.1	PASS
12mm Tube	7	10.5	10.5	10	5.9	5.9	PASS
12mm Hose	4	10.0	9.0	4	2.6	3.2	PASS
	0	0.0	0.0	0	0.0	0.0	PASS
	0	0.0	0.0	0	0.0	0.0	PASS
	0	0.0	0.0	0	0.0	0.0	PASS

Total Volume Pipework : 2.1 L  
6% of Total Solution : 5.7 L



D) **Drawings and “As Installed photos”** - Australian Standard AS 5062 -2006 states in Chapter 6.2 that there shall be general arrangement drawings showing the layout of the system and detailing the location of all major components.

Below is an example of a drawing that meets this requirement.



## NOTICE

Photographs of the components after being successfully installed form a very important part of the installation records. These compliment the general arrangement drawings and aid other technicians doing similar installations and maintenance activities. Photos are easy to organise and are mandatory to the installation rules herein.

### 3) INSTALLATION STEP BY STEP

#### 3.1 CUSTOMER COMMUNICATION

When preparing for the installation of an IFES fire suppression system, the customer's representative who will ultimately approve the installation and receive the certificate of completion should have prior knowledge of and give approval to your installation plan. Critical aspects to agree on BEFORE STARTING are the location of key equipment such as cylinder and bracket, alarm and remote actuation points. This will help avoid disputes and re-work when your plan is not what the customer wants or prefers.

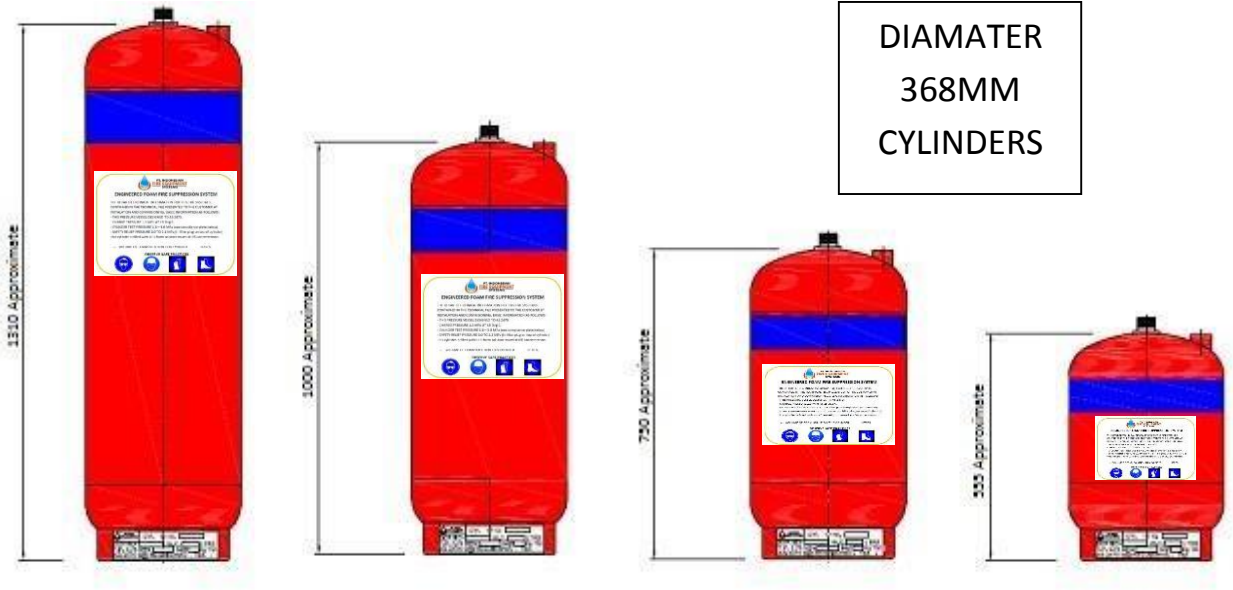
**3.2 MAIN AGENT CYLINDER AND BRACKET.** This is usually the first consideration as it is the largest component and therefore the most challenging to find a suitable location for. This is where knowledge of the machines and experience help dramatically. Often an install will be a repeat the same or similar installations done before. Refer to previous installation drawings and photographs and verify with the customer before proceeding. Installations that are consistently the same high quality give the customer confidence while inconsistency will create a poor reputation and lack of confidence from the customer. In a first of kind installation, more time is needed with the er and the designer to survey the machine carefully and develop a plan.



**CAUTION** - You should verify with the customer and machine OEM that the area you are installing the cylinder is strong enough to support the gross weight considering the activity of the machine. The OEM may have to reinforce the bracket location. Some machines may need special attachments made. For example large bulldozers often have the cylinder bracket mounted to the Roll Over Protection (ROPS) frame. These usually have restrictions preventing welding on ROPS. A special attachment may need to be designed and made. See specification chart next page for installed mass.

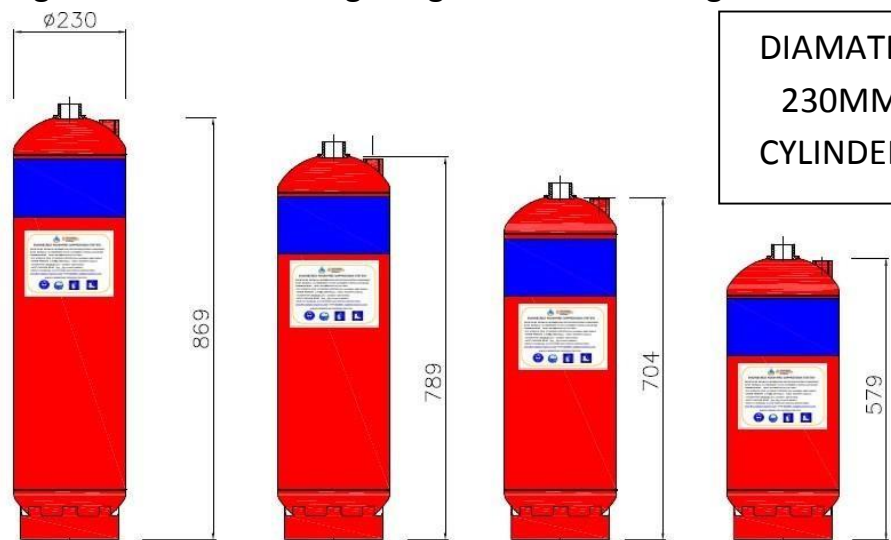


Figure shows a 120 Litre cylinder in a bracket and bracket and cylinder separately.



**DIAMETER  
368MM  
CYLINDERS**

120 Litre PART NO.1.10.120. Mass Empty 31 Kg	90 Litre B1.10.090. 24 Kg19 Kg	65 Litre B1.10.065. 15 Kg	45 Litre B1.10.045.B
--	--------------------------------------	---------------------------------	-------------------------



**DIAMETER  
230MM  
CYLINDERS**

*32 Litre PART NO. 1.10.032. Mass Empty10.3 Kg	28 Litre 1.10.028. 10.0Kg	*25 Litre 1.10.025. 9.8Kg	*20 Litre 1.10.020.B 9.6 Kg
--	---------------------------------	---------------------------------	-----------------------------------

\* Non preferred size. Check availability before specifying or order for manufacture.

## FOAM AGENT CYLINDERS – GENERAL SPECIFICATIONS

### PRESSURE RATINGS -

TEST PRESSURE	- 3.0 MPa Hydrostatically tested at manufacture.
MAX SAFE PRESSURE	- 2.0 MPa When following AS 2030 procedures.
NORMAL CHARGE PRESSURE	- 1.37 MPa As directed in this manual.

PAINTING. Powder coated Signal Red with Blue band identifying them under AS-5062 as a foam agent cylinder.

FITTINGS.- Main Neck Ring 1¼” BSP Male  
- Filler Port 1¼” BSP Female.

LABEL . Identification and instruction label supplied standard with cylinders.

AS2470 Compliance. Refer to compliance plate on foot-ring. This contains required safety information including date of manufacture, serial number and test pressure.

DESIGN REGISTRATION – The cylinder design is registered with the Australian Government under New South Wales WorkCover registration Certificates.

GC 6-174641/13. For 368mm Cylinders,

GC 6-196717/15 for 230mm cylinders.



### 3.3 FIXING THE CYLINDER BRACKET

In the base of the bracket there are 4 x 34mm diameter holes. These are to allow the fitment of the vibration eliminator arrangement and weld mounts. The vibration eliminator and weld mount are supplied in a kit form Part- 1.30.004 or the individual components can be purchased separately. See Product manual for details

Exploded view of vibration eliminator and weld mount arrangement



A side view that shows the assembled vibration eliminator assembly. The red line represents the base plate of the bracket.



These can be temporarily assembled on the base of the bracket, tack weld the weld mounts into position, remove the bracket and fully weld with a 3 mm bead.

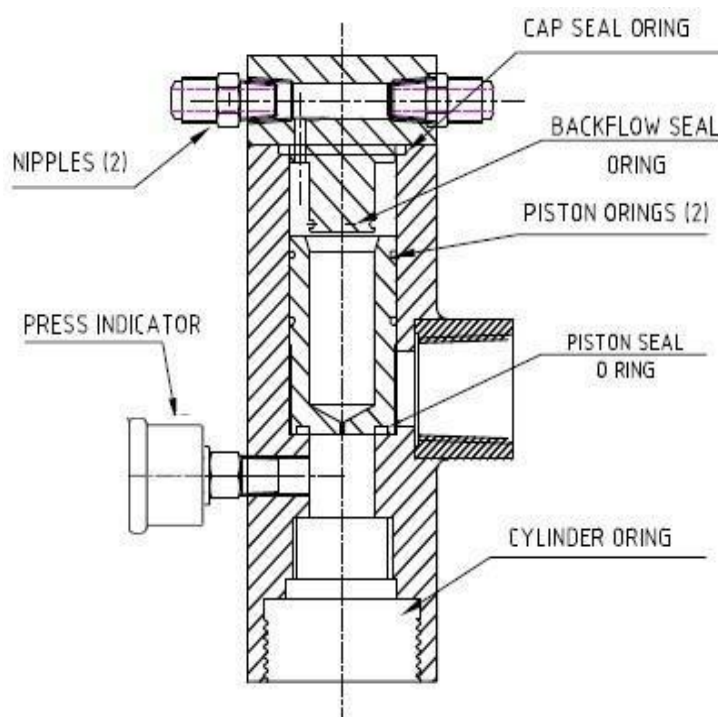


This photo shows the front vibration eliminators in position and the weld mounts below with the cylinder strapped in. Note the cylinder compliance plate stamping on the foot ring. It is always good practice to leave this in a visible position for service inspections during maintenance.

After welding, good tradesman-ship would require the mild steel weld mounts to be “touch up” painted. Talk to the OEM, they will probably have matching paint for this or can arrange for their painter to assist!

### 3.4 AUTOMATIC LOP VALVE

The automatic valve works on a loss of pressure principle that is often used in this field of fire protection. The body and cap are all stainless steel while the piston is made of brass. When the pneumatic fire detection and actuation circuit is connected to the cap via one or more nipples, the valve will charge the cylinder through the piston orifice and the pressure will remain equal. If fire is detected or a manual actuator is used, the pressure above the piston is released. This will cause the piston to rise and discharge will occur through the 3/4" BSP side port. The lower section of the valve is threaded 1 1/4" BSP to match IFES cylinders and there is a lower internal 3/4" BSP to allow fitment of the siphon hose assembly.



**AUTOMATIC LOP VALVE PART 2.10.001  
SHOWN IN CROSS SECTION AND EXPLODED PHOTO**

### 3.5 SIPHON HOSES AND TUBES.

The part manual offers two types of siphon hose arrangement. Most cylinders are installed vertically and a rigid type is recommended. This suits installations to within 45 degrees of vertical. Cylinders may be installed within 10 – 45 degrees from horizontal, in these cases a flexible pick up hose must be used.

### 3.6 FILLING AND PRESSURISING CYLINDERS

#### AGENT

IFES Aqueous Film Forming Foam (AFFF) is supplied as a concentrated chemical in containers as per the list below. It is mixed at 9% with water. Please note that AS5062 requires that only potable standard water is used. The agent storage cylinders are made from Stainless Steel and are resistant to corrosion with potable water mixed with agent.

AGENT PART NO	SIZE (L)
6.10.007	20.0
6.10.005	5.0
6.10.003	2.0
6.10.002	1.5
6.10.001	1.0

It is pre mixed in the cylinder with the following fill ratios

CYLINDER VOLUME	ULLAGE VOLUME	SOLUTION VOLUME	POTABLE WATER	9% FOAM CONCENT
120	28	92	83.7	8.3
90	21	69	62.7	6.3
65	15	50	45.5	4.5
45	10	35	31.8	3.2
32*	6	26	23.7	2.3
28	5	23	20.9	2.1
25*	4.8	20.2	18.4	1.8
20*	3.5	16.5	15.0	1.5

\* Non preferred size. Check for availability before specifying.

All amounts shown are in Litres. Fill tolerance is 2% for water and -0% to +2% for foam agent. For variation to these fill ratios, contact IFES for technical support and verification.

## FILLING A NEW CYLINDER



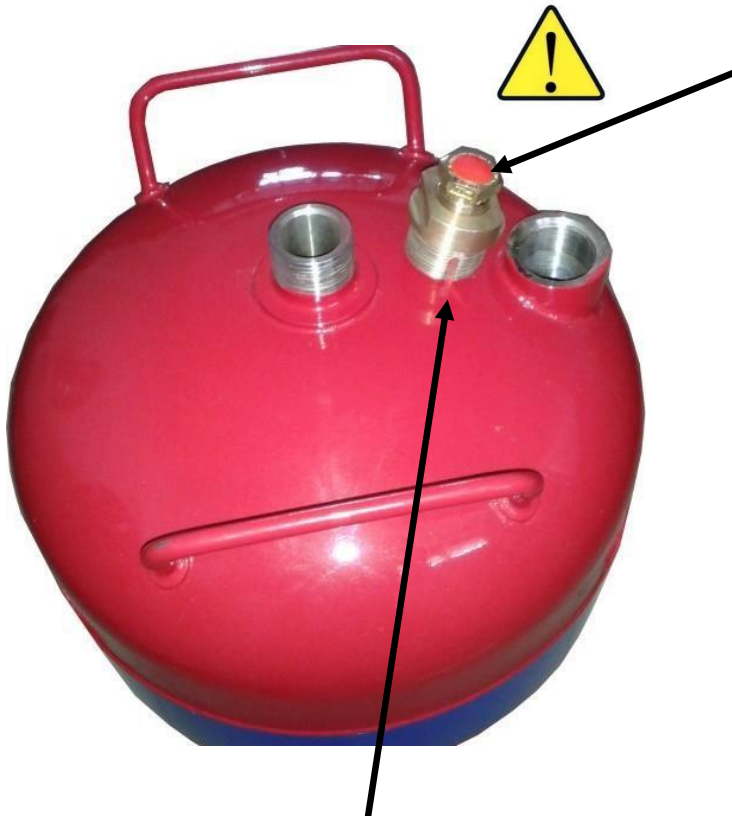
### STEP 1

Unscrew anti-clockwise the valve assembly. Check that the rigid or flexible pick up tube is firmly screwed in. Check the neck ring and O ring seal.



This leaves the neck ring exposed with the filler plug with safety relief on the outer port.





**FILLER RELIEF PLUG.** Note the tamper seal label on top of the SRV. It has a relief pressure at 2700 -3000 KPa. If this is ejected, the cylinder may have been over pressured. Inspect the cylinder to AS2030 procedures and replace the relief filler plug.

### **NOTICE**

Relief filler plugs must be replaced at five years in service to the same inspection period as the agent cylinders

#### STEP 2

Un-tighten and screw out the Filler plug relief assembly. The Safety Relief Valve (SRV) is ½" NPT and should be screwed in tightly with an appropriate sealant. It would not normally be removed from the filler plug, unless the cylinder has been re-tested or it is damaged or leaking.



Sometimes a cylinder may need to be de-pressurised without discharging the agent. Care should be taken to ensure that the cylinder is fully de-pressurised before removing the valve or the relief filler plug.

Note that the filler plug has a relief pressure slot. This ensures that if a technician commences to remove this device under pressure, it will vent. This is a warning that it is still pressurised and you should wait until all discharge has stopped before the device is fully unscrewed.



**DANGER: DO NOT REMOVE THE FILLER PLUG UNTIL VENTING IS COMPLETED.**



- 1) From Jan 2016, Relief filler plugs will change to a ¾" NPT version as shown. Cylinder production will be modified to a ¾" NPT port to match. These SRV's must be replaced at five years in service to the same inspection period as the agent cylinders.



- 2) The main valve will be fitted with a 38mm liquid filled gauge acting as a pressure indicator, with a 1/8" rear entry port. These are supplied without liquid but may be filled with glycerine when installed if severe vibration is expected. The red ranges indicate unacceptable pressures in the too high and too low regions. Green is the acceptable pressure range. ⚠ Yellow is a warning range that indicates too low, but may be considered acceptable until such time as a maintenance can be undertaken.

When filling the stainless steel cylinders, use containers of reliable volume for accuracy on fill ratios. A simple measuring jug is the simplest most reliable way to accurately measure the foam concentrate. This needs to be accurate as 9% is a very fine ratio. Foam concentrate should never be under mixed, but slightly over mixed is not detrimental.



Empty 20L foam containers make good measuring containers to add water.



Always add the water first and the foam last or the cylinder will be difficult to fill due to frothing. Some foams need to be partially mixed before being added – in this case retain a portion of the water, mix and then add the blended foam last.

## **NOTICE**

### **CYLINDER SERVICING**

The stainless steel cylinders shall be maintained in accordance with AS5062-2006 and AS2030.1 . Inspections should be carried out in accordance with AS5062-2006 ref table 11.3 Preventative maintenance. This requires a hydraulic proof test at no longer than 5 year intervals. It is a requirement of the manufacturer that an internal and external inspection in accordance with AS2030.1 be carried out annually. This should be done when the cylinder has been emptied after the discharge test. Pay particular attention to any signs of corrosion and consider note 2 of table 11.3 that states “Cylinders that have been subjected to abusive or abnormal conditions may require hydrostatic pressure testing at greater frequencies”.

## PRESSURISING THE SYSTEM

The agent cylinders after filling and fitment of valve and filler relief plug are pressurised with Nitrogen to 1.375 MPa (1375 KPa). Check the design for the location of the charge valve. This is a 7/16" JIC nipple with non return valve. For most systems the pressurising point is inside the Loss of Pressure remote actuator or in the pressure switch manifold.



**WARNING.** Pressurised gases must be handled by persons competent in the safe use of compressed gases and regulating equipment. Always use cylinders, regulators and procedures that are approved by the safety regulating authority in the country of use.



**DANGER.** There have been known safety incidents where regulated pressures have been used that have over pressurised cylinders to unsafe levels. It is a safety requirement with an IFES system that the nitrogen regulator not be capable of exceeding 2.5MPa (2500 KPa) output. The recommended set pressure during charging should be no more than 1.8MPa (1800 KPa), with care taken to isolate pressure at the charge pressure of 1.375MPa (1375 KPa). If a cylinder has been over pressurised above 2.0 MPa (2000 KPa) but not above 3.0 MPa (3000KPa), the cylinder shall be quarantined and sent to an approved test station for inspection and re-test. If a cylinder has been pressurised above 3.0 MPa (3000 KPa), it must be condemned by procedures defined in AS2030, AS 2337.



Pressure indicators, as shown in the left picture are fitted to the cylinder valve and on the face of remote pneumatic actuators. The centre of the green shows 1350KPa. The calibrated gauge on the regulator should be used to monitor correct pressure. The indicators are indeed indicative only however the red zones



### 3.7 FITTING THE FOAM PIPE & NOZZLE SYSTEM



IFES uses two types of nozzle.

- A) A 60 degree spray type nozzle with dust cap and lanyard is the standard type intended for large machines.
- B) A 100 degree spray type nozzle with dust cap and lanyard is the standard type intended for smaller machines or tight spaces.

Both nozzle types have flow K factor for foam delivery rate calculated by the designer specific to each design. Installers should note that while application rate is calculated in square metres, nozzles deliver in circular or elliptical patterns. The installer must locate nozzles such that overlap, splash effect and run off ensures that no areas are missed. This is to be verified at commissioning by practical observation. The designer will ensure that the discharge time is within 10% of the predicted rate so that the application rate of foam agent achieves the design requirements. So it is important that the nozzle quantity designed for, is installed to give the most even application of foam solution. If the discharge time is more than 10% outside the predicted amount, request the designer to check the performance for compliance.

#### NOZZLE RANGES.

The maximum permissible range shall be such that the foam application rate to the target is as per the designer's application rate and not less than 4.1 litres per square metre per minute for at least 50 seconds. For a single nozzle spraying at 60 degrees the maximum range is 767mm.

The following is a guide

	RANGE TO TARGET IN MM		
	OPTIMUM	MAX	MIN
60 DEGREE NOZZLE -	870	1200	500
120 DEGREE NOZZLE -	300	600	200

Where multiple nozzles are working together this range may be increased to consider the overlapping of spray patterns providing that the average application rate is not decreased.

## PIPE AND NOZZLE ARRANGEMENTS

The pipe work, foam discharge hose and clamps used must conform to the requirements of chapter 8 of AS5062 -2016 . To comply to our rules the hose lines shall also conform to SAE 100R1 OR R2.The design given to the installer will define the risk to be protected and the number of nozzles to be used. It is therefore important to ensure that the nozzle positioning distributes spray within the performance ranges shown in the nozzle performance chart. During commissioning testing, the installer needs to verify that spray is being delivered evenly and that no areas are missed.

The pipe and hose sizes that the designer has nominated must be used to conform to the pipe design rules and checks already discussed earlier in this manual regarding design documentation.

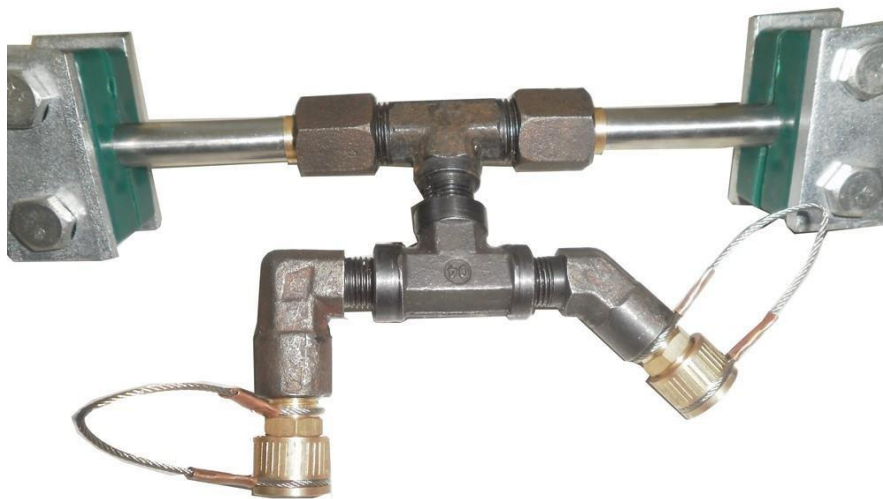


PHOTO SHOWING A DOUBLE NOZZLE ARRANGEMENT  
MOUNTED IN 12.7MM STAINLESS STEEL TUBE USING BOLTED CLAMPS.


Hoses which are wire reinforced such as SAE 100R1 are also very effective,



Based on years of practical experience, a good design and installation plan might use a main feed hose of 19mm NB SAE 100R1 hose to a main tee reducing to a 2 x 12.7mm outlets on a stainless steel ring main. This works well above diesel engines and may use 12mm SAE 100R1 hoses to drop to the sides of large engines. This combination works well as the stainless steel gives excellent heat and fire resistance while the flexible hoses make for easy and neat installation to more difficult areas.

## PIPE AND HOSE MATERIALS

To comply with the design requirements of this manual, pipe and hosing shall comply firstly to all requirements of section 8 in AS 5062-2006. Therefore all hoses shall meet MSHA Schedule 2G flame resistance requirements. IFES supplies and recommends hoses meet SAE100R1, however 100R2 can be used also. In any case the rated working pressure of all hose and pipes shall be at least equal to 2.0 MPa. The hose lines connecting the Loss Of Pressure lines shall be 6MM bore nominally and all fittings made of brass or stainless steel and no orifice in any fitting in the LOP actuation path shall be less then 4mm diameter.

 Warning – If steel fittings are used in the LOP lines, corrosion may occur which will restrict flow and may prevent actuation. Under size fittings have the same effect.



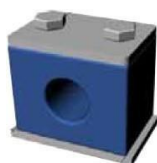
## AREAS THAT MAY BE EXPOSED TO FIRE

All areas that are assessed to be exposed to direct fire in the area identified as the fire risk area should use wire braided type flexible hoses conforming to SAE 100R1 or SAE 100R2 together with compatible couplings. Stainless steel tubing may also be used. See section 6 for compliance requirements of stainless steel tube.

## CLAMPING

The installer must select clamping that will ensure that the system will remain reliable and undamaged considering the conditions the machine works under. Another critical consideration is that the nozzles after positioning, must not move and subsequent service inspections must verify this.

For solid positioning of tube, hoses and nozzles, a bolted clamp is preferred. Those with plastic clamp halves supported by steel bases and cap plates are acceptable. In areas considered to be highly exposed to fire, metal clamp halves should be used. Please note that ceramic material is not approved for use in IFES systems due to problems with cracking. P clamps may be used to support hose in a position but are not considered suitable to hold hose or tube in areas where nozzles are located.





## FINAL PIPEWORK SYSTEM PREPARATION

The orifice hole and the agitating baffle in the body of the nozzle are small and finely machined. They are critical to the performance of the system even a tiny piece of contamination can partially block them making them ineffective or render them totally inoperative.

Therefore it is essential that before installing any hose or pipe while the system is being built, to blow compressed air through them to ensure that foreign material, debris or any other contamination is completely removed.

Furthermore when the system's pipe and hose work is complete but before the nozzles are installed, flush the pipework out with water using a partially filled cylinder and a half charge of nitrogen.

Only when the piping system is perfectly free from contamination are the nozzles fitted. Finally ensure 3 things during nozzle installation:

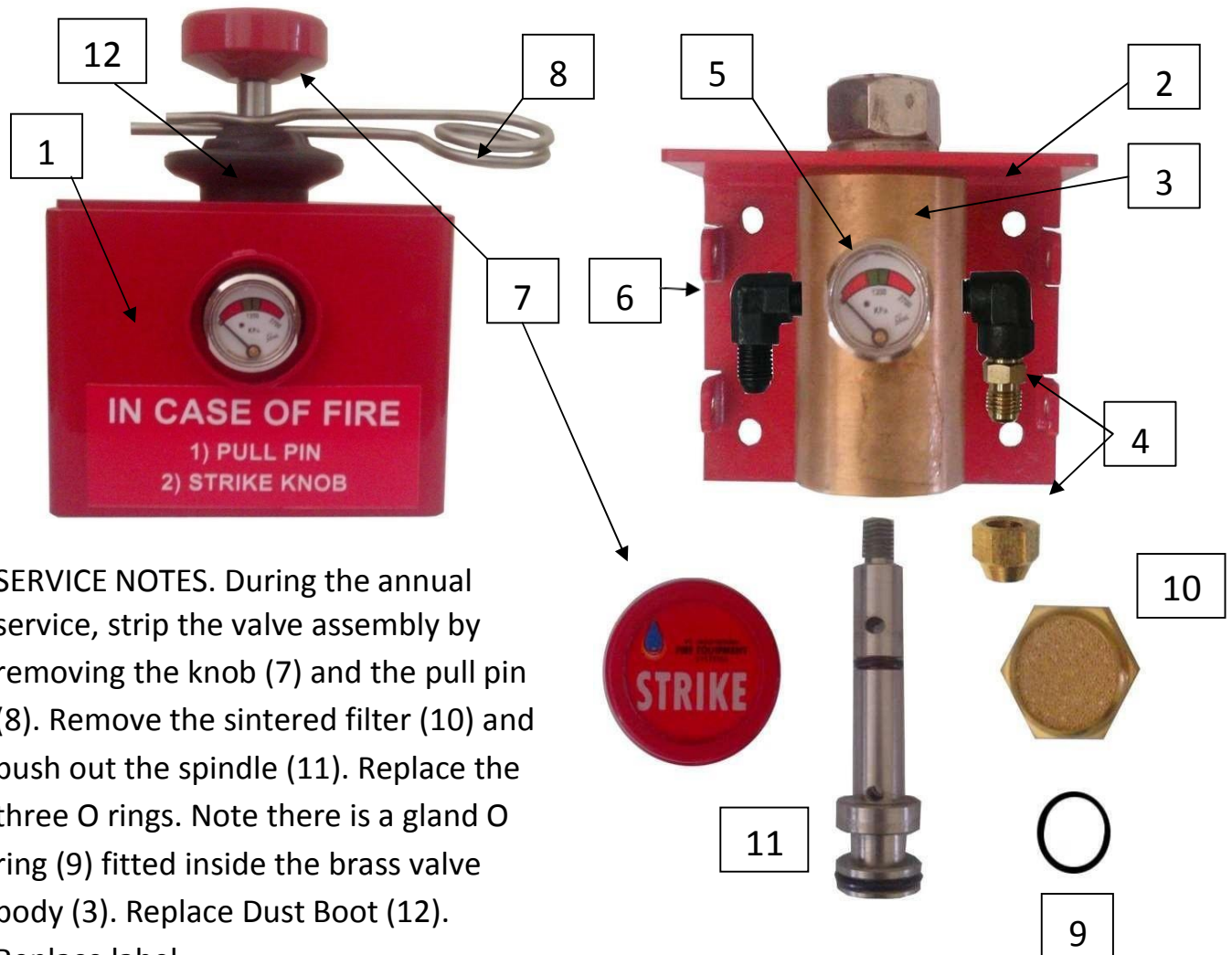
1. The spray type of the nozzle 60° or 120° is correct for that position as defined in the design documents,
2. The orientation of the nozzle is aimed at the target area as defined in the design documents, and
3. When the nozzle "fires" will the cap on the fixed lanyard interrupt the spray pattern and therefore affect performance.
- 4) After any foam discharge, foam solution should be flushed out first with water and then with nitrogen or air. Residual foam solution may have a corrosive effect on plated steel hose and fittings if left for a prolonged period of time.



### 3.8 REMOTE ACTUATORS

The standard Loss Of Pressure (LOP) remote actuator is shown below. It has a stainless steel powder coated mounting and front cover. The pneumatic hose connection enters through the open bottom section. Remove the front cover (1) by unscrewing four x 6mm stainless steel cap screws. The back mounting (2) has four 6.5mm holes available for surface mounting

Connect a 6mm hose from the pneumatic actuation circuit to the 7/16" JIC male elbow (6). There is a brass charge valve (4) fitted. This also is 7/16" male and has a non return seat. A dust cap is provided to keep it protected after charging.



**SERVICE NOTES.** During the annual service, strip the valve assembly by removing the knob (7) and the pull pin (8). Remove the sintered filter (10) and push out the spindle (11). Replace the three O rings. Note there is a gland O ring (9) fitted inside the brass valve body (3). Replace Dust Boot (12).  
Replace label.

Lubricate when assembling and ensure the sintered filter is clean or replaced.

**NOTE:** Electric remote actuation may be fitted when control type alarm panels are used.

#### 4 FIRE DETECTION AND ALARMS

FIRE DETECTION – For systems requiring fire detection, there are two types available for an IFES fire protection system. Both qualify in AS 5062-2006 as “Supervised” detection systems as the loss of pressure fire detection uses a low pressure sender to report fault to the alarm. The Linear detection cable runs a micro-current through the detection line and the End Of Line (EOL) resistor to monitor the integrity of the linear detection cable system.

- A) **Loss Of Pressure (LOP) Detection Tube.** This uses a RED thermoplastic 6mm tube that is connected to the manifold and then through to the LOP valve. See Appendix A and Appendix B. This type of detection directly actuates the release of the foam agent and notifies the alarm via the alarm pressure sender. This type of detection can be used with an indicating alarm panel if there is no electrical actuation. It can also be used with a control panel if it is preferable to electrically manual actuate from the alarm panel even though the detection system directly releases the foam agent.
- B) **Linear detection cable.** IFES linear detection is an internationally recognised UL listed type. This detects a rise in temperature and reports excessive heat (fire) to the Control and indicating alarm. Since this system relies on electrical actuation, only the control and indicating type alarm can be used.

## ALARM PANELS TO AS 5062.

The IFIS alarm panels are designed to Australian Standard AS 5062-2006 for mobile equipment fire suppression. They operate on 12VDC or 24VDC systems.



**Control & Indicating** model with electric manual actuation at the alarm face.

**Indicating** model where pneumatic manual actuation is independant of the alarm.

### COMPLIANCE STATEMENT

The IFES control and indicating alarm panel has been independently assessed for functional compliance to AS 5062-2006 by TUV Rheinland. More information is available on request.



---

## Standard features for both of the IFIS alarms.

Asupervised single Automatic Detection zone fire alarm control.

- **Fire Notification**

There is a supervised input for Fire notification on both panels. The control panel has a second input in case the designer is using a remote electric manual actuator(s). The panel operates using normally open contacts in normal condition bridged by a 47KOhm EOL resistor for supervision. Contacts close to notify the alarm of fire.

- **Cylinder low pressure detector.**

The alarm panel reports cylinder low pressure as a fault and operates using a normally closed contact pressure switch. It is supervised to fault but does not require EOL resistor for supervision.

- **Test and Muting**

In normal condition only, hold the test button for 6 seconds, when 2 beeps are heard, release the button which will put the alarm through a test function. On Control Panels, the actuator circuit will not be activated during this test. This button also functions during an alarm to mute the sound in which case the mute light will illuminate. The alarm sound can be re-activated by pressing the button again, and the mute light will disappear.

- **Isolating and Resetting.**

These alarms can both be isolated and/or reset at any time in any alarm status condition. Resetting/ Isolating is done by a code. Hold the test button down for a period of 6 seconds. When 2 beeps are heard, push the button 3 times. This will place the alarm in "ISOLATED" condition. The alarm will give one short beep every minute to remind the operator that the alarm is still isolated. **WARNING** – The contact outputs will re-set to normal. If either of these are being used for engine shutdown it will be possible to start the machine. If this is done before the fire system is re-instated, there is no fire protection.

Repeat the above process a second time to reset the panel to normal.

- **Engine Shutdown.**

There are two outputs. Normally open and normally closed voltage free contacts with a rated max of 10 amps. These are programmed to operate after a fire alarm at a pre-programmed delay. Six seconds is the default setting. This delay can be re-programmed anywhere between 0 – 24 seconds as determined by risk assessment. After a fire, this will remain latched as required by AS 5062. This can be temporarily overridden without a code while ever the test button is held down. **WARNING** – The contact outputs will re-set to normal. If either of these are being used for engine shutdown it will be possible to start the machine. If this is done before the fire system is re-instated, there is no fire protection. Longer overrides can be achieved by isolating the alarm. This is considered for emergency use only.

Isolating & Resetting (as above) is required to return to normal condition.

- **Event data** is recorded within the alarm memory. This may be viewed and printed to a PDF file is available using the approved alarmware.



## Features for Fire Alarm - Control and Indication Panel only

- **Battery Power Supply**

The POWER supply to the alarm is designed to operate nominally on 12 to 24vDC supply. It also contains internal batteries to allow it to operate for up to 12 -72 hours independantly of the normal power supply. The supply tolerance for operation is 9 to 30VDC. There is internal regulated charging to recharge the internal batteries when power supply is between 12 to 30VDC.

- **Automatic Isolation Option**The control panel is default set such that when power is disconnected, it will revert to battery backup indefinitely. The alarmware can be used to implement a delayed action automatic alarm isolation if required. The delay is programmable to 90 minutes. An example of this feature would be that if the risk assement considered the fire risk only to be present during engine operation, and the customer would prefer the electric fire system functions to be isolated when the engine has been turned off and the engine has cooled down, this feature could be used. If this feature is used, the system automatically resets to normal when power is restored.

- **Actuation relay output**This alarm has an independent power output for electric actuation of the fire system. It is rated at 12VDC at max 1 amp for a timed period of 90 seconds default setting imediately on receipt of fire alarm notification. This period can be re-programmed anywhere between 1 and 90 seconds output.

- **Actuate Switch** To actuate the system, flip open the protective switch cover and push the spring loaded toggle switch.The alarm manual actuatefunction has a protective cover to prevent accidental activation. It also incorporates a secure tie to indicate tampering.

- **Solenoid Valves**Please note that if an IFES solenoid valve is used to release the system, they have a plastic ¼” port plug supplied to protect the exhaust port from foreign materials. When the solenoid releases, this plug is expelled. It is important during installation and maintenance that these are checked and replaced as necessary for commissioning. Earlier installations may have had a sintered filter. This was discontinued in Jan 2016. During maintenance, sintered

filters must be removed and replaced with the plastic ¼” port plug now available.

### Alarm Panel Indicators

- **GreenPower ON** light illuminated – Power supply connected and active.
- **Battery** light **GREEN**-battery fully charged on standby.  
**Battery** light **FlashingGREEN**– system operating on backup Battery.  
**Battery** light **RED** indicates battery is charging.
- **FIRE** Red light – Fire Alarm.
- **Discharge** Light illuminated. System is discharging.
- **Fault** Functions.

The Fire Alarm Panel uses flashing “Fault” LED and sounder beep codes to identify the type of alarm fault. If more than one fault occurs, flashing indication and beeping will occur sequentially.

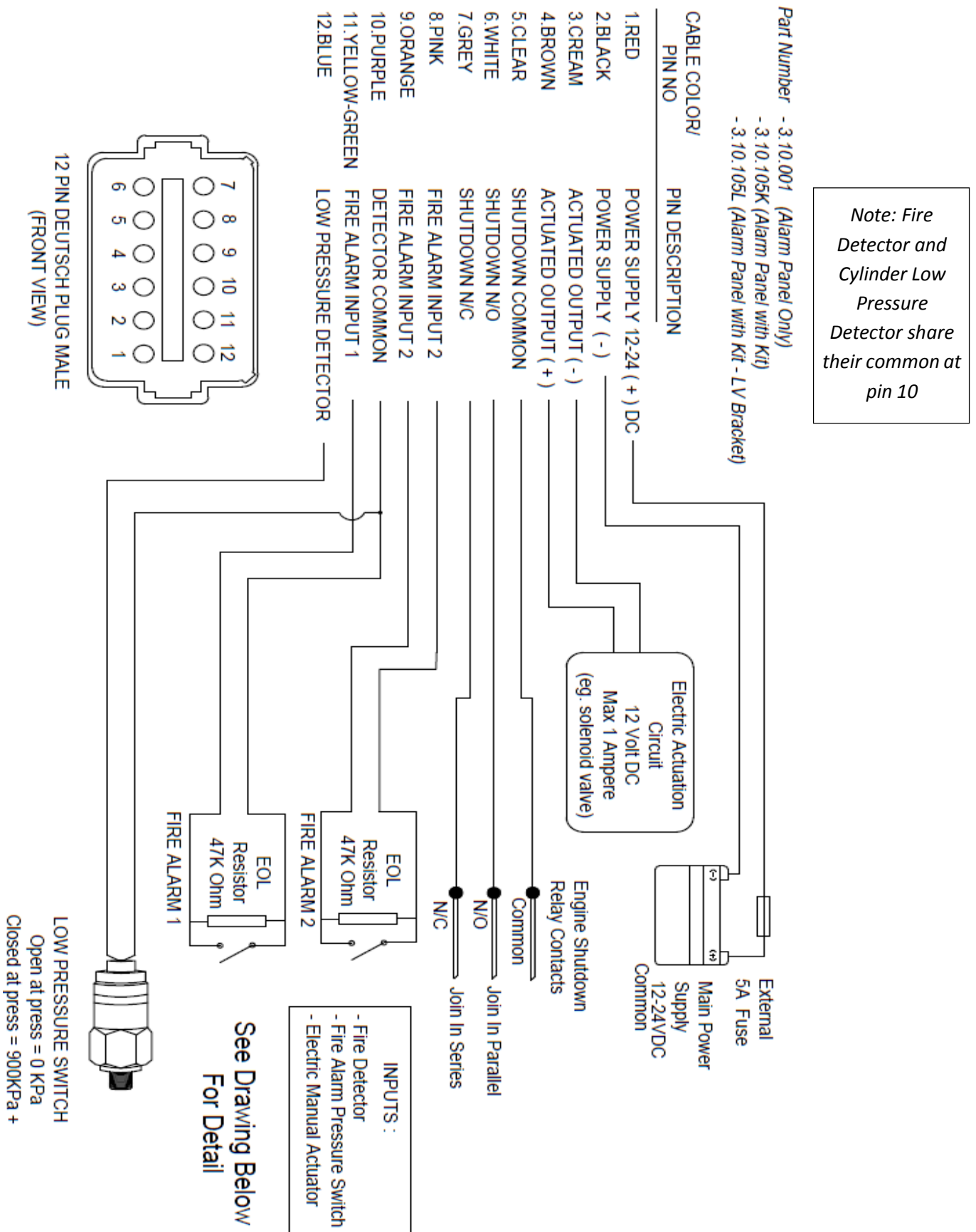
No	Fault Types	Beeps + LED Fault
1	Alarm Input 1	1 Beep + 1 Flash
2	*Alarm Input 2	2 Beeps + 2 Flashes
3	Cylinder Low Pressure	3 Beeps + 3 Flashes
4	*Actuation Circuit	4 Beeps + 4 Flashes
5	*Battery Faulty	5 Beeps + 5 Flashes

*Alarm table fault codes*

*\* Only applies to Control & Indicating panel.*

Fault indications are not latching. This means that the fault indication will disappear when the fault is repaired without resetting the alarm. The fault audible beep sound can be muted by pressing the “Mute” button.

## Fire Alarm Control and Indication Panel Electrical Installation Diagram



## ELECTRIC SOLENOID VALVE



In electric actuated systems a ¼" Ported electric solenoid is included. This Part 3.40.003 and is included in kit Part 4.40.005. When actuated by a 12 VDC current from the Control alarm, it expels the pressure from the LOP Detection and Actuation circuit. This will open the main valve(s) and implement discharge. There are a few important points to note about this critical item.

- 1) It is lubricated when supplied from IFES as of the date of this manual. It must be re-lubricated at least once per year in the annual service. The procedure is on the following page.
- 2) The red push in cap (Part 7.50.208) is pushed into the outlet port 2. Its function is to keep dust out of the valve. When Operated it will be expelled. A spare plug is supplied with every kit and spares should be kept on hand.

## ELECTRIC SOLENOID VALVE – (service procedure)

ELECTRIC CAP



VALVE STEM



SPRING



PLUNGER  
WITH  
SEAL



VALVE BODY



**Strip – Inspect and clean as necessary the solenoid valve assembly. Re-coat plunger and spring with lubricant compound suitable for O ring seals. The IFES listed product is Molykote 111. Re-assemble and test.**

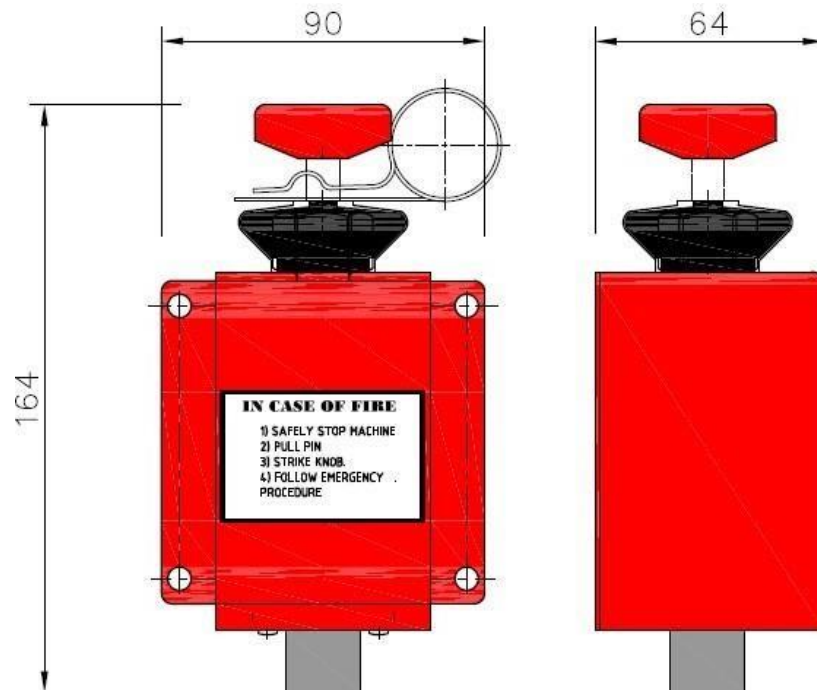




## ELECTRIC REMOTE MANUAL ACTUATORS

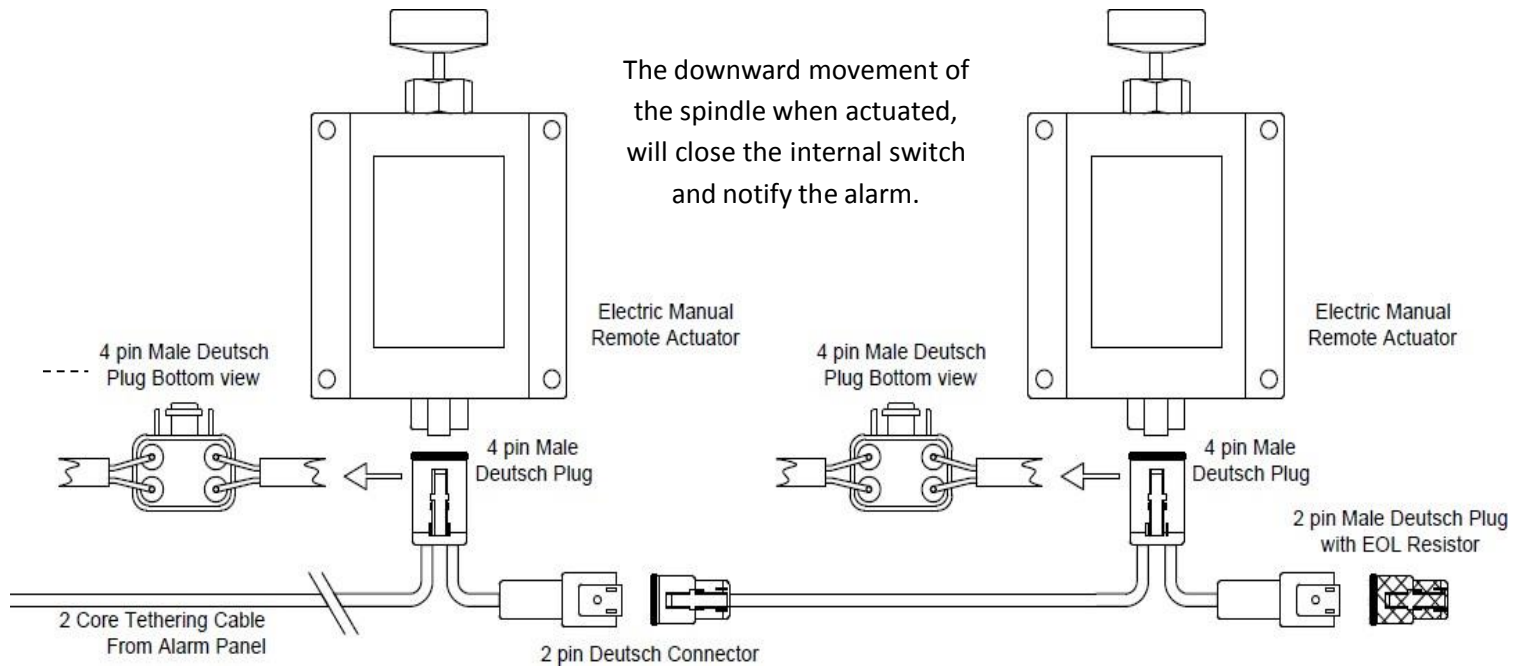


Electric Remote Actuators can only be used with a Control and Indicating alarm that is capable of electrically actuating the system. The housing is made from stainless steel and powder coated and construction is to IP65. A Deutsch 4 pin DT series socket is fitted below and pre wired to the internal normally open contacts. This allows multiple units to be wired in parallel. The end of line unit uses has a 47 K Ohm end of line resistor that ensures the cable and connections are fully supervised. This actuator should be used with the IFES Control and Indicating Panel Part – 3.10.001. This panel already has manual electric remote actuator inputs installed to operate this alarm panel. Pull pin and spindle is stainless steel with a rubber dust boot for added protection.

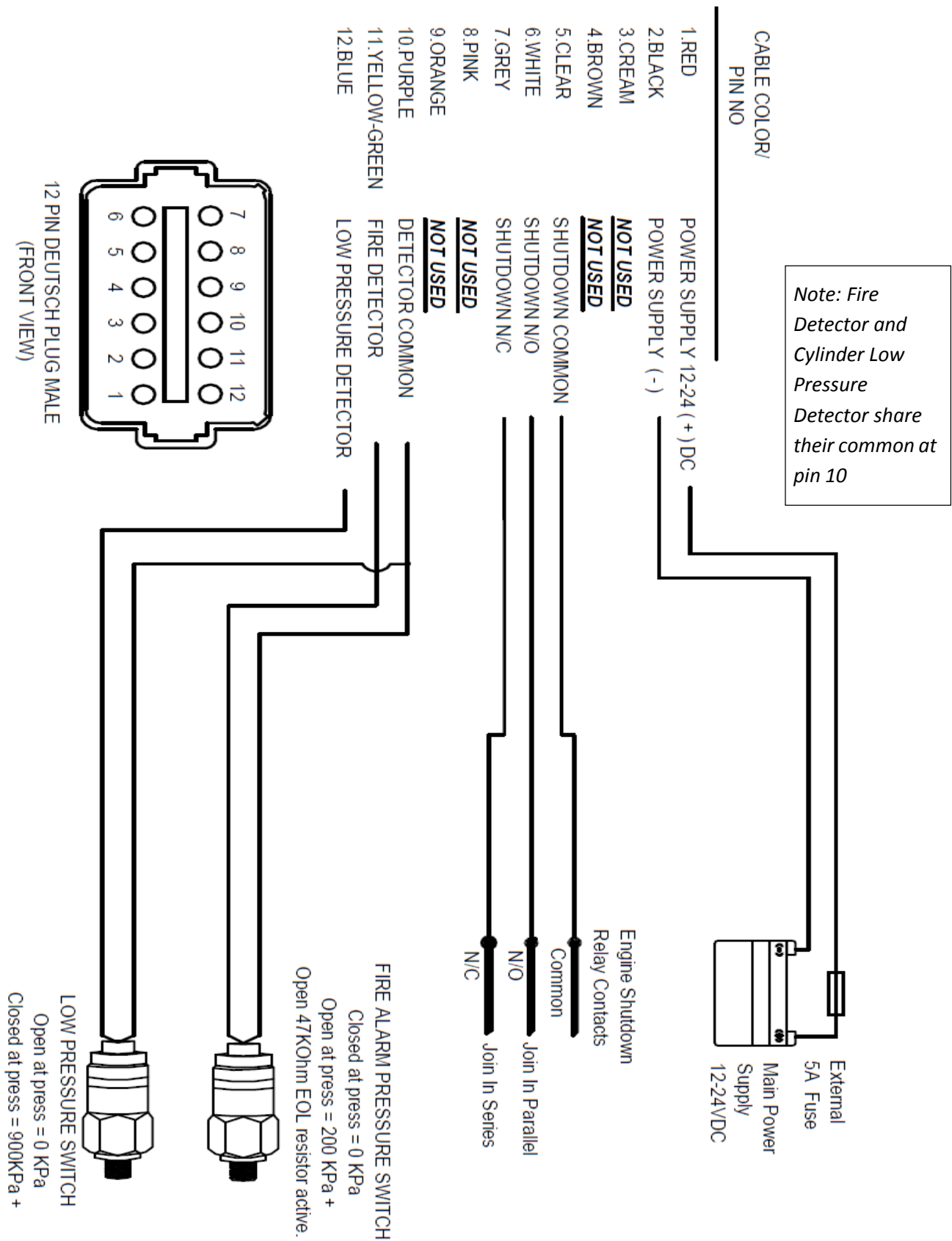


## WIRING REMOTE ELECTRIC ACTUATORS

The downward movement of the spindle when actuated, will close the internal switch and notify the alarm.



## Fire Alarm Indication Panel Electrical Installation Diagram



## Other Specifications

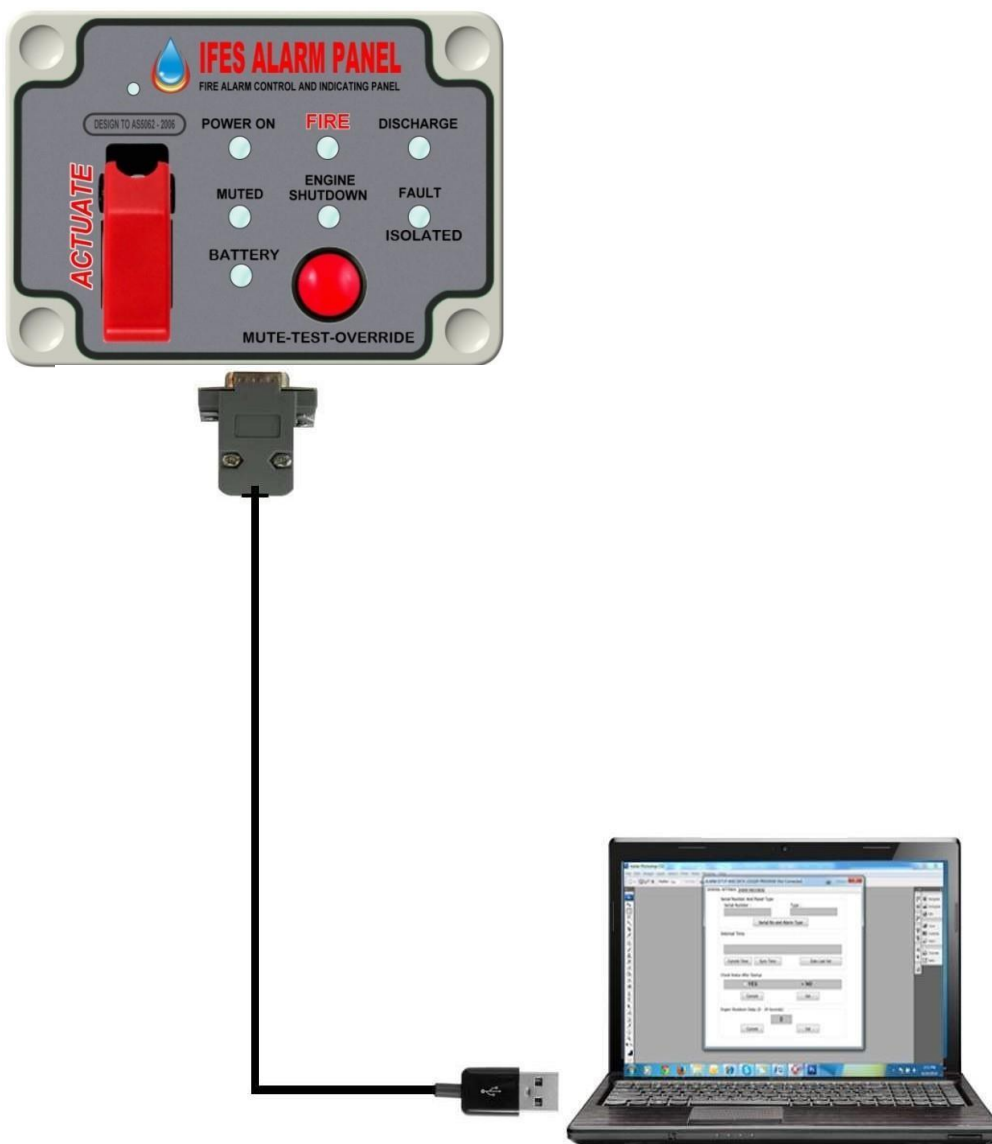
- Power supply 12 -30 Volt DC min 5 amp supply with overload fusing.
- Stand by Current: Max 20mA @24 Volt - 5mA on battery backup. (\*)
- Mechanical Specification  
Dimension            Length: 112mm Width: 80mm        Height: 45mm  
Bracket Dimension:        Length: mm            Width: mm            Height: mm
- Alarm Sounder: 85 dB @ 1Meter.

*(\*) for alarm control and indication only.*

### Optional FIB Firmware Version Notes Type 3.100.003

The IFIS Fire Alarm is manufactured with intelligent software built in. It is factory set with default operating parameters. This feature allows some operating parameters to be changed. It also incorporates an event logger that can be viewed and have data extracted to a PDF format report. Customers or servicing personnel may buy the Firmware kit which includes software and a special USB connection to allow programming on a standard Windows based laptop computers.

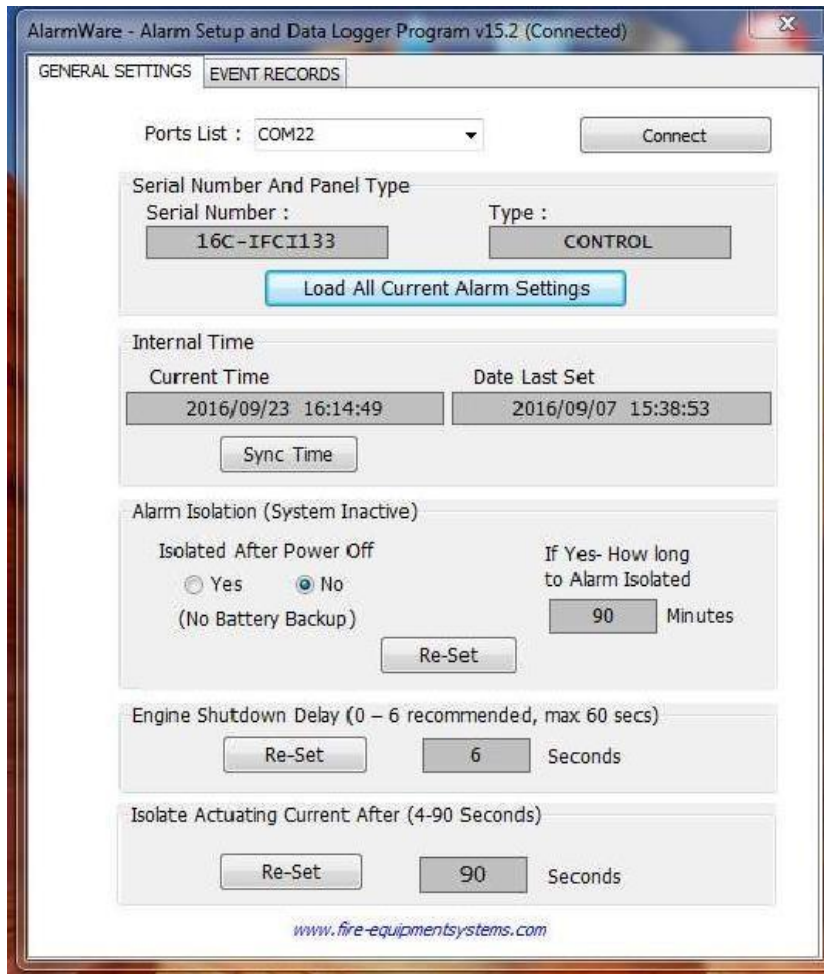
The diagram below shows the simple connection arrangement. The cable to the junction box is temporarily disconnected and the alarm firmware cable shown is used to connect to the alarm panel during reprogramming or viewing and reporting data.





## ALARMWARE - SOFTWARE

The alarm software is used by a trained installation or maintenance technician and has 2 main functions: Firstly to manage the event records of the alarm, and secondly to set time and programmable shutdown delay. The Alarm software works on popular Windows™ environments from XP to version 7. Approximately 20MB of hard drive space is needed.



The features of the AlarmWare are:

- Setting up the alarm panel to record time and date event logging.
- Checking serial number and alarm type.
- Resetting the alarm.
- Checking the event record and printing if required.
- Setting optional start up test function on the alarm.

The alarm settings that may be programmed with AlarmWare are, Engine shutdown delay time, local alarm date and time and automatic self-test setting.

## Installation

1. Run the installation program AW\_Setup.exe.
2. Specify setup destination folder.
3. Wait until setup process is finished. Click “Finish” button to close installation program.
4. Plug the USB cable into a computer, Windows will install driver for USB cable automatically. Allow the installation process to finish.

## Before Programming Process

1. Plug USB cable to computer.
2. Run the AlarmWare program from computer desktop and make sure “Connected” displays at the top of the screen. This indicates that the connecting cable is correctly installed.
3. Plug the USB cable to the alarm.
4. Perform process checks by pressing the “Serial No and alarm type” button. The software will respond by displaying the serial number and alarm type on the screen.

## Button Function – GENERAL SETTINGS (see example above)

1. Serial No and alarm type : To display serial number and type of the Alarm
2. Current Time: To give the alarm the local date and time as it is set from the connected computer.
3. Sync Time: To synchronize alarm local date and time with connected computer.
4. Date Last Set: To display last alarm local date and time sync as per 3. Above. N.B if Sync Time is used, the previous sync details are erased.
5. Current (Check status after start up): Displays current alarm automatic self-test (yes or no).
6. Set (Check status after start up): To re- set alarm automatic self-test (yes or no).
7. Current (Engine Shutdown Delay): Displays current engine shutdown delay time.
8. Set (Engine Shutdown Delay): To re-set engine shutdown delay time (0 to 24 seconds).
9. Read Record.

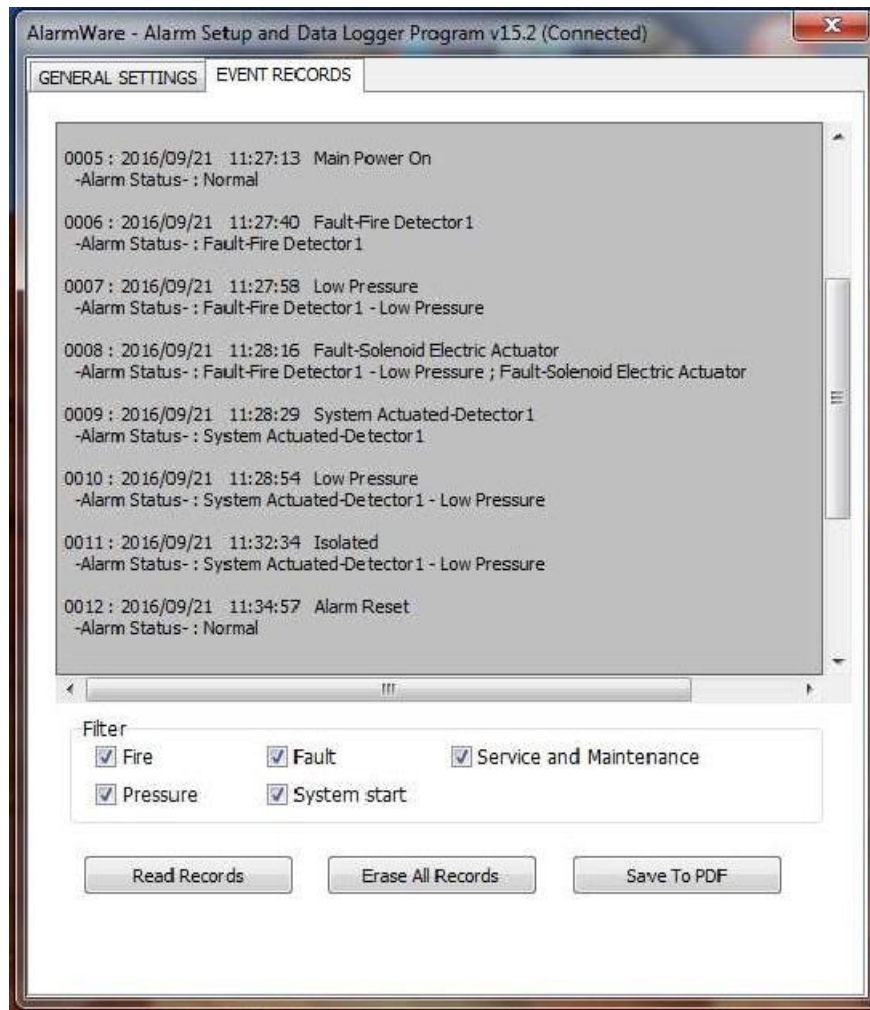
---

## Button Function – EVENT RECORDS (See example below)

1. Click the filter boxes at bottom screen to define data required.  
Default setting- all buttons clicked.
2. Read Records: Will display all events according to the filter options selected
3. Erase all records: Will Erase ALL event records in alarm memory.  
WARNING. These records cannot be recovered. Consider printing current memory to PDF before erasing.
4. Save To PDF: Will create a PDF format file of the events currently on display after filtering.

## EVENT LOGGER

Below is an example of the event logger and the data it can provide. Note “Connected” displays at top screen indicating a successful cable connection installation.



## IFES ALARM PANEL TEST UNIT PART 3.10.080



Picture of test case only. Kit includes extension cable for testing in situ when alarm is installed in a machine.

Also includes a 12 VDC vehicle plug is provided to use the vehicles power.

The IFES alarm panel test unit is a convenient aluminum carry case that allows an IFES Indicating alarm or control and indicating alarm to be fully function tested. The alarm can be connected at the test case or the extension cable can be used to connect in place in the vehicle installation.

### INSTRUCTIONS FOR THIS PANEL







Power is supplied by plugging in any dc power supply of 12 – 19 volts dc with a minimum 2 amp capacity. Many laptop computer power supplies (not included) will suit this. A vehicle plug is provided to plug into the vehicle power supply also. NOTE : It is possible to test a Control and Indicating panel without power connected provided the internal battery is fully charged. However this is not recommended.

**CORRESPONDING CORRECT ALARM INDICATION X MODELS:-  
CONTROL & INDICATING – INDICATING ONLY**



**NORMAL CONDITION WHEN POWER CONNECTED**



**FAULT SIMULATION.** Faults on either of the fire detection circuits or a cylinder low pressure fault may be actuated by toggling the amber button. This will cause the alarm to sound a fault code (as previously described) and the fault lamp will blink the corresponding code.

CORRESPONDING CORRECT ALARM INDICATION X MODELS:-  
CONTROL & INDICATING                      – INDICATING ONLY



FAULT CONDITION - POWER CONNECTED



FIRE ALARM SIMULATION. Fire alarm simulation can be done by pushing either of the silver ACTUATE buttons. This simulates fire detection on either of the two inputs for this function. For Control and Indicating panels, this can also be done on the ACTUATE toggle on the alarm face.

DISCHARGE SIMULATION. When discharge commences, the pressure in the cylinder will reduce and when the 9 bar low pressure level is reached, the low pressure switch will signal the alarm. The alarm interprets this as discharging and indicates accordingly. Simulation is done by pushing the low cylinder pressure fault switch after a fire alarm has been actuated.

CORRESPONDING CORRECT ALARM INDICATION X MODELS:-  
CONTROL & INDICATING                      – INDICATING ONLY



FIRE ALARM CONDITION - POWER CONNECTED  
AFTER SHUTDOWN SEQUENCE AND DISCHARGE SIMULATION

When the alarm is connected and is in normal green light condition, the green light will glow. This indicates that the alarm shutdown function is not operating and the machine is “Green Light” to run.



After a fire alarm is received, the engine shutdown function will operate after the pre-set time delay. The factory pre-set is six (6) seconds but may be programmed anywhere from 0 – 21 seconds. When this operates the green light will extinguish and the red light will illuminate indicating that the engine shutdown function is working.

## IFES ALARM CABLE DIAGNOSTIC PANEL PART 7.100.012



The Alarm diagnostic panel is also a recommended tool for installers of IFES Fire Suppression system. It is used when the wiring to the Power Supply, Low Pressure Switch, The Fire Alarm switch, \* Electric Remote Actuators, \* Fire Detection LHD cable, and the \* Actuation solenoid are wired up to the serial plug cable that connects to the alarm. Before connecting it to the alarm, connect it to the Cable Test unit. This provides an easy and quick check of the cable connections before connecting the alarm panel.

- 1) POWER SUPPLY - If power is connected correctly, the lamp will illuminate.



There are four pairs of stainless steel terminals. A multi meter can be quickly connected to these pairs to verify correct reading. A good procedure here, is to use your Nitrogen regulator to pre-pressure the LOP detection and actuation system to normal 13.7 Bar pressure. This way we can test the electrical functions in normal condition. However the correct indications are printed on the panel if it is in unpressurised condition.

- 2) **LOW PRESSURE SWITCH** – Set the multimeter to continuity test. Most multimeters give a beep sound when there is continuity and no sound when there is not. If the circuit is pressurised, there should be continuity and if unpressurised there should not be continuity.
- 3) **ALARM PRESSURE SWITCH** – In pressurised condition, set the multimeter to read resistance in K Ohms. The reading should be 47 K Ohms + or – 5 K Ohms. In unpressurised condition, set the multimeter to continuity test. There should be continuity.
- 4) **ACTUATION SOLENOID**. \* Note: This must only be connected to a Control & Indicating panel. Set the multimeter to Resistance in Ohms. The result should be 12 – 14 Ohms, regardless if the system is pressurised.
- 5) **ELECTRIC MANUAL ACTUATOR**. \* Note 1: This must only be connected to a Control & Indicating panel. Note 2: Depending on the design, this may also be used to for LHD fire detection.

Set the multimeter to read resistance in K Ohms. The reading should be 47 K Ohms + or – 5 K Ohms. In activated condition set the multimeter to continuity test. There should be continuity.

#### TIPS

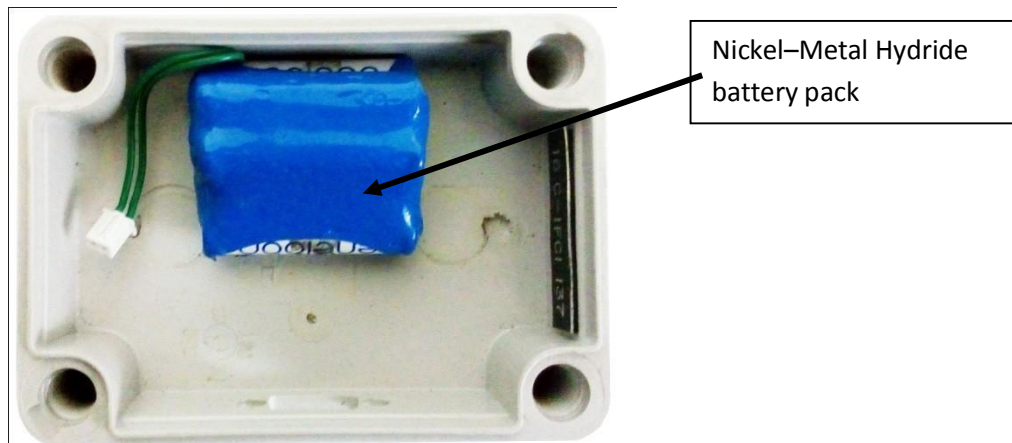
- A) The 47 K Ohm indication is checking the end of line resistor. This is used in the Alarm Pressure switch, LHD cable detection and remote electric manual actuators.
- B) On the solenoid, the 12 – 14 Ohm resistance is reading the actuation coil. If it is absent, the coil may be disconnected or faulty.



## BATTERY MAINTENANCE FOR CONTROL PANEL

### INTERNAL BATTERY BACKUP PACK

The Nickel–metal hydride battery pack shall be replaced annually during the annual periodic test and inspection or earlier if a battery failure occurs. Simply unplug the old unit and replace and plug in the new unit. Dates of replacement must be recorded in service records. See diagram below. Batteries are not warranted by IFES.



### BATTERY FOR CIRCUIT BOARD EVENT LOGGER MEMORY

The upper circuit board event logger memory battery shall be replaced annually during the annual periodic test and inspection. Simply unclip the old unit and replace with the new unit. Dates of replacement must be recorded in service records. See diagram below. **WARNING** Battery replacement will cause all current memory to be lost, and date and time functions will need to be reset using the AlarmWare. It is recommended that existing data be saved to a PDF file before changing this battery.

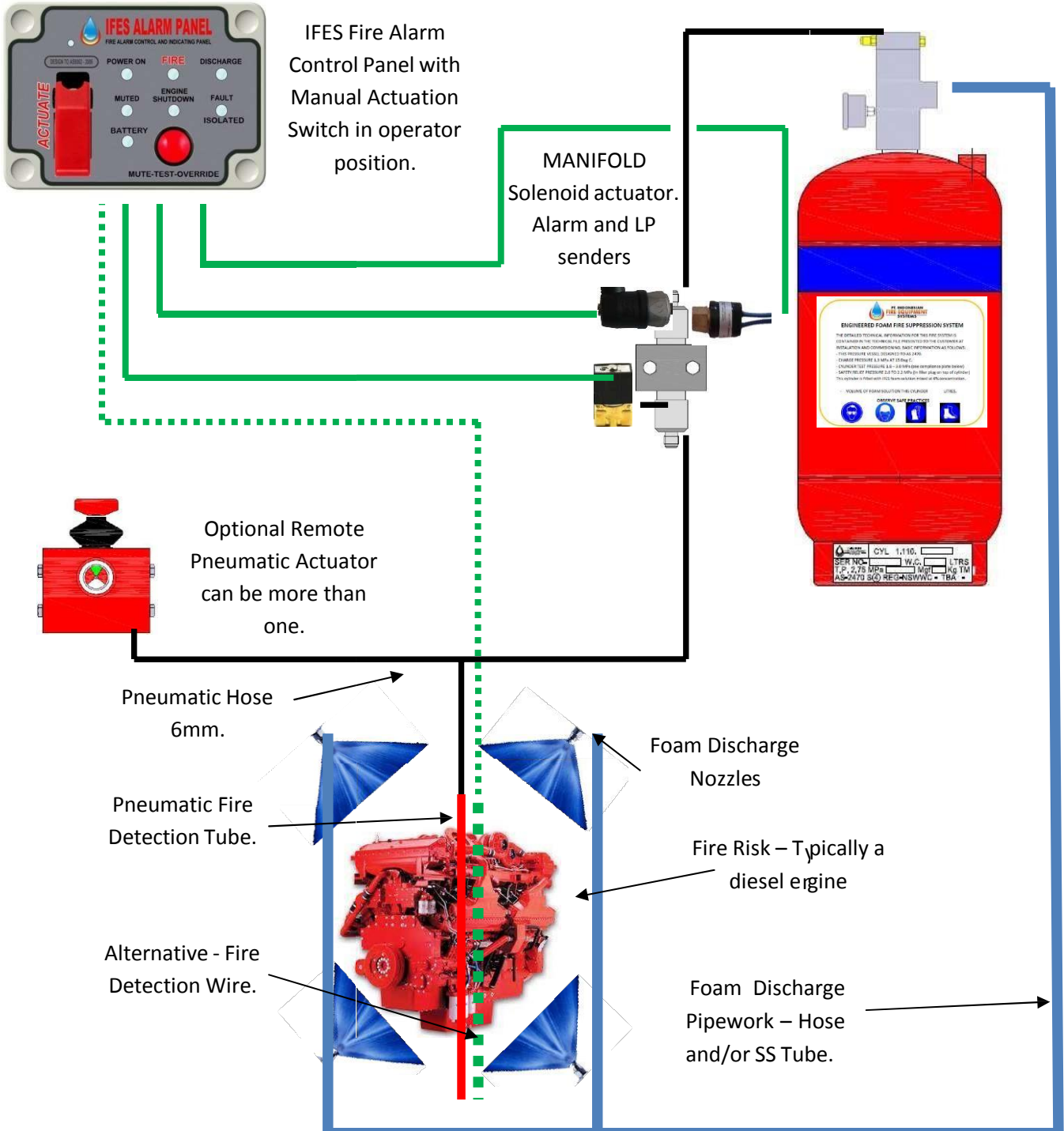




A stainless steel swivel mount bracket is available to provide adjustable angle mounting on flat surfaces.

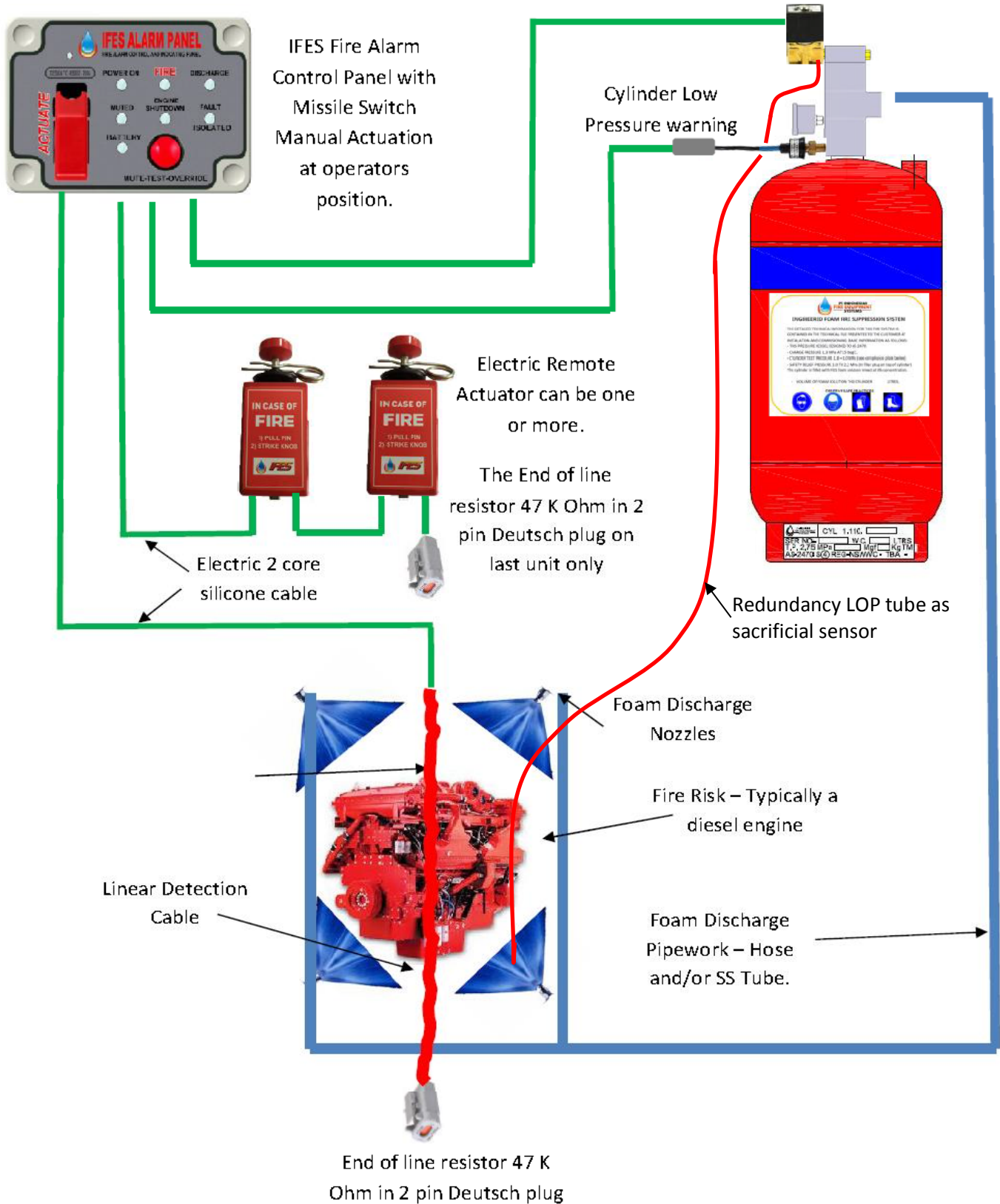
## 5 COMMISSIONING AND MAINTENANCE

### APPENDIX A – BASIC SCHEMATIC CONCEPT – CONTROL PANEL TYPE ALARM WITH LOP MANUAL ACTUATOR AND CHOICE OF LOP DETECTION TUBE OR LINEAR DETECTION CABLE ACTUATION.

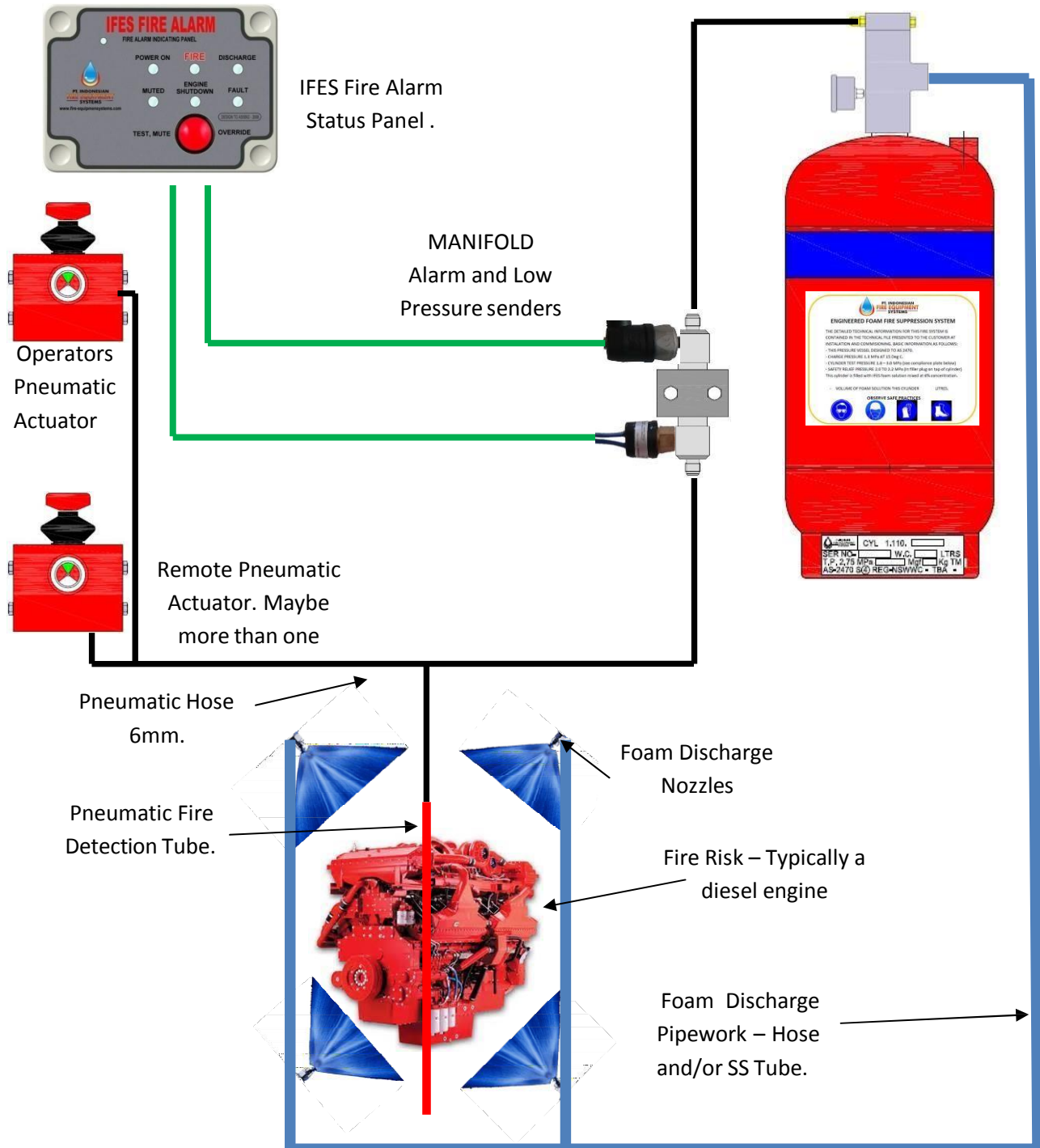


**APPENDIX B – BASIC SCHEMATIC CONCEPT – CONTROL PANEL TYPE ALARM WITH ELECTRIC MANUAL ACTUATORS AND LINEAR DETECTION CABLE ACTUATION. THE LOP REDUNDANCY SENSOR IS MANDATORY.**

Solenoid actuator.



**APPENDIX C – BASIC SCHEMATIC CONCEPT – INDICATING PANEL TYPE ALARM WITH TWO LOP  
MANUAL ACTUATORS AND LOP DETECTION TUBE.**





---

**APPENDIX D P 1 of 3**– SAMPLE OF COMMISSIONING REPORT PRODUCED IN THE DESIGN SOFTWARE.

---

## COMMISSIONING REPORT

Name and installer \_\_\_\_\_

Address \_\_\_\_\_

Commissioning date \_\_\_\_\_

Type of fire protection system \_\_\_\_\_

This system has been installed in accordance with manufacturer's design documentation and AS 5062—2006.

Name of client \_\_\_\_\_

Equipment being protected (make/model) \_\_\_\_\_

Equipment identification/serial number \_\_\_\_\_

Fire hazard locations being protected \_\_\_\_\_

Extinguishing agent container serial number \_\_\_\_\_

Discharge completed Y/N (circle) \_\_\_\_\_ Nozzle coverage acceptable Y/N (circle)

Design discharge time \_\_\_\_\_

Actual discharge time \_\_\_\_\_

Equipment shutdown delay period \_\_\_\_\_



**APPENDIX D P 2 of 3** – SAMPLE OF COMMISSIONING REPORT PRODUCED IN THE DESIGN SOFTWARE.

Item	Task	Reference from listed manual or Clause number from AS 5062	Compliance (Mark: Yes, No, or Not applicable)
1.	System configuration		
2.	Signs and warning labels		
3.	Containers:		
	(a) Location		
	(b) Number		
	(c) Size		
	(d) Marking		
	(e) Charge quantity		
	(f) Fill weight		
	(g) Orientation		
4.	Release mechanisms:		
	(a) Location		
	(b) Connections		
	(c) Pneumatic leak test of actuation pressure lines (where fitted)		
	(d) Mechanical release		
5.	Manifolds and valves – Location and number:		
	(a) Joints and fastenings		
	(b) Flexible connections		
	(c) Discharge indicators		
	(d) Pressure switches		
	(e) Check valves		
	(f) Pressure relief devices		
	(g) Vent valves		
6.	Distribution systems		
	(a) (i) Layout		
	(ii) Size and fitting orientation		
	(iii) Joints, nozzles and supports		
	(b) Leak test		
7.	Nozzles		
	(a) Identification		
	(b) Orientation		
8.	Electrical system		

**APPENDIX D P 3 of 3 – SAMPLE OF COMMISSIONING REPORT PRODUCED IN THE DESIGN SOFTWARE.**

Item	Task	Reference from listed manual or Clause number from AS 5062	Compliance (Mark: Yes, No, or Not applicable)
9.	Function tests		
	(a) Local alarm		
	(b) Equipment shutdown		
10.	Actuation system test		
	(a) Audible alarms		
	(b) Audible and visual alarms time delay		
	(c) Shutdown override		
	(d) Discharge time delay		

Additional Remarks : \_\_\_\_\_  
 \_\_\_\_\_  
 \_\_\_\_\_  
 \_\_\_\_\_

Signature of installer \_\_\_\_\_

Position \_\_\_\_\_

Date \_\_\_\_\_

Accreditation No \_\_\_\_\_

**APPENDIX E P 1 of 3 – SAMPLE OF CERTIFICATE OF COMPLETION PRODUCED IN THE DESIGN SOFTWARE.**

## CERTIFICATE OF COMPLETION

### PART 1: TO BE COMPLETED BEFORE TESTING

We {name of installer} \_\_\_\_\_  
of {address} \_\_\_\_\_  
hereby certify that we have completed on {date} \_\_\_\_\_  
a {name of system} \_\_\_\_\_ fire extinguishing installation/  
extension(s) designed by \_\_\_\_\_  
in accordance with design documentation \_\_\_\_\_  
and installed in accordance with AS 5062—2006.

Name of client \_\_\_\_\_

Equipment being protected {make/model} \_\_\_\_\_

Identification number \_\_\_\_\_

Fire hazard locations being protected \_\_\_\_\_

Type of system \_\_\_\_\_

Storage arrangement \_\_\_\_\_

Hazard location	Actuation method (automatic/manual)	Agent quantity	No. of containers	No. of nozzles	Applicable drawing(s)

**APPENDIX E P 2 of 3 – SAMPLE OF CERTIFICATE OF COMPLETION PRODUCED IN THE DESIGN SOFTWARE**

**Functional parameters (tick)**

Functional interfaces with equipment system	<input type="checkbox"/>	Engine shutdown	<input type="checkbox"/>
Air handling shutdown	<input type="checkbox"/>	Fuel shut-off	<input type="checkbox"/>
_____	<input type="checkbox"/>	_____	<input type="checkbox"/>
_____	<input type="checkbox"/>	_____	<input type="checkbox"/>

Variations from this Standard previously agreed to by the authority having jurisdiction are attached (Clause references and related variations should be listed).

**Detection system details:**

Detection Area	Detection Type	No. of Points	Circuit Material

**Actuation system details:**

Actuator Area	Actuator Type	Manual / Auto	Circuit Material

**Suppression system details:**

Protected Area	Suppression Type	No. of Nozzles	Delivery Material

**APPENDIX E P 3 of 3 – SAMPLE OF CERTIFICATE OF COMPLETION PRODUCED IN THE DESIGN SOFTWARE**

**PART 2: TO BE COMPLETED AFTER TESTING**

Commissioning test(s) conducted by .....

..... Date .....

Commissioning test(s) witnessed by .....

..... Date .....

Discharge test conducted by .....

..... Date .....

Discharge test witnessed by .....

..... Date .....

Remarks .....

.....

.....

.....

**APPENDIX F INSPECTION SCHEDULES PER AS 5062-2006 TABLE 11.1**

Item No.	Item	Action required and pass/fail requirement	Frequency			Result	Pass/fail	Comments
			Daily *	Six-monthly	Yearly			
1.1	Storage container pressure	<b>Check</b> valve and remote actuator pressure indicators are visible and read within normal range.	√	√	√			
1.2	Manual actuators	(a) <b>Check</b> that all release anti-tamper seals/pull pins are in place and secure.	√	√	√			
		(b) <b>Check</b> that all actuators are secure, clean, undamaged and accessible.	√	√	√			
1.3	System control and indicating equipment where fitted (See Clause 9.6)	(a) <b>Check</b> that all indicators show normal condition.	√	√	√			
		(b) <b>Check</b> that all panels are secure, clean, undamaged and accessible.	√	√	√			
1.4	Distribution system	(a) <b>Check</b> nozzle caps are in place, if not, clean nozzle and replace caps.		√	√			
		(b) <b>Check</b> nozzle are pointing at pre-determined aiming points.		√	√			
		(c) <b>Check</b> distribution system, (hoses, tube, fittings, and supports) are intact and not damaged.		√	√			
1.5	Actuation system	(a) Pneumatic actuation system (if fitted) – <b>Check</b> hoses, tube, fitting and supports are intact and not damaged.		√	√			
		(b) Electric actuation systems (if fitted) – <b>Check</b> wiring, connections supports are intact and not damaged.		√	√			



APPENDIX F ( Continued )

Item No	Item	Action required and pass/fail requirement	Frequency			Result	Pass /fail	Comments
			Daily *	Six-monthly	Yearly			
1.6	Detection system	(a) Pneumatic detection system (if fitted) – <b>Check</b> detection hoses, tube, fittings and supports are intact and not damaged and are in position. (b) Electric detection system (if fitted) – <b>Check</b> linear cable, wiring, connection and supports are in intact, not damaged and detectors are in position.		√	√			
1.7	Labels	<b>Check</b> manual release, system warning and instruction labels are securely in place, visible and legible.		√	√			
1.8	Storage containers	(a) <b>Check</b> storage containers and valve are not damaged.  (b) <b>Check</b> storage container and mounting bracket are secure. (c) <b>Remove</b> container and inspect mounting bracket and container for damaged and condition. Inspect cylinder internally and externally as per AS2030.1  (d) <b>Check</b> storage container label is securely in place, visible and legible. (e) <b>Check</b> date of test or manufacture on storage container. Re-test or replace After 5 years in service.		√	√			
						..... date		

**APPENDIX G TESTING SCHEDULES PER AS 5062-2006 TABLE 11.2**

Item No.	Item	Action required and pass/fail requirement	Frequency		Result	Pass / fail	Comments
			Six-monthly	Yearly			
2.1	Manual actuators	(a) <b>Physically check</b> that all actuators are secure, clean, undamaged and accessible. (b) <b>Test operation.</b>	√ √	√ √			
2.2	Systems control and indicating equipment where fitted	(a) <b>Test</b> all indicators and audible alarms. (b) <b>Physically check</b> that all panels are secure. (c) <b>Replace</b> batteries.	√ √	√ √			
2.4	Distribution system	<b>Conduct clear-passage test</b> Physically check distribution system, (i.e. that hoses, tube, fittings and supports are secure).		√			
2.5	Actuation system	(a) Pneumatic actuation system (if fitted)– (i) <b>Test</b> pneumatic circuits for leaks. (ii) <b>Physically check</b> hoses, tube, fittings and supports are secure (b) Electric Actuation system (if fitted)– (i) <b>Function test</b> all actuation circuits (ii) <b>Check</b> all wiring for earths. (iii) <b>Physically check</b> wiring, connections and supports are secure.		√ √ √ √ √			<p><b>SERVICE ELECTRIC SELENOID VALVE ON ANNUAL TEST</b></p> <p><b>-SEE PAGE 34.</b></p>
2.6	Detection system	(a) Pneumatic detection system (if fitted)– (i) <b>Test</b> pneumatic circuits for leaks. (ii) <b>Check</b> hoses, tube, fittings and support are secure.		√ √			

**APPENDIX G** (continued)

Item No.	Item	Action required and pass/fail requirement	Frequency		Result	Pass / fail	Comments
			Six-monthly	Yearly			
		(b) Electric detection system (if fitted)– (i) <b>Function test</b> all detectors. (ii) <b>Check</b> all wiring for earths. (iii) <b>Check</b> wiring, connections and supports are secure.		√ √ √			
2.7	Discharge test	(a) <b>Conduct discharge test</b> and record result  (b) <b>Check</b> fire suppression system nozzle area coverage.		√ √	.....sec		
2.8	System interface and shutdown	Test all fire suppression system activated equipment shutdowns and record delay time.		√	.....sec		

**APPENDIX H PREVENTIVE MAINTENANCE SCHEDULE AS PER AS 5062-2006 TABLE 11.3**

Item No.	Item	Action required & pass/fail requirement	Frequency			Result	Pass/fail	Comments
			Six-monthly	Yearly	Five-yearly			
3.4	Nozzles	<b>Remove</b> all nozzle caps, <b>clean</b> nozzles, relube, and refit caps.	√	√	√			
3.1	Detector sensing element with a listed lifetime	<b>Replace</b> any detector sensing element that will exceed its listed lifetime prior to the next scheduled maintenance. LOP Tube 3 years Linear detection Cable 3 years		√	√			
3.2	Pyrotechnic actuators	<b>Not Applicable this system</b>						
3.3	Mechanical actuator	<b>Service and lubricate</b> all mechanical actuators in accordance with the manufacturer's recommendations.		√	√			
3.5	Strainers, filters and check valves (where fitted)	Clean or replace sintered filters.	√	√	√			
3.6	Container	(a) <b>Subject the container to a hydrostatic pressure test</b> in accordance with AS 2030.1. or replace. (b) <b>Replace</b> container valve seats and seals at this time. (c) <b>Replace</b> filler plug relief when 3 years in service.			√			
3.7	Container valves	<b>Service and lubricate</b> during annual test.		√	√			
3.8	Extinguishing agent	(a) Foam Pre-mix solution – replace		√	√			

**APPENDIX I SURVEY SCHEDULES PER AS 5062-2006 TABLE 11.4**

Item No.	Item	Action required & pass/fail requirement	Frequency		Result	Pass/fail	Comments
			Yearly	Five-yearly			
4.1	Nozzle obstructions	<b>Check</b> for adequate clear space at nozzles and for obstructions likely to impede discharge.	√	√			
4.2	Nozzle orientation	<b>Check</b> nozzles are pointing at the pre-determined aiming points.	√	√			
4.3	Nozzle location and coverage	<b>Check</b> for the introduction of fixtures and bulkheads shielding nozzle discharge and the presence of unprotected hazard areas, particularly where a source of fuel and heat exists.	√	√			
4.4	Detector coverage	<b>Check</b> for the presence of unprotected hazard areas, particularly where a source of fuel and heat exists.	√	√			
4.5	Operational conditions	<b>Check</b> that the detector response and extinguishing agent discharge or retention will not be adversely affected by such things as enclosure openings, ventilation airflows or high temperature protected areas.	√	√			
4.6	Environmental conditions	<b>Check</b> that the fire system and its components are suitable for the environmental conditions in which the machine is operating, for example that components are suitable for underground mining, and road gradient and slopes are within cylinder orientation limits.	√	√			

## SECTION 6 COMPONENT COMPLIANCE

For compliance to AS 5062 and IFES Listing, all components supplied shall comply to one of the following classifications:

6.1 PARTS SUPPLIED BY IFES. Parts supplied by IFES in compliance to their certification and listing.

6.2 PARTS SUPPLIED BY AN AUTHORISED DEALER OF IFES. In some cases, IFES will authorise dealers to independently source some components. For this to be authorised, it must be in writing from IFES and clearly state the limitation of what parts authorised dealer may source. These must comply to the below points.

### ACCEPTABLE STANDARDS FOR SOURCING COMPONENTS IN AGREEMENT WITH IFES.

6.2.1 GENERAL – All component shall be specified by IFES and also meet any requirements of as 5062-2016.

6.2.2 HOSES. Hoses shall be compliant to the American Society of Automotive Engineers (SAE) to SAE 100R1 or SAE 100R2. These hoses must also comply to the United States Department of Labour, Mine Safety and Health Administration (MSHA) to Schedule 2G Flame Resistance requirements.

6.2.3 CONNECTING HYDRAULIC FITTINGS, FLARED TYPE – Fittings that seal on mating tapered seats shall be (Joint Industry Council) type fittings JIC fittings and comply to SAE J514. These use a flared seat machined with a 37-degree angle.

6.2.4 THREADED HYDRAULIC CONNECTIONS – Fittings that use pipe standard threaded connections shall be British Standard Pipe (BSP) and shall comply to BS EN ISO 228.

SEALING THREADED CONNECTIONS THAT RELY ON SEALANT BETWEEN THE THREAD FORMS. The approved and recommended sealant during building systems is HENKEL LOCTITE 569. Refer To manufacturer's instructions. Ideal cure time is 24 hours before applying pressure HENKEL LOCTITE 567 is recommended for repair work where there is not sufficient time to wait 24 hours. Used alone, the recommended cure time before pressurising is 3 hours. If a faster result is needed, use a HENKEL ACTIVATOR such as SF 7471.



WARNING – Incorrectly sealed joints in the LOP system can be a major cause of system leaks. Avoid using low grade or non-genuine products.

6.2.5 HYDRAULIC TUBE. Shall be stainless steel, fully annealed (Type 304, 304/304L, 316, 316/316L, 317, 317/317L, 321, 347) (seamless or welded and drawn) stainless steel hydraulic tubing, ASTM A269 and A213, or equivalent. Hardness not to exceed 90 HRB or 200 HV. Tubing to be free of scratches, suitable for bending and flaring.

---

## SECTION 7 ADDENDUM – ISSUE RECORDS & AMENDMENTS

### ISSUE 18-1 APRIL 2018

This added the details and instructions for the alarm test kit and the cable diagnostic panel

### ISSUE 18-2MAY 2018

Technical details added for electric remote actuators and fire wire.

### ISSUE 18-3 APRIL 2018

Alarm panel wiring diagrams upgraded to include new colour coded wiring plan.

### ISSUE 19-1 JANUARY 2019

- Section 6 Added regarding component compliance.
- Nozzle range clarified P-21.

### ISSUE 20 – 1 FEBRUARY 2020

- Pages 33 and 34 added to give important servicing information regarding solenoid release valves on electric systems.

### ISSUE 22 – 10 OCTOBER 2022

- Page 32 Change improved version of the wiring diagram for Control Indicating panels.
- Page 36 Change latest version of the double electric manual actuator wiring diagram.
- Page 37 Change improved version of the wiring diagram for Indicating panels.
- Appendix hierarchy changed – add new concept schematic for full electric system at Appendix B
- Revise Index Page to follow additional Appendix insert.