



WEB-ENABLED 2-WAY AUDIO/VIDEO ENTRY SYSTEM

Our Vandal-Resistant Design keeps your building SAFE.

VISION-1200

12" Touchscreen Entry System

Webb Electronics has pioneered a new entry system that will transform the access-system industry. The Webb Vision-1200 is a web-enabled entry access system specifically design for multi-residential buildings and office towers. Compact and modern, the Vision-1200 truly brings together form and function with a gesture-controlled touch screen, multi-lingual voice prompts and complete integration into the Webb Vision product line.

The Webb Vision-1200 features a NEMA 4 and IP66 rated stainless steel body equipped with 12" vandal resistant touchscreen display. Its seamless integration with the Webb Vision ecosystem establishes this model as the perfect choice for both outdoors and indoors applications.

The Vision-1200 has all the key security requirements you would expect from a state-of-the-art system including lobby door and/or elevator floor restrictions and scalability to incorporate future reader technologies. Optional features include mobile phone app integration for two-way video calling, parcel delivery and amenity booking and QR code temporary access for visitors.



Product Highlights

- Linux O/S Web based architecture
- Standalone or networked
- Touch Screen Interface
- External Low Voltage Supply for Retrofits
- VOIP / Digital Dialing Messaging Services
- Site Specific Web Services and Hot Buttons
- Remote Security and Advanced A/V Features
- Multi-Lingual Voice Prompts
- AODA and ADA compliant solution
- Internet/Intranet/PSTN/Cellular Accessible
- Access/Elevator Control
- Free Remote Updates and Patches as required with an active Webb Vision Phone service plan
- Future-proofed via modular expansion design
- Connects to WEBB VISION companion APP





VISION-1200

Vision-1200 Entry System

All events are logged with optional motion video and audio capture for every visitor. Accessing the Entry Phone. The Resident may: Allow Lobby and/or Elevator Access or Reject the Caller via the App or a by pressing 6 or 9 for a conventional audio only call.

Communications

The Entry Phone provides three modes of communication, PSTN, VOIP and Cellular Services, thus permitting the lowest cost installation and highest possible features for any client. VOIP Permit unlimited simultaneous Voice and Video channels via the Webb Vision App.

Software

Browser based software ensures this product does not require any client software to be installed on a PC and can be programmed by any PC, tablet, or phone Android or iOS. Changes to the directory maybe made on-site over a LAN or remote from the Internet. SaaS Cloud services are available to provide automated back-up and monitor the health of your Vision-1200. The issuance of QR codes to allow visitors and contractors temporary access is also seamlessly managed through the software.

Features

Vandal Proof Housing
Wall and flush Mount for vestibules or lobbies
Indoor Housing
Browser based programming
Environmental Control
Auto Check™ - Remote Health Monitoring*
12" Touchscreen Display for Superior Graphics
Screen Saver
Two Way Audio and Video and Texting Capable with Webb Vision App*
Send/Receive Calls from Guard's Station
Remote Software Upgrades via Internet
On-site Concierge Software
Interfaces with Webb Electronics WEX-305 Servers

Optional

Internal Card Reader(s) For Resident Access
Internal Camera for Video Capture and
Access Postal Keylock for Mail Delivery
Indoor/Outdoor Wheelchair Paddle

Specifications

Dimensions	13.8"(W) x 15.3" (H) x 3.9" (D) 35 cm (W) x 38.8cm (H) x 10cm (D)
Shipping Dimensions	15"(W) x 17" (H) x 6" (D) 38cm (W) x 43cm (H) x 15cm (D)
Shipping weight	13 lbs (6kg)
Input Voltage	120VAC @ 3A / 48 VDC / PoE
Mounting	Flat Surface
Material Finish	High Grade 12-gauge Steel // Vandal Proof Housing
Protocol	1 Gb Ethernet with internet access.
Relay Output	1 x 3A for Maglocks and Door Strikes
Display	12" Color Touch Screen
Touch Screen	Resistive // Weatherproof
User Operation	Gesture based Touch Screen
Audio Output	Adjustable – 5.0 watts
Voice Communication	Hands-free Mode to Suite Panel; Telephone System.
Optional Guard Phone	WDP-304
Directory Listings	Unlimited
Ordering Info	Webb Vision 1200
Options	Webb Vision 1200 Flush Mount (w/ trim ring)

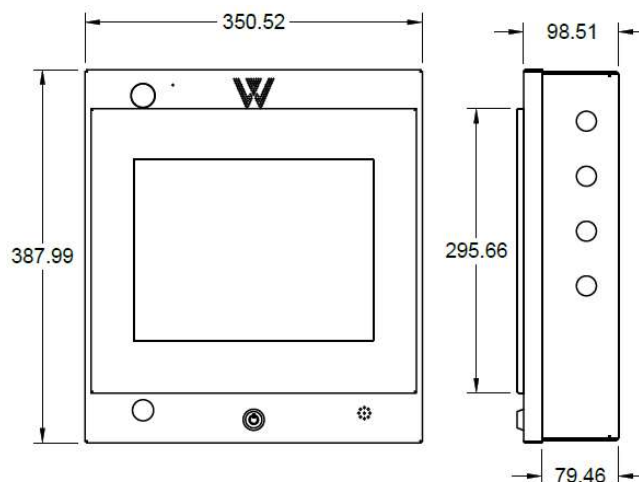

Features and Specifications subject to change without notice. Contact your Webb Vision dealer to select features best suited for your facility and budgetary needs.



1-877-731-1010 · sales@webbvision.com · www.webbvision.com
 Webb Vision™ products are distributed by Webb Electronics Ltd.
 Vancouver · Toronto · Montreal · New York