

PRECISION  
SCREW  
TIGHTENING

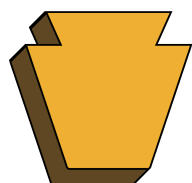

# ELECTRIC SCREWDRIVERS Catalog



**KEYSTONE**  
ASSEMBLY SOLUTIONS, LLC

**KOLVER®**

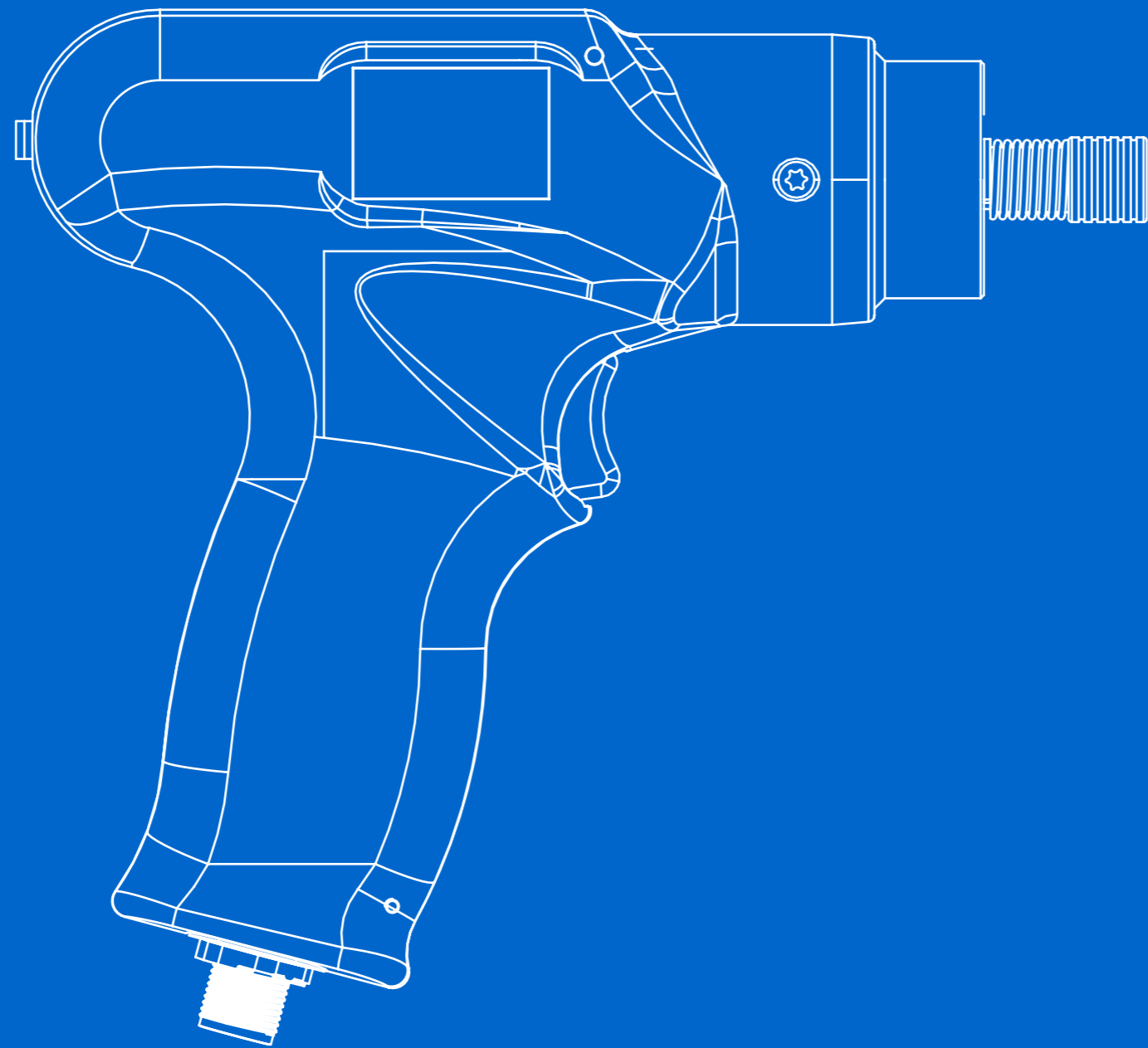
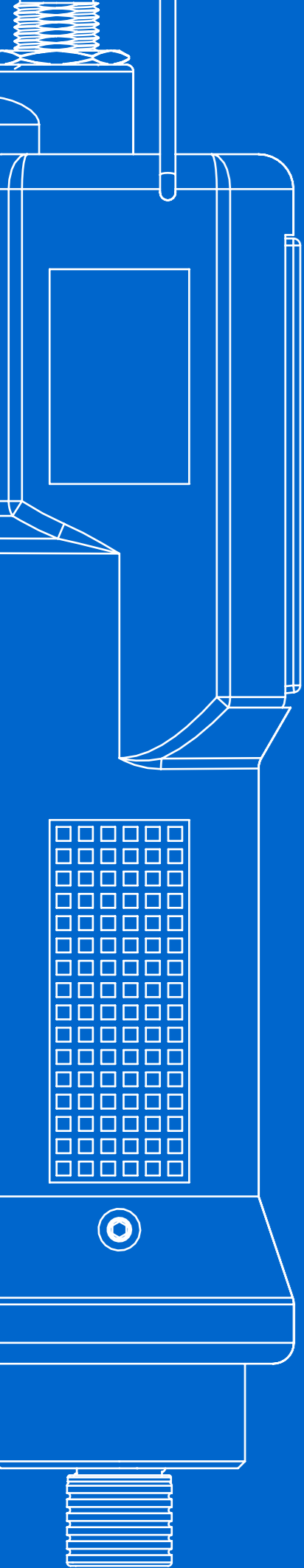

**KOLVER<sup>®</sup>**

## CONTENTS

### **K-DUCER TRANSDUCERIZED SCREWDRIVERS**

KDS Hand-held Screwdrivers	8
KDS Screwdrivers for Automation	10
KDU Controllers	12
Cables	14

### **CURRENT-CONTROLLED SCREWDRIVERS**

PLUTO, MITO and NATO Screwdrivers	17
EDU2AE Control Units	20
PLUTO, MITO and NATO Screwdrivers for Automation	22

### **CLUTCH SCREWDRIVERS**

FAB & RAF Screwdrivers	24
KBL Brushless Screwdrivers	26
KBL Screwdrivers for Automation	28
ACC Screwdrivers	30

### **TORQUE TESTERS**

K-TESTER Series	32
Mini K/S Series	32

### **REACTION ARMS / POSITIONING SYSTEMS**

Torque Reaction Arms	34
Positioning Arms	36

### **SCREW FEEDERS**

NFK Screw Feeders	38
-------------------	----

### **ACCESSORIES**

FAB & RAF Series	40
KBL Series	41
PLUTO Series	42
PLUTO CA Series	43
MITO & NATO Series	44
Control Units	45



# Kolver's History

30 years of success

KOLVER® is a global leader in the market of industrial electric screwdrivers. Founded in 1989, KOLVER® has built a reputation for providing top-notch products alongside exceptional customer support. Thousands of state-of-the-art drivers are produced every year at our production hub in Italy and then shipped to over 50 countries worldwide. Product innovation, a strong commitment to sustainability and well-being, and fast and reliable service have been the keys to KOLVER's success.

Simple, accurate, cost effective, their design was so good they are still popular.



**FAB & RAF Series reach the market**

**1989**

**1998**

Our famous PLUTO Series was launched in 2000 and since then it has been often imitated, but never duplicated.



**PLUTO Screwdrivers set a new standard**

The introduction of our K-DUCER line marks a turning point - fully Industry-4.0 ready, the K-DUCER represents the new generation of precision fastening.



**K-DUCER: raising the bar-**

**2011**

**2024**

**1992**

**2000**

**2019**

**Kolver: a star is born**



At the time Kolver was founded, the market was dominated by air tools. Few people believed in electric tools – we went all in.

**A Year of Firsts**



**The first ISO9000 Certification**

The first electric screwdriver manufacturing company to be certified.

**The first ESD-safe driver in the world**

We were the first and remained unequalled in the market for 4 years.

**The MITO Range joins the family**



Specifically designed for high-precision applications, MITO tools were born to guarantee the same flexibility of current-controlled screwdrivers even on low torques.

**The K-TESTER is here**



Our new K-TESTER paves the way for the future of torque measurement.



# KOLVER®: MORE QUALITY THAN YOU MAY EVER NEED

You've got an assembly job to do, and there are a lot of people counting on you to get it done right. At KOLVER®, we know what you are looking for.

We deliver the most innovative and cost-effective electric fastening systems in the industry and that's why our tools have countless happy users and... pale imitators worldwide!

KOLVER® solutions represent the true answer to your assembly needs.

ISO 9001 certified since 1998, Kolver's mission has always been to fulfill customers' expectations, delivering the right quality products at the right time, at the right price.

About 50% of the products in our catalogue have been launched or upgraded during the last 3 years.

Clutch tools, current-control tools, transducerized tools: inline, pistol, angle and fix-tured, along with controllers and software in an outstanding combination of ergonomics, performance, error proofing and durability.

SERIES	CLUTCH TOOLS	TORQUE & ANGLE CURRENT CONTROL	TORQUE & ANGLE TRANSDUCERIZED	TORQUE RANGE Nm	TORQUE RANGE in.lbs
FAB	•			0.05-1.8	0.44-15.9
RAF	•			0.7-5.0	6.2-44.25
KBL	•			0.04-4.0	0.35-35.4
ACC	•			0.2-4.5	1.77-39.8
NATO		•		0.01-0.5	0.09-4.4
MITO		•		0.2-1.5	1.8-13.3
PLUTO		•		0.5-75	4.4-664
KDS			•	0.05-70	0.44-620

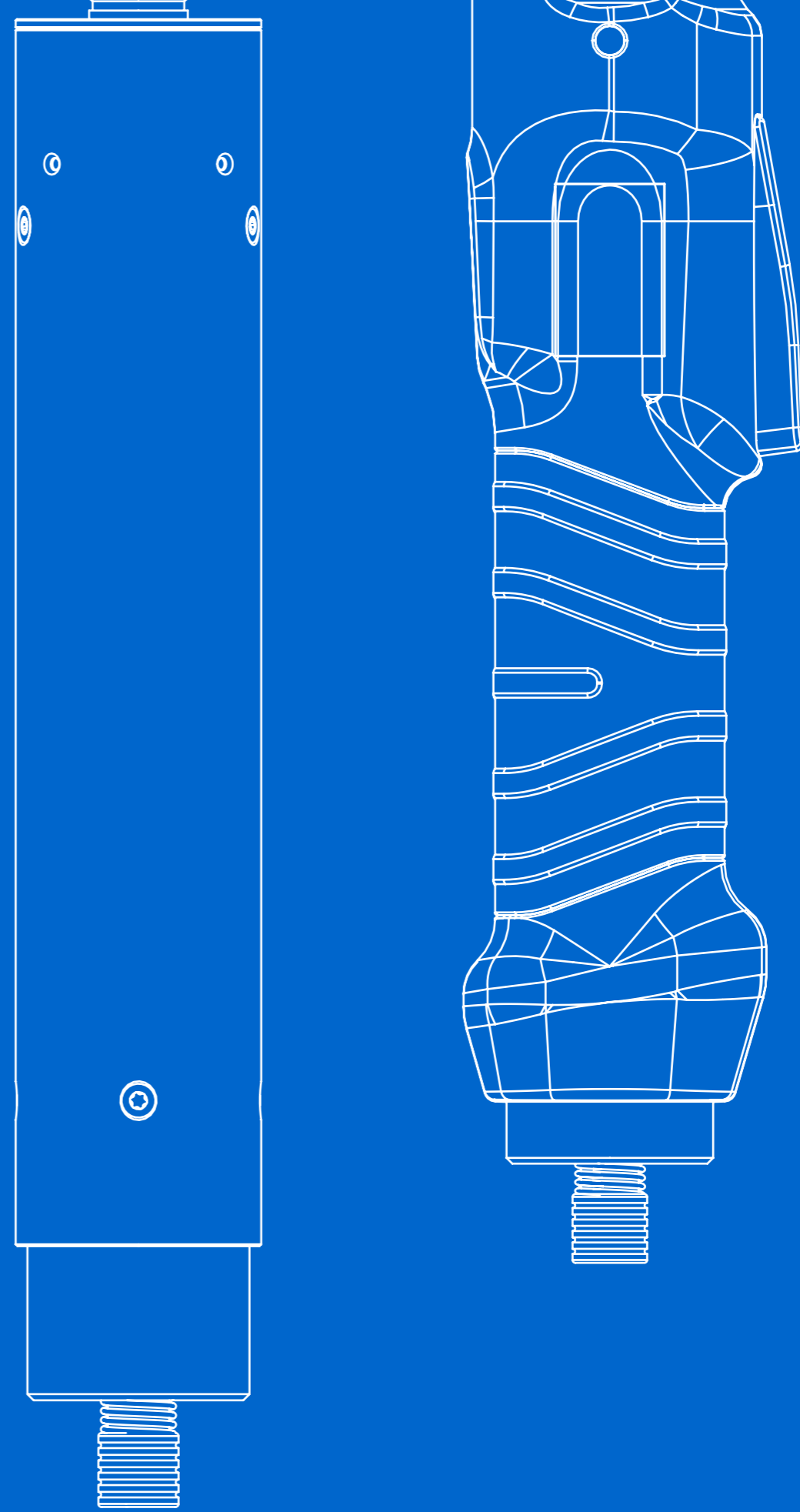

TRANSDUCERIZED SCREWDRIVERS



## KDS Hand-held Screwdrivers | Torque range 0.44 – 620 lbf-in

The K-DUCER is our A-class intelligent transducerized assembly system. The system consists of an advanced state-of-the-art controller and a range of handheld and fixtured electric screwdrivers with torque up to 620 lbf-in.

### Finest accuracy and precision

KDS transducerized electric tools cover all assembly line requirements for an accurate, high-quality torque and angle-controlled tightening experience.

A built-in compact torque transducer provides closed-loop control with excellent repeatability.

### Excellent ergonomics

KDS screwdrivers feature unsurpassed ergonomics, soft touch design, status LED, temperature protection combined with full traceability and error-proofing capabilities.

Available in straight, pistol and fixture configuration (see page 10 for further information).

### Connectivity and Industry 4.0

KDS tools are the ideal solution for your Industry 4.0 production line. Integrating the K-Ducer in your smart factory will be effortless, thanks to the built-in Modbus TCP and Open Protocol connectivity.

Built-in LED lights provide immediate feedback on each tightening process, i.e. you'll be able to check at a glance whether the part is correctly tightened or not.

KDS screwdrivers work in combination with KDU control units to gather, analyse and process detailed assembly information.

Their built-in transducer continuously reads torque and position of the screw and sends the gathered data to the KDU controller for analysis.

### Available Housings



INLINE (KDS-PL/ESD) – Inline versions available in lever start. ESD-safe. KDS inline screwdrivers can also be supplied with built-in LED lights (KDS-PL /LED/ESD), which light up the area underneath while in use.



PISTOL GRIP – Trigger start, pistol grip available with top connector (KDS-PL P/U/ESD) or bottom connector (KDS-PL P/ESD). ESD-safe.



ALUMINIUM HOUSING (KDS-PL) For torques over 177 lbf-in, with start and reverse buttons.



ANGLE MODELS (KDS-PL ANG/ESD) Inline models with angle head attached. ESD-safe.



### Inline KDS Screwdrivers

Code	Model	Torque lbf-in	RPM min-max	Dimensions in	Weight lb	Bit Drive
165050	KDS-NT70	0.44 - 6.19	20 - 700	8.8 x 1	0.7	Hex 1/4"
165050/HM	KDS-NT70/HM	0.44 - 6.19	20 - 700	8.8 x 1	0.7	Half moon 4 mm
175015/ESD	KDS-MT1.5/ESD	0.9 - 13.3	50 - 850	10 x 1.6	1.5	Hex 1/4"
135006/ESD	KDS-PL6/ESD	4.42 - 53	50 - 850	9.9 x 1.6	1.5	Hex 1/4"
135010/ESD	KDS-PL10/ESD	7.1 - 88.5	50 - 600	9.9 x 1.6	1.5	Hex 1/4"
135015/ESD	KDS-PL15/ESD	4.42 - 133	50 - 320	9.9 x 1.6	1.5	Hex 1/4"
135020	KDS-PL20	17.7 - 177	10 - 210	11.7 x 1.9	2.9	Sq 3/8"
135035	KDS-PL35	26.6 - 310	10 - 140	12.5 x 1.7	3.9	Sq 3/8"
135050	KDS-PL50	44.3 - 443	10 - 90	12.7 x 1.7	3.9	Sq 1/2"

### Inline KDS Screwdrivers with front LED lights

Code	Model	Torque lbf-in	RPM min-max	Dimensions in	Weight lb	Bit Drive
175015/LED/ESD	KDS-MT1.5/LED/ESD	0.9 - 13.3	50 - 850	10 x 1.6	1.5	Hex 1/4"
135006/LED/ESD	KDS-PL6/LED/ESD	4.42 - 53	50 - 850	9.9 x 1.6	1.5	Hex 1/4"
135010/LED/ESD	KDS-PL10/LED/ESD	7.1 - 88.5	50 - 600	9.9 x 1.6	1.5	Hex 1/4"
135015/LED/ESD	KDS-PL15/LED/ESD	4.42 - 133	50 - 320	9.9 x 1.6	1.5	Hex 1/4"

### Pistol grip KDS Screwdrivers with bottom connector

Code	Model	Torque lbf-in	RPM min-max	Dimensions in	Weight lb	Bit Drive
175016/ESD	KDS-MT1.5P/ESD	0.9 - 13.3	50 - 850	7.3 x 6.8 x 2	1.5	Hex 1/4"
135007/ESD	KDS-PL6P/ESD	4.42 - 53	50 - 850	7.3 x 6.7 x 2	1.5	Hex 1/4"
135011/ESD	KDS-PL10P/ESD	7.1 - 88.5	50 - 600	7.3 x 6.7 x 2	1.5	Hex 1/4"
135016/ESD	KDS-PL15P/ESD	4.42 - 133	50 - 320	7.3 x 6.7 x 2	1.5	Hex 1/4"

### Pistol grip KDS Screwdrivers with top connector

Code	Model	Torque lbf-in	RPM min-max	Dimensions in	Weight lb	Bit Drive
175016/U/ESD	KDS-MT1.5P/U/ESD	0.9 - 13.3	50 - 850	7.3 x 6.8 x 2	1.5	Hex 1/4"
135007/U/ESD	KDS-PL6P/U/ESD	4.42 - 53	50 - 850	7.3 x 6.7 x 2	1.5	Hex 1/4"
135011/U/ESD	KDS-PL10P/U/ESD	7.1 - 88.5	50 - 600	7.3 x 6.7 x 2	1.5	Hex 1/4"
135016/U/ESD	KDS-PL15P/U/ESD	4.42 - 133	50 - 320	7.3 x 6.7 x 2	1.5	Hex 1/4"

### Angle head KDS Screwdrivers

Code	Model	Torque lbf-in	RPM min-max	Dimensions in	Weight lb	Bit Drive
175015/A/ESD	KDS-MT1.5ANG	0.9 - 13.3	50 - 850	11.3 x 1.6	1.5	Hex 1/4"
135006/A/ESD	KDS-PL6/ANG	4.42 - 48.7	50 - 850	11.3 x 1.6	1.5	Hex 1/4"
135010/A/ESD	KDS-PL10/ANG	7.1 - 80	50 - 600	11.3 x 1.6	1.5	Hex 1/4"
135015/A	KDS-PL15/ANG	4.42 - 106	50 - 320	12.8 x 1.6	1.9	Sq 3/8"
135015/A/1-4/ESD	KDS-PL15/ANG/1-4/ESD	4.42 - 106	50 - 320	12.8 x 1.6	1.9	Hex 1/4"
135030/A	KDS-PL30ANG	26.6 - 266	10 - 140	16.9 x 1.7	4.6	Sq 3/8"
135045/A	KDS-PL45ANG	35.4 - 398	10 - 90	17.7 x 1.7	6.2	Sq 1/2"
135070/A	KDS-PL70ANG	62 - 620	10 - 50	17.8 x 1.7	6.2	Sq 1/2"

2D and 3D drawings available on [kolver.com](http://kolver.com) // **IMPORTANT: Continuous use over 80% of torque range is not recommended.**

KDS Screwdrivers work in combination with KDU series controllers. See page 12 for further information. All KDS Screwdrivers

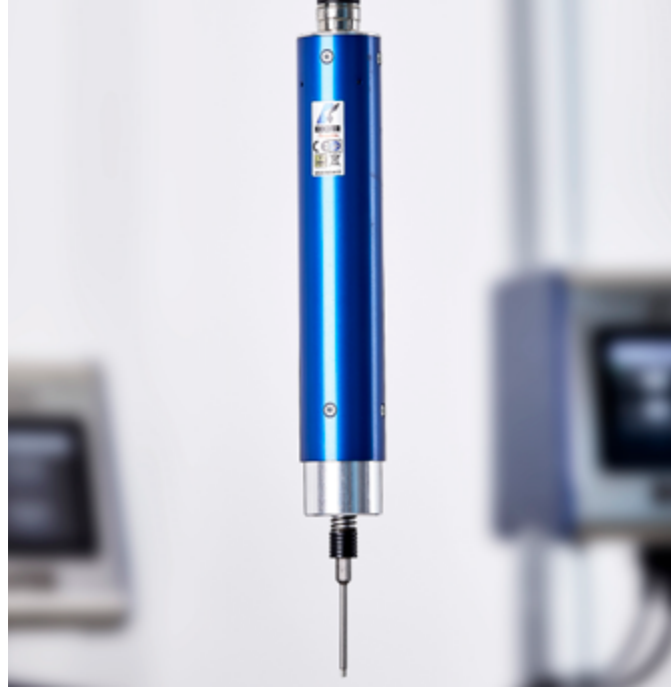

## KDS Screwdrivers for Automation | Torque range 0.44 – 443 in-lb

The KDS CA screwdrivers are part of the K-DUCER series for automated applications. They are the ideal solution for assembly lines with robots or any other machine requiring Industry 4.0 standards. The torque range covers 0.44 - 443 in-lb.

### Excellent precision and accuracy

KDS transducerized screwdrivers are designed to ensure a high-quality torque and angle-controlled tightening experience. The built-in transducer and torque-angle feature guarantee maximum precision and accuracy.

### Perfect for automatic machines

KDS CA transducerized screwdrivers are very easy to install on robots, automatic machines and autofeeding systems. KDS CA/FN models are supplied with flange and telescopic spindle specifically designed for demanding applications. Models with 90° angle heads for hard-to-reach screws are also available.

### Designed for Industry 4.0

The K-Ducer series screwdrivers guarantee total traceability, according to Industry 4.0 standards. Their built-in LED signals provide immediate feedback on each tightening process. KDS screwdrivers work in combination with KDU control units to collect and analyse detailed assembly information. Integrating the K-Ducer in your smart factory will be effortless, thanks to the built-in Modbus TCP and Open Protocol connectivity. The built-in transducer continuously reads torque and screw position and sends the collected data to the KDU control unit for analysis (more information on KDU features on page 12).

### Available housings

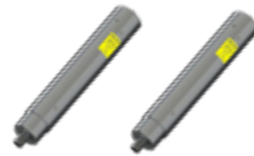

ALUMINIUM BODY (KDS-PL CA) – Specifically designed for automation. Easy to install on any machine or robot.

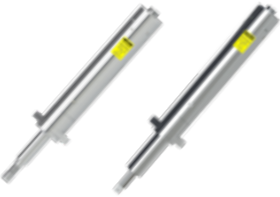

ALUMINIUM BODY WITH FLANGE MOUNT (KDS-PL CA/FN) – Ideal for automated high volume/high duty applications. Flange and telescopic spindle available together or separately.

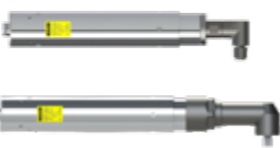

ANGLE MODELS (KDS-PL CA/ANG) Models for automation, with angle head attached for hard-to-reach screws.



### Aluminium housing KDS Screwdrivers

Code	Model	Torque lbf-in	RPM min-max	Dimensions in	Weight lb	Bit Drive
165150	KDS-NT70CA	0.44 - 6.19	20 - 700	8.9 x 1	0.7	Hex 1/4"
165150/HM	KDS-NT70CA/HM	0.44 - 6.19	20 - 700	8.9 x 1	0.7	Half moon 0.16 in
175115	KDS-MT1.5CA	0.9 - 13.3	50 - 850	10 x 1.6	1.9	Hex 1/4"
135106	KDS-PL6CA	4.42 - 53	50 - 850	9.8 x 1.6	1.9	Hex 1/4"
135110	KDS-PL10CA	7.1 - 88.5	50 - 600	9.8 x 1.6	1.9	Hex 1/4"
135115	KDS-PL15CA	4.42 - 133	50 - 320	9.8 x 1.6	1.9	Hex 1/4"
135120	KDS-PL20CA	17.7 - 177	10 - 210	11.7 x 1.9	2.9	Sq 3/8"
135135	KDS-PL35CA	26.6 - 310	10 - 140	12.5 x 2.2	3.9	Sq 3/8"
135150	KDS-PL50CA	44.3 - 443	10 - 90	12.7 x 2.2	3.9	Sq 1/2"

### Aluminium housing KDS Screwdrivers with flange mount

Code	Model	Torque lbf-in	RPM min-max	Dimensions in	Weight lb	Bit Drive
175115/FN	KDS-MT1.5CA/FN	0.9 - 13.3	50 - 850	12.4 x 1.6	2.4	Hex 1/4"
135106/FN	KDS-PL6CA/FN	4.42 - 53	50 - 850	13.8 x 1.6	2.4	Sq 3/8"
135110/FN	KDS-PL10CA/FN	7.1 - 88.5	50 - 600	13.8 x 1.6	2.4	Sq 3/8"
135115/FN	KDS-PL15CA/FN	4.42 - 133	50 - 320	13.8 x 1.6	2.4	Sq 3/8"
135120/FN	KDS-PL20CA/FN	17.7 - 177	10 - 210	15.1 x 1.9	3.5	Sq 3/8"
135135/FN	KDS-PL35CA/FN	26.6 - 310	10 - 140	16.1 x 2.2	4.6	Sq 3/8"
135150/FN	KDS-PL50CA/FN	44.3 - 443	10 - 90	16.5 x 1.7	5.1	Sq 1/2"

### Aluminium housing KDS Screwdrivers with angle head

Code	Model	Torque lbf-in	RPM min-max	Dimensions in	Weight lb	Bit Drive
135106/A	KDS-PL6CA/ANG	4.42 - 48.7	50 - 850	11 x 1.6	1.5	Hex 1/4"
135110/A	KDS-PL10CA/ANG	7.1 - 80	50 - 600	11 x 1.6	1.5	Hex 1/4"
135115/A	KDS-PL15CA/ANG	4.42 - 106	50 - 320	11 x 1.6	1.9	Hex 1/4"

2D and 3D drawings available on [kolver.com](http://kolver.com) // **IMPORTANT: Continuous use over 80% of torque range is not recommended.**

KDS Screwdrivers work in combination with KDU series controllers. See page 12 for further information.



### KDU Controllers | K-Ducer Power Units

The KDU Series of controllers give you full control of your fastening operation in an industry leading compact size.

#### Features

With features like touch screen color display, multiple programs and sequences, intuitive programming interface, torque and angle control and graphs output, the KDU-1A and KDU-NT units provide unmatched performance and value. KDU controllers will operate all KDS series of tools.

#### Easy to use

Set-up and operation are really an easy task. Units may be programmed either through the touch screen or via our free K-Expand PC software, which also features data acquisition and statistical process control functionality.

#### Connectivity and Industry 4.0

Industry 4.0 – The Fourth Industrial Revolution – is driving the evolution of the assembly process. The digitalization of manufacturing and assembly means shifting the way we look at manufacturing in terms of production optimization and automation.

KDU-1A advanced controllers feature Modbus TCP and Open Protocol connectivity through a built-in ethernet port. Most other industrial communication protocols are also available with the support of external modules.

The more informed you are, the better decisions you can make. Having smart tools on your line means that you have specific tightening information fed into the production system – information concerning critical details of your components, materials and tightening process. This provides a valuable opportunity to increase efficiency and results in pro-active problem solving, alongside with considerable energy savings from efficiency improvements.

#### KDU control units

Code	Model	Description	Weight lb	Dimensions in
035001/A	KDU-1A	For KDS (non-NT)	5.5	7.5 x 8.1 x 4.7
033001	KDU-NT	For KDS-NT	3.3	7.2 x 6.7 x 2.7

#### Optional supports

A table stand or wall mount are available for KDU units. Wall mounts can be easily installed on any vertical surface and allow KDU controllers to tilt up/down and left/right – place your KDU unit anywhere and adjust its position to best suit your needs. A table stand ensures quick access to cables when placing your KDU unit on a flat surface. It is the best option in case you'd like to keep your KDU controller right at hand.



Pivoting table stand

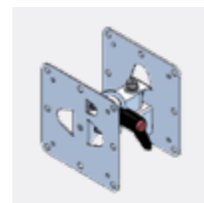

Wall bracket

#### Supports for KDU control units

Code	Model	Description
010401	Wall mount tilting bracket	For wall or column use
010402	Pivoting table stand	For table use, tiltable



Features	KDU-1A For any KDS screwdriver (except for KDS-NT)	KDU-NT For KDS-NT screwdrivers
5" Touch Screen	•	•
Programs	200	64
Sequences	24	8
Input NPN	20	4
Outputs	21	4
Torque & angle control	•	•
Real-time Torque graph	•	•
Bar code reading, linear and 2D	•	•
Multiple parameters	•	•
Prevailing Torque Monitoring & Compensation	•	•
Mini USB	•	•
USB Data Collection	•	•
Modbus TCP	•	•
Open Protocol	•	•
RS 232 (2)	•	•
Industrial Protocols Support	•	•

### KOLVER® EXCLUSIVE

Kolver's unique DOCK05 (code 020046) makes it possible to use two KDS screwdrivers with just one KDU-1A control unit – this means you can cut costs dramatically by purchasing one control unit instead of two.

Whenever two KDS screwdrivers are meant to be used one at a time, a DOCK05 is the best solution to maximize productivity at the lowest possible cost.

- Unique product – the first ever double output connector for transducerized tools in the market.
- Cut K-Ducer purchase costs by 40%.
- Fully compatible with KDU-1A – get the most out of your K-Ducer system.
- Instant tool recognition.
- Assign any KDU program or sequence to either screwdriver.

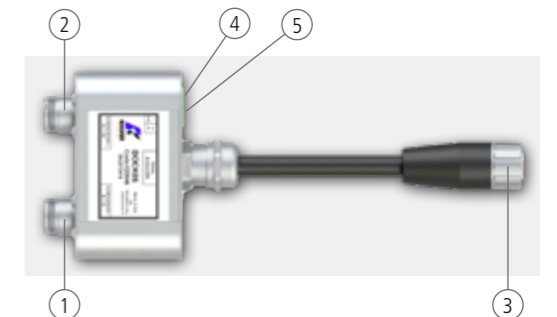

(1) KDS Screwdriver #1 (2) KDS Screwdriver #2 (3) KDU Control unit (4) Pin GND (5) Pin IN



### Cables | K-Ducer Screwdrivers and Control Units

Cables are required to complete any K-Ducer system, as they connect KDS screwdrivers to KDU control units. They're made of sturdy materials to guarantee exceptional resistance to wear and tear. Also, they're superquick to connect thanks to their one-click connector. Two different lengths (98 in and 197 in) are available to meet any production requirement.

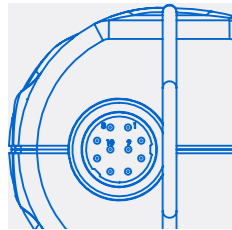

Driver connector (KDS view)

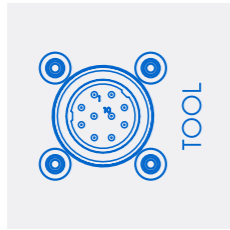

Unit connector (KDU view)

#### Cables to connect KDS screwdrivers to KDU units

Code	Model	Description
250363	Cable 8ft for KDS-NT	8pin 8ft
250363/5	Cable 15ft for KDS-NT	8pin 15ft
250064	Cable 8ft	M16 10pin 8ft
250064/H	Cable 8ft, heavy duty	M16 10pin 8ft
250064/A	Cable 8ft, 90°, heavy duty	M16 10pin 8ft
250564	Cable 15ft	M16 10pin 15ft
250564/H	Cable 15ft, heavy duty	M16 10pin 15ft
250564/A	Cable 15ft, 90°, heavy duty	M16 10pin 15ft
250564/HS	Cable 15ft, spiral, heavy duty	M16 10pin 15ft
250764	Cable 21ft, heavy duty	M16 10pin 21ft

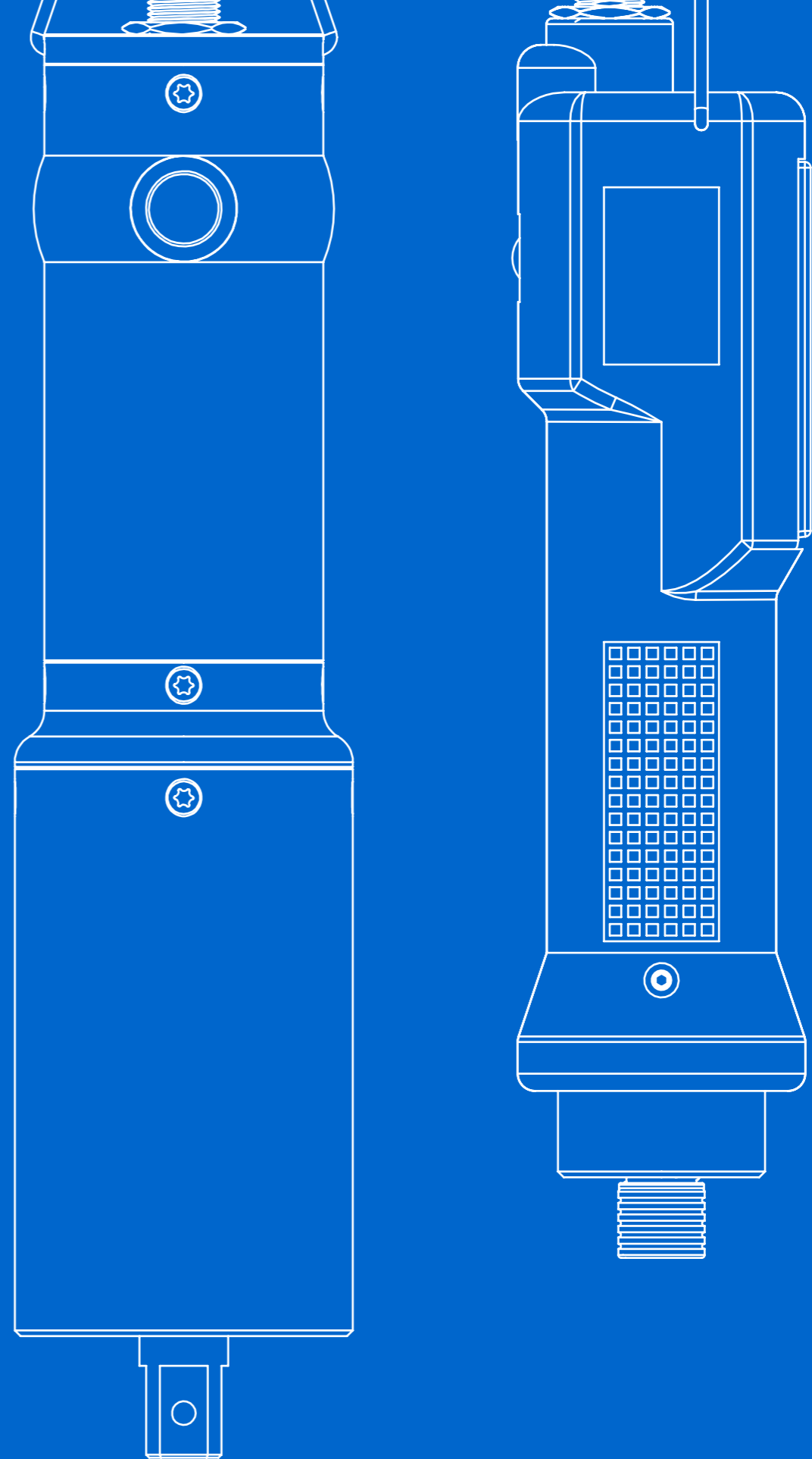





# THE BENEFITS OF CURRENT-CONTROLLED SCREWDRIVERS

The PLUTO, MITO & NATO screwdriver family is the most advanced current-controlled tightening solution for torque applications up to 620 lbf-in and as low as 0.2 lbf-in.

Extremely ergonomic, compact and full of functionalities, it is the right tool to boost productivity, resulting in high efficiency and cost reduction.

Our current-controlled system is flexible and provides clear operator feedback.

All PLUTO, MITO & NATO screwdrivers are ESD (electrostatic discharge) approved to guarantee the best quality, no matter the requirement of the surroundings.

## KOLVER's Current-controlled solution means:

- High accuracy, normally better than  $\pm 10\%$ , Cmk always better than 1.66
- Torque & angle control and monitoring
- Ergonomic and lightweight design
- Multiple communication ports

## Benefits of KOLVER's current-controlled tools:

- The best price-to-quality ratio
- Superior product quality
- Direct error detection and error proofing
- Reduction of incorrectly-tightened screws and stripped joints
- Improved process control and reduced setup time
- Industry 4.0 ready



## PLUTO, MITO and NATO | Torque range 0.18 – 620 lbf-in

Our PLUTO, MITO and NATO screwdrivers offer high-precision at a competitive price, with a repeatability of  $\pm 5\%$ . Pick the one that best suits your application among the many current-controlled models ranging in torque from 0.18 lbf-in all the way up to 620 lbf-in.

### Extremely versatile

Our PLUTO® Series screwdrivers feature a wide torque range: starting at 4.4 lbf-in with PLUTO3, they reach up to 620 lbf-in with PLUTO70ANG. Also, you can handle up to 8 different joints by connecting your PLUTO screwdriver to one of our EDU2AE/TOP multiprogram control units.

### Precise low-torque screwdrivers

The NATO and MITO series are the ideal solution for high-precision low torques below 13 lbf-in. MITO tools operate within a torque range of 3 – 13 lbf-in, while NATO screwdrivers are designed for an even lower torque range of 0.2 – 4.4 lbf-in.

### Long-lasting accuracy

PLUTO, MITO and NATO drivers feature an innovative coreless motor coupled with planetary gearboxes, producing extremely low inertia and minimal friction for long life and very accurate torque production.

### Torque/Angle Control

The main parameters to be controlled are the tightening torque and the rotation angle of the screw, either with torque or angle priority. The screwdriver stops automatically when the pre-set angle and torque value have been reached and an indication of OK cycle (green led turned on) is given, otherwise a red led turns on if the tightened screw doesn't match the pre-set parameters. The final torque and angle values are also displayed.

### Compact ergonomic design

All PLUTO, MITO and NATO screwdrivers feature an ESD-safe housing, either in hand-held option or aluminium body for automation. PLUTO and MITO drivers are available in pistol or inline style, catering to operator preference and comfort. NATO drivers are inline style, with a lever start actuation. Foot pedals are available in cases where the operator would like the convenience of manual operation with the NATO/CA series.

### Available Housings



INLINE (PLUTO D, MITO D & NATO D) – Inline versions available in lever start, current-controlled style. PLUTO D available with reduced front ring upon request.



PISTOL GRIP – Trigger start, pistol grip available with top connector (PLUTO P/U and MITO 15P/U) or bottom connector (PLUTO P and MITO 15P).



ALUMINIUM BODY (PLUTO CA/SR, MITO CA and NATO CA) – PLUTO with start and reverse buttons. MITO and NATO they can also be used with foot pedals for manual operations. MITO also available with flange mount



ANGLE MODELS (PLUTO .ANG) – Inline models with angle head attached. Current-controlled style. Wrench blade attachments available upon request.





Inline Screwdrivers

Code	Model	Torque lbf-in	RPM min-max	Dimensions in	Weight lb	Bit Drive
170015	MITO15D	2.5 - 13.3	450 - 850	8.5 x 1.3	0.8	Hex 1/4"
130203	PLUTO3D	4.4 - 22.1	370 - 1300	8.9 x 1.6	1.1	Hex 1/4"
130206	PLUTO6D	7.5 - 53.1	200 - 850	8.9 x 1.6	1.1	Hex 1/4"
130211/N	PLUTO10D/N	13.3 - 88.5	110 - 600	8.9 x 1.6	1.1	Hex 1/4"
130216/N	PLUTO15D/N	17.7 - 133	60 - 320	8.9 x 1.6	1.3	Hex 1/4"

Pistol grip Screwdrivers

Code	Model	Torque lbf-in	RPM min-max	Dimensions in	Weight lb	Connector Option
170014	MITO15P	2.5 - 13.3	450 - 850	7.6 x 6.3 x 1.8	1.1	Bottom connector
170014/U	MITO15P/U	2.5 - 13.3	450 - 850	7.7 x 6.3 x 1.8	1.1	Top connector
130204	PLUTO3P	4.4 - 22.1	370 - 1300	6.3 x 6.9 x 1.8	1.1	Bottom connector
130205	PLUTO3P/U	4.4 - 22.1	370 - 1300	6.4 x 6.9 x 1.8	1.1	Top connector
130207	PLUTO6P	7.5 - 53.1	200 - 850	6.3 x 6.9 x 1.8	1.1	Bottom connector
130207/U	PLUTO6P/U	7.5 - 53.1	200 - 850	6.4 x 6.9 x 1.8	1.1	Top connector
130210/N	PLUTO10P/N	13.3 - 88.5	110 - 600	6.3 x 6.9 x 1.8	1.1	Bottom connector
130210/U/N	PLUTO10P/U/N	13.3 - 88.5	110 - 600	6.4 x 6.9 x 1.8	1.1	Top connector
130215/N	PLUTO15P/N	17.7 - 133	60 - 320	6.3 x 6.9 x 1.8	1.1	Bottom connector
130215/U/N	PLUTO15P/U/N	17.7 - 133	60 - 320	6.4 x 6.9 x 1.8	1.1	Top connector

Aluminium body Screwdrivers

Code	Model	Torque lbf-in	RPM min-max	Dimensions in	Weight lb	Bit Drive
170016	MITO15CA	2.5 - 13.3	450 - 850	7.6 x 1.3	0.8	Hex 1/4"
170016/FN	MITO15CA/FN	2.5 - 13.3	450 - 850	10.7 x 1.3	2.9	Hex 1/4"
133221/SR	PLUTO20CA/SR	26.6 - 177	50 - 200	9.1 x 2.1	2.4	Sq 3/8"
133236/SR	PLUTO35CA/SR	26.6 - 310	40 - 140	9.7 x 2.2	3.3	Sq 3/8"
133250/SR	PLUTO50CA/SR	44.3 - 443	20 - 90	9.9 x 2.2	3.3	Sq 1/2"

Angle head PLUTO Screwdrivers

Code	Model	Torque lbf-in	RPM min-max	Dimensions in	Bit Drive	Start Option
130203/A	PLUTO3ANG	4.4 - 22	370 - 1300	11.3 x 1.6	Hex 1/4"	Lever start
130206/A	PLUTO6ANG	7.5 - 53	200 - 850	11.3 x 1.6	Hex 1/4"	Lever start
130208	PLUTO8ANG	13.3 - 70.8	110 - 600	11.3 x 1.6	Hex 1/4"	Lever start
130216/A	PLUTO15ANG	17.7 - 115	100 - 320	11.9 x 1.6	Sq 3/8"	Lever start
133220	PLUTO20ANG	26.6 - 159	60 - 200	11.9 x 2.1	Sq 3/8"	Start/Reverse Buttons
133231	PLUTO30ANG	53 - 265	30 - 130	17.1 x 2.1	Sq 3/8"	Start/Reverse Buttons
133245	PLUTO45ANG	39 - 398	20 - 90	17.5 x 2.2	Sq 1/2"	Start/Reverse Buttons
133270	PLUTO70ANG	133 - 620	20 - 50	18 x 2.2	Sq 1/2"	Start/Reverse Buttons

Control units

Code	Model	Single Program	Torque Value in lbf-in	Serial Port	Multitorque (8 P-sets)	USB Port	PC Software	Weight lb	Dimensions in
032000/HPRO	EDU2AE/HPRO	•	•	•	-	-	-	5.3	7.7 x 6.7 x 4.3
032000/TOP/E	EDU2AE/TOP/E	-	•	•	•	•	•	5.5	7.5 x 8.1 x 4.7

See page 21 for a complete list of features.

2D and 3D drawings available on kolver.com

IMPORTANT: Continuous use over 80% of torque range is not recommended.



Inline TA Screwdrivers

Code	Model	Torque lbf-in	RPM min-max	Dimensions in	Weight lb	Bit Drive
160015/TA	NATO15D/TA	0.18 - 2.4	100 - 700	8.3 x 1.3	0.5	Half moon 0.16 in
160050/TA	NATO50D/TA	0.4 - 4.4	50 - 700	8.3 x 1.3	0.5	Hex 1/4"
170015/TA	MITO15D/TA	2.5 - 13.3	450 - 850	8.5 x 1.3	0.8	Hex 1/4"
134203/TA	PLUTO3D/TA	4.4 - 22.1	370 - 1300	8.9 x 1.6	1.1	Hex 1/4"
134206/TA	PLUTO6D/TA	7.5 - 53.1	200 - 850	8.9 x 1.6	1.1	Hex 1/4"
134211/TA	PLUTO10D/TA	13.3 - 88.5	110 - 600	8.9 x 1.6	1.1	Hex 1/4"
134216/TA	PLUTO15D/TA	17.7 - 133	60 - 320	8.9 x 1.6	1.1	Hex 1/4"

Models with LED light ring

134203/TA/LED	PLUTO3D/TA/LED	4.4 - 22.1	370 - 1300	8.9 x 1.6	1.1	Hex 1/4"
134206/TA/LED	PLUTO6D/TA/LED	7.5 - 53.1	200 - 850	8.9 x 1.6	1.1	Hex 1/4"
134211/TA/LED	PLUTO10D/TA/LED	13.3 - 88.5	110 - 600	8.9 x 1.6	1.1	Hex 1/4"
134216/TA/LED	PLUTO15D/TA/LED	17.7 - 133	60 - 320	8.9 x 1.6	1.1	Hex 1/4"

Pistol grip TA Screwdrivers

Code	Model	Torque lbf-in	RPM min-max	Dimensions in	Weight lb	Connector Option
130204/TA	PLUTO3P/TA	4.4 - 22.1	370 - 1300	6.3 x 6.9 x 1.8	1.1	Bottom connector
130205/TA	PLUTO3P/U/TA	4.4 - 22.1	370 - 1300	6.4 x 6.9 x 1.8	1.1	Top connector
130207/TA	PLUTO6P/TA	7.5 - 53.1	200 - 850	6.3 x 6.9 x 1.8	1.1	Bottom connector
130207/U/TA	PLUTO6P/U/TA	7.5 - 53.1	200 - 850	6.4 x 6.9 x 1.8	1.1	Top connector
130210/TA	PLUTO10P/TA	13.3 - 88.5	110 - 600	6.3 x 6.9 x 1.8	1.1	Bottom connector
130210/U/TA	PLUTO10P/U/TA	13.3 - 88.5	110 - 600	6.4 x 6.9 x 1.8	1.1	Top connector
130215/TA	PLUTO15P/TA	17.7 - 133	60 - 320	6.3 x 6.9 x 1.8	1.3	Bottom connector
130215/U/TA	PLUTO15P/U/TA	17.7 - 133	60 - 320	6.4 x 6.9 x 1.8	1.3	Top connector

Aluminium body TA Screwdrivers

Code	Model	Torque lbf-in	RPM min-max	Dimensions in	Weight lb	Bit Drive
163015/TA	NATO15CA/TA	0.18 - 2.4	100 - 700	5.9 x 2.2	0.4	Half moon 0.16 in
163050/TA	NATO50CA/TA	0.4 - 4.4	50 - 700	5.9 x 2.2	0.4	Hex 1/4"
133221/SR/TA	PLUTO20CA/SR/TA	26.6 - 177	50 - 200	9.1 x 2.1	2.4	Sq 3/8"
133236/SR/TA	PLUTO35CA/SR/TA	26.6 - 310	40 - 140	9.7 x 2.2	3.3	Sq 3/8"
133250/SR/TA	PLUTO50CA/SR/TA	44.3 - 443	20 - 90	9.9 x 2.2	3.3	Sq 1/2"

Angle head TA Screwdrivers

Code	Model	Torque lbf-in	RPM min-max	Dimensions in	Bit Drive	Start Option
130203/A/TA	PLUTO3ANG/TA	4.4 - 22	370 - 1300	11.9 x 1.6	Hex 1/4"	Lever start
130206/A/TA	PLUTO6ANG/TA	7.5 - 53	200 - 850	11.9 x 1.6	Hex 1/4"	Lever start
130208/TA	PLUTO8ANG/TA	13.3 - 70.8	110 - 600	11.9 x 1.6	Hex 1/4"	Lever start
130216/A/TA	PLUTO15ANG/TA	17.7 - 115	100 - 320	11.9 x 1.6	Hex 1/4"	Lever start

Control units for TA Screwdrivers

Code	Model	NATO TA Series	PLUTO, MITO TA Series	Serial Port	Multitorque (8 P-sets)	Computer Interface	Torque & Angle	Weight lb	Dimensions in
031000/TOP/NT/TA	EDU2AE/TOP/NT/TA	•	-	•	•	•	•	4.4	7.5 x 8.1 x 4.7
034000/TOP/TA	EDU2AE/TOP/TA	-	•	•	•	•	•	2.50	190 x 205 x 120

See page 21 for a complete list of features.

2D and 3D drawings available on kolver.com

IMPORTANT: Continuous use over 80% of torque range is not recommended.



## EDU2AE Control Units | For PLUTO, MITO and NATO Screwdrivers

EDU2AE control units are meant to be used in combination with Kolver® current controlled PLUTO, MITO and NATO screwdrivers. EDU2AE series switching controllers act as an AC to DC transformer and torque controller. The electronic control circuit cuts the power supply to the motor as soon as the pre-set torque has been reached.

### Universal usage

All units are equipped with a high power switching transformer with 90-260 V AC power supply for universal usage. EDU2AE control units are multilanguage: you can choose among English, Italian, German, French, Portuguese or Spanish.

### Single & Multi-Torque

Choose the control unit that best suits your requirements among our single-torque controllers or multi-torque. Multi-torque control units are designed to expand the functionality of current-controlled screwdrivers by enabling multiple torque settings (up to 8) using one controller and one driver.

### Extremely accurate

Thanks to the latest state-of-the-art advanced software for torque controlling it is now possible to reach the most accurate results with CM / CMK values higher than ever. The combination of the software and switching transformer allows these screwdrivers to reach a +/- 5% precision all over the torque range.

### Better endurance

All units comply to norms 61000-6-2 and 61000-6-3, and therefore have better endurance in environments with high noise and interference levels. Improved EMC features are guaranteed thanks to their solid steel base and back panel.

### Connectivity and Industry 4.0

All functions can be set and controlled via user interface screens or remotely via 15 input and 11 output connectors. A wide range of accessories for remote programming and PC interface is available for the complete EDU2AE series (see page 51). EDU2AE/TOP/E, EDU2AE/TOP/TA and EDU2AE/TOP/NT/TA come standard with the EXPAND software package to set, change and save all parameters via USB key & PC.

### EDU2AE & Screwdriver Series Combination

Control units	Screwdriver models	
<b>EDU2AE/HPRO</b> <b>EDU2AE/TOPE</b>	Hand-held	Automation
	MITO D MITO P PLUTO D, D/N PLUTO P, P/N PLUTO P/U, P/U/N PLUTO CA/SR PLUTO ANG PLUTO ANG/SR	MITO CA MITO CA/FN PLUTO CA PLUTO CA/FN PLUTO CA/FN2
<b>EDU2AE/TOP/TA</b>	Hand-held	Automation
	MITO D/TA PLUTO D/TA PLUTO D/TA/LED PLUTO P/TA PLUTO CA/SR/TA	MITO CA/TA PLUTO CA/TA PLUTO CA/FN/TA PLUTO CA/FN2/TA
<b>EDU2AE/TOP/NT/TA</b>	Hand-held	Automation
	NATO D/TA	NATO CA/TA



Features	EDU2AE/HPRO	EDU2AE/TOPE	EDU2AE/TOP/TA	EDU2AE/TOP/NT/TA
Switching power supply	•	•	•	•
Multiple Programs and Sequences		•	•	•
Time, Ramp & Speed settings	•	•	•	•
Auto and pre reverse	•	•	•	•
Settable loosening speed & torque	•	•	•	•
Prevailing torque	•	•	•	•
Clockwise/anticlockwise tightening	•	•	•	•
Password protected	•	•	•	•
Calibration	•	•	•	•
Nm - lb/in - Kgf.cm selection	•	•	•	•
Screw count	•	•	•	•
End cycle signal	•	•	•	•
Screw, Program & Sequence reset		•	•	•
Lever error	•	•	•	•
Enable/Disable loosening		•	•	•
Barcode	•	•	•	•
Serial print	•	•	•	•
Error, motor on and correct screw signals	•	•	•	•
Optional back driver connector	•			
Use with DOCK04 double connector		•	•	•
Use with PRNTR1 serial printer	•	•	•	•
Printing options for each program		•	•	•
Use with TLS1	•	•	•	•
PC programming (EDU EXPAND)		•	•	•
USB data collection		•	•	•



## Current-controlled Screwdrivers for Automation | Torque range 0.18 – 443 lbf-in

Kolver's CA screwdrivers are designed for automated and fixtured applications. Whether you're working with a robot or adapting your assembly line to Industry 4.0 standards, we have the right solution for automation in all its forms.

### Perfect for automatic machines

Our CA screwdrivers are supplied in an aluminium body for a quick and easy integration with automatic machines and screwfeeding systems. PLUTO and MITO tools in CA/FN version are equipped with a flange mount and reciprocating spindle for high volume/high duty applications.

### Robotic applications

Our CA screwdrivers can be easily interfaced with robots. The controller connects to robots to determine screw speed, torque and time out, and sends a signal to the robot when the screw reaches the specified torque.

### The Torque/Angle Models

Automation requires accurate torque controlling techniques. TA automated systems feature advanced monitoring strategies such as torque and rotation angle of the screw, for precise torque and angle control on all automated operations.

### Plenty of options

PLUTO, MITO and NATO automated torque & angle screwdrivers cover a wide torque range of 0.18-443 lbf-in; choose the tool that best suits your application! You can set 8 independent programs either directly on control unit or remotely.

### Industry 4.0

Interconnection, automatic control and continuous monitoring are fundamental aspects of Industry 4.0. Simply connect the screwdriver controller to your PLC, robot or machine through the proper connectors to manage input/output signals such as start, stop, error and more. You can also get data reports of the full tightening procedure on advanced control units like EDU2AE/TOP/E and EDU2AE/TOP/TA.

### Torque and Angle Functionality

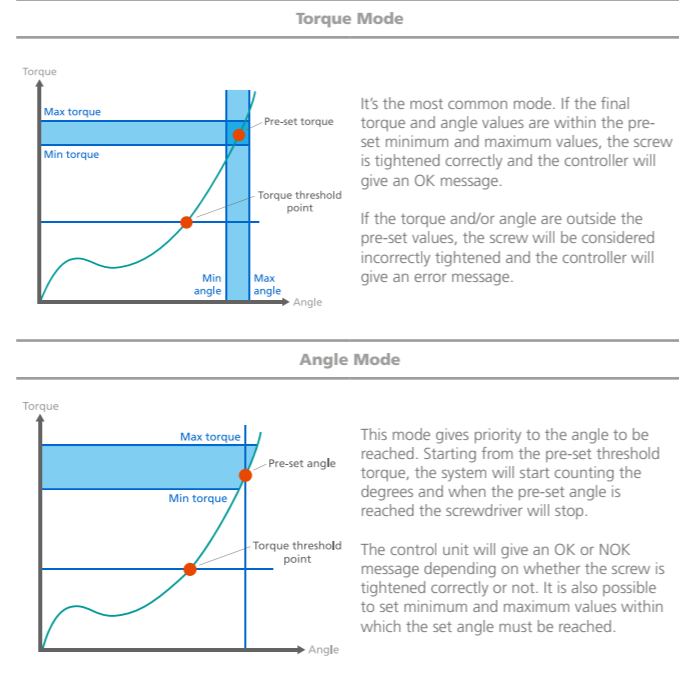

### Aluminium housing Screwdrivers

Code	Model	Torque lbf-in	RPM min-max	Dimensions in	Weight lb	Bit Drive
130303	PLUTO3CA	4.4 - 22.1	370 - 1300	6.6 x 1.6	1.1	Hex 1/4"
133206	PLUTO6CA	7.5 - 53.1	200 - 850	6.6 x 1.6	1.1	Hex 1/4"
133211/N	PLUTO10CA/N	13.3 - 88.5	110 - 600	6.6 x 1.6	1.1	Hex 1/4"
133216/N	PLUTO15CA/N	17.7 - 133	60 - 320	6.6 x 1.6	1.1	Hex 1/4"
133221	PLUTO20CA	26.6 - 177	50 - 200	9.1 x 1.9	2.4	Sq 3/8"
133236	PLUTO35CA	26.6 - 310	40 - 140	9.7 x 2.2	3.3	Sq 3/8"
133250	PLUTO50CA	44.3 - 443	20 - 90	9.9 x 2.2	3.3	Sq 1/2"

### Aluminium housing Screwdrivers with flange mount

Code	Model	Torque lbf-in	RPM min-max	Dimensions in	Weight lb	Bit Drive
130303/FN2	PLUTO3CA/FN2	4.4 - 22.1	370 - 1300	10.6 x 1.6	1.5	Sq 3/8"
130303/FN2/1-4	PLUTO3CA/FN2/1-4	4.4 - 22.1	370 - 1300	9.7 x 1.6	1.5	Hex 1/4"
133206/FN2	PLUTO6CA/FN2	7.5 - 53.1	200 - 850	10.6 x 1.6	1.5	Sq 3/8"
133206/FN2/1-4	PLUTO6CA/FN2/1-4	7.5 - 53.1	200 - 850	9.7 x 1.6	1.5	Hex 1/4"
133211/FN2	PLUTO10CA/FN2	13.3 - 88.5	110 - 600	10.6 x 1.6	1.5	Sq 3/8"
133211/FN2/1-4	PLUTO10CA/FN2/1-4	13.3 - 88.5	110 - 600	9.7 x 1.6	1.5	Hex 1/4"
133216/FN2	PLUTO15CA/FN2	17.7 - 133	60 - 320	10.6 x 1.6	1.5	Sq 3/8"
133221/FN	PLUTO20CA/FN	26.6 - 177	50 - 200	12.7 x 1.9	2.9	Sq 3/8"
133236/FN	PLUTO35CA/FN	26.6 - 310	40 - 140	13.3 x 2.2	4.3	Sq 3/8"
133250/FN	PLUTO50CA/FN	44.3 - 443	20 - 90	13.8 x 2.2	4.3	Sq 1/2"

### Aluminium housing TA Screwdrivers

Code	Model	Torque lbf-in	RPM min-max	Dimensions in	Weight lb	Bit Drive
163015/TA	NATO15CA/TA	0.18 - 2.4	100 - 700	5.9 x 2.2	0.4	Half moon 0.16 in
163050/TA	NATO50CA/TA	0.4 - 4.4	50 - 700	5.9 x 2.2	0.4	Hex 1/4"
170016/TA	MITO15CA/TA	2.5 - 13.3	450 - 850	7.6 x 2.9	0.8	Hex 1/4"
130303/TA	PLUTO3CA/TA	4.4 - 22.1	370 - 1300	6.6 x 1.6	1.1	Hex 1/4"
133206/TA	PLUTO6CA/TA	7.5 - 53.1	200 - 850	6.6 x 1.6	1.1	Hex 1/4"
133211/TA	PLUTO10CA/TA	13.3 - 88.5	110 - 600	6.6 x 1.6	1.1	Hex 1/4"
133216/TA	PLUTO15CA/TA	17.7 - 133	60 - 320	6.6 x 1.6	1.1	Hex 1/4"
133221/TA	PLUTO20CA/TA	26.6 - 177	50 - 200	9.1 x 1.9	1.5	Sq 3/8"
133236/TA	PLUTO35CA/TA	26.6 - 310	40 - 140	9.7 x 2.2	1.5	Sq 3/8"
133250/TA	PLUTO50CA/TA	44.3 - 443	20 - 90	9.9 x 2.2	1.5	Sq 1/2"

### Aluminium housing TA Screwdrivers with flange mount

Code	Model	Torque lbf-in	RPM min-max	Dimensions in	Weight lb	Bit Drive
170016/FN/TA	MITO15CA/FN/TA	2.5 - 13.3	450 - 850	10.7 x 2.9	0.8	Hex 1/4"
130303/FN2/TA	PLUTO3CA/FN2/TA	4.4 - 22.1	370 - 1300	10.6 x 1.6	1.5	Sq 3/8"
130303/FN2/TA/1-4	PLUTO3CA/FN2/TA/1-4	4.4 - 22.1	370 - 1300	9.7 x 1.6	1.5	Hex 1/4"
133206/FN2/TA	PLUTO6CA/FN2/TA	7.5 - 53.1	200 - 850	10.6 x 1.6	1.5	Sq 3/8"
133206/FN2/TA/1-4	PLUTO6CA/FN2/TA/1-4	7.5 - 53.1	200 - 850	9.7 x 1.6	1.5	Hex 1/4"
133211/FN2/TA	PLUTO10CA/FN2/TA	13.3 - 88.5	110 - 600	10.6 x 1.6	1.5	Sq 3/8"
133211/FN2/TA/1-4	PLUTO10CA/FN2/TA/1-4	13.3 - 88.5	110 - 600	9.7 x 1.6	1.5	Hex 1/4"
133216/FN2/TA	PLUTO15CA/FN2/TA	17.7 - 133	60 - 320	10.6 x 1.6	1.5	Sq 3/8"
133221/FN/TA	PLUTO20CA/FN/TA	26.6 - 177	50 - 200	12.7 x 1.9	2.3	Sq 3/8"
133236/FN/TA	PLUTO35CA/FN/TA	26.6 - 310	40 - 140	13.3 x 2.2	4.3	Sq 3/8"
133250/FN/TA	PLUTO50CA/FN/TA	44.3 - 443	20 - 90	13.8 x 2.2	4.3	Sq 1/2"

### Control units

Code	Model	Torque & Angle	Single Program	Multitorque	Serial Port	USB Port	PC Software	Weight lb	Dimensions in
032000/HPRO	EDU2AE/HPRO		•		•			5.3	7.7 x 6.7 x 4.3
032000/TOP/E	EDU2AE/TOP/E			•		•	•	5.5	7.5 x 8.1 x 4.7
031000/TOP/NT/TA	EDU2AE/TOP/NT/TA	•		•		•	•	4.4	7.5 x 8.1 x 4.7
034000/TOP/TA	EDU2AE/TOP/TA	•		•		•	•	5.5	7.5 x 8.1 x 4.7



## FAB & RAF Screwdrivers | Torque range 0.4 – 44 in-lb

FAB & RAF screwdrivers have been well-known in the electronic industry since we first developed them in the early 1990s. FAB and RAF series are Kolver's powerful, reliable and truly cost-effective tools.

### Quick to set up, easy to use

FAB and RAF tools are incredibly easy to install and operate. The torque is set externally: you'll only have to turn the clutch adjusting nut according to the required torque setting. Each screwdriver works in combination with a control unit. Its electronic control circuit cuts the power supply to the screwdriver motor in response to the clutch action as soon as the pre-set torque has been reached.

### Simple maintenance

Replacing carbon brushes and greasing the gears once a year is all you need for maintenance. EDU1FR control units for FAB and RAF screwdrivers feature a maintenance-free, state-of-the-art electronics and no wearing components. This design results in very low current to the driver's start switch and clutch switch to extend their life indefinitely.

### Safe, clean and low noise

All FAB and RAF models come standard with ESD-safe housings against electrostatic discharge. Their electric motor makes them not only energy efficient but also free of pollutants and contributes to a quieter environment (noise within 55 dB(A)). Ergonomic grip, lightweight and compact design for maximum operator comfort.

### Basic and advanced functionalities

FAB and RAF work in combination with EDU1FR series controllers, acting as an AC to DC transformer and torque controller with adjustable slow start and speed. More features available when used in combination with EDU2AE/FR controller or EDU1FR/SG with ACE screw counter (see chart on next page).

### Available Housings



INLINE – Inline versions available in lever start or push-to-start.  
Bit Drive: 1/4" hex quick change chuck

PISTOL GRIP – Trigger start, pistol grip available with top connector (PP/FR/U) or bottom connector (PP/FR).  
Bit Drive: 1/4" hex quick change chuck

ANGLE HEAD OPTION – 90° angle heads can be easily attached to inline models. Angle attachments are the ideal solution to operate where space is limited. See page 46.



ESD-safe housing



### Inline FAB Screwdrivers

Code	Model	Torque in-lb	RPM min-max	Dimensions in	Weight lb	Start Option
110003/FR	FAB03SS/FR	0.4 - 2.7	450 - 650	9.3 x 1.3	1.1	Lever Start
110010/FR	FAB10RE/FR	0.4 - 7	600 - 1000	9.3 x 1.3	1.1	Lever Start
110012/FR	FAB12RE/FR	1.8 - 10.6	600 - 1000	9.3 x 1.3	1.1	Lever Start
112012/FR	FAB12PS/FR	1.8 - 10.6	600 - 1000	9.8 x 1.3	1.1	Push-to-start
110618/FR	FAB18RE/FR	2.7 - 16	450 - 650	9.3 x 1.3	1.1	Lever Start
112618/FR	FAB18PS/FR	2.7 - 16	450 - 650	9.8 x 1.3	1.1	Push-to-start

### Inline RAF Screwdrivers

Code	Model	Torque in-lb	RPM min-max	Dimensions in	Weight lb	Start Option
120032/FR	RAF32NS/FR	6.2 - 28.3	600 - 1000	10.2 x 1.6	1.4	Lever Start
122032/FR	RAF32PS/FR	6.2 - 28.3	600 - 1000	10.6 x 1.6	1.4	Push-to-start
120638/FR	RAF38NS/FR	8 - 33.6	450 - 650	10.2 x 1.6	1.4	Lever Start
122638/FR	RAF38PS/FR	8 - 33.6	450 - 650	10.6 x 1.6	1.4	Push-to-start
120650/FR	RAF50NS/FR	8 - 44.3	400 - 700	10.2 x 1.6	1.4	Lever Start
122650/FR	RAF50PS/FR	8 - 44.3	400 - 700	10.6 x 1.6	1.4	Push-to-start

### Pistol grip FAB Screwdrivers

Code	Model	Torque in-lb	RPM min-max	Dimensions in	Weight lb	Connector Option
110013/FR	FAB12PP/FR	1.8 - 10.6	600 - 1000	8.7 x 6.3 x 1.7	1.1	Bottom connector
110013/FR/U	FAB12PP/FR/U	1.8 - 10.6	600 - 1000	8.7 x 6.4 x 1.7	1.1	Top connector
110619/FR	FAB18PP/FR	2.7 - 16	450 - 650	8.7 x 6.3 x 1.7	1.1	Bottom connector
110619/FR/U	FAB18PP/FR/U	2.7 - 16	450 - 650	8.7 x 6.4 x 1.7	1.1	Top connector

### Pistol grip RAF Screwdrivers

Code	Model	Torque in-lb	RPM min-max	Dimensions in	Weight lb	Connector Option
120033/FR	RAF32PP/FR	6.2 - 28.3	600 - 1000	8.7 x 6.3 x 1.7	1.4	Bottom connector
120033/FR/U	RAF32PP/FR/U	6.2 - 28.3	600 - 1000	8.7 x 6.4 x 1.7	1.4	Top connector
120639/FR	RAF38PP/FR	8 - 33.6	450 - 650	8.7 x 6.3 x 1.7	1.4	Bottom connector
120639/FR/U	RAF38PP/FR/U	8 - 33.6	450 - 650	8.7 x 6.4 x 1.7	1.4	Top connector
120651/FR	RAF50PP/FR	8 - 44.3	400 - 700	8.7 x 6.3 x 1.7	1.5	Bottom connector
120651/FR/U	RAF50PP/FR/U	8 - 44.3	400 - 700	8.7 x 6.4 x 1.7	1.5	Top connector

### Control units for FAB & RAF Screwdrivers

Code	Model	Adjustable Speed	Ramp Option	I/O Signals	Serial Print	Screw Count	Run Time	Weight lb	Dimensions in
010010/FR	EDU1FR	•	•	-	-	-	-	1.3	5.4 x 4.6 x 2.6
010010/FR/SG	EDU1FR/SG	•	•	•	with ACE	with ACE	-	1.3	5.4 x 4.6 x 2.6
032000/FR	EDU2AE/FR	•	•	•	•	•	•	5.3	7.7 x 6.7 x 4.3

2D and 3D drawings available on [kolver.com](http://kolver.com)

**IMPORTANT: Continuous use over 80% of torque range is not recommended.**



### KBL Brushless Screwdrivers | Torque range 0.4 – 26.7 in-lb

The perfect solution for clean room applications. KBL screwdrivers feature state-of-the-art brushless motors and clutch torque control.

**Simple set up**  
KBL tools are very easy to install and operate. The torque is set externally: you'll only have to manually adjust the front clutch according to the required torque setting.  
Each screwdriver works in combination with a control unit. Its electronic control circuit cuts the power supply to the screwdriver motor in response to the clutch action, as soon as the pre-set torque has been reached.

**Maintenance-free**  
No wearing components and no brush replacement – KBL Screwdrivers combine Swiss brushless motors with magnetic clutch switches for a real maintenance-free solution. The absence of maintenance operations guarantees high productive continuity.  
EDU1BL control units for KBL screwdrivers feature state-of-the-art electronics working at only 30 VDC. This design results in very low current to the driver's start and clutch switches to extend their life even further.

**For a cleaner environment**  
No brushes means zero emissions of carbon dust or other pollutants into the working environment, which makes KBL screwdrivers perfect for clean-room applications.

**Safe and ergonomic**  
KBL hand-held screwdrivers are available in inline and pistol type and they all come standard with ESD-safe housing.  
Small and lightweight for utmost operator comfort and with advanced ergonomic design, they ensure very low noise level, minimum vibrations and maximum safety.

**Improve your productivity by cutting investments**  
It is possible to use two screwdrivers with just one control unit by connecting a double output device called DOCK 02 (for KBL FR) or DOCK 02/S (for KBL FR/S).  
The two screwdrivers can be used at the same time for maximum productivity. 230V only.

#### Available Housings



INLINE – Inline versions available in lever start with signals (KBL FR/S) or without (KBL FR). Also available with autoreverse feature (KBL FR/AR), best used with RIV HD riveting heads. Bit Drive: 1/4" hex quick change chuck.



PISTOL GRIP – Trigger start, pistol grip available with signals (KBL P/S) or without (KBL P/FR). Bit Drive: 1/4" hex quick change chuck.



ANGLE HEAD OPTION – 90° angle heads can be easily attached to inline models. Angle attachments are the ideal solution to operate where space is limited.



ESD-safe housing



#### Inline KBL Screwdrivers

Code	Model	Torque in-lb	RPM min-max	Dimensions in	Weight lb	Control unit
Standard models						
190004	KBL04FR	0.4 - 3.5	700 - 1150	10 x 1.5	1.1	EDU1BL
190015	KBL15FR	3.5 - 13.3	700 - 1150	10 x 1.5	1.1	EDU1BL
190030	KBL30FR	6.2 - 26.5	700 - 1150	10.6 x 1.7	1.4	EDU1BL
190040	KBL40FR	8 - 35	400 - 700	10.6 x 1.7	1.4	EDU1BL
Models with I/O signals						
190004/S	KBL04FR/S	0.4 - 3.5	700 - 1150	10 x 1.5	1.1	EDU1BL/SG
190015/S	KBL15FR/S	3.5 - 13.3	700 - 1150	10 x 1.5	1.1	EDU1BL/SG
190030/S	KBL30FR/S	6.2 - 22	700 - 1150	10.6 x 1.7	1.4	EDU1BL/SG
190040/S	KBL40FR/S	8 - 26.7	400 - 700	10.6 x 1.7	1.4	EDU1BL/SG

Inline KBL Screwdrivers are also available in KBL FR/AR, with autoreverse feature.

#### Pistol grip KBL Screwdrivers

Code	Model	Torque in-lb	RPM min-max	Dimensions in	Weight lb	Control unit
Standard models						
190005	KBL04P/FR	0.4 - 3.5	700 - 1150	6 x 8.3 x 1.8	1.1	EDU1BL
190016	KBL15P/FR	3.5 - 13.3	700 - 1150	6 x 8.3 x 1.8	1.1	EDU1BL
190031	KBL30P/FR	6.2 - 26.5	700 - 1150	6 x 8.5 x 1.8	1.4	EDU1BL/HT
190041	KBL40P/FR	8 - 35	400 - 700	6 x 8.5 x 1.8	1.4	EDU1BL/HT
Models with I/O signals						
190005/S	KBL04P/S	0.4 - 3.5	700 - 1150	6 x 8.3 x 1.8	1.1	EDU1BL/SG
190016/S	KBL15P/S	3.5 - 13.3	700 - 1150	6 x 8.3 x 1.8	1.1	EDU1BL/SG
190031/S	KBL30P/S	6.2 - 22	700 - 1150	6 x 8.5 x 1.8	1.4	EDU1BL/SG
190041/S	KBL40P/S	8 - 26.7	400 - 700	6 x 8.5 x 1.8	1.4	EDU1BL/SG

#### Angle head KBL Screwdrivers

Code	Model	Torque in-lb	RPM min-max	Dimensions in	Weight lb	Control unit
190004/A	KBL04FR/ANG	0.4 - 3.5	700 - 1150	12.4 x 1.5	1.3	EDU1BL
190015/A	KBL15FR/ANG	3.5 - 13.3	700 - 1150	12.4 x 1.5	1.3	EDU1BL
190030/AD	KBL30FR/ANG	6.2 - 26.5	700 - 1150	13 x 1.7	1.5	EDU1BL/HT
190040/AD	KBL40FR/ANG	8 - 35	400 - 700	13 x 1.7	1.5	EDU1BL/HT

#### Control units for KBL Screwdrivers

Code	Model	Settable Speed	Ramp Option	I/O Signals	Serial Print	Screw Count	Min-Max Run Time	Weight lb	Dimensions in
003000	EDU1BL	•	-	-	-	-	-	1.3	5.4 x 4.6 x 2.6
003000/SG	EDU1BL/SG	•	•	•	with ACE	with ACE	with ACE	1.3	5.4 x 4.6 x 2.6

2D and 3D drawings available on kolver.com

IMPORTANT: Continuous use over 80% of torque range is not recommended.



## KBL Screwdrivers for Automation | Torque range 0.4 – 26.7 in-lb

KBL CA Screwdrivers combine state-of-the-art brushless motors with an aluminium housing for quick and easy installation on robots and automatic machines.

### Designed for automation

KBL CA tools are supplied in an aluminium body for a quick and easy integration with automatic machines and screw feeding systems. KBL tools in CA/FN version are equipped with a flange mount and reciprocating spindle for high-intensity applications.

### Easy to install and operate

Each KBL CA screwdriver works in combination with an EDU1BL/SG control unit. Its electronic control circuit cuts the power supply to the screwdriver motor in response to the clutch action, as soon as the pre-set torque has been reached.

KBL's torque clutch only needs to be set once and guarantees accurate repeatability on any kind of joint.

### Industry 4.0 with KBL

Transitioning to Industry 4.0 is easy with KBL CA screwdrivers. They can be easily connected to robots or automatic machines through their EDU 1BL/SG controller's proper connectors to manage input/output signals such as start, stop, error and more.

### No maintenance required

Automation requires tools capable of keeping high quality standards, even on heavy-duty applications. KBL Screwdrivers combine Swiss brushless motors with magnetic clutch switches for a real maintenance-free solution. The absence of maintenance operations guarantees high productive continuity.

### For clean-room environments

KBL screwdrivers are perfect for automated applications requiring clean-room standards. No brushes means zero emissions of carbon dust or other pollutants into the working environment, which guarantees high-quality assembly on any joint.

### Available Housings



ALUMINIUM BODY (KBL CA) – Specifically designed for automation. Easy to install on any machine or robot. Also available with autoreverse feature (KBL FR/AR), best used with RIV HD riveting heads.



ALUMINIUM BODY WITH FLANGE MOUNT (KBL CA/FN) – Ideal for automated high volume/high duty applications. Flange and telescopic spindle available together or separately.



Robotic application  
**SCAN TO WATCH**



ESD-safe housing



### Aluminium housing KBL Screwdrivers

Code	Model	Torque in-lb	RPM min-max	Dimensions in	Weight lb	Bit Drive
190004/CA	KBL04FR/CA	0.4 - 3.5	700 - 1150	10.1 x 1.6	1.3	Hex 1/4"
190015/CA	KBL15FR/CA	3.5 - 13.3	700 - 1150	10.1 x 1.6	1.3	Hex 1/4"
190030/CA	KBL30FR/CA	6.2 - 26.5	700 - 1150	10.4 x 1.6	1.5	Hex 1/4"
190040/CA	KBL40FR/CA	8 - 35	400 - 700	10.4 x 1.6	1.5	Hex 1/4"

### Aluminium housing KBL Screwdrivers with flange mount

Code	Model	Torque in-lb	RPM min-max	Dimensions in	Weight lb	Bit Drive
190004/CA/FN	KBL04FR/CA/FN	0.4 - 3.5	700 - 1150	13 x 1.6	1.4	Hex 1/4"
190015/CA/FN	KBL15FR/CA/FN	3.5 - 13.3	700 - 1150	13 x 1.6	1.4	Hex 1/4"
190030/CA/FN	KBL30FR/CA/FN	6.2 - 26.5	700 - 1150	13.3 x 1.6	1.8	Hex 1/4"
190040/CA/FN	KBL40FR/CA/FN	8 - 35	400 - 700	13.3 x 1.6	1.8	Hex 1/4"

### Control unit for KBL CA Screwdrivers

Code	Model	Settable Speed	Ramp Option	I/O Signals	Serial Print	Screw Count	Min-Max Run Time	Weight lb	Dimensions in
003000/SG	EDU1BL/SG	•	•	•	with ACE	with ACE	with ACE	1.3	5.4 x 4.6 x 2.6

2D and 3D drawings available on [kolver.com](http://kolver.com)

**IMPORTANT:** Continuous use over 80% of torque range is not recommended.



### ACC Screwdrivers | Torque range 1.8 – 39.8 lbf-in

ACC screwdrivers are direct plug-in tools with built-in PCB for automatic cut off and AC to DC rectifier. They are ideal for applications where portability is needed to minimize costly set-up time. DC voltage is 110V. ACC models have the unique feature of selectable push to start or push and lever start: to select the working mode just slide the switch located by the start lever.

All ACC models feature shut off torque control through mechanical clutch. It is possible to lock their mechanical clutch and avoid any accidental torque change by adding an optional Lock-out Cover, available for all ACC models (code 219011).



Reverse Switch



Torque Adjusting Nut Cover

#### Inline ACC Screwdrivers with Built-in Controller

Code	Model	Torque lbf-in	RPM max	L x Ø in	Weight lb	Bit Drive
141910	ACC2210	1.8 - 8.9	950	10 x 1.4	1.7	Hex 1/4"
141920	ACC2220	6.2 - 17.7	950	10 x 1.4	1.8	Hex 1/4"
151222	ACC2222	8 - 17.7	2400	10.4 x 1.5	1.9	Hex 1/4"
151930	ACC2230	8.8 - 26.6	950	10.4 x 1.5	1.9	Hex 1/4"
151945	ACC2245	8.9 - 39.8	450	10.4 x 1.5	1.9	Hex 1/4"

2D and 3D drawings available on [kolver.com](http://kolver.com)

**IMPORTANT:** Continuous use over 80% of torque range is not recommended.

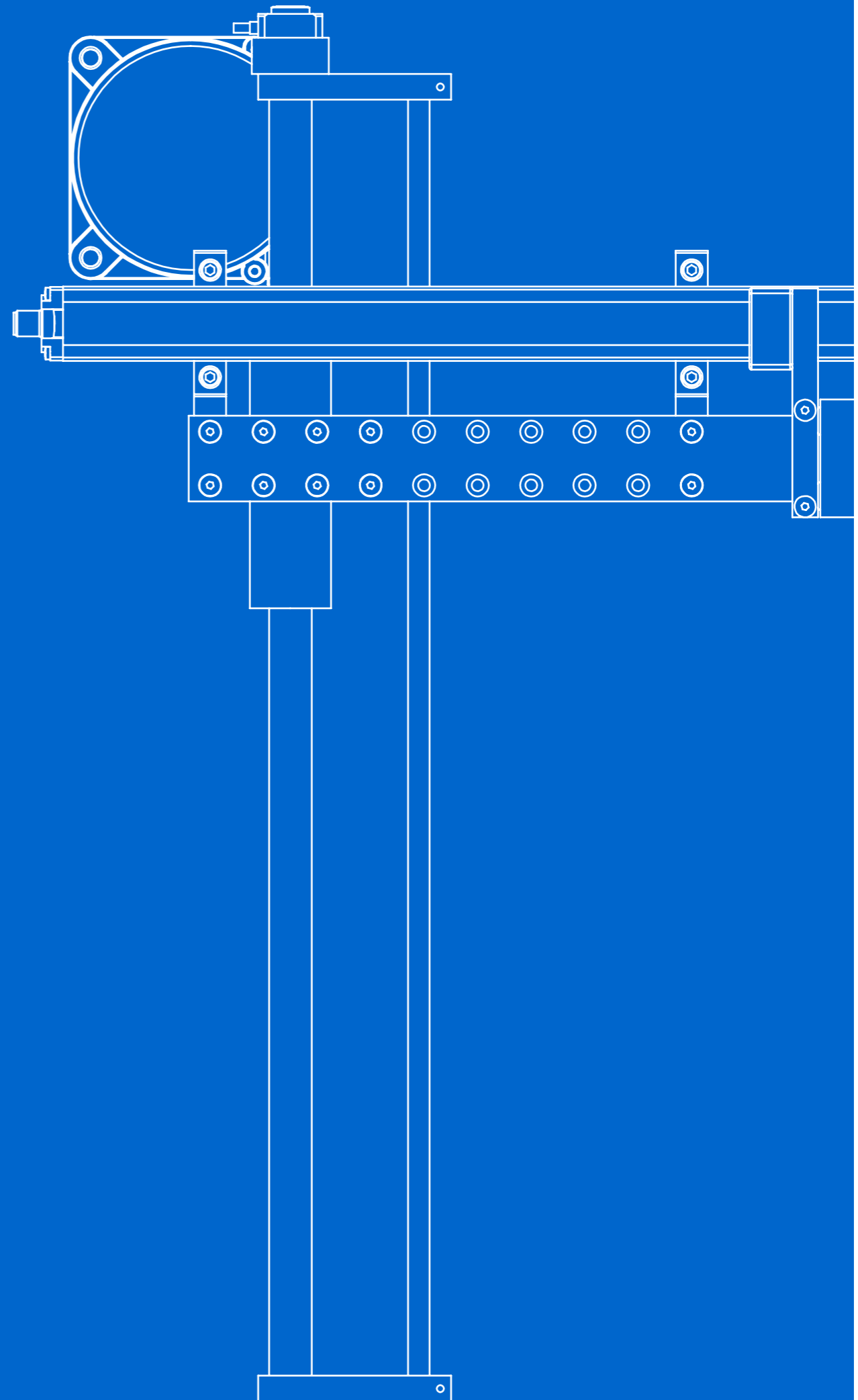

**TORQUE TESTERS / SCREW FEEDERS  
REACTION ARMS / POSITIONING SYSTEMS**





### K-TESTER and Mini K/S Torque Testers | Torque range 0.4 – 885 lbf-in

Controlling torque is vital for companies to ensure their product's quality. Fasteners that are insufficiently torqued can vibrate loose and excessive torque can strip threaded fasteners. Using a quality torque tester has become increasingly important for most companies to ensure that proper torque is being applied.

#### K-TESTER Series – Advanced Torque Testers

The K-TESTER is Kolver's cutting-edge torque analyzer. Versatile and precise, it can be used with both static and rotary transducers, depending on the application

The intuitive touchscreen torque readout provides real-time torque graph visualization, while live PC connectivity enhances testing capabilities through our K-Torque Analyser companion software.

With support for up to 64 programs and advanced reporting, the K-TESTER offers unparalleled efficiency for diverse torque testing needs.

#### Mini Ke/S Series with External Transducer

The Mini Ke/S system consists of a torque readout and an external rotary transducer. By connecting a rotary torque transducer between an electric or pneumatic tool and an assembly application, you can monitor the real torque being applied from the tool to fastener or bolt.

It is possible to connect different transducers to the same torque reader by setting the proper Correction Factor (FATC). A Mini Ke/S is the ideal torque-auditing tool for testing the actual torque being applied on the assembly application.

#### Mini K/S Series – Portable Torque Testers

MINI K/S Torque Testers feature a built-in transducer. These easy-to-use torque testers are ideal for checking all power tools up to 442 lbf-in. The small size and portability of MINI K/S make them ideal for checking torque tools on the production floor regularly to ensure the tools are always calibrated.

- Three units of torque measurement available; Nm, Kg.cm, in/lbs.
- Manual and auto reset functions to clear displayed values.
- Battery powered (9V) and AC adapter. 9V battery provides 30 hours of continuous operation.
- Automatic shut down to extend battery life.
- mini USB port for printing torque values, date and hour
- Torque Tester includes a washer-based joint simulator (miniK5/S and miniK20/S) or built in joint simulator (miniK1/S), instructions manual, certificate of calibration and a case.



#### K-TESTER Torque Testers

Code	Model	Torque range lbf-in	Readout Dimensions in	Readout Weight lb	Transducer Weight lb	Input size	Joint Simulator	Connecting Port
with Static Transducer								
021406/F1	K-TESTER-KT11	0.4 - 8.9	6.5 x 6.7 x 2.6	2.5	2.5	Hex 1/4"	240640 M4	USB, mini USB, Ethernet
021406/F5	K-TESTER-KT15	2.7 - 44.3	6.5 x 6.7 x 2.6	2.5	2.5	Hex 1/4"	240600 M6	USB, mini USB, Ethernet
021406/F20	K-TESTER-KT120	4.4 - 177	6.5 x 6.7 x 2.6	2.5	2.5	Hex 1/4"	240800 M8	USB, mini USB, Ethernet
021406/F50	K-TESTER-KT150	17.7 - 442.5	6.5 x 6.7 x 2.6	2.5	2.5	Sq 3/8"	240901 M12	USB, mini USB, Ethernet
021406/F100	K-TESTER-KT1100	44.3 - 885.1	6.5 x 6.7 x 2.6	2.5	2.5	Sq 1/2"	240902 M12	USB, mini USB, Ethernet
with Rotary Transducer								
021406/R5	K-TESTER-KTE11	4.4 - 44.3	6.5 x 6.7 x 2.6	2.5	0.9	-	-	USB, mini USB, Ethernet
021406/R25	K-TESTER-KTE125	17.7 - 221.3	6.5 x 6.7 x 2.6	2.5	1.9	-	-	USB, mini USB, Ethernet
021406/R50	K-TESTER-KTE150	44.3 - 442.5	6.5 x 6.7 x 2.6	2.5	2.7	-	-	USB, mini USB, Ethernet
021406/R100	K-TESTER-KTE1100	88.5 - 885.1	6.5 x 6.7 x 2.6	2.5	3.1	-	-	USB, mini USB, Ethernet

#### Mini K/S Torque Testers

Code	Model	Torque range lbf-in	Dimensions in	Weight lb	Joint Simulator	External Transducer	Connecting Port
021402/S	Mini K1/S	0.9 - 8.9	5.9 x 2.8 x 1.8	1.8	Internal Simulator	-	mini USB
021403/S	Mini K5/S	2.7 - 44.3	5.9 x 2.8 x 1.8	1.8	Semi-Elastic M6	-	mini USB
021404/S	Mini K20/S	4.4 - 177	5.9 x 2.8 x 1.8	1.8	Semi-Elastic M8	-	mini USB
021405/S/S	Mini Ke5/S	4.4 - 44.3	5.9 x 2.8 x 1.8	1.1	-	KTE5 (included)	mini USB
021405/S/S	Mini Ke25/S	17.7 - 221.3	5.9 x 2.8 x 1.8	1.1	-	KTE25 (included)	mini USB
021405/S/S	Mini Ke50/S	44 - 442	5.9 x 2.8 x 1.8	1.1	-	KTE50 (included)	mini USB

#### K-TorqueAnalyser Software

K-Torque Analyser is the new companion software for managing the K-TESTER and visualizing graphs & reports from a tablet/PC connected via ethernet.

Functionality includes:

- real-time displaying and archiving of data from the K-TESTER;
- analysis and comparison of tightening operations and torque data;
- advanced reporting;
- managing of device settings and programs;

#### Torque Analyser Software

The new Kolver® Torque Analyser software for Mini K/S and Mini Ke/S Torque Testers features real-time tracking of each measurement and calculation of CM and CMK.

A Real-time chart for each torque measurement is displayed on your PC screen (when "track mode" on the tester is enabled). The chart will show the trend of the single screwing operation or, in case of multiple screwing operations it will show the results according to the settings on the torque tester and software (for example if you're keeping track of multiple operations at max torque, the chart will show the trend of these max torques). You can also export an Excel file (max 30 measurements) with corresponding CM-CMK values: this is useful for testing the torque accuracy of the screwdriver.

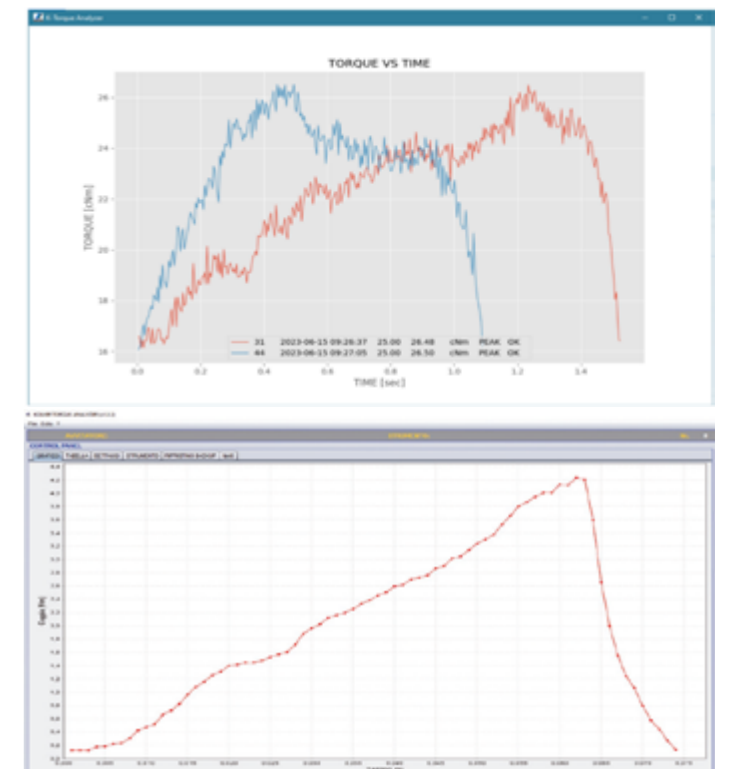



## Torque Reaction Arms | Up to 664 lbf-in

Support arms manoeuvre smoothly as they absorb the torque reactions from the screwdrivers providing ergonomic support for the operator. They reduce RMI (Repetitive Motion Injury) and CTS (Carpal Tunnel Syndrome) while boosting production.

### Folding and Linear Torque Reaction Arm Series

Torque folding arms have been designed to eliminate the reaction generated by screwdrivers when they stop at the pre-set torque. Options include table or wall mount.

Linear arms keep the tool perpendicular and prevent cross threading and side load. Each model extends in horizontal direction and arm length is adjustable. The fluid movement increases precision and production for a variety of torque applications.

### Telescopic Carbon Arm Series

CAR series torque reaction arms eliminate the reaction that screwdrivers generate when they stop at the pre-set torque (up to 442 lbf-in). Their carbon structure makes them extremely lightweight and incredibly resistant at the same time. This means that they resist degradation in high fatigue applications much better than conventional materials.

### Suspended Torque Arm Series

SAR Suspended Torque Arms are the ideal solution to increase productivity. They can be easily installed on most workplaces to help the operator handle the screwdriver in total safety and stability while keeping the workspace clear. With minimized reaction force you will also improve finished product quality because there is no movement of the tool and all torque is absorbed in the joint.

Three models available, depending on the motion of the axes. SAR arms are supplied without tool holder – to be purchased depending on the screwdriver used (see chart on the next page).

### Support arm models



### Folding and Linear Torque Reaction Arms

Code	Model	Arm Weight lb	Max Payload lb	Min Reach in	Max Reach in	Max Torque in-lb
010600	PA2KOL	5.5	3.3	17.3	25.2	177
010602	PA7KOL	9.3	22*	19.6	37.4	664
010603	PS7KOL	11.7	22*	11.8	39.4	664
010681	LINAR1	3.3	3.3	7.2	26.2	221
010682	LINAR2	3.3	3.3	7.2	26.2	442
010683	LINART	3.5	3.1	4.5	29.1	221

\* Required payload is to be specified with order

### Folding and Linear Torque Reaction Arms with Autoadvance Kit

Code	Model	Arm Weight lb	Piston Stroke in	Min Reach in	Max Reach in	Max Torque in-lb
010682/A	LINAR2/A	13.4	0 - 2	7.2	26.2	442

Autoadvance kit  
020099 The Autoadvance kit can be supplied separately – to be installed on LINAR2 and LINART to convert them into /A models.

### Telescopic Torque Reaction Arms

Code	Model	Arm Weight lb	Max Payload lb	Min Reach in	Max Reach in	Max Torque in-lb
010661	CAR101	0.4	5.9	21.6	35.7	89
010663	CAR281	1.3	5.9	19.3	37.4	221
010664	CAR282	1.5	5.9	28.7	65	221
010665	CAR501	1.4	5.9	19.3	37.4	442
010666	CAR502	1.8	5.9	28.7	65	442

### Suspended Torque Arms

Code	Model	Arm weight lb	Max Payload lb	Vertical Z Stroke mm	Horizontal X Stroke mm	Lateral Y Stroke mm	Max Torque in-lb
010690/Z/5	SAR15 Z	2.6	3.4	14.3	-	-	133
010690/XZ/85	SAR15 XZ 85	2.6	3.4	14.3	27.2	-	133
010690/XYZ/855	SAR15 XYZ 855	3.7	2.9	34.8	27.2	14.8	133

Tool holders for SAR arms

010695	Tool holder for PLUTO and RAF series inline screwdrivers
010698	Tool holder for FAB, NATO & MITO series inline screwdrivers
010695/P	Tool holder for right angle PLUTO screwdrivers (up to 133 lbf-in)
010695/UNI	Universal Tool Holder for any screwdriver (max diameter 1.85 in)

**IMPORTANT: A diameter reduction adapter (code 234545) is required when LINAR and CAR arms are used with PLUTO35 or PLUTO50 screwdrivers (Ø 57 mm).**

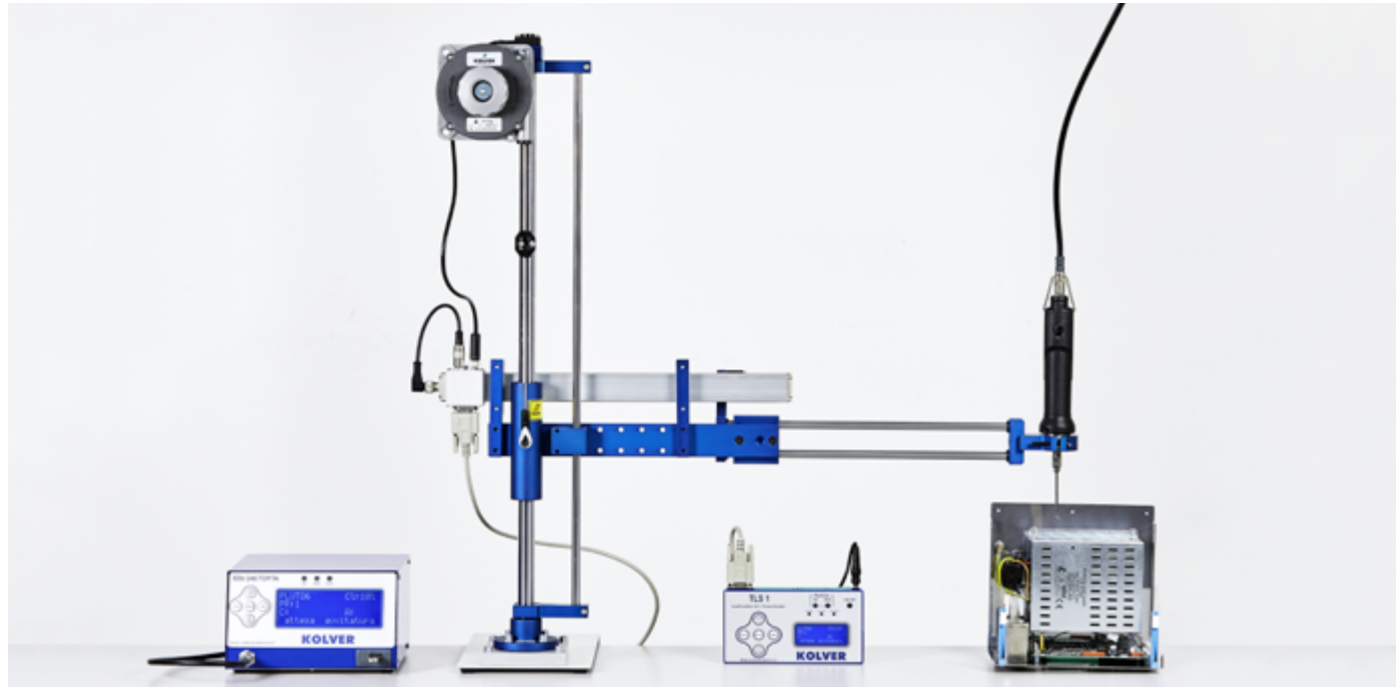

## Positioning Arms | Up to 442 lbf-in

TLS1 is an intelligent system that error-proofs your assembly ensuring that every screw is in the correct location at the right torque. Assembly sequences and X-Y coordinates are easily programmed with user interface screens through the keypad from the intuitive menu. Torque programs are automatically selected and enabled from the screwdriver controller based on the TLS1 Arm locations and current sequence step. No PC is required.

### Main features

- 8 available programs and up to 35 screws per program.
- Screw position (length/angle) with accuracy: length  $\pm 1$  mm; angle  $\pm 1^\circ$ .
- Programmable tolerance and manual reset.
- Password protected.
- External keyboard and serial port for easy programming and statistics.

### TLS1 with CAR Arm

The TLS1/CAR Arm consists of a torque reaction arm with an encoder mounted at the pivot point and with a linear metering resistor. The encoder records the angle and the linear resistor records the distance. X-Y accuracy can be set by the operator according to each application.

### TLS1 with Linear Arm

TLS1/LINAR1 and TLS1/LINAR2 positioning arms work just like LINAR1 and LINAR2 with the addition of positioning sensors for a real time feedback on the position of the arm. Max torque and reach are the same as LINAR1 and LINAR2 respectively (see page 41). Adapter code 234545 is required for screwdriver model PLUTO35 and PLUTO50.

### TLS1 with Folding Arm

TLS1/LINART features a folding arm for extreme flexibility and accuracy. Thanks to the positioning sensors you can have a real time feedback on the position of the arm, which is very useful for default calibrations. Max torque and reach are the same as LINART (see page 41).

### TLS1 with Suspended Arm

A SAR XYZ/TLS1 is ideal for assembly stations where space is limited. It can be easily installed on most workplaces to help the operator handle the screwdriver in total safety and stability. The TLS1 System makes each operation truly error-proof: it tracks the X-Y-Z coordinates to make sure that each screw is tightened only when the screwdriver is in correct position. Max torque and reach are the same as SAR XYZ (see page 41).

### Positioning arm models

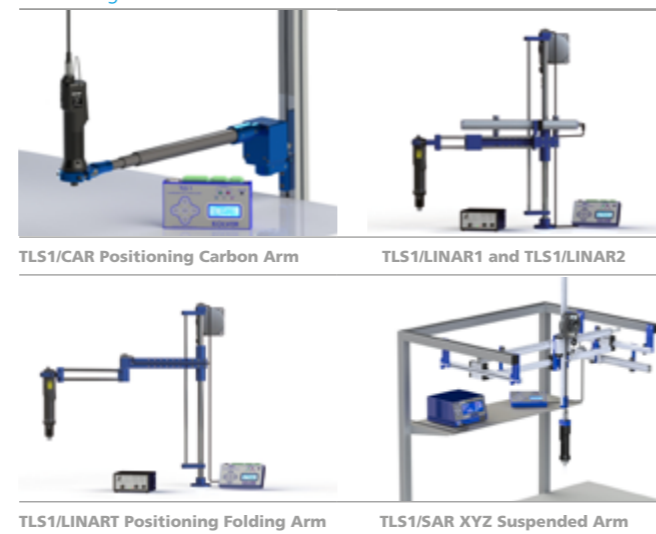

TLS1/CAR Positioning Carbon Arm

TLS1/LINAR1 and TLS1/LINAR2

TLS1/LINART Positioning Folding Arm

TLS1/SAR XYZ Suspended Arm



### Folding and Linear Positioning Arms

Code	Model	Max Torque lbf-in	Min Reach in	Max Reach in	Min distance between screws at max extension
010681/TLS1	LINAR1/TLS1	221	7.2	26.2	0.24 in
010682/TLS1	LINAR2/TLS1	442	7.2	26.2	0.24 in
010683/TLS1	LINART/TLS1	221	4.5	29.1	0.28 in

### Folding and Linear Positioning Arms with Autoadvance Kit

Code	Model	Arm Weight lb	Piston Stroke in	Min Reach in	Max Reach in	Min distance between screws (max extension)
010682/TLS1/A	LINAR2/TLS1/A	13.4	0 - 2	7.2	26.2	0.24 in

### Autoadvance kit

020099 The Autoadvance kit can be supplied separately – to be installed on LINAR2/TLS1 and LINART/TLS1 to convert them into /A models.

### Telescopic Positioning Arms

Code	Model	Max Torque lbf-in	Min Reach in	Max Reach in	Min distance between screws at max extension
010663/TLS1	CAR281/TLS1	221	19.3	37.4	0.35 in
010664/TLS1	CAR282/TLS1	221	28.7	65	0.59 in
010665/TLS1	CAR501/TLS1	442	19.3	37.4	0.35 in
010666/TLS1	CAR502/TLS1	442	28.7	65	0.59 in

### Suspended Positioning Arms

Code	Model	Max Torque lbf-in	Arm Weight lb	Vertical Stroke Z in	Vertical Stroke X in	Vertical Stroke Y in
010690/XYZ/TLS1	SAR15 XYZ/TLS1	133	17.6	34.8	27.2	14.8

### Tool holders for SAR arm

010695	Tool holder for PLUTO and RAF series inline screwdrivers
010698	Tool holder for FAB, NATO & MITO series inline screwdrivers
010695/P	Tool holder for right angle PLUTO screwdrivers (up to 133 lbf-in)
010695/UNI	Universal Tool Holder for any screwdriver (max diameter 1.9 in)

For all of our arms, one of the following cables must be specified at time of purchase:

260003/1	Cable to connect TLS system to EDU1FR/SG controller
260004/1	Cable to connect TLS system to EDU1BL/SG, EDU2AE, EDU2AE/HPro, EDU2AE/TOP or EDU2AE/TOP/TA controller
260004/KDU	Cable to connect TLS system to KDU controller

**IMPORTANT: A diameter reduction adapter (code 234545) is required when LINAR and CAR arms are used with PLUTO35 or PLUTO50 screwdrivers ( $\varnothing$  2.24 in).**

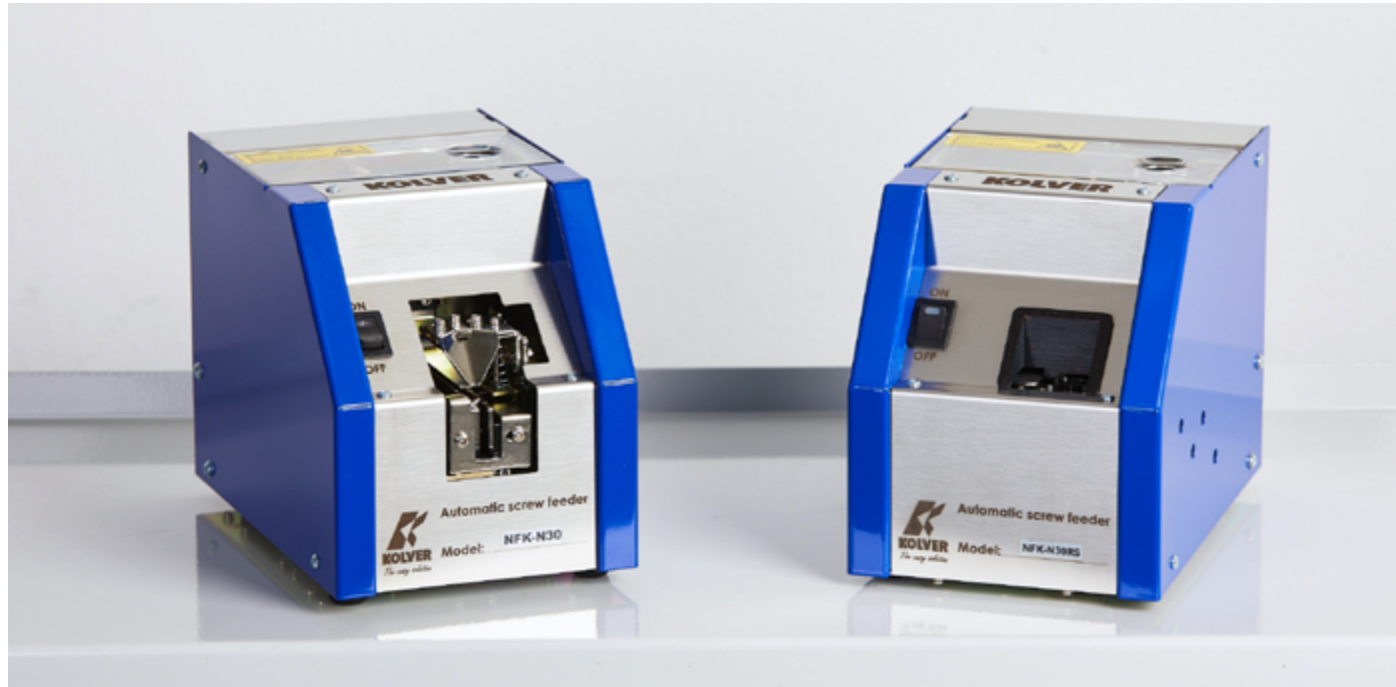

## NFK Screw Feeders | Up to M5 Screws

When it comes to speeding up assembly operations, NFK screw feeders are a game changer. These simple and small devices are meant to avoid any time loss between one tightened screw and the next. Screw feeders present one screw at a time with no need for the operator to manually pick up each screw. Models for automated applications are also available.

### Fully adjustable

NFK-N screw feeders are supplied with interchangeable spacers between the rails (spacer size: 0.05 to 0.20 in). You can also combine spacers to reach the desired rail width. Model NFK UNI can be used with any (non-countersunk) screw with diameter 0.06 – 0.20 in.

### Speed up automated applications

NFK RS delivers one screw at a time to a specific position so that one single screw can be easily picked up when using an autocatcher or suction head (see section Accessories for further information). A trimmer on the side panel allows to adjust how fast each screw is supplied. Available for screws with shank diameter from 0.05 in up to 0.20 in. An optional cover is available in order to avoid screws falling inside the NFK RS screw feeder.

The whole NFK Screw Feeder series can handle up to 0.79-in-long screws.

### NFK Series Screw Suppliers for Manual Use

Code	Model	Max Shank Diameter in
014705	NFK UNI	Any size between 0.06 - 0.2
014514	NFK N14	0.06
014517	NFK N17	0.07
014520	NFK N20	0.08
014523	NFK N23	0.09
014526	NFK N26	0.10
014530	NFK N30	0.12
014530	NFK N35	0.14
014540	NFK N40	0.16
014550	NFK N50	0.20

### NFK Series Screw Suppliers for Automation

Code	Model	Max Shank Diameter in
014512/RS	NFK N12/RS	0.05
014517/RS	NFK N17/RS	0.07
014520/RS	NFK N20/RS	0.08
014523/RS	NFK N23/RS	0.09
014526/RS	NFK N26/RS	0.10
014530/RS	NFK N30/RS	0.12
014535/RS	NFK N35/RS	0.14
014540/RS	NFK N40/RS	0.16
014550/RS	NFK N50/RS	0.20
014560/RS	NFK N60/RS	0.24

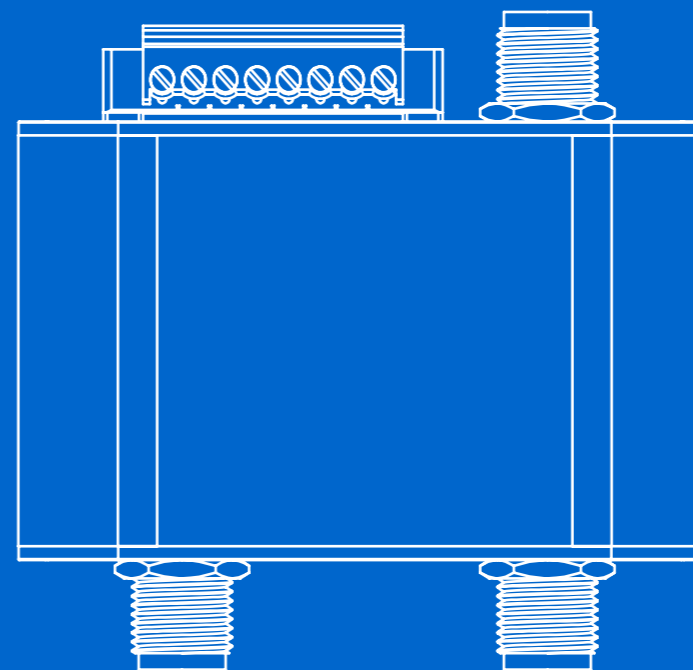
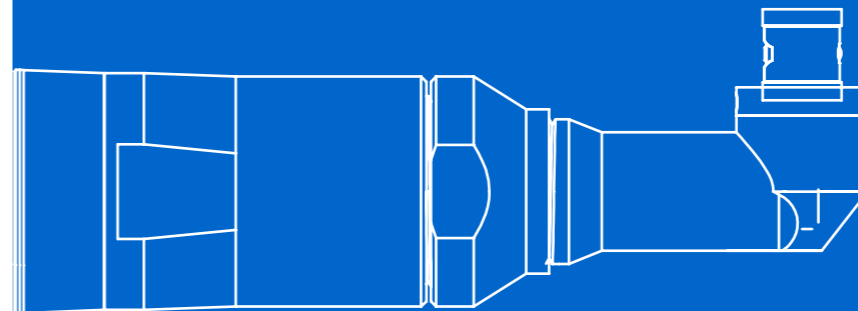
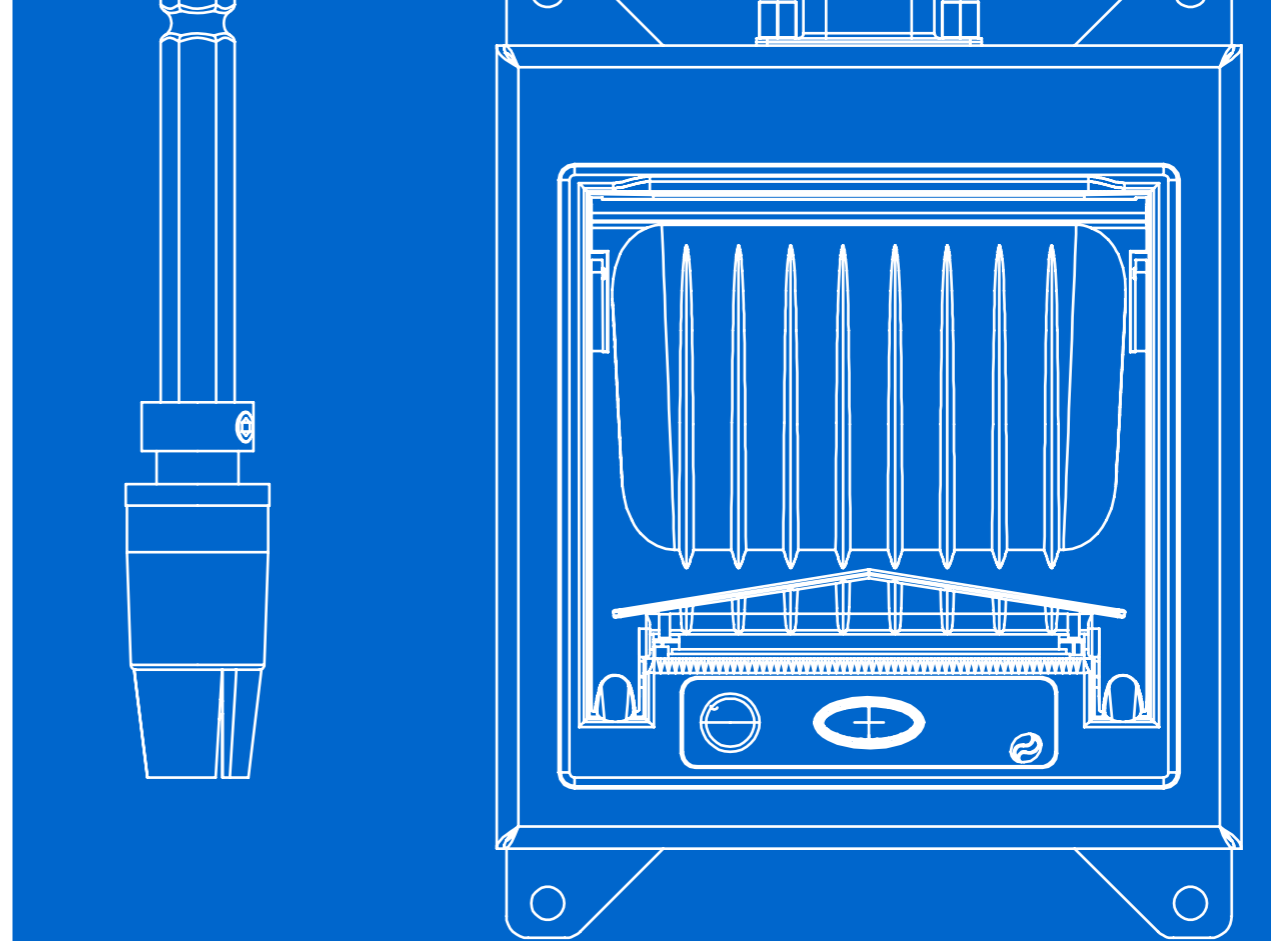



Accessories for FAB & RAF Screwdrivers

Code	Model	Description
<b>90° Angle attachments</b>		
010100	ANG HD1	90° Angle head for FAB Series, 1/4" hex output
010120	ANG HD2	90° Angle head for RAF Series, 1/4" hex output
010143	ANG HD8	Heavy duty 90° angle head for FAB Series, 1/4" hex output
010144	ANG HD9	Heavy duty 90° angle head for RAF Series, 1/4" hex output
<b>Lock-out cover</b>		
219012	Lock-out cover	Lock-out cover with adjustment key for FAB. A lock-out cover locks the screwdriver's clutch in order to avoid any accidental torque change.
<b>Tool holders</b>		
010300	TECBA1	TECBA1 tool balancers allow screwdrivers to be positioned over the workstation for maximum operator comfort. 0.9-2.2 lb capacity.
010175	Pistol FAB & RAF wall support	Wall supports for pistol screwdrivers can be fixed to a vertical surface to easily store FAB and RAF pistol tools when not in use.
010176	Wall support for angle RAF	Wall supports can be fixed to a vertical surface to easily store RAF tools with angle head when not in use.
<b>Cables (to connect FAB &amp; RAF screwdrivers to EDU1FR controllers)</b>		
200063	98 in	Standard 5 pin cable for FAB & RAF – included with screwdriver
200063/H	98 in	5 pin cable with strain relief – for heavy duty applications
200563	197 in	5 pin cable, 197 in length
200563/S	197 in	5 pin spiral cable
200863	315 in	5 pin cable, 315 in length



Accessories for KBL Hand-held Screwdrivers

Code	Model	Description
<b>Clutch cover</b>		
020028	Clutch cover	Model for KBL04FR and KBL15FR. It prevents the operator from accidentally altering the clutch adjustment.
020029	Clutch cover	Model for KBL30FR and KBL40FR. It prevents the operator from accidentally altering the clutch adjustment.
<b>Riveting heads</b>		
010181	RIV HD2	0.31 in hole. Model for KBL30FR and KBL04FR screwdrivers, also for models with signals (KBL FR/S) and autoreverse (KBL FR/AR).
010183	RIV HD4	0.11 in hole. Model for KBL04FR and KBL15FR screwdrivers, also for models with signals (KBL FR/S) and autoreverse (KBL FR/AR).
010184	RIV HD5	0.11 in hole. Model for KBL30FR and KBL04FR screwdrivers, also for models with signals (KBL FR/S) and autoreverse (KBL FR/AR).
<b>Tool holders</b>		
010500	ARM PV1	ARM PV1 support arm consists of a vertical support on which a 180° pivoting arm is attached.
010300	TECBA1	TECBA1 tool balancers allow screwdrivers to be positioned over the workstation for maximum operator comfort. 0.4-1 kg capacity.
010175	Wall support for KBL	Wall supports can be fixed to a vertical surface to easily store KBL tools when not in use.

Accessories for KBL CA Automated Screwdrivers

Code	Model	Description
<b>Flange mount kits</b>		
800406	1/4" - 1/4" kit for 04-15	1/4" - 1/4" flange mount kit that turns KBL04 CA and KBL15 CA screwdrivers into KBL CA/FN.
800407	1/4" - 1/4" kit for 30-40	1/4" - 1/4" flange mount kit that turns KBL30 CA and KBL40 CA screwdrivers into KBL CA/FN.
<b>Telescopic spindle</b>		
800322	1/4" - 1/4"	Model for KBL /FN. Max 62 lbf-in.
<b>Clutch cover</b>		
020028/CA	Clutch cover	Model for KBL04FR/CA and KBL15FR/CA. It prevents the operator from accidentally altering the clutch adjustment.
020029/CA	Clutch cover	Model for KBL30FR/CA and KBL40FR/CA. It prevents the operator from accidentally altering the clutch adjustment.
<b>Vacuum attachments</b>		
010111/1	A2	For non-magnetic M2-M2.6 screws. It can be installed on any screwdriver.
010111/2	A3	For non-magnetic M3-M4 screws. It can be installed on any screwdriver.
010122	ASP HD10	Rubber pad output. Best suited for round-headed screws. Model specifically designed for KBL04 and KBL15.
010122/UNI	ASP HD10/UNI	Metal tube output. Best suited for grub, allen and long screws. Model specifically designed for KBL04 and KBL15.
010123	ASP HD11	Rubber pad output. Best suited for round-headed screws. Model specifically designed for KBL30 and KBL40.
010123/UNI	ASP HD11/UNI	Metal tube output. Best suited for grub, allen and long screws. Model specifically designed for KBL30 and KBL40.
<b>Autocatchers</b>		
010113	AC 2.3	For M2-M3 screws. Easily picks up non-magnetic screws with a small plastic clamp.
010114	AC 3.5	For M3-M5 screws. Easily picks up non-magnetic screws with a small plastic clamp.

Cables (to connect KBL screwdrivers to EDU1BL controller)

200063	98 in	Standard 5 pin cable for KBL series – included with screwdriver
250063/N	98 in	Standard 8 pin cable for KBL /S (with signals) series – included with screwdriver
200063/H	98 in	5 pin cable with strain relief for KBL series – heavy duty applications
250063/H	98 in	8 pin cable with strain relief for KBL /S (with signals) series – heavy duty applications
200563	197 in	5 pin cable, 197 in length for KBL series
250563	197 in	8 pin cable, 197 in length for KBL /S (with signals) series
200563/S	197 in	5 pin spiral cable for KBL series
250563/S	197 in	8 pin spiral cable for KBL /S (with signals) series



Accessories for PLUTO Hand-held Screwdrivers

Code	Model	Description
<b>Riveting heads</b>		
010180	RIV HD1	0.31 in hole. Model for PLUTO3D, PLUTO6D, PLUTO10D/N, PLUTO15D/N.
010182	RIV HD3	0.11 in hole. The 0.11 in hole can be modified up to 0.4 in. Model for PLUTO3D, PLUTO6D, PLUTO10D/N, PLUTO15D/N.
<b>Vacuum attachments</b>		
010111/1	A2	For non-magnetic M2-M2.6 screws. It can be installed on any screwdriver.
010111/2	A3	For non-magnetic M3-M4 screws. It can be installed on any screwdriver.
010121	ASP HD9	Rubber pad output. Best suited for round-headed screws. Model specifically designed for PLUTO3, PLUTO6, PLUTO10 and PLUTO15.
010121/UNI	ASP HD9/UNI	Metal tube output. Best suited for grub, allen and long screws. Model specifically designed for PLUTO3, PLUTO6, PLUTO10 and PLUTO15.
<b>Autocatchers</b>		
010113	AC 2.3	For M2-M3 screws. Easily picks up non-magnetic screws with a small plastic clamp.
010114	AC 3.5	For M3-M5 screws. Easily picks up non-magnetic screws with a small plastic clamp.
<b>Tool holders and adaptors</b>		
234545	Diametre adaptor	Reduction adaptor for PLUTO35 & 50CA drivers allowing interface with LINAR and CAR series arms
010300	TECBA1	TECBA1 tool balancers allow screwdrivers to be positioned over the workstation for maximum operator comfort. 0.9-2.2 lb capacity.
010312	TECBA2	TECBA2 tool balancers allow screwdrivers to be positioned over the workstation for maximum operator comfort. 2.2-4.4 lb capacity.
010313	TECBA3	TECBA3 tool balancers allow screwdrivers to be positioned over the workstation for maximum operator comfort. 4.4-6.6 lb capacity.
010175	Wall support for pistol PLUTO	Wall supports can be fixed to a vertical surface to easily store PLUTO pistol tools when not in use.
010176	Wall support for angle PLUTO	Wall supports can be fixed to a vertical surface to easily store PLUTO tools with angle head when not in use.
<b>Cables (to connect screwdriver to controller)</b>		
200063	98 in	Standard 5 pin cable for PLUTO series – included with screwdriver
250063/N	98 in	Standard 8 pin cable for PLUTO /TA (Torque & Angle) series – included with screwdriver
200063/H	98 in	5 pin cable with strain relief for PLUTO series – heavy duty applications
250063/H	98 in	8 pin cable with strain relief for PLUTO /TA (Torque & Angle) series – heavy duty applications
200563	197 in	5 pin cable, 197 in length for PLUTO series
250563	197 in	8 pin cable, 197 in length for PLUTO /TA (Torque & Angle) series
200563/S	197 in	5 pin spiral cable for PLUTO series
250563/S	197 in	8 pin spiral cable for PLUTO /TA (Torque & Angle) series



Accessories for PLUTO CA Automated Screwdrivers

Code	Model	Description
<b>Flange mount kits</b>		
800400	1/4" - 3/8" kit	An 1/4" - 3/8" flange mount kit turns a PLUTO (3, 6, 10 or 15) CA into PLUTO CA/FN2.
800401	3/8" - 3/8" kit	For PLUTO20. It turns a PLUTO20CA into PLUTO20CA/FN.
800403	3/8" - 3/8" kit	For PLUTO35. It turns a PLUTO35CA into PLUTO35CA/FN.
800404	1/4" - 1/4" kit	An 1/4" - 1/4" flange mount kit turns a PLUTO FR/CA clutch screwdriver into PLUTO FR/CA/FN.
<b>UR (Universal Robots®) adaptor</b>		
010695/UR	UR-Mount	Tool holder for PLUTO3, 6, 10 & 15CA and CA/FN2 series drivers. To be attached to Universal Robots® robotic arm.
<b>Telescopic spindles</b>		
800319	1/2" - 1/2"	Model for PLUTO 50/FN. Max 442 in-lb.
800320	1/4" - 3/8"	Model for PLUTO CA/FN2. Max 133 in-lb.
800321	3/8" - 3/8"	Model for PLUTO20 and PLUTO35. Max 310 in-lb.
800322	1/4" - 1/4"	Model for PLUTO FR/FN and MITO /FN. Max 62 in-lb.
<b>Vacuum attachments</b>		
010111/1	A2	For non-magnetic M2-M2.6 screws. It can be installed on any screwdriver.
010111/2	A3	For non-magnetic M3-M4 screws. It can be installed on any screwdriver.
010121	ASP HD9	Rubber pad output. Best suited for round-headed screws. Model specifically designed for PLUTO3, PLUTO6, PLUTO10 and PLUTO15.
010121/UNI	ASP HD9/UNI	Metal tube output. Best suited for grub, allen and long screws. Model specifically designed for PLUTO3, PLUTO6, PLUTO10 and PLUTO15.
<b>Autocatchers</b>		
010113	AC 2.3	For M2-M3 screws. Easily picks up non-magnetic screws with a small plastic clamp.
010114	AC 3.5	For M3-M5 screws. Easily picks up non-magnetic screws with a small plastic clamp.
<b>Cables (to connect screwdriver to controller)</b>		
200063	98 in	Standard 5 pin cable for PLUTO CA series – included with screwdriver
250063/N	98 in	Standard 8 pin cable for PLUTO CA/TA (Torque & Angle) series – included with screwdriver
200063/H	98 in	5 pin cable with strain relief for PLUTO CA series – heavy duty applications
250063/H	98 in	8 pin cable with strain relief for PLUTO CA/TA (Torque & Angle) series – heavy duty applications
200563	197 in	5 pin cable, 197 in length for PLUTO CA series
250563	197 in	8 pin cable, 197 in length for PLUTO CA/TA (Torque & Angle) series
200563/S	197 in	5 pin spiral cable for PLUTO CA series
250563/S	197 in	8 pin spiral cable for PLUTO CA/TA (Torque & Angle) series





Accessories for NATO and MITO Screwdrivers

Code	Model	Description
<b>Flange mount kit</b>		
800406	1/4" - 1/4" kit for 04-15	An 1/4" - 1/4" flange mount kit turns a MITO CA screwdriver into MITO CA/FN.
<b>Telescopic spindle</b>		
800322	1/4" - 1/4"	Model for MITO /FN. Max 62 in-lb.
<b>Vacuum attachments</b>		
010111/1	A2	For non-magnetic M2-M2.6 screws. It can be installed on any screwdriver.
010111/2	A3	For non-magnetic M3-M4 screws. It can be installed on any screwdriver.
010117	ASP HD6	Rubber pad output. Best suited for round-headed screws. Model specifically designed for NATO15.
010117/UNI	ASP HD6/UNI	Metal tube output. Best suited for grub, allen and long screws. Model specifically designed for NATO15.
010118	ASP HD7	Rubber pad output. Best suited for round-headed screws. Model specifically designed for NATO50.
010118/UNI	ASP HD7/UNI	Metal tube output. Best suited for grub, allen and long screws. Model specifically designed for NATO50.
010119	ASP HD8	Rubber pad output. Best suited for round-headed screws. Model specifically designed for MITO15.
010119/UNI	ASP HD8/UNI	Metal tube output. Best suited for grub, allen and long screws. Model specifically designed for MITO15.
<b>Autocatchers</b>		
010113	AC 2.3	For M2-M3 screws. Easily picks up non-magnetic screws with a small plastic clamp.
010114	AC 3.5	For M3-M5 screws. Easily picks up non-magnetic screws with a small plastic clamp.
<b>Cables (to connect screwdriver to controller)</b>		
200063	98 in	Standard 5 pin cable for NATO and MITO series – included with screwdriver
250063/N	98 in	Standard 8 pin cable for NATO and MITO /TA (Torque & Angle) series – included with screwdriver
200063/H	98 in	5 pin cable with strain relief for NATO and MITO series – heavy duty applications
250063/H	98 in	8 pin cable with strain relief for NATO and MITO /TA (Torque & Angle) series – heavy duty applications
200563	197 in	5 pin cable, 197 in length for NATO and MITO series
250563	197 in	8 pin cable, 197 in length for NATO and MITO /TA (Torque & Angle) series
200563/S	197 in	5 pin spiral cable for NATO and MITO series
250563/S	197 in	8 pin spiral cable for NATO and MITO /TA (Torque & Angle) series



Accessories for KDU series controllers (KDS Transducerized screwdrivers)

Code	Model	Description
<b>Connection devices</b>		
020046	DOCK 05	Dual output connector for KDS screwdrivers, to be used with KDU units. Run two drivers with one controller (not simultaneously).
020078	UR® Robot connection device	Plug-in device for connecting UR® Robot and KDU controllers.
020051	2D Barcode reader	KDU units can also be controlled via a barcode reader. Scan the right barcode (either 1D or 2D, such as QR codes) to select the correct program.
010410	Adaptor kit SW CBS	Adaptor device for connecting KDU-1A and SWBX88 switchbox or CBS880 socket tray.
020082	Light tower stack	A light stack makes output signals clearly visible. Supplied standard with 98 in cable and 10 pin connector for KDU.

Accessories for EDU2AE series controllers (PLUTO Screwdrivers)

Code	Model	Description
<b>Program selection – To be used with EDU2AE/TOP, EDU2AE/TOP/E or EDU2AE/TOP/TA (multiprogram controllers).</b>		
020033	SWBX88 Switchbox	Select the right pre-set program by simply pushing a button. 8-program selection.
020042	CBS880 Socket tray	When a bit or socket is removed from the tray, the control unit automatically selects the pre-set program. 8-program selection.
020050	BRCR90 Barcode reader	Multiprogram units can also be controlled via a barcode scanner. Scan the right barcode to select the correct pre-set program.
<b>Dual output connector</b>		
020045	DOCK 04	Dual output connector for PLUTO Series, to be used with EDU2AE/TOP. Run two drivers with one controller (not simultaneously).
020045/TA	DOCK 04/TA	Dual output connector for PLUTO TA Series, to be used with EDU2AE/TOP/TA. Run two drivers with one controller (not simultaneously).
<b>Remote start and reverse</b>		
020070	Start / Reverse pedals	Start and reverse signals can be activated using a foot pedal. Supplied standard with 138 in cable and connector for any EDU2AE controller.
<b>Data printer</b>		
020026	PRNTR1 Serial printer	Instantly print each screw tightening result via a serial printer. It connects directly to multiprogram units and K and Mini K/S torque testers.
<b>Connection devices</b>		
020075	Ethernet device	Connect your PC to any EDU2AE/TOP, EDU2AE/TOP/E or EDU2AE/TOP/TA via remote LAN connection using an ethernet device.
020077	UR® Robot connection device	Plug-in device for connecting UR® Robot and EDU2AE/TOP, EDU2AE/TOP/E or EDU2AE/TOP/TA controllers.
<b>Visual signals</b>		
020080	Light tower stack	A light stack makes output signals clearly visible. Supplied standard with 2.5 cable and 10 pin connector for EDU2AE series.
020081	Light tower stack	A light stack makes output signals clearly visible. Supplied standard with 98 in cable and 10 pin connector for EDU2AE/TOP and TOP/TA.

Accessories for EDU1FR series controllers (FAB & RAF Screwdrivers)

Code	Model	Description
<b>Dual output connector</b>		
020020	DOCK 01	Dual output connector for EDU1FR controllers. Run two drivers with one controller. Drivers cannot be used at the same time.
<b>Screw counting device</b>		
020021	ACE	Screw counting device for EDU1FR/SG controller. It keeps track of either correct and wrong tightenings, as well as cycles and sequences.

Accessories for EDU1BL series controllers (KBL Screwdrivers)

Code	Model	Description
<b>Dual output connector</b>		
020035	DOCK 02	Dual output connector for EDU1BL controllers. Run two drivers with one controller. Both drivers can be used at the same time.
020035/S	DOCK 02/S	Dual output connector for EDU1BL/SG controllers. Run two drivers with one controller. Drivers cannot be used at the same time.
<b>Screw counting device</b>		
020022	ACE	Screw counting device for EDU1BL/S i c o n t r o l l e r s . I t k e e p s t r a c k o f e i t h e r c o r r e c t a n d w r o n g t i g h t e n i n g s , a s w e l l a s c y c l e s a n d s e q u e n c e s .



#### KOLVER NORTH AMERICA

In 2002 Kolver North America was founded in Salem, NH with the intent to provide superior products and service to North American customers. Covering the U.S., Mexico, Canada and the Caribbean we stand by the motto "our commitment to our customers is a commitment to excellence".

The Kolver® family of tools is one of the most comprehensive in the electric power tool industry covering a wide range of torque at several speeds, suitable for an infinite number of applications. We are also a leader in the industry 4.0 revolution, rising to the challenge of even the most challenging customer applications.

If you are looking for a long lasting, cost effective solution along with excellent customer support in North America then look no further than Kolver North America!

#### OUR COMPANY

Founded in 1989, KOLVER® has soon taken the leadership in the European market of precision electric screwdrivers for industry. Thousands of state-of-the-art drivers are produced every year in Italy and then shipped to more than 50 countries worldwide.

ISO 9001 certified since 1998, KOLVER® has gained international recognition for building premier quality innovative products that meet or even anticipate the most rigorous customer requirements.

Kolver® tools feature either transducerized, shut off clutch or current control system, coreless or brushless motors all controlled by a state-of-the-art electronic control unit. Thanks to their low installation, operating and maintenance costs as well as to their reduced vibration and noise level, Kolver® electric screwdrivers represent the perfect alternative to pneumatic screwdrivers for screws up to M10.

## KOLVER NORTH AMERICA

8D Industrial Way, Suite 1 - Salem, NH 03079  
P (603) 912-5886 - F (978) 923-8522  
kolver@kolver.com - kolver.com

## KOLVER®

Via Marco Corner, 19/21 - 36016 Thiene - Italy  
Tel. +39 0445 371068  
kolver@kolver.it - kolver.com



#### ONE YEAR LIMITED WARRANTY

KOLVER® products are guaranteed against defective workmanship or materials, for a maximum period of 12 months following the date of purchase from KOLVER®, provided that its usage is limited to single shift operation throughout that period.

If the usage rate exceeds that of single shift operation, the guarantee period shall be reduced on a prorata basis. If, during the guarantee period, the product appears to be defective in workmanship or materials, it should be returned to KOLVER® or its distributors, transport prepaid, together with a short description of the alleged defect. KOLVER® shall, at its sole discretion, arrange to repair or replace free of charge such items. This guarantee does not cover repair or replacement required as a consequence of products which have been abused, misused or modified, or which have been repaired using not original KOLVER® spare parts or by not authorized service personnel. KOLVER® accepts no claim for labour or other expenditure made upon defective products. Any direct, incidental or consequential damages whatsoever arising from any defect are expressly excluded. This guarantee replaces all other guarantees, or conditions, expressed or implied, regarding the quality, the marketability or the fitness for any particular purpose. No one, whether an agent, servant or employee of KOLVER®, is authorized to add to or modify the terms of this limited guarantee in any way. However it's possible to extend the warranty with an extra cost.



ISO 9001 certified since 1998

Due to our policy of continuous product improvement at KOLVER®, the design, data and specifications are subject to change without prior notice.

02/2024 © Copyright Kolver Srl. All rights reserved.

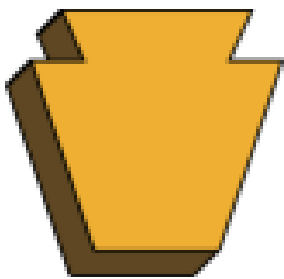

# KEYSTONE

ASSEMBLY SOLUTIONS, LLC

401 West King Street, East Berlin, PA 17316

Advanced Assembly, Critical Torque  
& Ergonomic Handling Systems

844-KAS-TOOL - (844.527.8665)

[www.keystoneassembly.com](http://www.keystoneassembly.com)



## KOLVER® SRL

B. Corp. - Via Marco Corner, 19/21  
36016 Thiene - Italy  
Tel. +39 0445 371068  
[kolver@kolver.it](mailto:kolver@kolver.it) - [kolver.com](http://kolver.com)



LinkedIn



Facebook

## KOLVER NORTH AMERICA

8D Industrial Way, Suite 1  
Salem, NH 03079  
P (603) 912-5886 - F (978) 923-8522  
[kolver@kolver.com](mailto:kolver@kolver.com) - [kolver.com](http://kolver.com)



LinkedIn



YouTube

**MORE QUALITY THAN YOU MAY EVER NEED**