

McKee Craft

THE UNSINKABLES



2003

McKee Craft

The Unsinkables!

When you purchase a McKee Craft, you don't just buy a boat, you buy a company. We believe unsurpassed safety and reliability must be the backbone of every boating experience. Our passion for boats and the families who own them is reflected in the way every McKee Craft stands up to the toughest conditions and is *unsinkable*.

History

In 1966, after extensive testing and trials, Lanness McKee discovered the secrets of unsinkable marine construction by pressure foam filling. The process of foam fusing every square inch of the deck and hull enables us to build a boat without stringers and spars. This one piece design offers virtually no flex, is quiet in the water and exceeds the strength of any boat built with conventional wood or fiberglass stringer systems. Don't take our word for it, just ask any one of our over 30,000 McKee Craft owners. Or better yet, listen to the experts. Over 1,500 McKee Craft boats are currently in service with local, state and federal agencies who are protecting our waters.

Quality

McKee Craft products reflect the commitment to our customers and their families. Only time-tested quality materials are used. Hulls are strengthened at key points with syntactic core and the decks are strengthened with a poly/ceramic core the strength of solid oak. Every hull comes with a 10-year limited warranty. These are just a few of the reasons why McKee Craft boats maintain a high resale value—and many are passed down from generation to generation.

The Smart Choice

McKee Craft has earned a reputation for being the smart choice for avid boating families who love to fish. Why? Because our boats are practical, durable and easy to maintain. We have put over four decades of fishing experience into each McKee Craft, so you can count on having a generous list of standard equipment and the features you need.

We invite you to visit your local dealer for a sea trial, or contact us directly for more information. Call us today at 910-628-0926, or visit us at www.mckeecraft.com.

Go Fish!
The McKee Craft Team

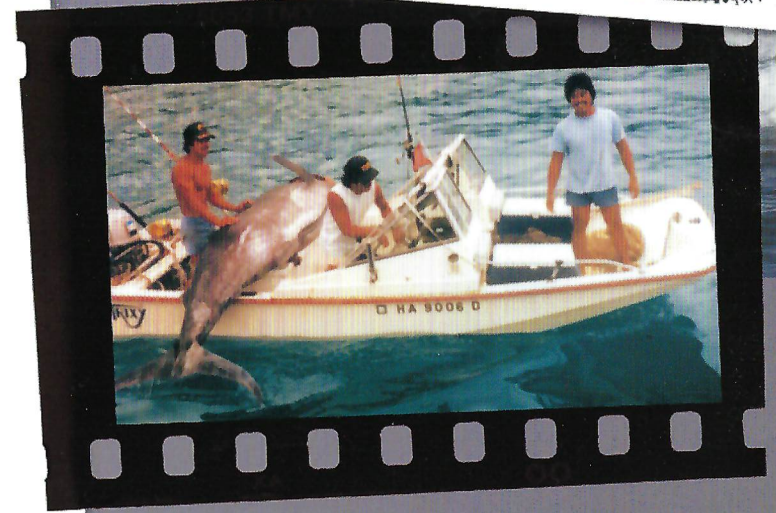
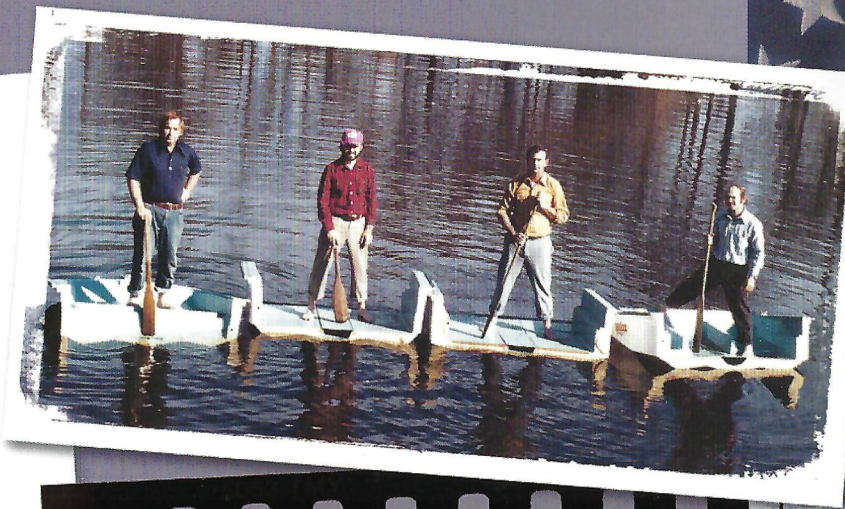
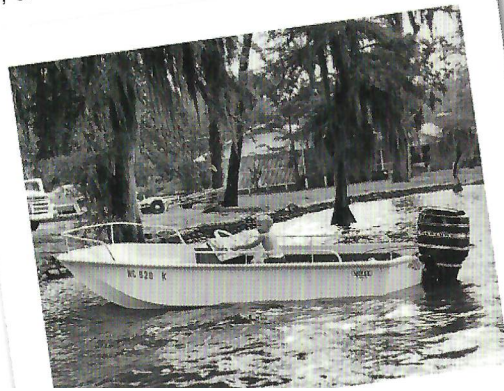



McKee Craft, Inc.
P.O. Box 623
Fairmont, NC 28340

Dear Sir:

How tough is a 14' McKee boat supposed to be?

With a crushed bow and shattered side, rub rails pulled loose to act as a second sea anchor, five men aboard—water, gas & supplies; is it supposed to withstand the hammering of 30' waves in a full gale for 37 hours and not disintegrate? Well, we thank God you build a boat with that hidden bonus of integrity that keep it intact in spite of the above abuse and misuse.

When my 47' motor sailer, the Tiki, foundered after 2 days in a full gale beating off the Grand Bahama Shoals, we took to the life boat. After we sent out our Mayday, we spent 2 hours putting gear aboard and where possible tying it down...

To stow these things, one man was aboard with two men pulling the McKee up to the stern and two men above slinging gear aboard. Time and again the stern rub rail of the ketch crashed down on the bow of the McKee—all 20 tons—splintering the bow and stern no matter how we tried to fend it off. The waves were 30 feet or higher, the wind at 60 on my anemometer – it was a wild sea. One side swipe splintered the right side of the bow sheering off a piece 10 inches by 2 feet from the outside fiberglass covering, exposing the floatation material...

As the U.S. Coast Guard said to my sons 24 hours after the Tiki sank, "There is no use our continuing this search; no small boat could possibly survive in the cross seas in a Gulf Stream gale of this magnitude." Little did they know of your great design, how well she responded to a quick turn of motor to avoid a cresting, crashing wave and how her structure could hold together under the incessant pounding of tremendous, solid seas.

We eventually ran out of gas...having traveled right through the teeth of the gale. Five hours later, 10 miles further out, and some 20 miles further north, we were picked up by the SS Texaco Nebraska and...taken aboard, two by stretcher, one unconscious and three of us still on our feet.

All of us are grateful I picked a McKee boat as a tender and life boat we're further grateful you people really know how to build a boat with that extra integrity that made it so much more durable than we could reasonably expect.

Sincerely yours

S.M. "Bus" Huestis

Captain & owner of the late Tiki and survivor

By the Grace of God, The SS Texaco Nebraska
and the Builders of the McKee Craft.

Construction

At McKee Craft, we're constantly striving to make the most practical, fishable boat on the water. Why? Because our customers make smart decisions, demanding rugged, well appointed, easily serviced boats that include the safety features and unsinkable construction built into every McKee Craft. That's why McKee Craft Customers keep their boats an average of 15 years.

Flotation

Most 18' boats require only 80 lbs of foam to meet US Coast Guard requirements for level flotation and 125 pounds to fill the hull... but, we pack it in, under pressure using 200 lbs. That is more than two and a half times the requirement set by the US Coast Guard. The foamed boat is also allowed to cure overnight in the mold. During our in-mold construction cycle, some competitor's molds have already built as many as 2 boats during the same 48 hours. That's why our dimensional stability is like no other boat on the market.

100% Unsinkable Construction

Safety is the reason why each and every McKee Craft boat features our unsinkable construction. McKee Craft takes that requirement to the next level: our boats will not only float, but also remain upright in calm water, even if the boat is cut in half.

Hull PBS™ System

McKee Craft boats do not have stringers. We utilize a totally unique construction method we call "PBS," our Pressure Bonding System. This unique method of construction allows the strength of the deck to combine with the strength of the hull, both complimenting each other, resulting in the most rugged hulls in the industry.

One tough, superbly

Beauty is More Than Skin Deep

Inside every McKee Craft is a story that you can't see. It is the passion that drives our team to design, engineer, and manufacture to the highest standards... the heart that understands the importance of family time, memories of time on the water, the first big catch...and the peace of mind knowing that your boat is safe and unsinkable.

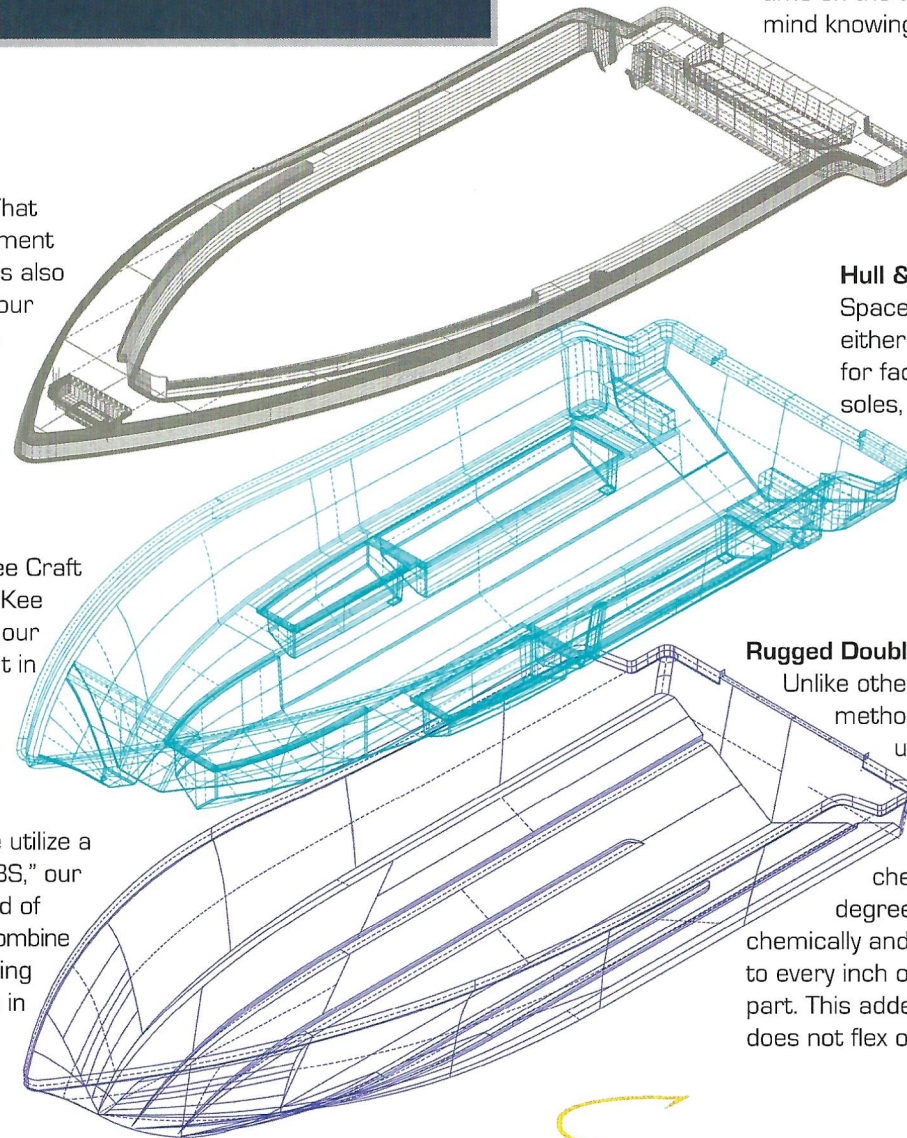

Hull & Deck Joint

Space-age composites are used in key areas with either rigid 1/2" thick polyethylene or aluminum plating for factory installed equipment like cleats, rails, consoles, and seats. The hull and deck are then bonded together with top-of-the-line ATC B39 bonding putty which ensures a complete rather than spot bond of the hull deck joint.

Rugged Double Hull Construction

Unlike other manufacturers, McKee Craft utilizes a unique method of injecting flotation foam into our boats. We use specially formulated polyurethane foam that expands to 50 times its original volume in less than a minute. Pressure rises rapidly to as much as 150,000 pounds on an 18' boat, the chemical reaction creating heat that peaks at 240 degrees. The combination of heat and intense pressure chemically and mechanically bonds every square inch of the hull to every inch of the deck. The two pieces become one integral part. This added rigidity means that the hull is stronger and does not flex or twist in rough water conditions.

built, unsinkable fishing boat.



Quality is built-in rather than being a "checklist" to be used at the end of the production line. The first step is the gelcoat, sprayed by highly trained craftsmen and checked to ensure the coverage is just right.



Premium ISO/NPG gelcoat is used to create a smoother profile while improving durability.



The fiberglass ISO/DCPD ratio is precision machine metered. Highly trained lamination technicians hand-roll the fiberglass to create uniform, consistent hull profiles.

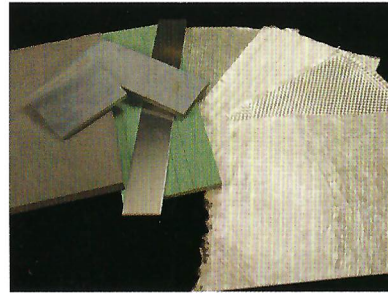

Every boat is constructed of 100% composite materials... not just woodfree hulls, but the decks, seats and cushions as well. Transoms, decks, and keels are cored and reinforced with lightweight super-strong polymeric materials.



Top quality transom composites are embedded into the wet laminate on the hull. Then the composite transom is completely encapsulated in fiberglass for added strength.



Fuel tanks are high quality welded aluminum with interior baffles to keep the fuel from shifting too quickly which might affect the balance of the boat. All below deck fuel tanks are foamed in place and primed with Zinc Chromate for greater resistance to corrosion.

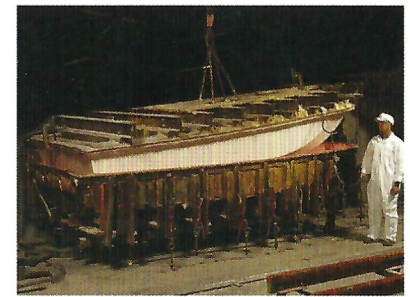

Each McKee Craft hull stays in the mold for a full 48 hours to ensure a full cure for the best dimensional stability and cosmetic finish. Many manufacturers cycle molds twice a day or more which can hamper quality, distort or even twist hulls.



McKee Craft utilizes ISO-NPG gelcoat, which has high flex properties that are resistant to cracking, and titanium dioxide pigments that are the most UV stable pigments available. This keeps the finish and colors looking beautiful for years to come.



Quality and craftsmanship are built-in from the start. Where you can see it, and where you can't, you can trust that quality is inside every inch of your McKee Craft boat

28 Freedom CC

SPECIFICATIONS

Overall Length	28'
Beam	9'-11"
Draft	22"
Approx. Boat Weight	5500 lbs
Persons Capacity	10
Maximum Power	600 hp
Recommended Power	450 hp
Minimum Power	400 hp
Transom Height	30"
Fuel Capacity	265 gal
Deadrise at Transom	24.5°
Interior Freeboard	26"



STANDARD FEATURES

Hull and Deck

- 100% Unsinkable - PBS™ pressure foam filled construction
- 10-year limited structural hull warranty
- Bow eye, stainless steel
- Cleat, bow, 8" pop-up, stainless steel
- Cleats, springline, 8" pop-up, (2), stainless steel
- Cleats, stern, 8" pop-up, (2) stainless steel
- Color hull sides (7) selections
- Complete Vinyl Ester skin coat (interior and outer hull)
- Fiberglass deck with patterned anti-skid surface
- Functional flush deck design
- Helm, generous space for installation of after-market electronics
- Pop-up anchor chocks, stainless steel
- Rubrail, heavy duty vinyl, reinforced, Uni-flex
- Storage, all boxes are completely insulated
- Transom, full height with door
- Transom lifting eyes, (2) heavy duty stainless steel

Fishability

- Livewell, 52 gal, LED lighted
- Livewell pumps, (2) 800 GPH SHUR-Flo®
- Outriggers are deployable from under T-top
- Rod holders, (4) flushmount, stainless steel
- Rod holders, (5) transom mount
- Rod racks, (8) removable from fishbox, lockable
- Tackle box, two drawer
- Tackle center, (3) drawer

Mechanical

- Battery storage area
- Bilge pump, (2) 550 GPH each with automatic float switches
- Cockpit courtesy lights, LED
- Deck accessible battery switch box in console
- Florescent all around lighting, mounted on T-top
- Fore and aft spreader lights
- Fresh and saltwater washdown with retractable hose coils
- Fresh water system, 20 gal, with SHUR-Flo® pressure pump
- Fuel tank, welded aluminum, 265 gal fully accessible and serviceable
- Manual and macerated fishbox drainage
- Navigation lights
- Pneumatic lift assist rams on all fishboxes, stainless steel
- Raw water washdown system with SHUR-Flo® pressure pump
- Steering system, tilt hydraulic
- Steering wheel with power knob, offshore style polished stainless steel
- Wiring system, multifunction w/breaker panel & accessory fuse block

"The Department runs several well known brands of boats. When it gets really rough and most boats are coming in, we're just going out. I choose McKees every time for the safety, dry ride, and comfort."

**Rowland Turner, Deputy Sheriff,
Charleston County Sheriff's Office**

Console Features

- 2" toe kick around console base
- Electronics box, integrated into console, lockable
- Electronics security cover, Plexiglas, lockable
- Glovebox, lockable
- Portable head area, lockable
- Recessed fire extinguisher pocket
- Sturdy grab rail, integrated in T-top design
- Windshield, Plexiglas

Cockpit

- 4½" toe kick 360° around the cockpit
- 360° wraparound cockpit bolsters
- Anchor locker, recessed
- Bow rails elliptical recessed, stainless steel
- Cambered floor for rapid self-bailing
- Cockpit drains with flapper valve, stainless steel
- Foldaway aluminum bow step
- Foldaway aluminum leaning post footrest
- Leaning post with backrest and grabrail
- Transom door with stainless steel latch
- T-top with outriggers and electronics box, factory installed
- Twist latches on all box lids, stainless steel

Storage

- Anchor locker
- Bow storage box, insulated, 740 qt
- Fishboxes, (2) insulated, 140 qts each
- Fishboxes, (2) insulated, 240 qts each
- T-top life jacket storage bag



SHOWN WITH OPTIONAL EQUIPMENT

OPTIONS

- Boarding ladder, 3-step, removable
- Canvas, Sunbrella® & Stratglass™ (30 gauge) Gull wing kit (requires spray kit)
- Canvas, Sunbrella® & Stratglass™ (30 gauge) spray curtain kit
- Compass, 3" flushmount, illuminated
- Foldaway rear bench seat with backrest
- Sailfish clamp-on outriggers

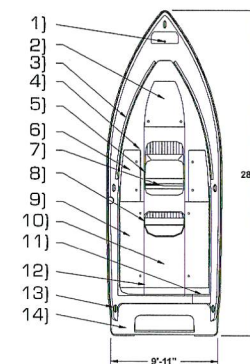

- 1) INTEGRATED ANCHOR LOCKER
- 2) 740 QT. INSULATED STORAGE BOX
- 3) STAINLESS STEEL GRAB RAIL
- 4) 115 SQ. FT. COCKPIT AREA
- 5) LARGE CONSOLE WITH WALK-IN AREA FOR HEAD / STORAGE
- 6) (2) 140 QT. INSULATED FISH / STORAGE BOX
- 7) INTEGRATED ELECTRONICS BOX
- 8) INTEGRATED LEANING POST WITH 52 GAL. LIVEWELL
- 9) (2) 240 QT. INSULATED FISH / STORAGE BOX
- 10) 265 GAL. BELOW DECK FUEL TANK
- 11) INTEGRATED TRANSOM DOOR
- 12) SELF-BAILING DECK DESIGN
- 13) (5) STAINLESS STEEL 8" POP-UP CLEATS
- 14) INTEGRATED TRANSOM PLATFORM

CONSOLE



52 GAL LIVEWELL



7' FISHBOX & RODHOLDERS

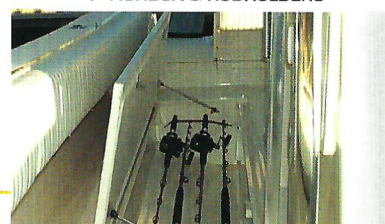

McKee Craft
www.mckeecraft.com THE UNSINKABLES

22 Runaway CC



SPECIFICATIONS

Overall Length	22'-9"
Beam	8'-6"
Draft	19"
Approx. Boat Weight	2650 lbs
Max. Weight Capacity	1750 lbs
Swamped Capacity	3600 lbs
Persons Capacity	8
Maximum Power	250 hp
Recommended Power	200 hp
Minimum Power	150 hp
Transom Height	25" / 20"
Fuel Capacity	100 gal
Deadrise at Transom	18°
Interior Freeboard	25"

STANDARD FEATURES

Hull and Deck

- 100% Unsinkable - PBS™ pressure foam filled construction
- 10-year limited structural hull warranty
- All storage boxes completely insulated
- Anchor pulpit with roller
- Bow eye, stainless steel
- Cleat, bow, 6" stainless steel
- Cleats, springline, 6" (2), stainless steel
- Cleats, stern, 6" pop-up (2) stainless steel
- Fiberglass deck with patterned anti-skid surface
- Meets or exceeds all applicable U.S. Coast Guard safety standards
- Rubrail, heavy duty vinyl, reinforced, Uni-flex
- Transom lifting eyes, (2) stainless steel
- Vinyl Ester skin coat on outer hull

Fishability

- Forward casting deck, snag-free
- Livewell, 34 gal, LED lighted
- Livewell pump, 550 GPH
- Rod holders, (4) flushmount, stainless steel
- Tackle center, (6) drawer

Storage

- Anchor locker
- Fishbox, full-beam insulated, 240 qt
- Fishbox, insulated, 200 qt
- Transom utility storage areas, (2)

Mechanical

- Battery storage area
- Bilge pump, (2) 550 GPH each with automatic float switch
- Cockpit courtesy lights
- Fuel tank, welded aluminum, 100 gal
- Navigation lights
- Raw water washdown system with SHUR-Flo® pressure pump
- Steering system, tilt hydraulic
- Wiring system, multifunction w/ breaker panel & accessory fuse block

Console Features

- 2" toe kick around console base
- Electronics box, integrated, lockable
- Glovebox, lockable
- Portable head area, lockable
- Rail, console, stainless steel
- Recessed fire extinguisher pocket
- Windshield, Plexiglas

"To say the Runaway is rugged would be an understatement..."
MotorBoating Magazine

Cockpit

- Bow rail, wraparound, stainless steel
- Cambered floor for rapid self-bailing
- Cockpit drains with 4 way flapper valve, stainless steel
- Leaning post, with oval livewell, 34 gal
- Space maximizing transom design
- Twist latches on all box lids, stainless steel

OPTIONS

- Bimini top, Sunbrella® w/ stainless steel hardware & fasteners
- Canvas, Sunbrella® & Stratglass™ (30 gauge) Gull wing kit [requires spray kit]
- Canvas, Sunbrella® & Stratglass™ (30 gauge) spray curtain kit
- Cockpit bolsters
- Colored hull sides (7) selections
- Compass, 3" flushmount, illuminated
- Fiberglass, boarding platform w/ two step ladder
- Foldaway aluminum leaning post footrest
- Foldaway rear jump seats
- Leaning post backrest and grabrail
- Seat, Tempress® bow fishing chair, removable
- T-top life jacket storage bag
- T-top with lockable electronics box, factory installed
- T-top with outriggers and electronics box, factory installed
- Trim tabs, Lenco



SHOWN WITH OPTIONAL EQUIPMENT

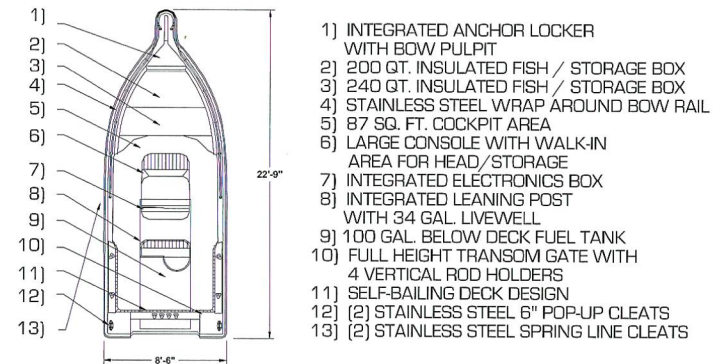

ENCLOSED HEAD



TRANSOM ROD HOLDER



TACKLE CENTER



McKee Craft
www.mckeecraft.com THE UNSINKABLES

1800 Pulse CC

SPECIFICATIONS

Overall Length	18'-3"
Beam	7'-10"
Draft	17"
Approx. Boat Weight	1500 lbs
Max. Weight Capacity	1850 lbs
Swamped Capacity	3000 lbs
Persons Capacity	8
Maximum Power	175 hp
Recommended Power	125 hp
Minimum Power	115 hp
Transom Height	25"
Fuel Capacity	64 gal
Deadrise at Transom	18°
Interior Freeboard	21"



STANDARD FEATURES

Hull and Deck

100% Unsinkable - PBS™ pressure foam filled construction
 10-year limited structural hull warranty
 Bow eye, stainless steel
 Cleat, bow, 6" stainless steel
 Cleats, stern, 6" (2), stainless steel
 Fast/dry - reverse lifting strake hull design
 Fiberglass deck with patterned anti-skid surface
 Functional European design transom
 Meets or exceeds all applicable U.S. Coast Guard safety standards
 Rubrail, heavy duty vinyl, reinforced, Uni-flex
 Storage, all boxes completely insulated and drain directly overboard
 Transom lifting eyes, (2) stainless steel

Fishability

Casting deck, large raised area in bow
 Livewells, (2) round 52 qt
 Livewell pump, 950 GPH
 Raw water washdown system
 Rod holders, (4) flushmount, stainless steel
 Rod storage, (4) vertical
 Tackle center, (4) drawer

Storage

Anchor locker
 Console seat, storage, 44 qt
 Dry utility storage area under consoles, lockable
 Fishbox, insulated full-beam, 168 qt

Mechanical

Battery storage area in console
 Bilge pump, 550 GPH with automatic float switch
 Deluxe backlit multifunction switch panel and wiring system
 Fuel tank, welded aluminum, 64 gal
 Fuse block, ATO style
 Horn, flushmount
 Navigation lights
 Steering, Uflex Rotech® Planetary Gear design

Cockpit

Cambered floor for rapid self-bailing
 Cockpit drains with flapper valve
 Rails, bow, curved, stainless steel 4' x 4"
 Seat, swingback with 72 qt cooler

"I bought my 1800 Pulse for its safety and styling. I kept it for its durability and value."
Lyle Strong, NC

Console Features

Cockpit lights
 Console, deluxe center design
 Console, storage with large access door, lockable
 Dash, ergonomic angles and rounded corners
 Glovebox, lockable
 Rail, console, stainless steel
 Rail, passenger handrail, stainless steel
 Raised inner floor provides dry storage
 Seat, forward of console with 44 qt storage & cushion
 Steering wheel, ultra-grip five spoke, stainless steel
 Windshield, Plexiglas

OPTIONS

Bimini top, Sunbrella® w/ stainless steel hardware & fasteners
 Boarding ladder, 2 step, w/ handrail stainless steel
 Bow/ lifting eye, stainless steel
 Colored hull sides (7) selections
 Compass, 3" flushmount, illuminated
 Cushion, bow foldable to access fishbox
 Cushion, gunnel bolsters
 Cushions, livewell seat & backrest, (requires below)
 Cushion, stern, with SX rail, center flip-up seat & backrest
 Fiberglass, gunnel board upgrade
 Leaning post
 Rails, bow, stainless steel, SX style 8' x 6"
 Rails, bow, stainless steel wraparound
 Rails, side, stainless steel 2' x 4"
 Rails, side, stainless steel 4' x 4"
 Rails, side, stainless steel 6' x 6"
 Rails, stern, stainless steel, SX style, full-beam
 Seat, Captain's chairs (2) upgrade
 Seat, Tempress® bow fishing chair, removable
 Steering upgrade, tilt hydraulic
 Trolling motor wiring kit (plug & 10" light)
 T-top



POWERED BY:
EVINRUDE

XS SPORT PACKAGE FEATURES INCLUDE:

Beverage holder, (2)
 Carbon fiber-look dash panel
 Cockpit courtesy light, LED*
 Colored hull sides (7) selections
 Cushion, bow, foldable to access fishbox
 Cushion, livewell seat & backrest
 Cushion, stern w/ SX rail, center flip-up seat & backrest
 Fiberglass gunnel boards with bolsters
 Livewells, (2) oval 52 qt, LED lighted
 Rails, side, stainless steel 8' x 6"*
 Raw water washdown system with stainless steel fitting*
 Seat, stainless frame, 5-position backrest & 72 qt cooler*
 Trolling motor wiring kit (plug & 10" light)

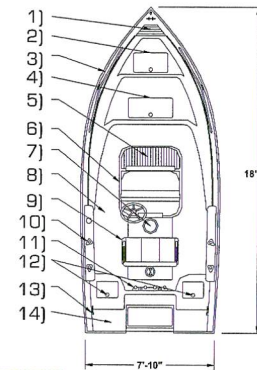

- 1) INTEGRATED CUTTING BOARD
- 2) 56 QT. INTEGRATED ANCHOR LOCKER
- 3) STAINLESS STEEL BOW RAIL
- 4) 168 QT. STORAGE / FISH BOX
- 5) 44 QT CONSOLE STORAGE
- 6) LOCKABLE CONSOLE STORAGE
- 7) 64 GAL. BELOW DECK FUEL TANK
- 8) 63 SQ. FT. COCKPIT AREA
- 9) 72 QT. SWING BACK COOLER SEAT
- 10) S.S. GUNNEL MOUNT ROD HOLDERS
- 11) VERTICAL ROD RACK
- 12) DUAL 52 QT. AERATED LIVEWELLS
- 13) (3) STAINLESS STEEL 6" CLEATS
- 14) INTEGRATED SWIM PLATFORM

TACKLE CENTER



BOARDING LADDER



DUAL 52 QT LIVEWELLS

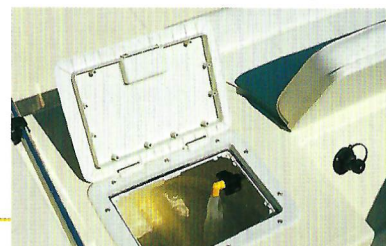

McKee Craft
 www.mckeecraft.com THE UNSINKABLES

1800 Pulse DC

SPECIFICATIONS

Overall Length	18'-3"
Beam	7'-10"
Draft	17"
Approx. Boat Weight	1500 lbs
Max. Weight Capacity	1850 lbs
Swamped Capacity	3000 lbs
Persons Capacity	8
Maximum Power	175 hp
Recommended Power	125 hp
Minimum Power	115 hp
Transom Height	25"
Fuel Capacity	64 gal
Deadrise at Transom	18°
Interior Freeboard	21"



STANDARD FEATURES

Hull and Deck

- 100% Unsinkable - PBS™ pressure foam filled construction
- 10-year limited structural hull warranty
- Bow eye, stainless steel
- Cleat, bow, 6" stainless steel
- Cleats, stern, 6" (2) stainless steel
- Dual console design with wraparound windshield
- Fast/dry - reverse lifting strake hull design
- Fiberglass deck with patterned anti-skid surface
- Functional European design transom
- Meets or exceeds all applicable U.S. Coast Guard safety standards
- Rubrail heavy duty vinyl, reinforced, Uni-flex
- Storage, all boxes completely insulated and drain directly overboard
- Transom lifting eyes, (2) stainless steel

Fishability

- Casting deck, large raised area in bow
- Cockpit, large aft floor area for maximum fishability
- Livewells, (2) round 52 qt
- Livewell pump, 950 GPH
- Raw water washdown system
- Rod holders, (4) flushmount, stainless steel

Storage

- Anchor locker
- Dry console storage area under both consoles, lockable
- Fishbox, insulated full-beam, 168 qt

Mechanical

- Battery storage area
- Bilge pump, 550 GPH with automatic float switch
- Deluxe backlit multifunction switch panel and wiring system
- Fuel tank, welded aluminum, 64 gal
- Fuse block, ATD style
- Horn, flushmount
- Navigation lights

Console Features

- Cockpit lights
- Console designed for maximum weather protection
- Console grabrail, passenger side, stainless steel
- Console storage areas (2) with large access door, lockable
- Glovebox, lockable
- Steering wheel, ultra-grip five spoke, stainless steel
- Windshield, walk-through with tempered glass & aluminum frame

"We competed in two divisions of the SKA Tournament Trail this year qualifying for the Nationals in our McKee Craft against a fleet of much larger boats. If we can compete with 23, 27, 31 and 36' boats, then the family fisherman will delight in the performance, toughness and downright fishability of the 18' Pulse."

Jerold "Buck" Hall, Team Island Hopper

Cockpit

- Cambered floor for rapid self-bailing
- Cockpit drains with flapper valve
- Rails, bow, curved, stainless steel 4' x 4"
- Rear bench seat
- Seats, Captain's chairs (2) w/slides and cushions
- Sunbrella® center flap wind block

OPTIONS

- Boarding ladder, two step, w/handrail stainless steel
- Bow/lifting eye, stainless steel
- Colored hull sides (7) selections
- Compass, 3" flushmount, illuminated
- Cushion, bow (3 pc) foldable to access fishbox
- Cushion, gunnel bolsters
- Cushions, livewell seat & backrest, (requires below)
- Cushion, stern kit, includes SX stern rail, center flip-up seat & backrest
- Deluxe top, Sunbrella® w/ stainless steel hardware & fasteners
- Fiberglass, gunnel board upgrade
- Rails, side, stainless steel 2' x 4"
- Rails, side, stainless steel 4' x 4"
- Rails, stern, stainless steel, SX style, full beam
- Seat, lounge seat upgrade (portside exchange)
- Seat, Tempress® bow fishing chair, removable
- Side curtains, Sunbrella® for deluxe top
- Steering upgrade, tilt hydraulic
- Trolling motor wiring kit (plug & 10" light)

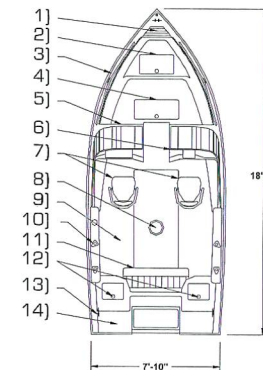

- 1) INTEGRATED CUTTING BOARD
- 2) 56 QT. INTEGRATED ANCHOR LOCKER
- 3) STAINLESS STEEL BOW RAIL
- 4) 168 QT. STORAGE / FISH BOX
- 5) PROTECTIVE DUAL CONSOLE DESIGN
- 6) LOCKABLE CONSOLE STORAGE
- 7) DELUXE PILOT CHAIRS
- 8) 64 GAL. BELOW DECK FUEL TANK
- 9) 63 SQ. FT. COCKPIT AREA
- 10) S.S. GUNNEL MOUNT ROD HOLDERS
- 11) REAR JUMP SEAT
- 12) DUAL 52 QT. AERATED LIVEWELLS
- 13) (3) STAINLESS STEEL 6" CLEATS
- 14) INTEGRATED SWIM PLATFORM

OPTIONAL BOW CUSHIONS



CONSOLE SEAT



REAR BENCH SEAT



McKee Craft
www.mckeecraft.com THE UNSINKABLES

185 Offshoreman CC

SPECIFICATIONS

Overall Length	18'-4"
Beam	7'-0"
Draft	11"
Approx. Boat Weight	1560 lbs
Max. Weight Capacity	1640 lbs
Swamped Capacity	2850 lbs
Persons Capacity	8
Maximum Power	150 hp
Recommended Power	90 hp
Minimum Power	70 hp
Transom Height	20"
Fuel Capacity	35 gal
Deadrise at Transom	18°
Interior Freeboard	19"



STANDARD FEATURES

Hull and Deck

- 100% Unsinkable - PBS™ pressure foam filled construction
- 10-year limited structural hull warranty
- Bow/lifting eye, stainless steel
- Cleat, bow, 6" recessed, stainless steel
- Cleats, stern, 6" recessed (2) stainless steel
- Fiberglass deck with patterned anti-skid surface
- Meets or exceeds all applicable U.S. Coast Guard safety standards
- Rails, bow wraparound, stainless steel
- Rubrail, heavy duty vinyl reinforced, Uni-flex
- Stable cathedral hull design
- Storage, all boxes completely insulated and drain directly overboard
- Transom lifting eyes, (2) stainless steel

Fishability

- Forward casting deck, 29 sq ft, snag-free
- Livewells, (2) oval 44 qt
- Livewell pump, 950 GPH
- Raw water washdown system
- Rod holders, (4) flushmount, stainless steel
- Rod storage, (4) vertical

Storage

- Anchor locker
- Console seat storage, 44 qt
- Dry console storage area, lockable
- Fishbox, insulated full-beam, 260 qt

Mechanical

- Battery box, in console
- Fuel tank, welded aluminum, 35 gal
- Navigation lights
- Steering, Uflex Rotech® Planetary Gear design
- Trim tabs, Lenco
- Wiring system, modular, expandable

Console Features

- Console deluxe center design
- Console storage with large access door, lockable
- Dash, ergonomic angles and rounded corners
- Glovebox, lockable
- Rail, console, stainless steel
- Rail, passenger handrail, stainless steel
- Raised inner floor provides dry storage
- Seat, forward of console, with cushion and 44 qt storage
- Steering wheel, ultra-grip five spoke, stainless steel
- Windshield, Plexiglas

SX STYLE GUNNEL BOARDS



"This is the first boat my family has owned that has enough storage space for a family outing!"
Hilary Byrd, New York

Cockpit

- Cambered floor for rapid self-bailing
- Cockpit drains with flapper valve, stainless steel
- Seat, swingback with cooler 72 qt
- Twist latches on all boxes, stainless steel

185 OFFSHOREMAN OPTIONS

- Bilge pump, 550 GPH with automatic float switch
- Bimini top, Sunbrella® with stainless steel hardware & fasteners
- Colored hull sides (7) selections
- Compass, 3" flushmount, illuminated
- Cushion, bow, foldable to access fishbox
- Cushion, gunnel bolsters
- Cushion, livewell with backrest
- Fiberglass, gunnel board upgrade
- Fiberglass, boarding kit w/two step ladder & handrail
- Fuse block, ATO style
- Leaning post
- Rails, side, stainless steel 2' x 4"
- Rails, side, stainless steel 4' x 4"
- Rails, side, stainless steel 6' x 6"
- Rails, side, stainless steel 9' x 6" (requires deleting bow rail)
- Rails, side, stainless steel 11' x 6" (requires deleting bow rail)
- Rails, stern, stainless steel, SX style
- Seat, Captain's chairs (2) upgrade
- Seat, Tempress® bow fishing chair, removable
- Steering upgrade, tilt hydraulic
- Tackle center (4) drawer
- Trolling motor wiring kit (plug & 10" light)
- T-top

SX CONSOLE



CONSOLE SEAT

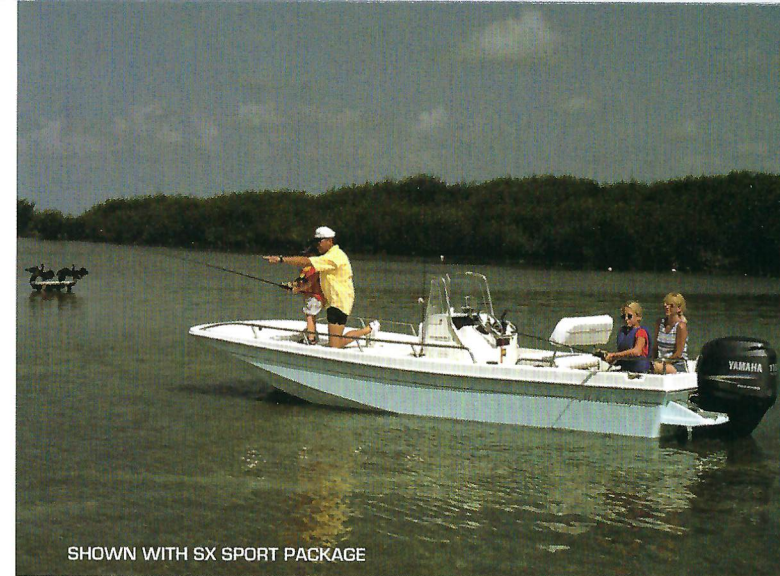

SHOWN WITH SX SPORT PACKAGE

SX SPORT PACKAGE FEATURES INCLUDE:

- Backlit multifunction switch panel and wiring system*
- Beverage holder, (2)
- Carbon fiber-look dash panel
- Colored hull sides standard (7) selections
- Cockpit courtesy light, LED*
- Cushion, livewell with backrest
- Fiberglass gunnel boards with bolsters
- Fuse block, ATO style
- Glovebox, lockable
- Horn, flushmount
- Livewells, (2) oval 44 qt, LED lighted*
- Pneumatic hatch lift assists, stainless steel
- Rails, corner stern, stainless steel
- Rails, side, stainless steel 11' x 6"*
- Raw water washdown system with stainless steel fitting*
- Rubrail, [white] high impact vinyl retainer with steel insert*
- Seat, stainless frame, 5-position backrest, cooler storage*
- Tackle center, (4) drawer
- Trolling motor wiring kit (plug & 10" light)

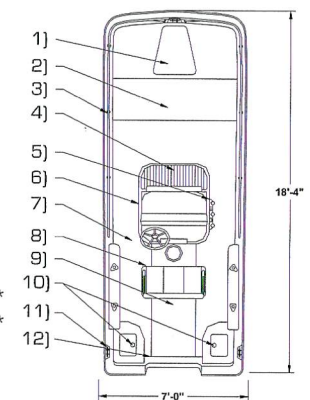

- 1) INTEGRATED ANCHOR LOCKER
- 2) 260 QT. INSULATED FISH / STORAGE BOX
- 3) STAINLESS STEEL WRAP AROUND BOW RAILS
- 4) 44 QT. STORAGE BOX
- 5) VERTICAL ROD RACK
- 6) LOCKABLE CONSOLE STORAGE
- 7) 74 SQ. FT. COCKPIT AREA
- 8) 52 QT. SWING BACK COOLER SEAT
- 9) 35 GAL. BELOW DECK FUEL TANK
- 10) 44 QT. AERATED LIVEWELL
- 11) (3) STAINLESS STEEL 6" CLEATS
- 12) SELF-BAILING DECK

*SX Sport Package Upgrade replaces similar item on standard model.

Mckee Craft
www.mckeecraft.com THE UNSINKABLES

185 Light Tackle CC

SPECIFICATIONS

Overall Length	18'-4"
Beam	7' 0"
Draft	11"
Approx. Boat Weight	1560 lbs
Maxi. Weight Capacity	1640 lbs
Swamped Capacity	2850 lbs
Persons Capacity	8
Maximum Power	150 hp
Recommended Power	90hp
Minimum Power	70 hp
Transom Height	20"
Fuel Capacity	35 gal
Interior Freeboard	19"



STANDARD FEATURES

Hull and Deck

- 100% Unsinkable - PBS™ pressure foam filled construction
- 10-year limited structural hull warranty
- Bow/lifting eye, stainless steel
- Cleat, bow, 6" recessed (2) stainless steel
- Cleats, stern, 6" recessed (2) stainless steel
- Fiberglass deck with patterned anti-skid surface
- Meets or exceeds all applicable U.S. Coast Guard safety standards
- Rubrail, heavy duty vinyl reinforced, Uni-flex
- Stable cathedral hull design
- Storage, all boxes completely insulated and drain directly overboard
- Transom lifting eyes, (2) stainless steel

Fishability

- Livewells, (2) oval 44 qt
- Livewell pump, 950 GPH
- Forward casting deck, 29 sq ft, snag-free
- Raw water washdown system
- Rod holders, (4) flushmount, stainless steel
- Rod storage rack, (3) vertical

Storage

- Anchor locker
- Console seat storage, 44 qt
- Dry console storage area, lockable
- Fishbox, insulated full-beam, 260 qt

Mechanical

- Battery box, in console
- Fuel tank, welded aluminum, 35 gal
- Navigation lights
- Steering, Uflex Rotech® Planetary Gear design
- Trim tabs, Lenco
- Wiring system, modular, expandable

Console Features

- Console, ergonomic space saving design with lockable storage
- Console seat with forward cushioned storage
- Rail, console, stainless steel
- Steering wheel, ultra-grip five spoke stainless steel
- Windshield, Plexiglas

Cockpit

- Cambered floor for rapid self-bailing
- Cockpit drains with flapper valve stainless steel
- Seat, swingback with 52 qt cooler
- Twist latches on all boxes, stainless steel

"McKee Craft's construction gives you confidence and peace of mind... You've got to love a boat that simply cannot sink..."

Boating Magazine



OPTIONS

- Bilge pump, 550 GPH with automatic float switch
- Bimini top, Sunbrella® w/ stainless steel hardware & fasteners
- Colored hull sides, (7) selections
- Compass, 3" flushmount, illuminated
- Cushion, bow, foldable to access fishbox
- Cushion, gunnel bolsters
- Cushion, livewell with backrest
- Fiberglass, gunnel board upgrade
- Fiberglass, platform with boarding ladder
- Fuse block, ATO style
- Leaning post
- Rails, bow, stainless steel wraparound
- Rails, side, stainless steel 2' x 4"
- Rails, side, stainless steel 4' x 4"
- Rails, side, stainless steel 6' x 6"
- Rails, side, stainless steel 9' x 6"
- Rails, side, stainless steel 11' x 6"
- Rails, stern, stainless steel, SX style
- Rod storage rack, (3) vertical (portside)
- Seats, Captain's chairs (2) upgrade
- Seats, Tempress® bow fishing chair, removable
- Steering upgrade, tilt hydraulic
- Tackle center (4) drawer
- Trolling motor wiring kit (plug & 10" light)
- T-top

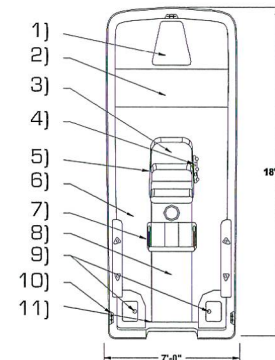

- 1) INTEGRATED ANCHOR LOCKER
- 2) 260 QT. INSULATED FISH / STORAGE BOX
- 3) 44 QT. STORAGE BOX
- 4) VERTICAL ROD RACK
- 5) SPACE SAVING CONSOLE
- 6) 74 SQ. FT. COCKPIT AREA
- 7) 52 QT. SWING BACK COOLER SEAT
- 8) 35 GAL. BELOW DECK FUEL TANK
- 9) 44 QT. AERATED LIVEWELL
- 10) (3) STAINLESS STEEL 6" CLEATS
- 11) SELF-BAILING DECK

ANCHOR BOX

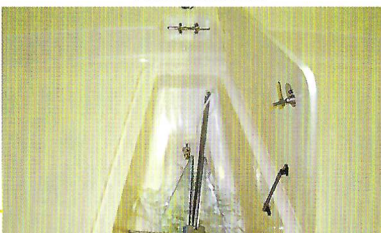

LARGE BOW DECK

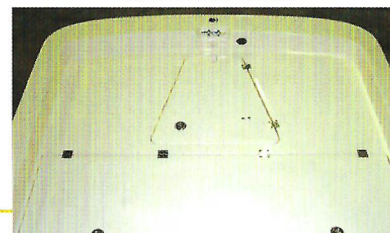

CONSOLE ACCESS DOOR

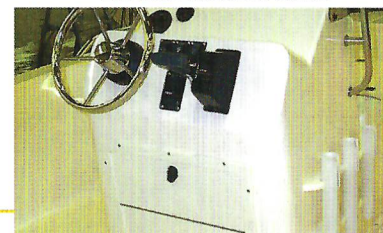

McKee Craft
www.mckeecraft.com THE UNSINKABLES

172 Backwater CC

SPECIFICATIONS

Overall Length	17'-2"
Beam	7'-0"
Draft	11"
Approx. Boat Weight	1250 lbs
Max. Weight Capacity	1260 lbs
Swamped Capacity	2650 lbs
Persons Capacity	5
Maximum Power	115 hp
Recommended Power	90 hp
Minimum Power	60 hp
Transom Height	20"
Fuel Capacity	36 gal
Deadrise at Transom	18°
Interior Freeboard	19"



SHOWN WITH SX SPORT PACKAGE

STANDARD FEATURES

Hull and Deck

- 100% Unsinkable - PBS™ pressure foam filled construction
- 10-year limited structural hull warranty
- Bow eye, stainless steel
- Cleat, bow, 6" stainless steel
- Cleats, stern, 6" (2) stainless steel
- Fast/dry - reverse lifting strake hull design
- Fiberglass deck with patterned anti-skid surface
- Meets or exceeds all applicable U.S. Coast Guard safety standards
- Rubrail heavy duty vinyl, reinforced, Uni-flex
- Shallow draft tunnel hull design
- Storage, all boxes completely insulated and drain directly overboard
- Transom lifting eyes, (2) stainless steel

Fishability

- Forward casting deck, snag-free
- Livewells, (2) oval 48 qt
- Livewell pump, 950 GPH
- Raw water washdown system
- Rod storage rack, (3) vertical

Storage

- Anchor locker
- Dry console storage area, lockable
- Fishbox, insulated full-beam, 144 qt
- Storage under console seat, 44 qt

Mechanical

- Battery box, in console
- Fuel tank, welded aluminum, 36 gal
- Navigation lights
- Steering, Uflex Rotech® Planetary Gear design
- Wiring system, modular, expandable

Console Features

- Console, ergonomic, space saving design with lockable storage
- Seat, forward of console w/cushion & 44 qt storage
- Console storage with large access door, lockable
- Rail, console, stainless steel
- Steering wheel, ultra-grip five spoke, stainless steel
- Windshield, Plexiglas

Cockpit

- Cambered floor for rapid self-bailing
- Cockpit drains with flapper valve, stainless steel
- Rails, bow, curved stainless steel 4' x 4"
- Seat, swingback with cooler, 52 qt

"Having owned Whalers and Mako's in the past I know what it takes to be a great boat... My McKee is tougher and requires less maintenance than any of them..."
Dick Shepard, Michigan



172 BACKWATER OPTIONS

- Bilge pump, 550 GPH with automatic float switch
- Bimini top, Sunbrella® w/stainless steel hardware & fasteners
- Bow/lifting eye, stainless steel
- Colored hull sides (7) selections
- Compass, 3" flushmount, illuminated
- Cushion, bow
- Cushion, livewell with backrest
- Fiberglass, gunnel board w/4 stainless steel rod holders
- Fuse block, ATO style
- Platform, boarding w/two step ladder and handrail
- Rails, side, stainless steel 2' x 4"
- Rails, side, stainless steel 4' x 4"
- Rails, side, stainless steel 6' x 6"
- Rails, bow, stainless steel, SX style 8' x 6"
- Rails, bow, stainless steel, wraparound
- Rod holder, surface mount swivel, stainless steel
- Rod storage rack, (3) vertical
- Seat, Captain's chairs (2) upgrade
- Seat, Tempress® bow fishing chair, removable
- Steering upgrade, tilt hydraulic
- Tackle center (4) drawer
- Trolling motor wiring kit (plug & 10" light)

SX SPORT PACKAGE FEATURES INCLUDE:

- Beverage holder, (2)
- Bilge pump, 550 GPH with automatic float switch
- Carbon fiber look dash panel
- Cockpit courtesy lights, LED*
- Colored hull sides (7) selections are standard
- Cushion, livewell with backrest
- Deluxe backlit multifunction switch panel and wiring system*
- Fiberglass, gunnel boards with bolsters
- Fuse block, ATO style
- Rubrail, [white] high impact vinyl retainer w/stainless steel insert*
- Glovebox, lockable
- Pneumatic hatch lifts assists on bow fishbox, stainless steel
- Rails, bow, stainless steel, SX style 8' x 6"*
- Rails, corner stern, stainless steel
- Raw water washdown system with stainless steel fitting*
- Rod holders, (4) flushmount, stainless steel
- Seat, stainless frame, 5-position backrest, 72 qt cooler*
- Tackle center, 4 drawer
- Trolling motor wiring kit (plug & 10" light)
- Twist latches on all boxes, stainless steel*

*SX Sport Package upgrade replaces similar feature on standard model.

POWERED BY:
EVINRUDE

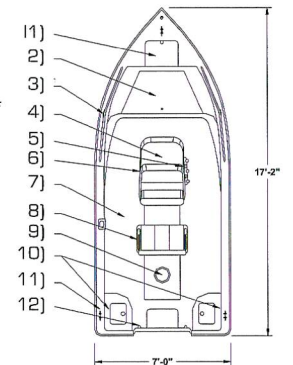

- 1) INTEGRATED ANCHOR LOCKER
- 2) 144 QT. INSULATED FISH / STORAGE BOX
- 3) STAINLESS STEEL BOW RAILS
- 4) 44 QT. STORAGE BOX
- 5) VERTICAL ROD RACK
- 6) SPACE SAVING CONSOLE
- 7) 62 SQ. FT. COCKPIT AREA
- 8) 52 QT. SWING BACK COOLER SEAT
- 9) 36 GAL. BELOW DECK FUEL TANK
- 10) 48 QT. AERATED LIVEWELL
- 11) (3) STAINLESS STEEL 6" CLEATS
- 12) SELF-BAILING DECK

ANCHOR BOX



CONSOLE ROD HOLDERS

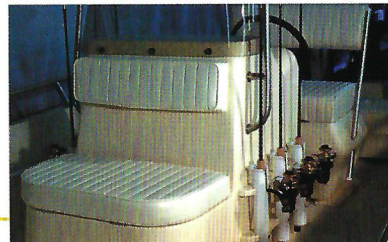

144 QT FISHBOX

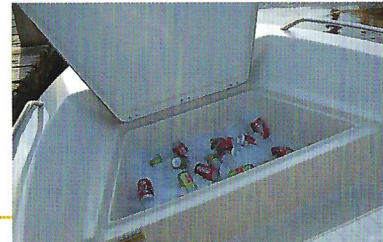

McKee Craft
www.mckeecraft.com THE UNSINKABLES

172 Backwater DC

SPECIFICATIONS

Overall Length	17'-2"
Beam	7'-0"
Draft	11"
Approx. Boat Weight	1250 lbs
Max. Weight Capacity	1260 lbs
Swamped Capacity	2650 lbs
Persons Capacity	5
Maximum Power	115 hp
Recommended Power	90 hp
Minimum Power	60 hp
Transom Height	20"
Fuel Capacity	36 gal
Deadrise at Transom	18°
Interior Freeboard	19"



STANDARD FEATURES

Hull and Deck

- 100% Unsinkable - PBST[™] pressure foam filled construction
- 10-year limited structural hull warranty
- Bow eye, stainless steel
- Cleat, bow, 6" stainless steel
- Cleats, stern, 6" (2) stainless steel
- Dual console design with wraparound windshield
- Fast/dry - reverse lifting strake hull design
- Fiberglass deck with patterned anti-skid surface
- Meets or exceeds all applicable U.S. Coast Guard safety standards
- Rubrail heavy duty vinyl, reinforced, Uni-flex
- Shallow draft tunnel hull design
- Storage, all boxes completely insulated and drain directly overboard
- Transom lifting eyes, (2) stainless steel

Fishability

- Cockpit, large aft floor area for maximum fishability
- Forward casting deck, snag-free
- Livewells, (2) oval 48 qt
- Livewell pump, 950 GPH
- Raw water washdown system

Mechanical

- Battery storage area
- Fuel tank, welded aluminum, 36 gal
- Navigation lights
- Wiring system, modular, expandable

Console Features

- Consoles designed for maximum weather protection
- Console grabrail, stainless steel, passenger side
- Console storage areas (2) with large access door, lockable
- Glovebox, lockable
- Steering wheel, ultra-grip five spoke, stainless steel
- Windshield, walk-through tempered glass w/ aluminum frame

Cockpit

- Cambered floor for rapid self-bailing
- Cockpit drains with flapper valve, stainless steel
- Rails, bow, curved stainless steel 4' x 4"
- Seat, Captain's chairs (2) w/ slides and cushions
- Sunbrella[®] center flap wind block

"As a charter captain and SKA divisional winner, I have fished just about every boat out there. McKee Craft is a great company that builds an unbeatably rugged and well constructed boat, solidly built for the serious offshore angler who demands reliability, quality and performance. There is an abundance of standard features that are designed and built for functionality and ease of use..."

Chris Machacek,

Charter Captain and SKA Divisional Champion

Storage

- Anchor locker
- Dry storage area under both consoles, lockable
- Fishbox, insulated full-beam, 144 qt

OPTIONS

- Bilge pump, 550 GPH with automatic float switch
- Bow/lifting, eye, stainless steel
- Colored hull sides (7) selections
- Compass, 3" flushmount, illuminated
- Cushion, bow (5 pc)
- Cushion, livewell with backrest
- Deluxe top, Sunbrella[®] w/ stainless steel hardware & fasteners
- Fiberglass, boarding platform w/ two step ladder and handrail
- Fuse block, AT0 style
- Rails, side, stainless steel 2' x 4"
- Rails, side, stainless steel 4' x 4"
- Rails, side, stainless steel 6' x 6"
- Rails, stern, stainless steel, SX style
- Rails, bow, stainless steel, wraparound
- Rod holder, surface mount swivel, stainless steel
- Seat, Tempress[®] bow fishing chair, removable
- Seats, lounge seat upgrade (portside exchange)
- Side curtains, for deluxe top
- Steering upgrade, tilt hydraulic
- Trolling motor wiring kit (plug & 10" light)

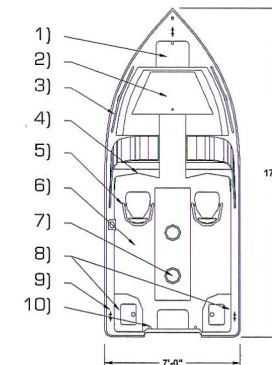

- 1) INTEGRATED ANCHOR LOCKER
- 2) 144 QT. INSULATED FISH / STORAGE BOX
- 3) STAINLESS STEEL BOW RAILS
- 4) DUAL LOCKABLE CONSOLES
- 5) DELUXE PILOT CHAIRS
- 6) 62 SQ. FT. COCKPIT AREA
- 7) 36 GAL. BELOW DECK FUEL TANK
- 8) 48 QT. AERATED LIVEWELL
- 9) (3) STAINLESS STEEL 6" CLEATS
- 10) SELF-BAILING DECK

LOUNGE SEAT



STARBOARD CONSOLE



DUAL 48 QT OVAL LIVEWELLS



McKee Craft
www.mckeecraft.com THE UNSINKABLES

17 Waypoint

SPECIFICATIONS

Overall Length	17'-4"
Beam	7'-2"
Draft	10"
Approx. Boat Weight	1480 lbs
Max. Weight Capacity	1770 lbs
Swamped Capacity	3300 lbs
Persons Capacity	8
Maximum Power	160 hp
Recommended Power	90 hp
Minimum Power	60 hp
Transom Height	20"
Fuel Capacity	18 gal
Interior Freeboard	19"



STANDARD FEATURES

Hull and Deck

- 100% Unsinkable - PBT™ pressure foam filled construction
- 10-year limited structural hull warranty
- Bow/lifting eye, stainless steel
- Cleat, bow, 6" stainless steel
- Cleats, stern, 6" (2) stainless steel
- Fiberglass deck with patterned anti-skid surface
- Meets or exceeds all applicable U.S. Coast Guard safety standards
- Rubrail, heavy duty vinyl, reinforced, Uni-flex
- Stable cathedral hull design
- Transom lifting eyes, (2) stainless steel

Fishability

- Livewell, oval 44 qt
- Livewell pump, 550 GPH

Storage

- Optional forward storage box
- Fishbox insulated, (2) 48 qts each (16 only)

Mechanical

- Fuel gauge, direct read, tank mounted
- Fuel tank, welded aluminum, 18 gal
- Navigation lights
- Steering, Uflex Rotech® Planetary Gear design
- Wiring system, modular, expandable

Console Features

- Console, center mounted, rounded corner design
- Console grab rail, stainless steel
- Console seat with forward cushion
- Windshield, Plexiglas

Cockpit

- Seat, swingback with 52 qt cooler

SPECIFICATIONS

Overall Length	16"
Beam	6'-7"
Draft	9"
Approx. Boat Weight	990 lbs
Max. Weight Capacity	1370 lbs
Swamped Capacity	2650 lbs
Persons Capacity	6
Maximum Power	115 hp
Recommended Power	70 hp
Minimum Power	40 hp
Transom Height	20"
Fuel Capacity	18 gal
Interior Freeboard	18"



OPTIONS

- Bilge pump, 550 GPH with automatic float switch
- Bimini top, Sunbrella® with stainless steel hardware & fasteners
- Colored hull sides (7) selections
- Compass, 3" flushmount, illuminated
- Cushion, bow set
- Cushion, forward storage box
- Cushion, rear bench seat
- Fiberglass, forward storage box
- Fiberglass, platform with boarding ladder
- Fiberglass, rear bench seat/livewell
- Fishboxes (2) insulated, 48 qts each (17 only)
- Fuse block, ATO style
- Rails, bow, wraparound, stainless steel
- Rails, side, stainless steel 2' x 4"
- Rails, side, stainless steel 4' x 4"
- Rails, side, stainless steel 6' x 6"
- Rails, side, stainless steel 9' x 6"
- Rails, side, stainless steel 11' x 5"
- Rod holder, surface mount swivel, stainless steel
- Rod storage rack, (3) vertical
- Seat, Tempress® bow fishing chair, removable
- Steering upgrade, tilt hydraulic
- Trolling motor wiring kit (plug & 10" light)

17 WAYPOINT

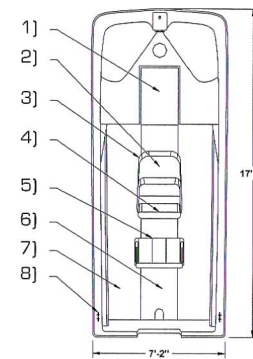

- 1) OPT. FORWARD STORAGE BOX
- 2) 44 QT. AERATED LIVEWELL
- 3) SPACE-SAVING CONSOLE
- 4) 18 GAL. REMOVABLE FUEL TANK
- 5) 52 QT. SWING BACK COOLER SEAT
- 6) RIGGING TUNNEL
- 7) 67 SQ. FT. COCKPIT AREA
- 8) (3) STAINLESS STEEL 6" CLEATS

16 WAYPOINT

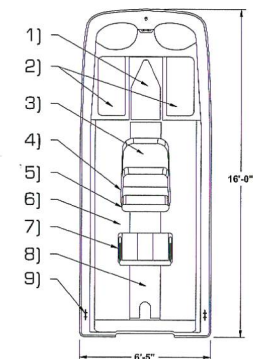

- 1) OPT. FORWARD STORAGE BOX
- 2) DUAL 48 QT. STORAGE / FISH BOXES
- 3) 44 QT. AERATED LIVEWELL
- 4) SPACE SAVING CONSOLE
- 5) 18 GAL. REMOVABLE FUEL TANK
- 6) 45 SQ. FT. COCKPIT AREA
- 7) 52 QT. SWING BACK COOLER SEAT
- 8) RIGGING TUNNEL
- 9) (3) STAINLESS STEEL 6" CLEATS

"You've got to love a boat that simply cannot sink..."

Boating Magazine

WAYPOINT CONSOLE



EXTRA LARGE COCKPIT



OPTIONAL BIMINI TOP



McKee Craft
www.mckeecraft.com THE UNSINKABLES

14 Cat Cay

SPECIFICATIONS

Overall Length	14'
Beam	5'-7"
Draft	7"
Approx. Boat Weight	665 lbs
Max. Weight Capacity	890 lbs
Swamped Capacity	1750 lbs
Persons Capacity	4
Maximum Power	65 hp
Recommended Power	50 hp
Minimum Power	25 hp
Transom Height	20"
Fuel Capacity	Portable
Interior Freeboard	15"



STANDARD FEATURES

Hull and Deck

- 100% Unsinkable - PBS™ pressure foam filled construction
- 10-year limited structural hull warranty
- Bow/lifting eye, stainless steel
- Cleat, bow, 6" stainless steel
- Cleats, stern, 6" (2) stainless steel
- Fiberglass deck with patterned anti-skid surface
- Meets or exceeds all applicable U.S. Coast Guard safety standards
- Rubrail, heavy duty vinyl, reinforced, Uni-flex
- Stable cathedral hull design
- Transom lifting eyes, (2) stainless steel

Storage

- Bow ice box, 88 qt

Console features

- Console, fiberglass, space saving design (rear side mounted)
- Console top, flat for electronics mounting
- Steering wheel, ultra-grip five spoke stainless steel

Cockpit

- Fiberglass bench seat (rear mounted)

Mechanical

- Fuel tanks, storage area for (2) removable 6 gal
- Navigation lights
- Steering, Uflex Rotech® Planetary Gear design
- Wiring system, modular, expandable

OPTIONS

- Bench seat, fiberglass
- Bench seat cushion, rear
- Bench seat storage box
- Bilge pump, 550 GPH with automatic float switch
- Bimini top, Sunbrella® with stainless steel hardware & fasteners
- Colored hull sides (7) selections
- Compass, 3" flushmount, illuminated
- Fuse block, ATO style
- Rod holders, surface mount swivel, stainless steel
- Seat, Tempress® bow fishing chair, removable
- Rails, bow, wraparound, stainless steel
- Rails, side, stainless steel 2' x 4"
- Rails, side, stainless steel 4' x 4"
- Rails, side, stainless steel 6' x 6"
- Trolling motor wiring kit (plug and 10" light)

SPECIFICATIONS

Overall Length	14'
Beam	5'-7"
Draft	7"
Approx. Boat Weight	665 lbs
Max. Weight Capacity	890 lbs
Swamped Capacity	1750 lbs
Persons Capacity	4
Maximum Power	65 hp
Recommended Power	50 hp
Minimum Power	25 hp
Transom Height	20"
Fuel Capacity	Portable
Interior Freeboard	15"

14 Waypoint



CAT CAY SX SPORT PACKAGE FEATURES INCLUDE:

- Bench seat cushion
- Bench seat, fiberglass (rear mount)
- Bench seat storage box
- Bilge pump, 550 GPH with automatic float switch
- Bow rail, stainless steel wraparound
- Colored hull sides (7) selections are standard
- Console, full fiberglass, mounted forward*
- Deluxe swivel folding chairs (2)
- Rubrail, (white) high impact vinyl retainer & stainless steel insert*
- Side rails, stainless steel, 6' x 6"
- Trolling motor wiring kit (plug & 10" light)

* SX Sport Package upgrade replaces similar feature on standard model.

"I've owned boats all my life...the McKee 14' is more boat for the money than any of them."

Todd Payne, New Hampshire



POWERED BY:
EVINRUDE

14 CAT CAY SX

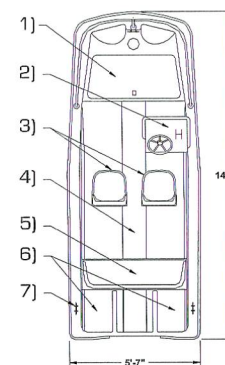

- 1) 88 QT. STORAGE LOCKER
- 2) FIBERGLASS SIDE CONSOLE
- 3) FOLDING FISHING CHAIRS
- 4) RIGGING TUNNEL
- 5) REAR BENCH SEAT WITH DRY STORAGE
- 6) 6 GAL. FUEL TANK STORAGE
- 7) (3) STAINLESS STEEL 6" CLEATS

14 WAYPOINT

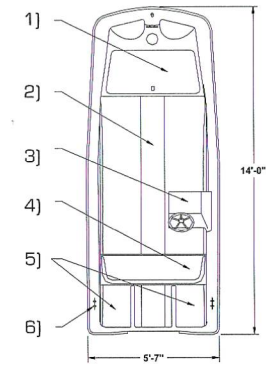

- 1) 88 QT. STORAGE BOX
- 2) RIGGING TUNNEL
- 3) SOLID FIBERGLASS SIDE CONSOLE
- 4) REAR BENCH SEAT
- 5) 6 GAL. FUEL TANK STORAGE
- 6) (3) STAINLESS STEEL 6" CLEATS

14 WAYPOINT CONSOLE



88 QT COOLER

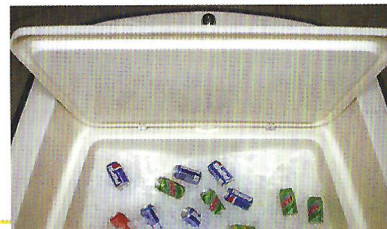

BENCH SEAT/STORAGE



McKee Craft
www.mckeecraft.com THE UNSINKABLES

24 Freedom CC

Designed for serious offshore and inshore fishing with single or dual outboards, the McKee Craft 24 Freedom is styled after our popular 28 Freedom, but has a personality all its own. Like all McKee Crafts, the boat is unsinkable and constructed of 100% composite materials. Every inch of the hull and deck are bonded together with our exclusive PBS™, Pressure Bonding System. This system creates one unitized part that is far more rigid and stronger than traditionally constructed boats. Fishing features and amenities abound with a wide array of items such as factory installed T-top with outriggers, freshwater washdown system, huge storage compartments, dual livewell pumps, tilt hydraulic steering and much more.

SPECIFICATIONS

Overall Length	24'
Beam	8'-6"
Approx. Boat Weight	TBA
Persons Capacity	10
Maximum Power	400 hp
Transom Height	25"/30"
Fuel Capacity	185 gal
Deadrise at Transom	24.5°
Interior Freeboard	25"

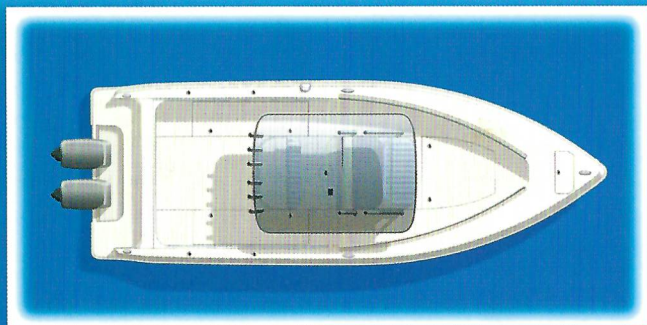

Available Spring 2003

Featured Options

SS 2' X 4" SIDE RAILS

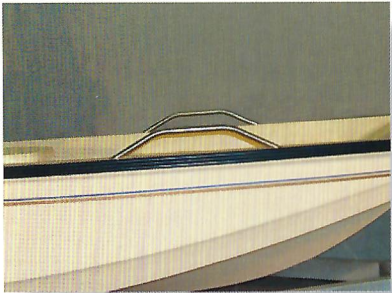

SS 4' X 4" SIDE RAILS



SS 6' X 6" SIDE RAILS

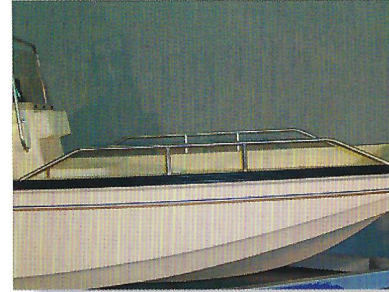

SS WRAPAROUND BOW RAIL



BOARDING ASSIST KIT



OPT. LEANING POST SEAT



BOW FISHING CHAIR



TROLLING WIRING UPGRADE

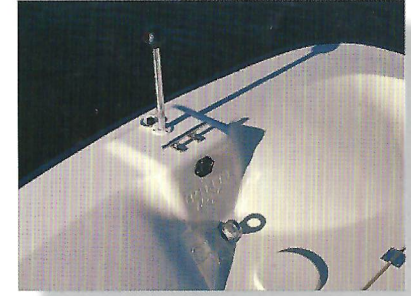

SWIVEL SS ROD HOLDER



BACKWATER LIVEWELL CUSHION



DELUXE TOP



LOUNGE SEAT UPGRADE





McKee Craft
THE UNSINKABLES

P.O. BOX 623
FAIRMONT, NC 28340
910.628.0926 FAX 910.628.9598
www.mckeecraft.com

Printed in U.S.A

Part # BRO 10,001 \$3.50 EACH

McKee Craft strives to offer the best quality & safest boats on the water. As a result, McKee Craft reserves the right to make changes in specifications, options, standard features, color schemes and discontinue models at any time without notice or obligation. Please contact your local dealer or the factory for additional information.