



McKee Craft[™]
The Unsinkables

McKee Craft

When you purchase a McKee Craft, you don't just buy a boat, you buy a company. We believe unsurpassed safety and reliability must be the backbone of every boating experience. Our passion for boats and the families who own them is reflected in the way every McKee Craft stands up to the toughest conditions and is unsinkable.

History

In 1966, after extensive testing and trials, Lanness McKee discovered the secrets of unsinkable marine construction by pressure foam filling. The process of foam fusing every square inch of the deck and hull enables us to build a boat without stringers and spars. This one piece design offers virtually no flex, is quiet in the water and exceeds the strength of any boat built with conventional wood or fiberglass stringer systems. Don't take our word for it, just ask any one of our over 30,000 McKee Craft owners. Or better yet, listen to the experts. Over 1,500 McKee Craft boats are currently in service with local, state and federal agencies who are protecting our waters.

Quality

McKee Craft products reflect the commitment to our customers and their families. Only time-tested quality materials are used. Hulls are strengthened at key points with syntactic core and the decks are strengthened with a poly/ceramic core, which has the strength of solid oak. Every hull comes with a 10-year limited transferable warranty. These are just a few of the reasons why McKee Craft boats maintain a high resale value—and many are passed down from generation to generation.

The Smart Choice

McKee Craft has earned a reputation for being the smart choice for avid boating families who love to fish. Why? Because our boats are practical, durable and easy to maintain. We have put over four decades of fishing experience into each McKee Craft, so you can count on having a generous list of standard equipment and the features you need.

We invite you to visit your local dealer for a sea trial, or contact us directly for more information. Call us today at 910-628-0926, or visit us at www.mckeecraft.com.

Go Fish!

The McKee Craft Team





McKee Craft, Inc
P.O. Box 623
Fairmont, NC 28340

Dear Sir:

How tough is a 14' McKee boat supposed to be?

With a crushed bow and shattered side, rub rails pulled loose to act as a second sea anchor, five men aboard –water, gas & supplies; is it supposed to withstand the hammering if 30' waves in a full gale for 37 hours and not disintegrate? Well, we thank God you build a boat with that hidden bonus of integrity that keep it intact in spite of the above abuse and misuse.

When my 47' motor sailer, the Tiki, foundered after 2 days in a full gale beating off the Grand Bahama Shoals, we took to the life boat. After we sent out our Mayday, we spent 2 hours putting gear aboard and where possible tying it down...

To stow these things, one man was aboard with two men pulling the McKee up to the stern and two men above slinging gear aboard. Time and again the stern rub rail of the ketch crashed down on the bow of the McKee—all 20 tons—splintering the bow and stern no matter how we tried to fend it off. The waves were 30 feet or higher, the wind at 60 on my anemometer – it was a wild sea. One side swipe splintered the right side of the bow sheering off a piece 10 inches by 2 feet from the outside fiberglass covering, exposing the flotation material...

As the U.S. Coast Guard said to my sons 24 hours after the Tiki sank, "there is no use our continuing this search; no small boat could possibly survive in the cross seas in a Gulf Stream gale of this magnitude." Little did they know of your great design, how well she responded to a quick turn of motor to avoid a cresting, crashing wave and how her structure could hold together under the incessant pounding of tremendous, solid seas.

We eventually ran out of gas...having traveled right through the teeth of the gale. Five hours later, 10 miles further out, and some 20 miles further north, we were picked up by the SS Texaco Nebraska and...taken aboard, two by stretcher, one unconscious and three of us still on our feet.

All of us are grateful I picked a McKee boat as a tender and life boat we're further grateful you people really know how to build a boat with that extra integrity that made it so much more durable than we could reasonably expect.

Sincerely yours

S.M. "Bus" Huestis

Captain & owner of the late Tiki and survivor
By the Grace of God, The SS Texaco Nebraska
and the Builders of the McKee Craft.



One tough, superbly built, . . .

FLOTATION

Most 18' boats require only 80 lbs of foam to meet U.S. Coast Guard requirements for level flotation and 125 pounds to fill the hull... but, we pack it in, under pressure using 200 lbs. That is more than two and a half times the requirement set by the U.S. Coast Guard. The foamed boat is also allowed to cure overnight in the mold. During our in-mold construction cycle, some competitor's molds have already built as many as 2 boats during the same period of time. That's why our dimensional stability is like no other boat on the market.

100% UNSINKABLE CONSTRUCTION

Safety is the reason why each and every McKee Craft boat features our unsinkable construction. McKee Craft takes that requirement to the next level: our boats will not only float, but also remain upright in calm water, even if the boat is cut in half.

UNMATCHED DURABILITY

McKee Craft boats do not have stringers. We utilize a totally unique construction method we call "PBS," our Pressure Bonding System. This unique method of construction allows the strength of the deck to combine with the strength of the hull, both complimenting each other, resulting in the most rugged hulls in the industry.

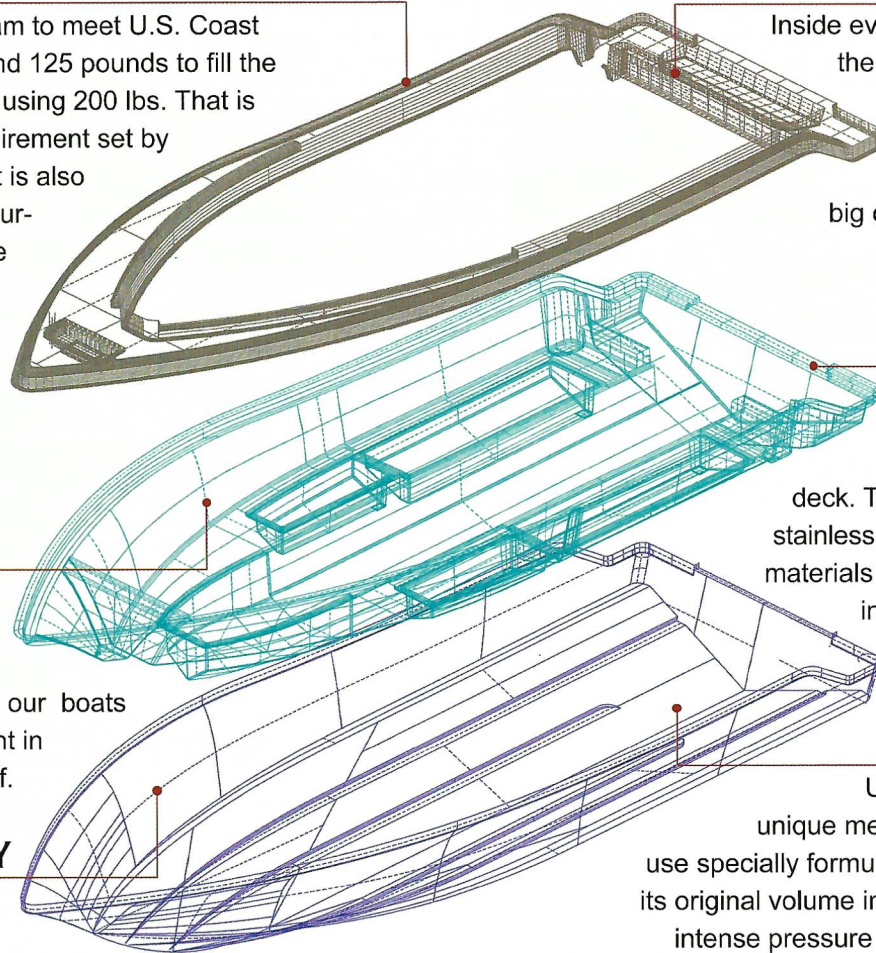

BEAUTY IS MORE THAN SKIN DEEP

Inside every McKee Craft is a story that you can't see. It is the passion that drives our team to design, engineer, and manufacture to the highest standards... the heart that understands the importance of family time, memories of time on the water, the first big catch... and the peace of mind knowing that your boat is safe and unsinkable.

HULL & DECK BOND

The hull and deck are permanently bonded with ATC B39 bonding putty, which ensures a complete, rather than spot bond of the hull and deck. To properly secure factory installed equipment, 316 stainless steel screws and high strength composite backing materials such as 1/2" thick polyethylene or aluminum plating are utilized throughout McKee Craft's construction systems.

THE "PBS" SYSTEM

Unlike other manufacturers, McKee Craft utilizes a unique method of injecting flotation foam into our boats. We use specially formulated polyurethane foam that expands to 50 times its original volume in less than a minute. The combination of heat and intense pressure chemically and mechanically bonds every square inch of the hull to every inch of the deck. The two pieces become one integral part. This added rigidity reduces hull noise, eliminates stress cracking and minimizes hull flex in rough seas.

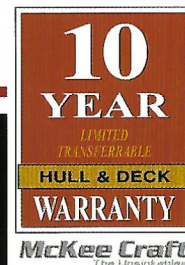

.unsinkable fish boat.

Typical Boat Construction

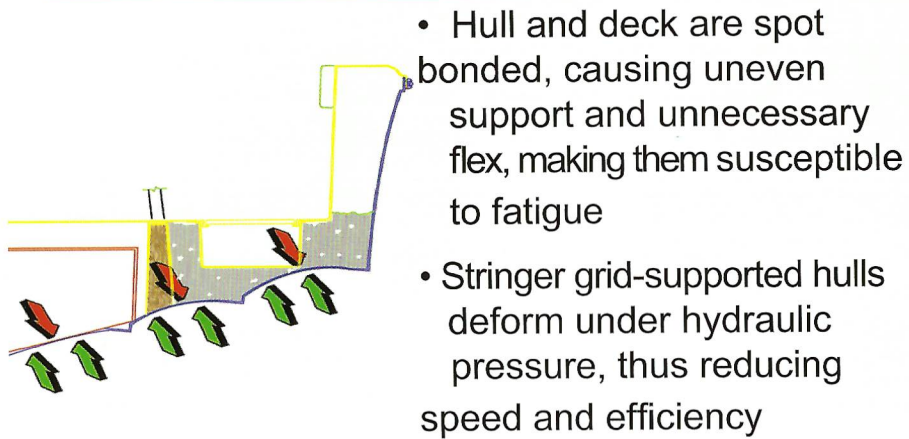

- Hull and deck are spot bonded, causing uneven support and unnecessary flex, making them susceptible to fatigue
- Stringer grid-supported hulls deform under hydraulic pressure, thus reducing speed and efficiency
- Large open voids between the hull and liner create unnecessary hull noise
- Secondary bonded stringer grid system relies primarily on mechanical bonding for strength
- Meets Coast Guard flotation requirements

The McKee Craft Difference

- Hull and deck liner are completely bonded, creating a unitized structure for unmatched strength

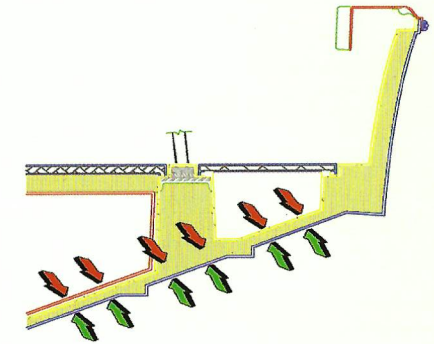

- PBS construction resists hydraulic pressure equally, thus maintaining an efficient and fast hull shape
- The foam injection system eliminates voids between outer hull and liner, resulting in a quieter ride
- McKee Craft's hull technology eliminates the need for traditional stringers and provides a mechanical and chemical bond for unsurpassed strength
- Exceeds Coast Guard requirements with up to 3 times the flotation of regular boats



McKee Craft utilizes ISO-NPG gel-coat, which has high flex properties that are resistant to cracking, and titanium dioxide pigments that are the most UV stable pigments available. This keeps the finish and colors looking beautiful for years to come.



The fiberglass ISO/DCPD ratio is precision machine metered. Highly trained lamination technicians hand-roll the fiberglass to create uniform, consistent hull thickness.

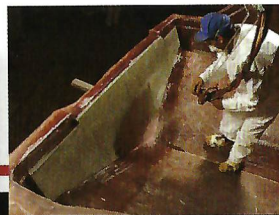

Top quality transom composites are embedded into the wet laminate on the hull. Then the composite transom is completely encapsulated in fiberglass for added strength.



Each McKee Craft hull stays in the mold for a full 48 hours to ensure a full cure for the best dimensional stability and cosmetic finish. Many manufacturers cycle molds twice a day or more which can hamper quality, distort or even twist hulls.



Fuel tanks are high quality welded aluminum with interior baffles to keep the fuel from shifting too quickly which might affect the balance of the boat. All below deck fuel tanks are foamed in place and primed with zinc chromate for greater resistance to corrosion.



Quality and craftsmanship are built-in from the start. Where you can see it, and where you can't, you can rest assure that quality is inside every inch of your McKee Craft boat.

Freedom

28 Forward Seating

28 Tournament Edition



SPECS

Overall Length **28'**
Beam **9'11"**
Draft **22"**
Approx. Boat Weight **5500 lbs**
Persons Capacity **10**

Maximum Power **600 hp**
Recommended Power **450 hp**
Minimum Power **400 hp**
Transom Height **30"**
Deadrise at Transom **24.5°**

Fuel Capacity **265 gal**
Interior Freeboard **26"**

Shown with optional equipment

Powered by:



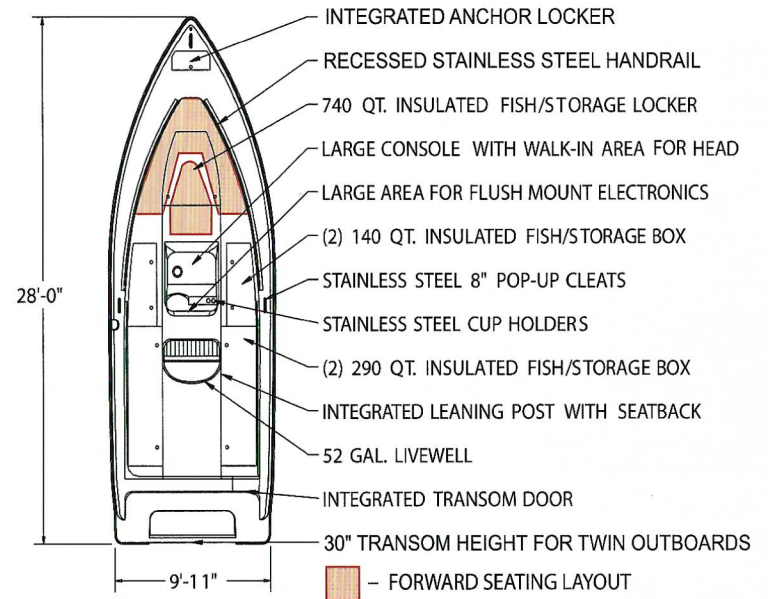

LEANING POST WITH
52 GAL LIVEWELL



ERGONOMIC DASH WITH
HYDRAULIC STEERING

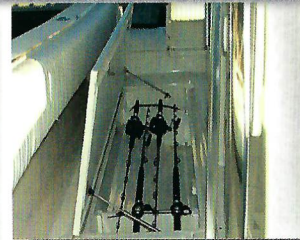

7' FISH BOX AND ROD
LOCKER

"As a charter captain and SKA divisional winner, I have fished just about every boat out there. Mckee Craft is a great company that builds an unbelievably rugged and well constructed boat, solidly built for the serious offshore angler who demands reliability, quality and performance."

Chris Machacek

Charter Captain
and SKA Divisional Champion



Safety

- 100% Unsinkable – pressure foam filled
- Molded non-skid on horizontal surfaces
- Meets or exceeds all applicable U.S. Coast Guard safety standards
- Bilge pump, 1500 gph with automatic float switch
- Bilge pump, backup, 500 gph with automatic float switch
- Deck accessible battery switch box
- Horn, flush mount stainless steel
- Navigation lights, international
- Rails, bow, elliptical recessed, stainless steel

Fishability

- Functional flush deck design
- Livewell pumps, (2) 800 GPH
- Livewell, aerated oval 52 Gal, L.E.D. lighted
- Rod holders, (4) leaning post baackrest
- Rod holders, (5) transom mount
- Rod holders, (8) removable from fishbox
- Tackle box, (2) drawer
- Tackle center, (3) drawer

Construction

- .09" aluminum backing plate system for all screw connections
- 100% all composite construction – no wood no rot
- 10-year limited transferable structural hull warranty
- Ceramic micro fiber deck coring
- PBS – "Pressure Bonding System" closed cell foam core construction
- Premium ISO / NPG high flex gel coat for strong durable finish
- Rubrail, heavy duty white vinyl, stainless steel insert
- Vinyl ester barrier coat

Console

- Head area, lockable
- Steering system, tilt hydraulic
- Steering wheel with power knob, offshore style polished stainless steel
- Wiring system, multifunction w/ breaker panel & accessory fuse block
- Engine controls factory pre-rigged

Cockpit & Deck

- 4-1/2" toe kick 360° around the cockpit
- Battery storage area
- Cambered floor for rapid self-bailing
- Cleats, bow, 8" pop-up, stainless steel

Cockpit & Deck (Cont.)

- Cockpit drains with 4 way flapper valve, stainless steel
- Cleats, spring line, (2) 8" pop-up, stainless steel
- Cleats, stern, (2) 8" pop-up, stainless steel
- Cockpit courtesy lights, LED
- Foldaway aluminum front step
- Foldaway aluminum leaning post footrest
- Fuel tank, welded aluminum, 265 gal fully accessible and serviceable
- Lifting eye, (2) stern, stainless steel
- Lifting eye, bow, stainless steel
- Leaning post with backrest and grabrail
- Manual and macerated fishbox drainage
- Molded transom door with stainless steel latch
- Pneumatic lift assist rams on all fishboxes, stainless steel
- Pop-up anchor chocks, stainless steel
- Storage, anchor locker
- Storage, bow (1) insulated, 740 qts
- Storage, (2) insulated, 140 qts each
- Storage, (2) insulated, 290 qts each
- Twist latches on all box lids, stainless steel - locking
- Saltwater, washdown
- Seating, forward with upholstery and storage (only on FS)
- Freshwater washdown

Optional equipment list on back page

Freedom

24 Forward Seating

24 Tournament Edition

23 Tournament Edition



SPECS

Overall Length	24'	Maximum Power	400 hp	Fuel Capacity	180 gal
Beam	8'6"	Recommended Power	300 hp	Interior Freeboard	27"
Draft	22"	Minimum Power	200 hp		
Approx. Boat Weight	3300 lbs	Transom Height	25" Dual/30 Single"		
Persons Capacity	10	Deadrise at Transom	24.5°		

Shown with optional equipment

Powered by:



YAMAHA



TACKLE CENTER



INSULATED FRONT STORAGE BOX



Forward Seating on the FS Model

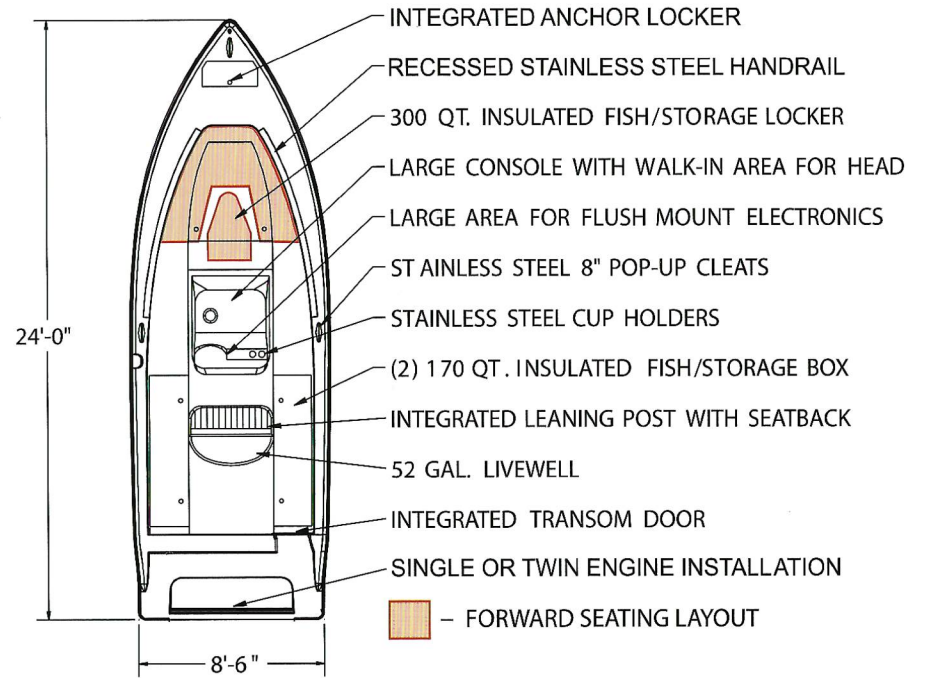

"With its roomy layout and safety features, McKee Craft's Freedom 24 is a great center console for diving or family water sports. But its ride, range and fishability also define it as an excellent fish boat."

Dave Lear, MotorBoating Magazine



Safety

- 100% Unsinkable – pressure foam filled
- Bilge pump, 1500 gph with automatic float switch
- Bilge pump, backup 500 gph with automatic float switch
- Deck accessible battery switch box
- Meets or exceeds all applicable U.S. Coast Guard safety standards
- Molded non-skid on horizontal surfaces
- Navigation lights, international
- Rails, bow, elliptical recessed, stainless steel

Fishability

- Functional flush deck design
- Livewell pumps, (2) 800 gph
- Livewell, aerated oval 52 Gal, LED lighted
- Rod holders, (4) leaning post backrest
- Rod holders, (5) transom mount
- Tackle box, (2) drawer
- Tackle center, (3) drawer

Console

- Engine controls factory pre-rigged
- Head area, lockable
- Steering system, tilt hydraulic

Console (cont.)

- Steering wheel with power knob, offshore style polished stainless steel
- Windshield, Plexiglas
- Wiring system, multifunction w/ breaker panel & accessory fuse block

Construction

- .09" aluminum backing plate system for all screw connections
- 100% all composite construction – no wood no rot
- 10-year limited transferable structural hull warranty
- Ceramic micro fiber deck coring
- PBS – "Pressure Bonding System" closed cell foam core construction
- Premium ISO / NPG high flex gel coat for strong durable finish
- Rubrail, heavy duty white vinyl, stainless steel insert
- Vinyl ester barrier coat

Cockpit & Deck

- 3½" toe kick 360° around the cockpit
- Battery storage area
- Cambered floor for rapid self-bailing
- Cleat, bow, 8" pop-up, stainless steel
- Cleat, spring line, (2) 8" pop-up, stainless steel
- Wrap around cockpit bolsters (optional on TE)
- Cleat, stern, (2) 8" pop-up, stainless steel

Cockpit & Deck (cont.)

- Cockpit drains with 4 way flapper valve, stainless steel
- Foldaway aluminum front step
- Foldaway aluminum leaning post footrest
- Fuel tank, welded aluminum, 180 gal fully accessible and serviceable
- Leaning post with backrest and grabrail
- Lifting eye, (2) stern, stainless steel
- Lifting eye, bow, stainless steel
- Lighting, cockpit courtesy lights LED
- Macerated fishbox drainage
- Molded transom door with stainless steel latch
- Pneumatic lift assist rams on all fish boxes, stainless steel
- Pop-up anchor chocks, stainless steel
- Storage, (2) insulated, 170 qts each
- Storage, anchor locker
- Storage, bow (1) insulated, 300 qts
- Trim tabs, Lenco® sport tabs with position indicators
- Twist latches on all box lids, stainless steel
- Saltwater washdown
- Fresh water washdown
- Seating, forward with upholstery and storage (only on FS)

Optional equipment list on back page

Freedom

24 Express



SPECS

Overall Length	24'	Maximum Power	400 hp	Fuel Capacity	146 gal
Beam	8'6"	Recommended Power	300 hp	Interior Freeboard	27"
Draft	22"	Minimum Power	200 hp		
Approx. Boat Weight	3300 lbs	Transom Height	25" Dual/30" Single		
Persons Capacity	10	Deadrise at Transom	24.5°		

Shown with optional equipment

Powered by:



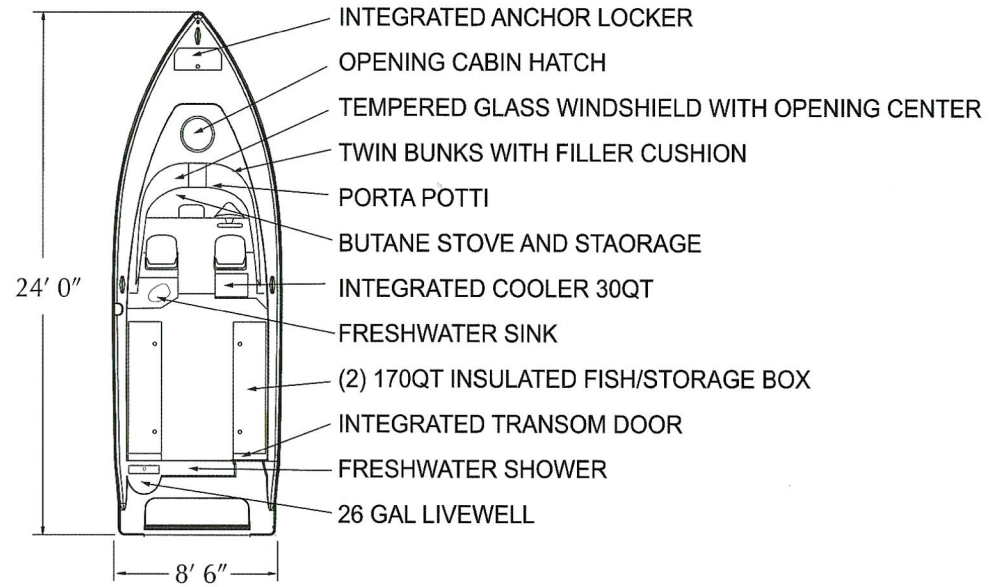

"With its roomy layout and safety features, McKee Craft's Freedom 24 is a great boat for diving or family water sports. But its ride, range and fishability also define it as an excellent fish boat."

Dave Lear, MotorBoating Magazine



TACKLE CENTER



Cabin V-Berth



Large Fish Box

Safety

- 100% Unsinkable – pressure foam filled
- Bilge pump, 1500 gph with automatic float switch
- Bilge pump, backup 500 gph with automatic float switch
- Horn, flush mount stainless steel
- Meets or exceeds all applicable U.S. Coast Guard safety standards
- Molded non-skid on horizontal surfaces
- Navigation lights, international

Features

- 100% all composite construction - no wood no rot
- 10-year limited transferable structural hull warranty
- PBS - "Pressure Bonding System" closed cell foam core construction
- Ceramic micro fiber deck coring
- .090" aluminum backing plate system for all screw connections
- Premium ISO/NPG high flex gel coat vinyl ester barrier coat
- Cockpit accessible battery switch rigged for house and (2) cranking batteries (dual engines)
- Bow, forward casting deck
- Wrap around bow rail
- Tempered glass windshield with opening center
- Cabin, lockable access door
- Cabin, 3 pc. cushion set, marine fabric

Features cont.

- Cabin, bolster mid-back, with storage
- Cabin, mildew resistant half head liner
- Portable, butane stove and storage
- Livewell pump, 800 gph
- Livewell, aerated oval 26 Gal, L.E.D. lighted
- Rod holders, horizontal, 3 port and 3 starboard
- Tackle center, (4) drawer
- Fuel tank, welded aluminum, 146 gal fully accessible and serviceable
- Cleat, bow, 8" pop-up, stainless steel
- Cleat, spring line, (2) 8" pop-up, stainless steel
- Cleat, stern, (2) 8" pop-up, stainless steel
- Chocks, anchor, pop up, port and starboard
- Lighting, LED cockpit courtesy lights
- Lighting, reading light in cabin
- Macerated fishbox drainage
- Port light with screen, port and starboard
- Transom door with stainless steel latch
- Storage, 30qts. integrated cooler
- Storage, (2) insulated, 170 qts each
- Storage, anchor locker
- Storage, port and starboard drawers below captains chairs
- Storage, cabin accessible



Features cont.

- Storage, coaming boxes port and starboard
- Engine controls, recessed
- Instruments, military grade switches
- Cup holders, stainless steel
- Seating, deluxe captains chairs with folding foot rest
- Steering system, tilt hydraulic
- Steering wheel, polished stainless steel
- Trim tabs, Lenco sport tabs with indicators
- Sink, freshwater with folding SS faucet
- Water system, freshwater, 12.5 gal
- Saltwater wash down system
- Fresh water shower

Optional equipment list on back page

Freedom

22 Tournament Edition



SPECS

Overall Length	22'	Maximum Power	300 hp	Fuel Capacity	120 gal
Beam	8'6"	Recommended Power	250 hp	Interior Freeboard	26"
Draft	22"	Minimum Power	150 hp		
Approx. Boat Weight	3000 lbs	Transom Height	25"		
Persons Capacity	8	Deadrise at Transom	22°		

Shown with optional equipment

Powered by:



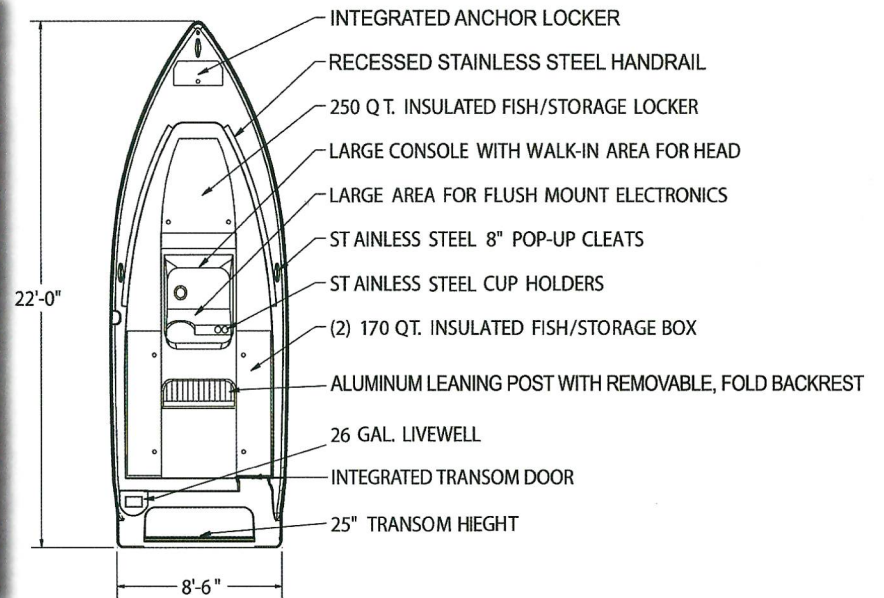

LEANING POST



CONSOLE WITH HYDRAULIC
TILT STEERING



LIVEWELL AND INTEGRATED
TRANSOM DOOR

"McKee Craft's construction gives you confidence and peace of mind... You've got to love a boat that simply can not sink..." *Boating Magazine*



Safety

- 100% Unsinkable – pressure foam filled
- Bilge pump, 1500 gph with automatic float switch
- Bilge pump, backup 500 gph with automatic float switch
- Deck accessible battery switch box
- Meets or exceeds all applicable U.S. Coast Guard safety standards
- Molded non-skid on horizontal surfaces
- Navigation lights, international
- Rails, bow, elliptical recessed, stainless steel

Fishability

- Functional flush deck design
- Livewell pumps, 800 gph
- Livewell, aerated oval 26 Gal, L.E.D. lighted
- Rod holders, (4) leaning post mounted
- Tackle center, (6) drawer

Console

- Engine controls factory pre-rigged
- Head area, lockable

Console (cont.)

- Steering system, tilt hydraulic
- Steering wheel with power knob, offshore style polished stainless steel
- Windshield, Plexiglas
- Wiring system, multifunction w/ breaker panel & accessory

Construction

- .09" aluminum backing plate system for all screw connections
- 100% all composite construction – no wood no rot
- 10-year limited transferable structural hull warranty
- Ceramic micro fiber deck coring
- PBS – "Pressure Bonding System" closed cell foam core construction
- Premium ISO / NPG high flex gel coat for strong durable finish
- Rubrail heavy duty white vinyl, stainless steel insert
- Vinyl ester barrier coat

Cockpit & Deck

- 3" toe kick 360° around the cockpit
- Battery storage area
- Cambered floor for rapid self-bailing

Cockpit & Deck (cont.)

- Cleat, bow, 8" pop-up, stainless steel
- Cleat, spring line, (2) 8" pop-up, stainless steel
- Cleat, stern, (2) 8" pop-up, stainless steel
- Cockpit drains with 4 way flapper valve, stainless steel
- Fuel tank, welded aluminum, 120 gal fully accessible and serviceable
- Leaning post with removable backrest
- Lifting eye, (2) stern, stainless steel
- Lifting eye, bow, stainless steel
- Lighting, cockpit courtesy lights
- Manual and macerated fishbox drainage
- Molded transom door with stainless steel latch
- Pneumatic lift assist rams on all fish boxes, stainless steel
- Pop-up anchor chocks, stainless steel
- Storage, (2) insulated, 170 qts each
- Storage, anchor locker
- Storage, bow [1] insulated, 270 qt
- Twist latches on all box lids, stainless steel
- Saltwater washdown
- Freshwater washdown

Optional equipment list on back page

Marathon

196CC



SPECS

Overall Length	19' 6"	Swamped Capacity	3000 lbs	Transom Height	25"
Beam	8'0"	Persons Capacity	8	Deadrise at Transom	18°
Draft (Fully Loaded)	17"	Maximum Power	200 hp	Fuel Capacity	80 gal
Approx. Boat Weight (Dry)	1950 lbs	Recommended Power	150 hp	Interior Freeboard	21"
Maximum Weight Capacity	1850 lbs	Minimum Power	115 hp		

Powered by:



YAMAHA

Shown with optional equipment



INSULATED BOW FISH/
STORAGE BOX

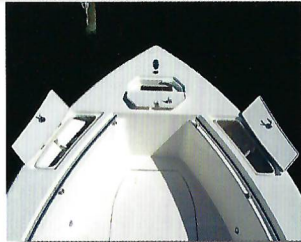

ANCHOR AND ROD
STORAGE



CONSOLE AND DASH
LAYOUT

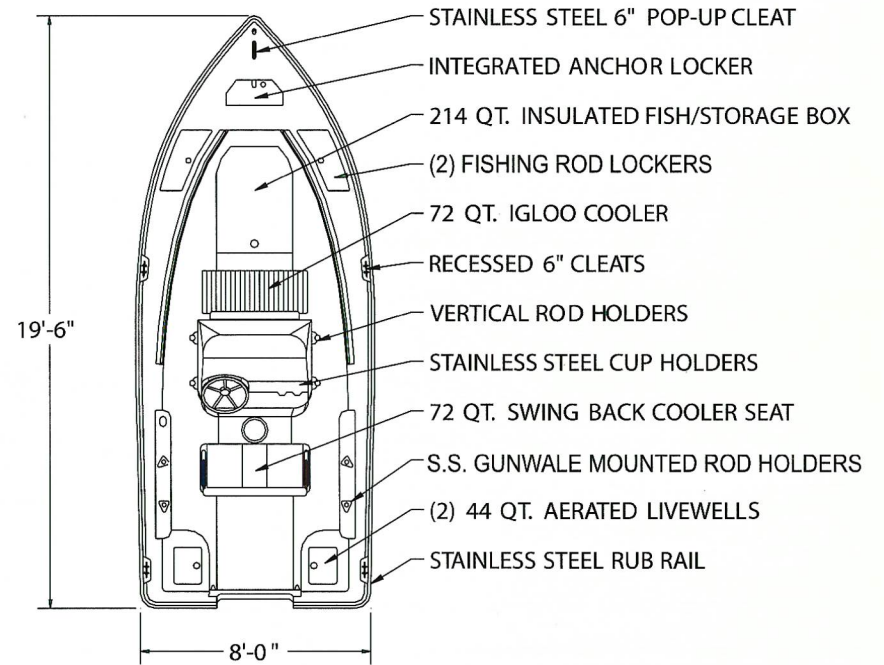

The 196 has time-tested fishing amenities to make the most of recreation angling trips inshore or nearshore."

Boating Life Magazine



Safety

100% unsinkable – pressure foam filled
 Bilge pump, 500 gph with automatic float switch
 Horn, flush mount stainless steel
 Meets or exceeds all applicable U.S. Coast Guard safety standards
 Molded non-skid on horizontal surfaces
 Navigation lights, international with folding stern light
 Rail, console, stainless steel
 Rails, bow, recessed stainless steel
 Reduced volume bilge design
 Self-bailing deck

Console

Console, raised inner floor for dry storage, large access door, lockable
 Engine controls factory pre-rigged
 Steering wheel, ultra-grip five spoke, stainless steel
 Steering, Uflex Rotech® planetary gear design
 Windshield, Plexiglas

Fishability

Gunwale rod lockers (2), locking
 Functional "deck forward" design
 Livewells, (2) aerated oval 44 qt, L.E.D. lighted
 Saltwater washdown system
 Rod storage, (4) vertical
 Rod storage, (6) horizontal
 Tackle center, (4) drawer
 Trolling motor wiring kit

Construction

.09" aluminum backing plate system for all screw connections
 100% all composite construction – no wood no rot
 10-year limited transferable structural hull warranty
 Ceramic micro fiber deck coring
 PBS – "Pressure Bonding System" closed cell foam core construction
 Premium ISO / NPG high flex gel coat for strong durable finish
 Rubrail, heavy-duty white vinyl with stainless steel insert

Cockpit & Deck

72 qt Igloo cooler with cushion
 Battery storage area in console
 Bow eye, stainless steel
 Cleat, bow, 6" pop-up stainless steel
 Cleat, spring line, 6" (2) stainless steel
 Cleat, stern, 6" (2) stainless steel
 Deck latches, stainless steel with locks
 Fuel tank, aluminum, 80 gal
 Gunwale boards, fiberglass, with (4) stainless steel rod holders
 Hatch lift assist, stainless steel
 Lifting eye, (2) stern, stainless steel
 Lighting, cockpit lights
 Seating, 72qt swing back cooler seat
 Self bailing cockpit drains with flapper valve, stainless steel
 Storage, all boxes completely insulated
 Storage, anchor locker
 Storage, insulated, 214 qt fishbox
 Wiring system, integrated military-grade switches and fuse block

Optional equipment list on back page

Marathon

196DC



SPECS

Overall Length	19' 6"
Beam	8'0"
Draft (Fully Loaded)	17"
Approx. Boat Weight (Dry)	1950 lbs
Maximum Weight Capacity	1850 lbs

Swamped Capacity	3000 lbs
Persons Capacity	8
Maximum Power	200 hp
Recommended Power	150 hp
Minimum Power	115 hp

Transom Height	25"
Deadrise at Transom	18°
Fuel Capacity	80 gal
Interior Freeboard	21"

Shown with optional equipment

Powered by:

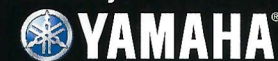



CONSOLE WITH COOLER



OPTIONAL BOW RAIL



CONSOLE WITH ELECTRONICS BOX

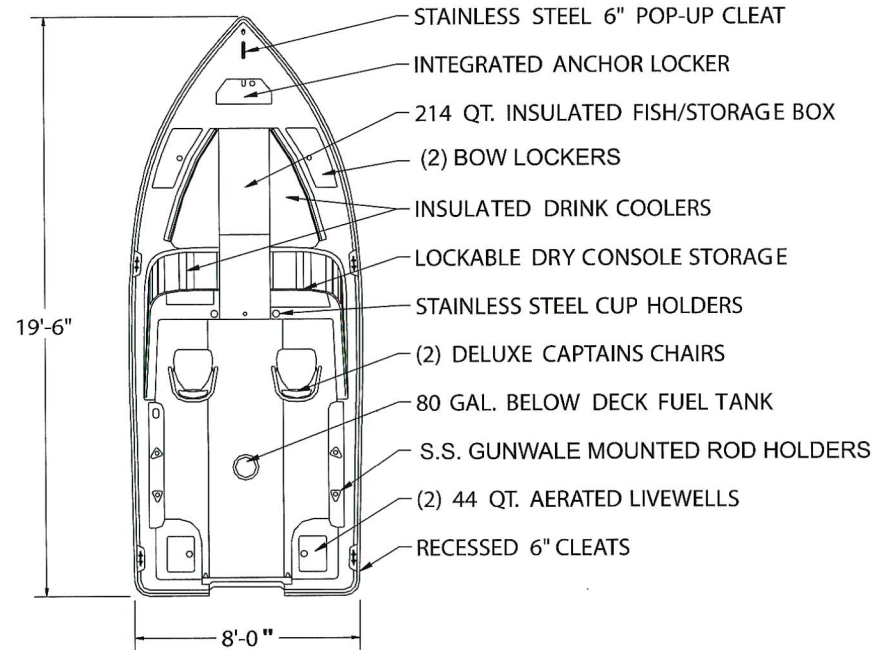

"You build an outstanding boat. I have gone to many boat shows since I purchased my boat and have yet to find anything that comes close. Simply put, you provide the most boat for the dollar in the market today."

...Eric Peek, FL



Safety

- 100% unsinkable – pressure foam filled
- Bilge pump, 500 gph with automatic float switch
- Handrail, passenger, stainless steel
- Horn, flush mount stainless steel
- Meets or exceeds all applicable U.S. Coast Guard safety standards
- Molded non-skid on horizontal surfaces
- Navigation lights, international with folding stern light
- Rails, bow, recessed stainless steel
- Reduced volume bilge design
- Self-bailing deck

Fishability

- Livewells, (2) aerated oval 44qt, L.E.D. lighted
- Saltwater washdown system
- Trolling motor wiring kit

Console

- Console storage areas [2] with large access door, lockable
- Consoles designed for maximum weather protection
- Dry storage area under both consoles
- Engine controls factory pre-rigged
- Steering, Uflex Rotech® planetary gear design
- Steering wheel, ultra-grip five spoke, stainless steel
- Windshield, walk-through tempered glass w/aluminum frame

Construction

- .09" aluminum backing plate system for all screw connections
- 100% all composite construction – no wood no rot
- 10-year limited transferable structural hull warranty
- Ceramic micro fiber deck coring
- PBS – "Pressure Bonding System" closed cell foam core construction
- Premium ISO / NPG high flex gel coat for strong durable finish
- Rubrail heavy duty white vinyl, stainless steel insert
- Vinyl ester barrier coat

Cockpit & Deck

- Battery storage area in console
- Bow eye, stainless steel
- Cleat, bow, 6" pop-up stainless steel
- Cleat, spring line, 6" (2) stainless steel
- Cleat, stern, 6" (2) stainless steel
- Cushion, bow (4 pc)
- Deck latches, stainless steel with locks
- Fuel tank, aluminum, 80 gal
- Gunwale boards, fiberglass, with (4) stainless steel rod holders
- Hatch lift assist, stainless steel
- Storage, (2) gunwale, locking
- Storage, insulated, (2) bow lockers
- Storage, insulated, console drink cooler
- Storage, insulated, water ski locker
- Lifting eye, (2) stern, stainless steel
- Lighting, cockpit lights
- Seating, (2) deluxe captain's chairs with sliders
- Self bailing cockpit drains with flapper valve, stainless steel
- Storage, all boxes completely insulated
- Storage, anchor locker

Optional equipment list on back page

Marathon

184CC



SPECS

Overall Length	18'4"	Swamped Capacity	3000 lbs	Transom Height	25"
Beam	8'0"	Persons Capacity	8	Deadrise at Transom	18°
Draft (Fully Loaded)	17"	Maximum Power	175hp	Fuel Capacity	65 gal
Approx. Boat Weight (Dry)	1750 lbs	Recommended Power	115 hp	Interior Freeboard	21"
Maximum Weight Capacity	1850 lbs	Minimum Power	90 hp		

Shown with optional equipment

Powered by:





INSULATED BOW FISH/STORAGE BOX



TACKLE CENTER WITH ROD HOLDERS



OPTIONAL LEANING POST

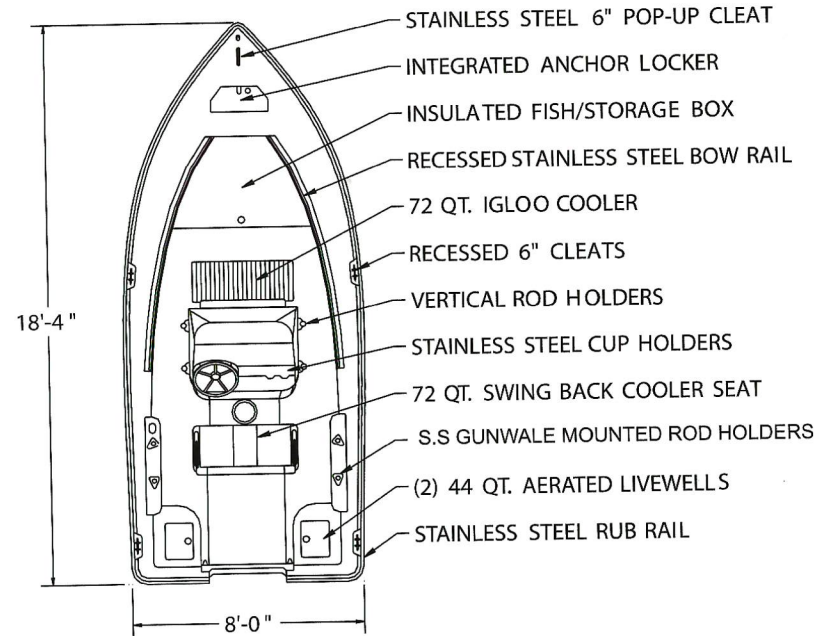

"You build an outstanding boat. I have gone to many boat shows since I purchased my boat and have yet to find anything that comes close. Simply put, you provide the most boat for the dollar in the market today."

...Eric Peek, FL



Safety

- 100% unsinkable – pressure foam filled
- Bilge pump, 500 gph with automatic float switch
- Horn, flush mount stainless steel
- Meets or exceeds all applicable U.S. Coast Guard safety standards
- Molded non-skid on horizontal surfaces
- Navigation lights, international with folding stern light
- Rail, console, stainless steel
- Rails, bow, recessed stainless steel
- Reduced volume bilge design
- Self-bailing deck

Console

- Console, raised inner floor for dry storage, large access door, lockable
- Engine controls factory pre-rigged
- Steering wheel, ultra-grip five spoke, stainless steel
- Steering, Uflex Rotech® planetary gear design
- Windshield, Plexiglas

Fishability

- Functional forward casting deck design
- Livewells, (2) aerated oval 44 qt, L.E.D. lighted
- Salt water washdown system
- Rod storage, (8) vertical
- Tackle center, (4) drawer

Construction

- .09" aluminum backing plate system for all screw connections
- 100% all composite construction – no wood no rot
- 10-year limited transferable structural hull warranty
- Ceramic micro fiber deck coring
- PBS – "Pressure Bonding System" closed cell foam core construction
- Premium ISO / NPG high flex gel coat for strong durable finish
- Rubrail, heavy-duty white vinyl with stainless steel insert

Cockpit & Deck

- 72 qt Igloo cooler with cushion
- Battery storage area in console
- Bow eye, stainless steel
- Cleat, bow, 6" pop-up stainless steel
- Cleat, spring line, 6" (2) stainless steel
- Cleat, stern, 6" (2) stainless steel
- Deck latches, stainless steel with locks
- Fuel tank, aluminum, 80 gal
- Gunwale boards, fiberglass, with (4) stainless steel rod holders
- Hatch lift assist, stainless steel
- Lifting eye, (2) stern, stainless steel
- Lighting, cockpit lights
- Seat, 72 qt. flip back cooler
- Self bailing cockpit drains with flapper valve, stainless steel
- Storage, anchor locker
- Storage, insulated, fishbox
- Wiring system, integrated military-grade switches and fuse block

Optional equipment list on back page

Marathon

172CC



SPECS

Overall Length	17' 2"	Swamped Capacity	2650 lbs	Transom Height	20"
Beam	7'0"	Persons Capacity	5	Deadrise at Transom	18°
Draft (Fully Loaded)	11"	Maximum Power	115 hp	Fuel Capacity	36 gal
Approx. Boat Weight (Dry)	1250 lbs	Recommended Power	90 hp	Interior Freeboard	19"
Maximum Weight Capacity	1260 lbs	Minimum Power	60 hp		

Shown with optional equipment

Powered by:

EVINRUDE





158 QT STORAGE/FISHBOX



FLIP BACK COOLER SEAT



CONSOLE WITH TACKLE CENTER

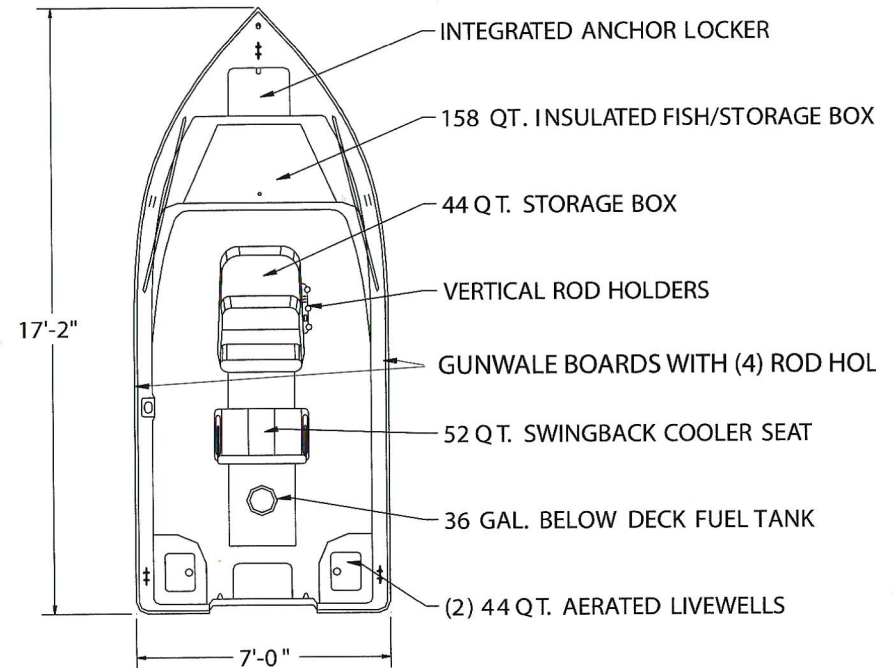

"I can take my 172 into skinny water thanks to the tunnel and it handles the afternoon chop with ease."

...David Weatherby, SC



Safety

- 100% unsinkable – pressure foam filled
- Bilge pump, 500 gph with automatic float switch
- Horn, flush mount stainless steel
- Meets or exceeds all applicable U.S. Coast Guard safety standards
- Molded non-skid on horizontal surfaces
- Navigation lights, international with folding stern light
- Rail, console, stainless steel
- Rails, bow, curved stainless steel, 4' x 4"
- Reduced volume bilge design
- Self-bailing deck

Console

- Console storage with large access door, lockable
- Console, ergonomic space-saving design
- Dry console storage area
- Engine controls factory pre-rigged
- Steering wheel, ultra-grip five spoke, stainless steel
- Steering, Uflex Rotech® planetary gear design
- Windshield, plexiglas

Fishability

- 5" lift tunnel for shallow water access
- Forward casting deck, snag-free
- Gunwale boards, fiberglass, with (4) stainless steel rod holders
- Livewells, (2) aerated oval 44 qt, L.E.D. lighted
- Salt water washdown system
- Rod storage rack, (3) vertical
- Tackle center (4) drawer

Construction

- 09" aluminum backing plate system for all screw connections
- 100% all composite construction – no wood no rot
- 10-year limited transferable structural hull warranty
- Ceramic micro fiber deck coring
- PBS – "Pressure Bonding System" closed cell foam core construction
- Premium ISO / NPG high flex gel coat for strong durable finish
- Rubrail heavy duty white vinyl, stainless steel insert

Cockpit & Deck

- Battery box, in console
- Bow eye, stainless steel
- Cleat, bow, 6" (1) stainless steel
- Cleat, stern, 6" (2) stainless steel
- Fuel tank, aluminum, 36 gal (below deck)
- Lifting eye, (2) stern, stainless steel
- Lighting, cockpit lights
- Seat, forward of console w/cushion & backrest
- Seat, rear corner jump seats
- Seat, swingback 52 qt cooler
- Self bailing cockpit drains with flapper valve, stainless steel,
- Storage, 44 qt under console seat
- Storage, all boxes completely insulated and drain directly overboard
- Storage, insulated full beam, 158 qt, fishbox
- Storage, anchor locker
- Wiring system, integrated with back lit switches and fuse block

Optional equipment list on back page

Marathon

172DC



SPECS

Overall Length	17' 2"
Beam	7'0"
Draft (Fully Loaded)	11"
Approx. Boat Weight (Dry)	1250 lbs
Maximum Weight Capacity	1260 lbs

Swamped Capacity	2650 lbs
Persons Capacity	5
Maximum Power	115 hp
Recommended Power	90 hp
Minimum Power	60 hp

Transom Height	20"
Deadrise at Transom	18°
Fuel Capacity	36 gal
Interior Freeboard	19"

Shown with optional equipment

Powered by:
 **YAMAHA**

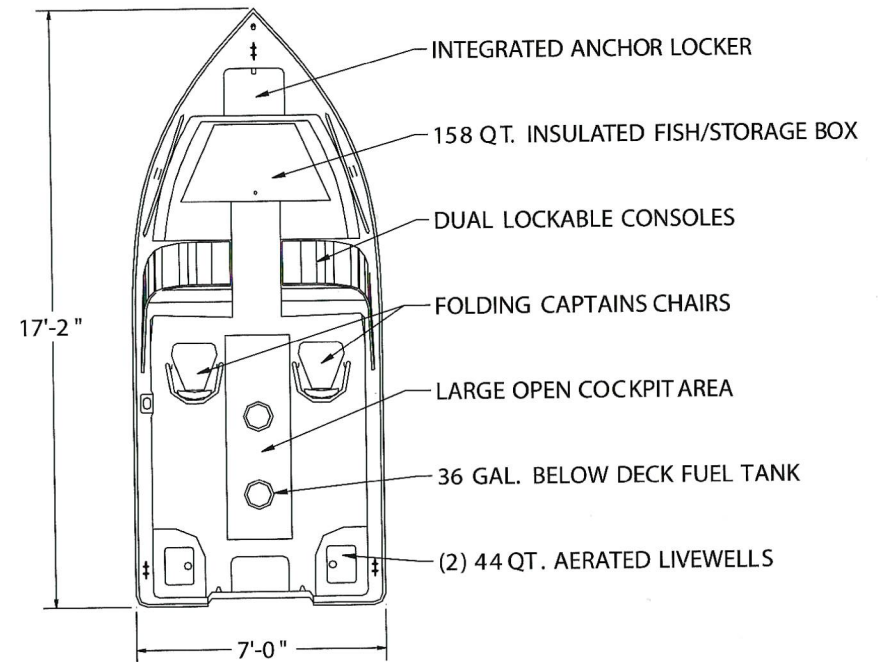

STARBOARD CONSOLE



OPTIONAL LIVEWELL CUSHIONS

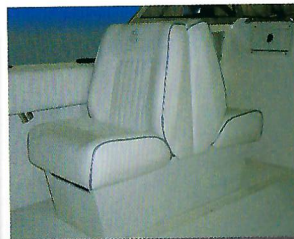

OPTIONAL LOUNGE SEAT

"Great layout for fishing and skiing..." **Nick Craft, GA**



Safety

- 100% unsinkable – pressure foam filled
- Bilge pump
- Horn, flush mount stainless steel
- Meets or exceeds all applicable U.S. Coast Guard safety standards
- Molded non-skid on horizontal surfaces
- Navigation lights, international with folding stern light
- Rail, console, stainless steel
- Rails, bow, curved stainless steel, 4' x 4"
- Reduced volume bilge design
- Self-bailing deck

Console

- Console storage areas [2] with large access door, lockable
- Consoles designed for maximum weather protection
- Dry storage area under both consoles
- Engine controls factory pre-rigged
- Steering, Uflex Rotech® planetary gear design
- Steering wheel, ultra-grip five spoke, stainless steel
- Windshield, walk-through tempered glass w/aluminum frame

Fishability

- 5" lift tunnel for shallow water access
- Forward "snag-free" casting deck
- Livewells, (2) aerated oval 44 qt, L.E.D. lighted
- Salt water washdown system

Construction

- 09" aluminum backing plate system for all screw connections
- 100% all composite construction – no wood no rot
- 10-year limited transferable structural hull warranty
- Ceramic micro fiber deck coring
- PBS – "Pressure Bonding System" closed cell foam core construction
- Premium ISO / NPG high flex gel coat for strong durable finish
- Rubrail heavy duty white vinyl, stainless steel insert

Cockpit & Deck

- Bow eye, stainless steel
- Cleat, bow, 6" stainless steel
- Cleat, stern, 6" (2) stainless steel
- Cockpit, large aft floor area for maximum fishability
- Fuel tank, aluminum, 36 gal
- Glovebox, lockable
- Lifting eye, (2) stern, stainless steel
- Lighting, cockpit lights
- Seating, (2) deluxe captain's chairs with sliders
- Seat, rear corner jump seats
- Self bailing cockpit drains with flapper valve, stainless steel.
- Storage, all boxes completely insulated and drain directly overboard
- Storage, insulated full beam, 158 qt, fishbox
- Storage, anchor locker
- Sunbrella® center flap wind block
- Wiring system, integrated with back lit switches and fuse block

Optional equipment list on back page

Bay Classic

185



SPECS

Overall Length	18' 4"
Beam	7'0"
Draft (Fully Loaded)	11"
Approx. Boat Weight (Dry)	1560 lbs
Maximum Weight Capacity	1640 lbs

Swamped Capacity	2850 lbs
Persons Capacity	8
Maximum Power	150 hp
Recommended Power	115 hp
Minimum Power	70 hp

Transom Height	20"
Fuel Capacity	35 gal
Interior Freeboard	19"

Shown with optional equipment

Powered by:



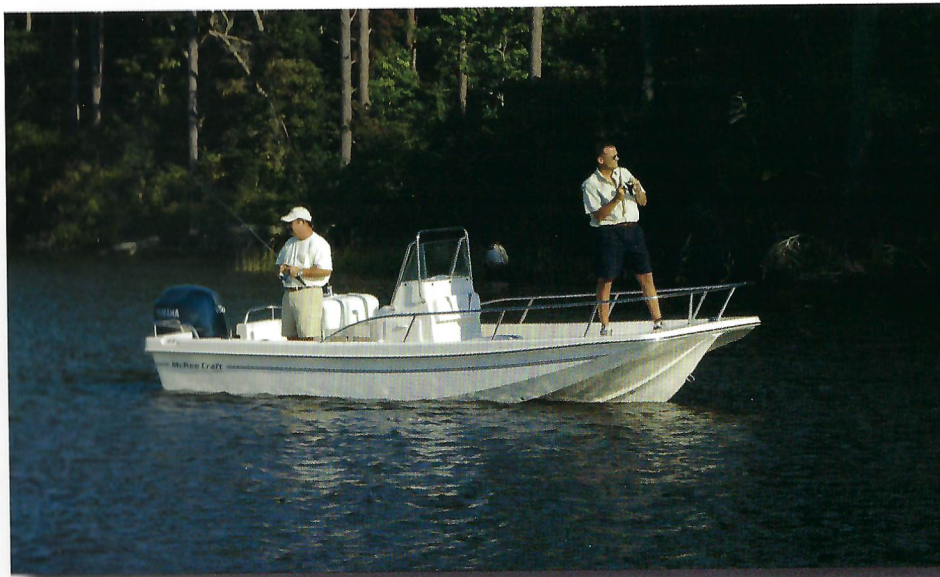

TACKLE CENTER WITH
ROD HOLDERS

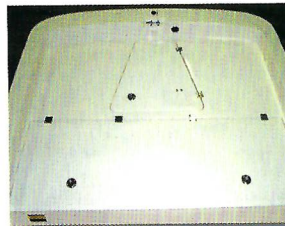

LARGE CASTING DECK



(2) 44 qt. LIVEWELLS

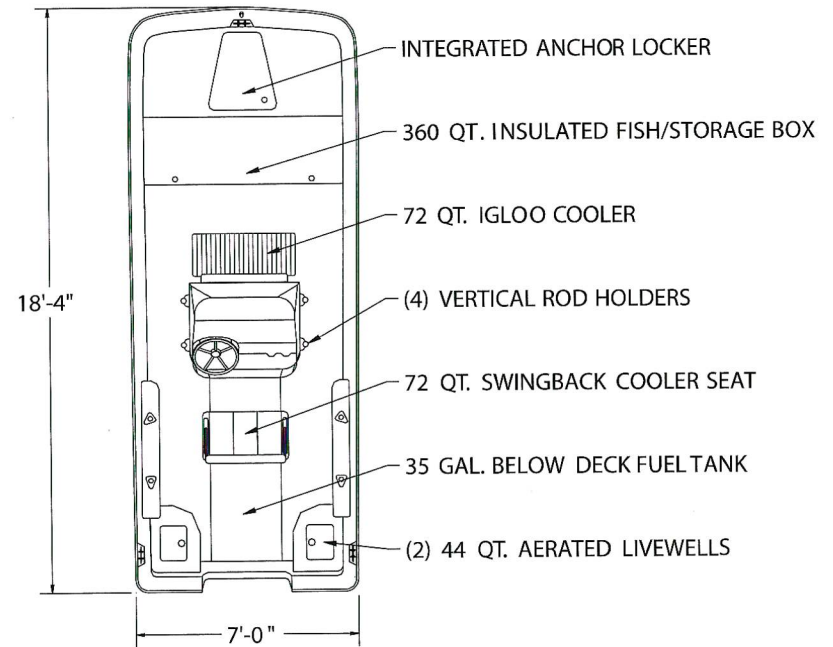

"Huge fishing area with a ton of storage... great for the shallows or the bay. " ...**Charles Rhodes, MD**



Safety

- 100% unsinkable – pressure foam filled
- Bilge pump, 500 gph with automatic float switch
- Horn, flush mount stainless steel
- Meets or exceeds all applicable U.S. Coast Guard safety standards
- Molded non-skid on horizontal surfaces
- Navigation lights, international with folding stern light
- Rail, console, stainless steel
- Stable cathedral hull design

Console

- Console storage with large access door, lockable
- Console, raised inner floor provides dry storage
- Engine controls factory pre-rigged
- Steering wheel, ultra-grip five spoke, stainless steel
- Windshield, Plexiglas

Fishability

- Forward "snag-free" casting deck, 29 sq ft
- Gunwale boards, fiberglass, with (4) stainless steel rod holders
- Livewells, (2) aerated oval 44 qt, L.E.D. lighted
- Salt water wash down system
- Rod storage, (4) vertical
- Tackle center (4) drawer

Construction

- .09" aluminum backing plate system for all screw connections
- 100% all composite construction – no wood no rot
- 10-year limited transferable structural hull warranty
- Ceramic micro fiber deck coring
- PBS – "Pressure Bonding System" closed cell foam core construction
- Premium ISO / NPG high flex gel coat for strong durable finish
- Rubrail, heavy duty white vinyl , stainless steel insert

Cockpit & Deck

- 72 qt Igloo cooler with cushion
- Bow eye, stainless steel
- Cambered floor for rapid self-bailing
- Cleat, bow, 6" recessed, stainless steel
- Cleat, stern, 6" recessed (2) stainless steel
- Fuel tank, welded aluminum, 35 gal (below deck)
- Lifting eye, (2) stern, stainless steel
- Seat, swingback 72 qt cooler
- Self bailing cockpit drains with flapper valve, stainless steel
- Steering, Uflex Rotech® planetary gear design
- Storage, all boxes completely insulated and drain directly overboard
- Storage, anchor locker
- Storage, insulated full beam, 360 qt, fishbox
- Trim tabs, Lenco
- Twist latches on all boxes, stainless steel
- Wiring system, integrated military-grade switches and fuse block

Optional equipment list on back page

Classic 16

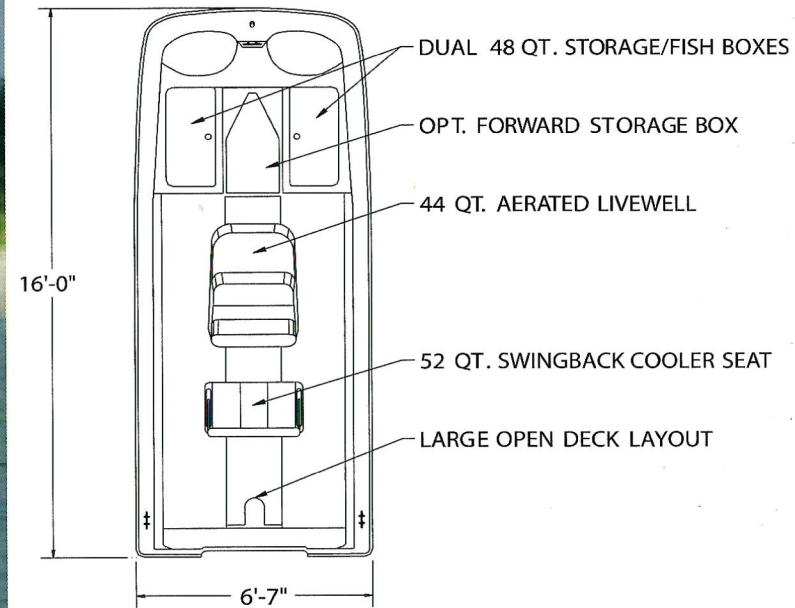
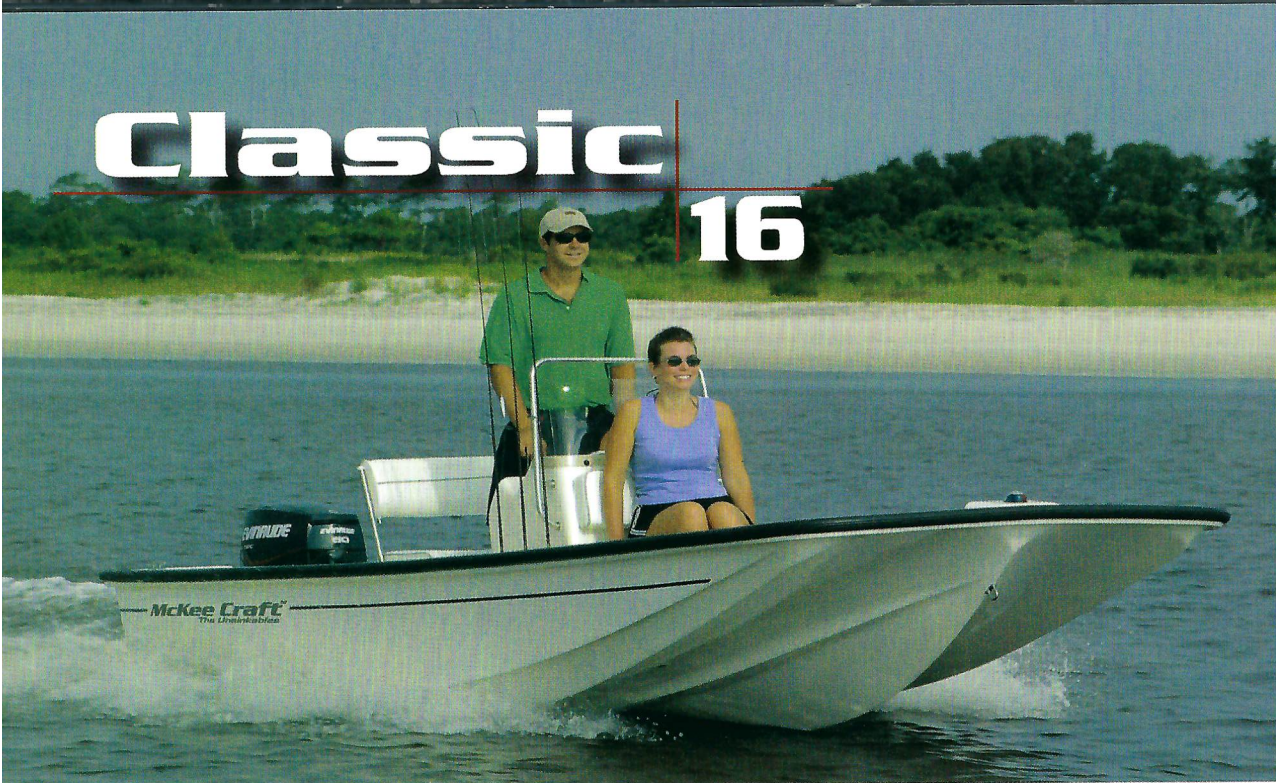

"It's a perfect boat for my family."

...Carl Motts, NJ



Safety

- 100% unsinkable – pressure foam filled
- Rail, console grab, stainless steel
- Meets or exceeds all applicable U.S. Coast Guard safety standards
- Molded non-skid on horizontal surfaces
- Navigation lights, international with folding stern light
- Stable cathedral hull design

Console

- Engine controls factory pre-rigged
- Space saving ergonomic console design
- Steering wheel, ultra-grip five spoke, stainless steel
- Steering, Uflex Rotech® planetary gear design
- Windshield, Plexiglas

Fishability

- Large forward casting area with optional forward storage box
- Livewell, aerated oval 44 qt

Construction

- .09" aluminum backing plate system for all screw connections
- 100% all composite construction – no wood no rot
- 10-year limited transferable structural hull warranty
- Ceramic micro fiber deck coring
- PBS – "Pressure Bonding System" closed cell foam core construction
- Premium ISO / NPG high flex gel coat for strong durable finish
- Rubrail, heavy duty vinyl, reinforced, uni-flex

Cockpit & Deck

- Bow eye, stainless steel
- Cleat, bow, 6", stainless steel
- Cleat, stern, (2) 6", stainless steel
- Lifting eye, (2) stern, stainless steel
- Seat, forward of console w/cushion & backrest
- Seat, swingback 52 qt cooler
- Storage, (2) insulated, 48 qt. fish boxes
- Storage, 44 qt under console seat
- Wiring system, modular, expandable



CLASSIC 16 CONSOLE



FLIP BACK COOLER SEAT



BOW STORAGE/FISH BOXES

Optional equipment list on back page

SPECS

Overall Length	16'
Beam	6'7"
Draft (Fully Loaded)	9"
Approx. Boat Weight (Dry)	990 lbs
Maximum Weight Capacity	1370 lbs

Swamped Capacity	2650 lbs
Persons Capacity	6
Maximum Power	115 hp
Recommended Power	70 hp
Minimum Power	40 hp

Transom Height	20"
Fuel Capacity	Portable
Interior Freeboard	18"

Shown with optional equipment

Powered by:



Classic 14

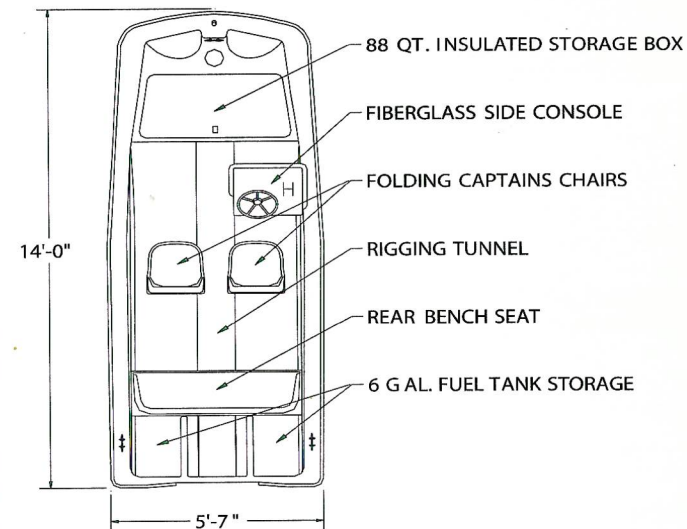
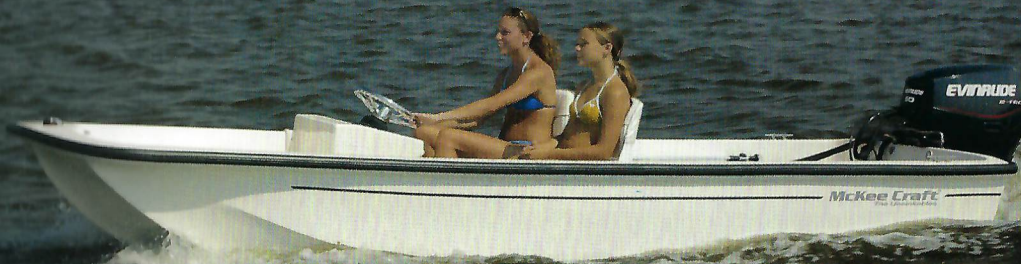

"Fast, dry, stable... Great boat for the kids."

...Robert Parker, NC



Safety

- 100% Unsinkable – pressure foam filled
- Meets or exceeds all applicable U.S. Coast Guard safety standards
- Molded non-skid on horizontal surfaces
- Navigation lights, international with folding stern light
- Stable cathedral hull design

Console

- Console, side mount
- Engine controls factory pre-rigged
- Steering wheel, ultra grip five spoke, stainless steel
- Steering, Uflex Rotech® planetary gear design

Cockpit & Deck

- Bow eye, stainless steel
- Cleats, bow, 6", stainless steel
- Cleats, stern, 6" (2) stainless steel
- Fuel tank storage area for (2) removable 6 gal
- Lifting eye, (2) stern, stainless steel
- Seating, (2) deluxe folding captain's chairs
- Seating, rear fiberglass bench
- Storage, bow ice box, 88 qt., with strain relief strap
- Wiring system, modular, expandable

Construction

- .09" aluminum backing plate system for all screw connections
- 100% all composite construction – no wood no rot
- 10-year limited transferable structural hull warranty
- Ceramic micro fiber deck coring
- PBS – "Pressure Bonding System" closed cell foam core construction
- Premium ISO / NPG high flex gel coat for strong durable finish
- Rubrail, heavy duty vinyl, reinforced, uni-flex
- Vinyl ester barrier coat

Optional equipment list on back page

SPECS

Overall Length	14'	Swamped Capacity	1750 lbs
Beam	5'7"	Persons Capacity	4
Draft (Fully Loaded)	7"	Maximum Power	65 hp
Approx. Boat Weight (Dry)	665 lbs	Recommended Power	50 hp
Maximum Weight Capacity	890 lbs	Minimum Power	25 hp

Transom Height	20"
Fuel Capacity	Portable
Interior Freeboard	15"

Shown with optional equipment

Powered by:



Available Options

	Freedom 28 TE	Freedom 28 FS	Freedom 23/24 TE	Freedom 24 FS	Freedom 24 EX	Freedom 22 TE		Marathon 196CC	Marathon 1960C	Marathon 184CC	Marathon 172CC	Marathon 1720C		Bay Classic 185	Classic 16	Classic 14
Colored hull sides (4 selections)	0	0	0	0	0	0		0	0	0	0	0		0	-	-
Boarding ladder, retractable	0	0	0	0	0	-		-	-	-	-	-		-	-	-
Boarding ladder, removable	-	-	-	-	-	0		-	-	-	-	-		-	-	-
Platform boarding ladder, fiberglass w/ two step ladder & handrail	-	-	-	-	-	-		0	0	0	0	0		0	-	-
Compass 3" flushmount	0	0	0	0	0	0		0	0	0	0	0		0	0	-
Cockpit bolsters	0	S	0	S	0	0		0	0	0	0	-		0	-	-
Cushion(s), bow	-	S	-	S	-	-		-	S	0	0	0		0	0	-
Cushion, livewell w/ brackrest	-	-	-	-	-	-		0	0	0	0	0		0	-	-
Leaning post with (4) rod holders	S	S	S	S	-	S		0	-	0	-	-		0	-	-
Seat, Tempress bow fishing chair, removable	-	-	-	-	-	-		0	-	0	0	0		0	0	0
Seat, Captains chair (2) upgrade	-	-	-	-	S	-		0	-	0	-	-		0	-	-
Seats, lounge seat upgrade (portside exchange)	-	-	-	-	-	-		-	0	-	-	0		-	-	-
Marine head with holding tank	0	0	0	0	-	-		-	-	-	-	-		-	-	-
Tournament tackle center	0	0	0	0	-	0		0	-	-	-	-		-	-	-
Bimini top, Sunbrella w/SS hardware & fasteners	-	-	-	-	-	-		0	-	0	0	-		0	0	-
Deluxe top, Sunbrella, w/ SS hardware & fasteners	-	-	-	-	0	-		-	0	-	-	0		-	-	-
Side curtains for Deluxe top	-	-	-	-	0	-		-	0	-	-	0		-	-	-
Console electronics box, lockable	0	0	0	0	-	0		-	0	-	-	0		-	-	-
T-top with Weblon top	0	0	0	0	-	0		0	-	0	-	-		0	-	-
T-top with 15' outriggers, Weblon top	0	0	0	0	-	0		-	-	-	-	-		-	-	-
T-top, hardtop, fiberglass with 15' outriggers	0	0	0	0	0	0		-	-	-	-	-		-	-	-
Console spray curtain kit	0	0	0	0	-	0		0	-	0	-	-		0	-	-
Gull wing kit (requires spray curtain kit)	0	0	0	0	-	0		-	-	-	-	-		-	-	-
Foldaway rear bench seat	0	0	0	0	-	-		-	-	-	-	-		-	-	-
Foldaway aluminum front step	S	-	S	-	-	0		-	-	-	-	-		-	-	-
Rails, stern, SS, corner	-	-	-	-	-	-		0	0	0	0	0		0	-	-
Rails, bow, SS, wraparound	-	-	-	-	-	-		-	0	-	-	0		0	0	-
Rails, side, SS 6' x 6"	-	-	-	-	-	-		-	-	-	-	-		0	0	0
Rails, side SS 9' x 6"	-	-	-	-	-	-		-	-	-	-	-		0	0	-
Rails side SS 11' x 6"	-	-	-	-	-	-		-	-	-	-	-		0	0	-
Rod storage rack (3) vertical	-	-	-	-	-	-		-	-	-	-	-		-	0	-
Trim tabs	S	S	S	S	S	0		-	-	-	-	-		S	-	-
Steering upgrade, tilt hydraulic	S	S	S	S	S	S		0	0	0	0	0		0	-	-
Transom splash board, drop in	-	-	-	-	-	-		0	0	0	0	0		0	-	-
Lifting eye, bow, SS	-	-	-	-	-	-		0	0	0	0	0		0	0	0
Bilge pump	S	S	S	S	S	S		S	S	S	S	S		S	0	0
Fuse block, ATO	S	S	S	S	S	S		S	S	S	S	S		S	0	0
Trolling motor wiring kit	-	-	-	-	-	-		S	S	0	0	0		0	0	0
Windless, electric, bow mounted	0	0	0	0	0	0		-	-	-	-	-		-	-	-

Featured Options



3" Compass



Rear Livewell Cushions



Removable Bow Fishing Chair



Stern Rails

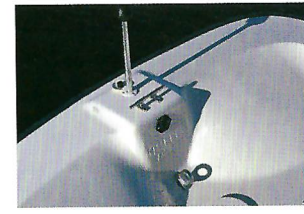

Trolling Motor Wiring Kit

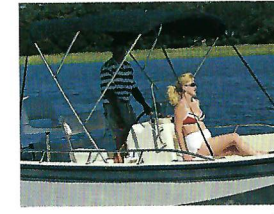

Bimini Top



Rear Bench Seat



Tilt, Hydraulic Steering



Bow Rail

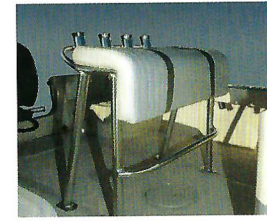

Leaning Post



Factory Installed T-Top



Swim Platform

Hull Color Options



Carolina Blue



Fighting Lady Yellow



Aqua Mist



Stars & Stripes Blue

COMMERCIAL DIVISION

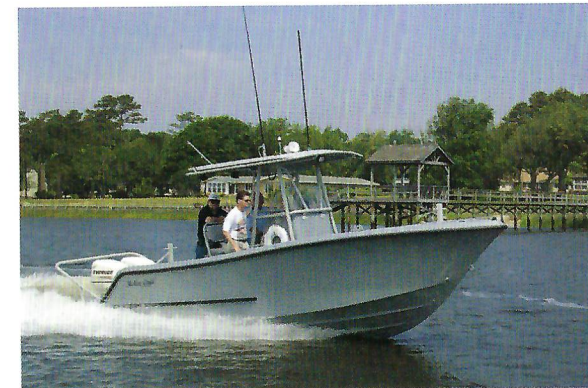



A WINNING COMBINATION



No other company understands the needs of a fisherman like Yamaha. From the professional angler to the weekend warrior, Yamaha's line of four stroke engines are sure to please. Yamaha prides itself on offering top-of-the-line outboard engines that give boat owners the best of all options. When power, reliability, and unsurpassed performance time after time is what you desire, then nothing will satisfy you like a Yamaha.

Factory Installed with



When you want the best



YAMAHA

150

FOUR STROKE

McKee Craft
The Unsinkables

MARATHON
1960C



McKee CraftTM
The Unsinkables



P.O. Box 623/404 Sandy Street • Fairmont, NC 28340 • 910.628.0926 • Fax 910.628.9598

www.mckeecraft.com

©2006 Lanness K. McKee & Co., Inc.



McKee Craft strives to offer the best quality & safest boats on the water. As a result, McKee Craft reserves the right to make changes in specifications, options, standard features, color schemes and discontinue models at any time without notice or obligation. Please contact your local dealer or the factory for additional information.

You're in command. Boat safely, take a boating education course and get a Vessel Safety Check for your boat. For information call the U.S. Coast Guard Auxiliary at 1-800-368-5647, or www.cgaux.org or the United States Power Squadrons at 1-888-for-usps, www.usps.org

Printed in U.S.A. • Part# BRO 07.00A • \$3.50 Each