

ANALYSER sodium



The determination of sodium in low concentrations in the water-steam cycle is of great importance in power plants. On the one hand, this is due to the fact that the significance of sodium in corrosion processes has become more and more recognized over the last few years. On the other hand, this measurement procedure enables a fast monitoring of a leakage for instance in the condenser or the aperture in a cation filter or a mixed bed filter. Not least for that reason, the sodium measurement has become increasingly important with revising the VGB-guidelines (S-006 / S-010).

The AC6300 sodium is an analyser for the continuous measurement of dissolved sodium, even at the level of trace elements, and ideally suited for the operation in the water-steam cycle of power plants, for the control of full demineralisation units, desalination of sea water as well as in the semiconductor industry and electronics industry.

In order to enable a measurement without the influence of hydronium ions, the sample is conditioned to a value of pH 11 +/- 0.02 pH. The measurement is potentiometrically carried out by means of a special measuring sequence with an Na-sensitive electrode in combination with an Ag/AgCl-reference electrode:

Ag/AgCl(S) – buffer – Na+-sensitive glass membrane - alkalisied measuring solution - diaphragm - KCl-electrolyte gel - AgCl(S)/Ag.

The fluidics to the sodium analyser AC6300 sodium is illustrated below:

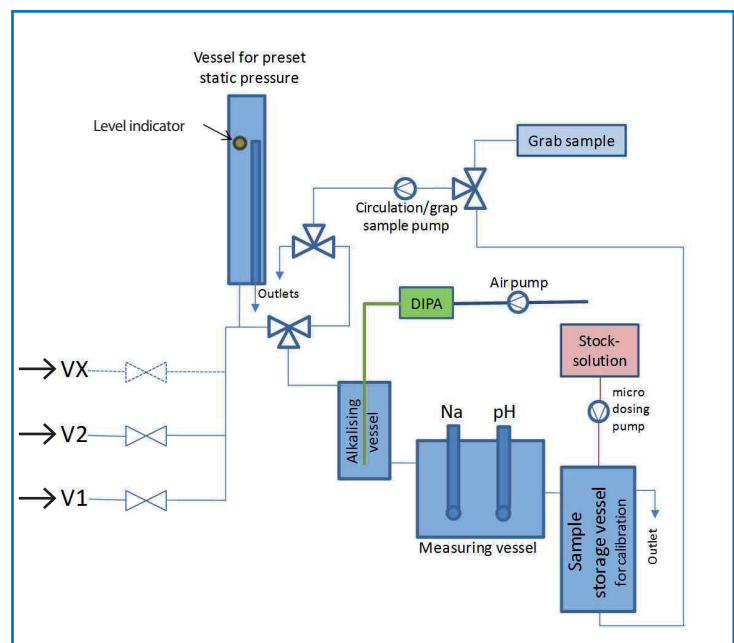

Technical features

- Very low consumption of conditioning materials: a maximum of 0.5 l DIPA/month at pH 7
- Automatic three-point calibration, adjustable time interval
- Individually selectable sequence and measuring duration in the multi-channel device
- Control and monitoring of the adjustable pH value
- Usable in the range (unbuffered) of pH 4-11
- Automatic temperature compensation
- Galvanically separated signal outputs
- Pressure regulator and easy-to-clean prefilter per channel
- Built-in sequencer for up to 6 sample channels
- Additional connection for the measurement of a laboratory sample

TECHNICAL DATA

AC6300 sodium

Device	AC6300 sodium
Measuring range	0.1 – 2000 ppb Na
Measuring principle	potential measurement of an ion-sensitive Na-electrode against a reference electrode
Display	graphic display, measuring value for each channel with point in time and operating condition
Accuracy	Maximum { ± 2 % of reading or ± 0.25 ppb}
Repeatability	Maximum { ± 2 % of reading; ± 0.25 ppb}
Calibration	three-point calibration with 10 ppb, 100 ppb and 1000 ppb Na ⁺ using standard addition
Reagents	0.5 l standard solution; 1.0 l diisopropylamine (alkaliation) or NH ₃ (solution)
Data interface	USB
Alarm outputs	two relays (1x for warnings and 1x for alarms), loading at 250 VAC/3 A, max. 24 VDC/3 A
Operation	password protection for the menu-led entry of threshold and calibration values, communication parameters, programming of calibration and measuring cycles
Analog outputs	up to 6 analog outputs 4...20 mA, max. load resistance 500 Ω
Response time	180 seconds (95 %)
Ambient conditions	+5 – +40 °C, storage and transport 0 – 50 °C ¹⁾ , relative humidity 30 – 95 %
Sample conditioning	at least 1.0 bar / 10 ⁻¹⁵ l/h, 10 ⁻⁴⁵ °C
Sample path	1- 6 input channels with application for maintaining a constant pressure, additional laboratory sample possible, pH adjustment to pH 11
Safety	no data loss after power blackout, data is stored in a memory
Power supply	100 – 240 VAC 50/60 Hz, 150 VA, battery-free parameter storage
Protective system	IP 65 (electrical parts)
Weight	30.0 kg
Dimensions	850 x 450 x 250 mm (HxWxD)
Space requirement for mounting	850 x 550 x 500 mm (HxWxD)

¹⁾ When exposed to temperatures around and under the freezing point, it has to be ensured that no water or reagents are inside the analyser! These have to be stored at temperatures above 0°C!



CONNECT+
IoT Solution Enabled

Labtech Electronics Private Limited

1/3, Kundrathur High Road, Periyapanicheri
Chennai-600128, TamilNadu, India
sales@labtech.co.in, www.labtech.co.in
+91 9840839875, 044-48605048

