

Zero Volume Industrial Flowmeter



OVAL GEAR FLOW METER



Applicable to all types of liquid measurements -
Crude oil, Diesel , Petrol etc.



CONNECT+

IoT Solution Enabled

Labtech Electronics Private Limited
1/3, Kundrathur High Road, Periyapanicheri
Chennai-600128, TamilNadu, India
sales@labtech.co.in, www.labtech.co.in
+91 9840839875, 044-48605048



► 1. Application

Oval gear flow meter is a target word count accumulated round devices and light devices to zero volume flow meter is widely used in various industrial areas of the liquid flow control, applicable to all types of liquid measurements, such as crude oil, diesel , petrol and so on, with great range and high precision, convenient use and maintenance of the characteristics of different materials selected to meet the petroleum, chemical, pharmaceutical, food, metallurgy, electricity, transportation and other fields of liquid flow measurement.

► 2. The working principle and s tructure

Flowmeter is installed in the metering tank and the measurement of a pair of oval box gear, with the upper and lower cover an early Lunar sealed cavity (due to rotation of the gear, so sealing is not an absolute) as a unit of emissions. When measured by the pipe into the liquid flow meter, due to pressure generated by the Import and Export Department to promote a pair of differential gears for rotation, the constant measurement by cavity after the beginning of the Lunar liquid delivery to the exit, elliptical gear with each revolution time displacement is the product of four times the measured volume of liquid flow (the principle of Picture 1).

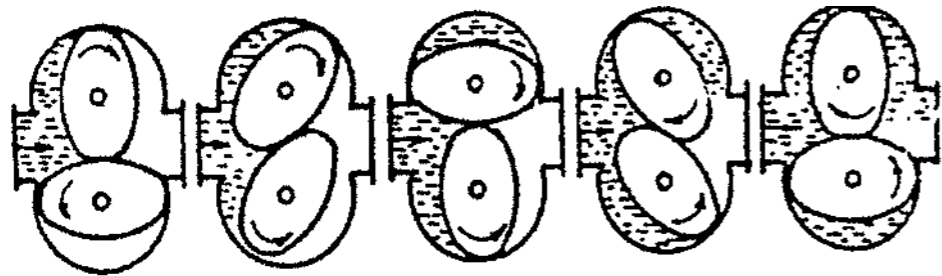

Picture 1 Schematic oval gear operatio

Mainly by the shell flow meter, counter, oval gear and coupling (magnetic coupling and sub-axial coupling), such as composition (structure see Picture 2).

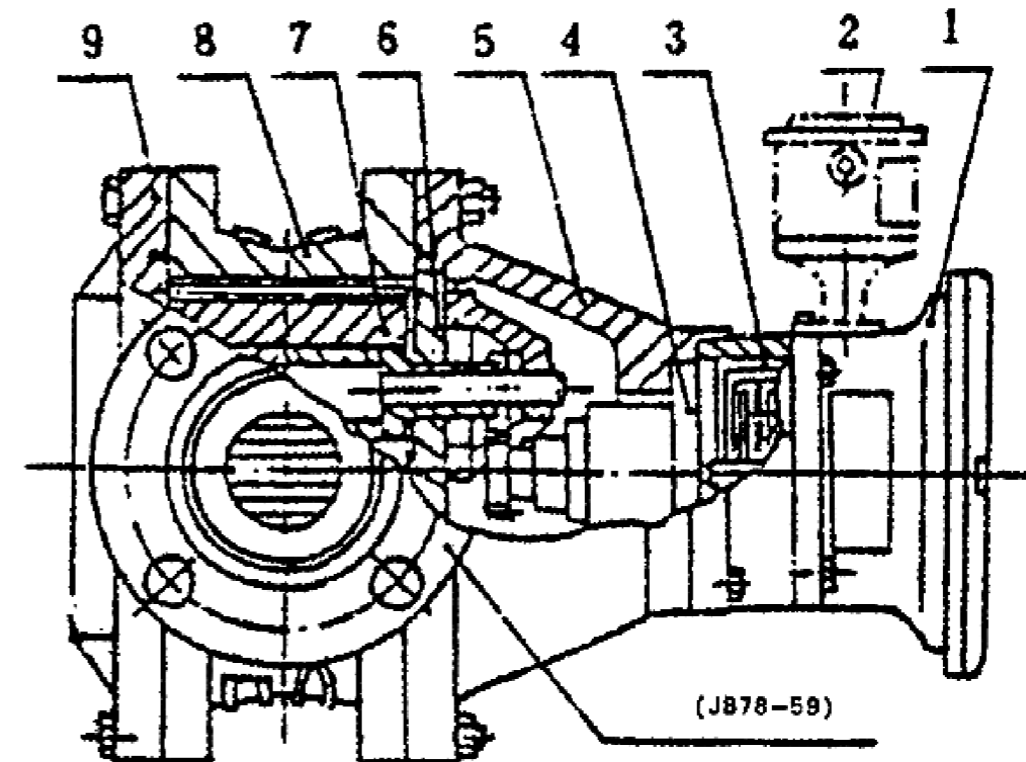

Picture 2 oval gear flowmeter structure

- | | |
|---|--------------------------|
| 1. <u>counter</u> | 6. <u>Flat</u> |
| 2. <u>letter device</u> | 7. <u>oval gear</u> |
| 3. <u>precision regulator (DN50 and above only)</u> | 8. <u>the shell</u> |
| 4. <u>sealing the coupling</u> | 9. <u>the rear cover</u> |
| 5. <u>the front cover</u> | |

3. Technical Data

(1) Ordinary cast iron type (A) , Steel type (E) , Stainless steel type (B)

Oval gear Flowmeter

Item	Model	LC-A cast iron	LC-E cast	LC-B stainless			
Pnmpa		1.0 1.6	2.5 4.0 6.4	1.0 1.6			
Tested liquid ciscosity		2~8 mpa.s					
Mesaured temperature of the liquid		-20℃ ~+100℃					
Flow range m ³ /h							
Nominal size	Model Accuracy	LC-A cast iron		LC-E cast		LC-B stainless	
		0.5	0.2	0.5	0.2	0.5	0.2
10		0.1~0.6	0.15~0.6	0.1~0.6	0.15~0.6	0.1~0.6	0.15~0.6
15		0.25~1.5	0.3~1.5	0.25~1.5	0.3~1.5	0.25~1.5	0.3~1.5
20		0.5~3	0.6~3	0.5~3	0.6~3	0.6~3	0.6~3
25		1~6	1.2~6	1~6	1.2~6	1.2~6	1.2~6
40		2.5~15	3~15	2.5~15	3~15	3~15	3~15
50		4~24	4.8~24	4~24	4.8~24	4.8~24	4.8~24
80		10~60	12~60	10~60	12~60	12~60	12~60
100		16~100	20~100	16~100	20~100	20~100	20~100
150		32~190	38~190	32~190	38~190	38~190	38~190
200		34~340	68~340	34~340	68~340	68~340	68~340

4. Size of oval gear flow meter

(A) Material in cast iron

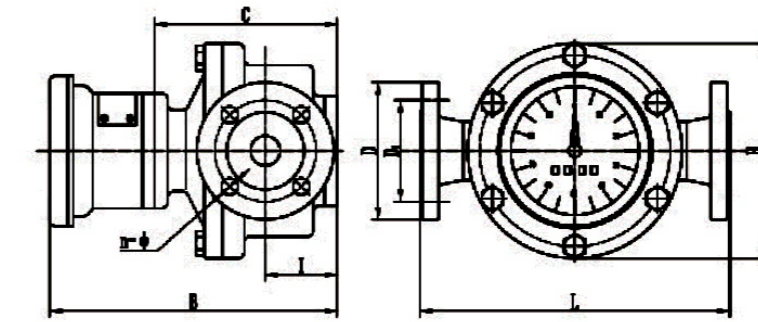

DN10-40

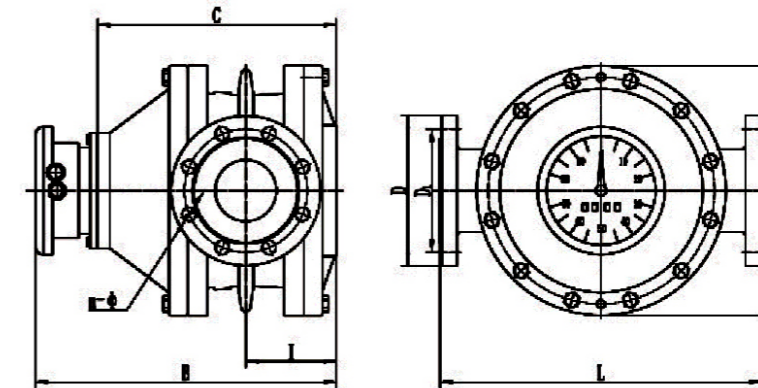

DN50-100

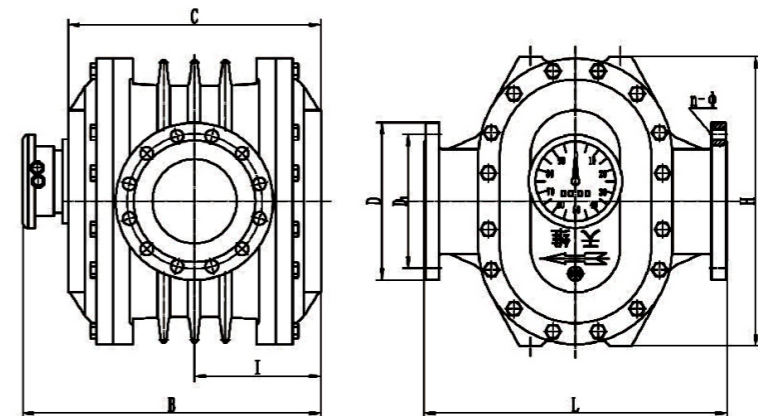

DN150, 200

Units: mm

DN(mm)	L	H	A	B	D	D1	N(NO.)	Φ
10	150	100	165	210	90	60	4	14
15	170	118	172	226	95	65	4	14
20	200	150	225	238	105	75	4	14
25	260	180	232	246	115	85	4	14
40	245	180	249	271	145	110	4	18
50	340	250	230	372	160	125	4	18
65	420	325	270	386	180	145	4	18
80	420	325	315	433	195	160	8	18
100	515	418	370	458	215	180	8	18
150	540	515	347	557	280	240	8	23
200	650	650	476	720	335	295	12	23

(B) The dimensions of steel type, steel blood type, high temperature steel oval gear flow meter size

Units: mm

DN(mm)	L	H	B	A	D	D1	N(NO.)	Φ
15	200	138	232	180	105	75	4	14
20	250	164	220	160	125	90	4	18
25	300	202	252	185	135	100	4	18
40	300	202	293	208	165	125	4	23
50	384	262	394	312	175	135	4	23
80	450	337	452	332	210	170	8	23
100	555	442	478	310	250	200	8	25
150	540	510	557	347	300	250	8	26
200	650	650	720	476	36	310	12	26

Cast iron, cast steel oval gear flow meters type high-temperature size: DN15 ~ DN25, A, B according to the table, data size plus 160mm extension tube heat: DN40 ~ DN80, A, B-size table size increases by thermal extension of 300mm pipe, rest size of the corresponding size table Ibid

(C) Type of stainless steel oval gear flow meter size

Units: mm

DN(mm)	L	H	B	A	D	D1	N(NO.)	Φ
15	208	120	228	172	95	65	4	14
20	236	150	238	225	105	75	4	14
25	287	195	246	232	115	85	4	14
40	265	178	349	265	145	110	4	18
50	265	178	349	265	160	125	4	18
65	365	260	436	319	180	145	4	18
80	420	305	459	324	200	160	8	18
100	515	400	554	373	220	180	8	18
150	540	515	607	397	280	240	8	23

5. Flow meter installation

1. Should be thoroughly cleaned before installing pipes, and pre-installed in the flow meter filter to prevent debris entering the flowmeter. Measured liquid containing gas is air separator should be installed.
2. Attention should be paid must be the oval gear flowmeter An Chengxin axis horizontal position, that is, the horizon and vertical dial. Regulation of traffic and start to close the valve should be installed on the meter side of the Import and Export.
3. The arrows point to the shell flow meter should be installed with the liquid pipe flow direction.
4. Continuous flow of the pipeline, the level of the installation of flow meter bypass valve should be fitted with pipes, so regular cleaning and maintenance. Vertical pipe flow meter should be installed in the bypass pipe to prevent debris from falling into the instrument within.
5. Flow meter installed in the right conditions, for ease of reading, according to the needs of the counter rotating 180° or 90° installation requirements

6. Cautions

1. No water flowmeter test.
2. To start or stop when the gate valve should be slow to prevent a sudden shock, and should prevent backflow.
3. Flowmeter repair, there shall be no demolition of the rear cover so as to avoid re-generated when the impact of changes to the precision accuracy.

7. Error calculation and adjustment

(A) The basic error of flow meter, flow test points by the time measured were determined using the following equation: (volume method)

$$E = \frac{V_m - V}{V} \times 100\%$$

E-meter error (generally refers to the cumulative error) the two digits.

V_m-meter measured value (that is, that value)

V-, as amended, the flow meter measured the value of the standard device (that is, the actual value) from the basic formula for calculating the error, when V_m > V, the basic error of flow meter "+" value, said flow meter go faster.

V_m < V, the basic error of flow meter "-" values that take the slow flow meter.

In order to make the basic error in the flowmeter error limit is often the need for error. That is installed in the counter through the replacement of a pair of adjustment gears (adjusted teeth) to change the mechanical transmission ratio, so that the flow meter to adjust the show deserves.

Error can not change the flow meter to adjust the flow characteristics, so that it curves in artificially in the new coordinate system.

In general, the provisions of (or actual use of) the flow range of the maximum and minimum flow test point margin of error of not more than the basic provisions of the basic error of precision limit can be adjusted through the error so that the basic error of flowmeter qualified . Flowmeter has been used, the general regulation of first gear with the original error test group, and then the error in accordance with the specific error to adjust the situation further.

8. Other

1, Stainless steel flow meter for 98% sulfuric acid, 60% nitric acid, 50% liquid caustic soda and other chemical measurement.

2, The instrument with light diesel oil factory test, do not use the school, the specific order in accordance with the national metrological verification JJG235-90 oval gear flowmeter standards.

9. Ordering Information

- 1.Name, model. Specifications, materials,
- 2.Medium temperature, pressure, flow range.
- 3.Medium or medium viscosity name.
- 4.Any special requirements (such as explosion-proof, etc.).
- 5.The name of order and delivery unit.

6.Detailed mailing address, telephone, telegraph, postal code,

7.Clearing units, the depositary bank, the account number.

8.Reached the station, contact.

9.You need to learn more about the product, please call for information.

10.Three bags of factory products, the use of follow-up maintenance period.

10. Common reasons for failure, troubleshooting

Fault phenomenon	Reasons	Measures	Remarks
Oval gear does not turn	1. Pipeline in debris. 2. Measured liquid containing more than debris, damaged filter. Debris to enter the table, the gear stuck.	Instrumentation and piping, repairing filter	/
Axial seal leakage coupling	Seal packing seal wear and tear or lack of oil	Pressed screw cap or replacement fill, seal oil loading	/
Pointer rotation instability, or when the stop-and-go	Indicators, such as pad volumes or loose pieces of rotating non-rotating flexible	Re-fastening, the elimination of the phenomenon of non-flexible	/
Negative bias in small-flow error is too large	Oval gear encounter with the metering box walls, the reasons for bearing wear, or deformation measurement box	Replacement of bearings, repair of varying tooth Department and gear metering box wall, so that rotational flexibility to ensure that the necessary clearance.	School is scheduled to be repaired
Error variation is too large	Contains a large pulse of fluid or gas.	Pulse or retrofitted to reduce gas separator	/
Error is too large, but the biggest difference between the minimum error does not exceed ± 1%	More than the use of, or maintenance, such as changes in space	Re-adjustment of the school seizure	/
Output device is no signal	1.The device installed in the wrong place	Re-adjust the position around before and after the mobile	/
	2.Then the anti-polarity	Into the re - : 1.“+” Then the red line 2.“-” Then the black line	