

Jeep Kit Assembly



Jeep Kit Assembly

Suggested Materials & Tools



Blue Painter's Tape



Model Master Model Glue



Flat Black



Color of Choice For Body



Document Protector (For Windows)

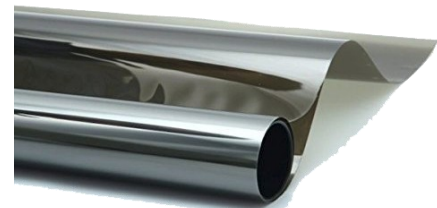

House Window Tinting

Jeep Kit Assembly

Suggested Materials & Tools (Con't)



**Testor's
Insignia Red**



**Testor's
Silver**



**Testor's
Insignia Red**



**Testor's
Yellow**



Small Brush



**Jeweler's
Side-Cutters**



**Sharp
Scissors**

Jeep Kit Assembly

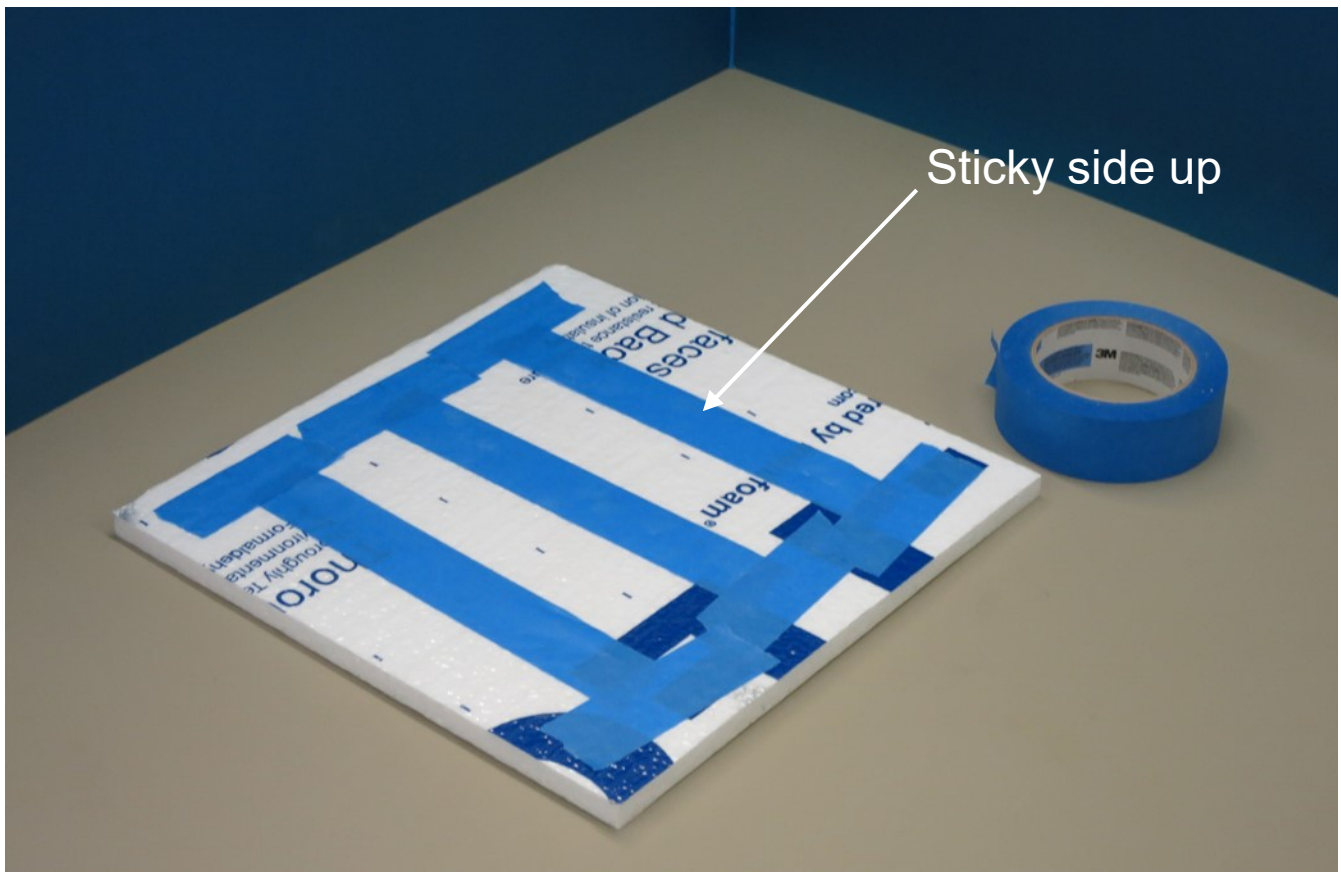

This is my way of painting small, light, plastic parts:

- Cut out a couple pieces of 1/2" foam insulation about 12" wide x 12" long to use as a holder while painting your parts. Lay one of the pieces flat on your workbench.
- Tear off 2 pieces of 1" blue painters tape about 3" long and tack them to the edge of your workbench.
- Tear off a piece of blue painter's tape about 8" long and place it along the middle of the piece of insulation with the sticky side up. Using one of the short pieces of tape, secure one end of this 8" piece of tape to the insulation. Stretch the 8" piece of tap across the insulation and secure the other end with a short piece of tape. Repeat this process for a as many rows as needed to paint all parts.
- Now, you have a sticky surface to hold your work while you paint.

Jeep Kit Assembly

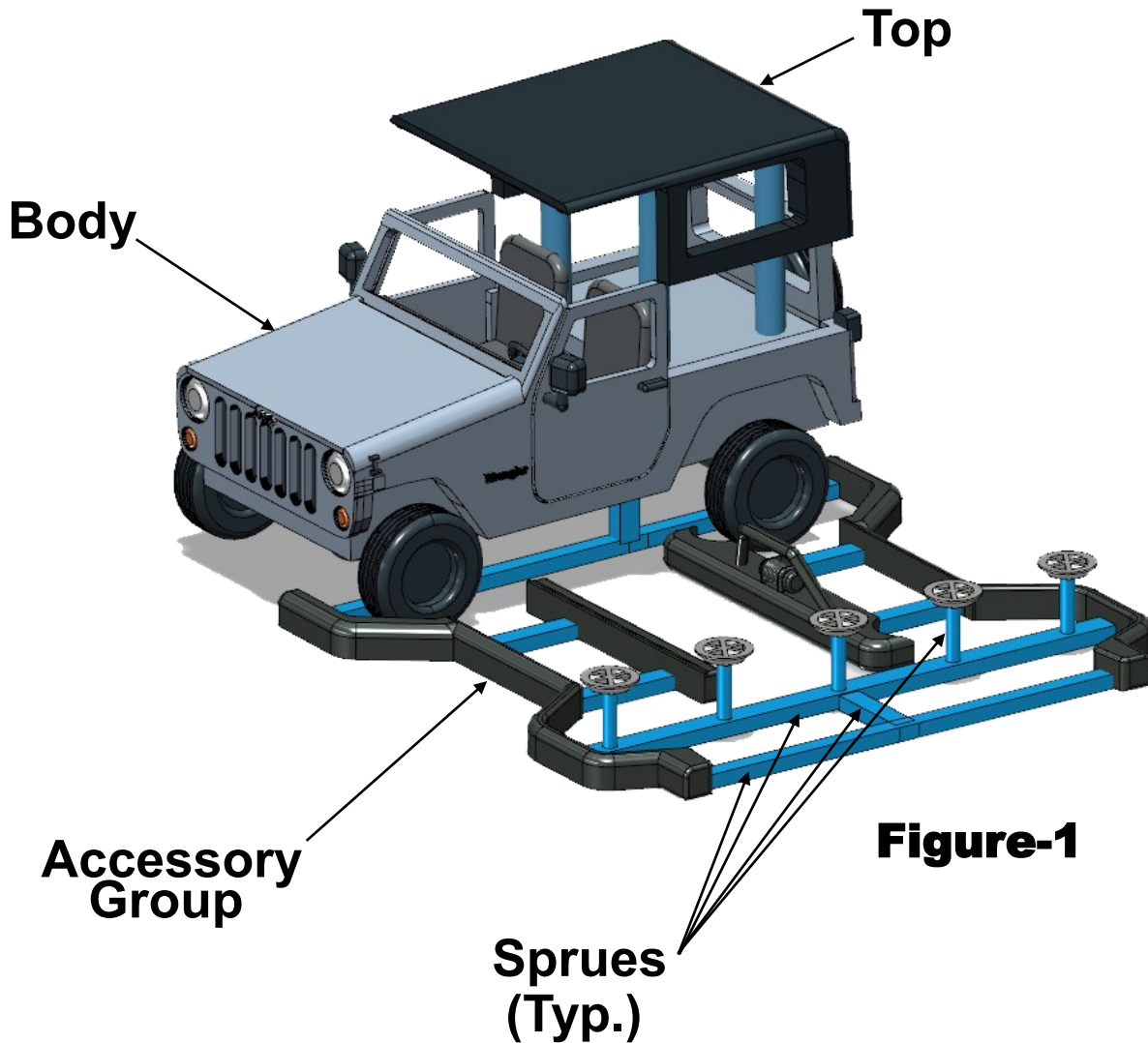

- The model is composed of 3-major component groups: Body, Top and Accessory Group, which includes the bumpers, fenders and wheel hubs.
- All parts are connected with sprues, similar to those found in injection-molded models. The sprues makes the whole model one integral part, which keeps the price of printing down. In the following steps, all sprues will be removed and can be discarded.

Jeep Kit Assembly

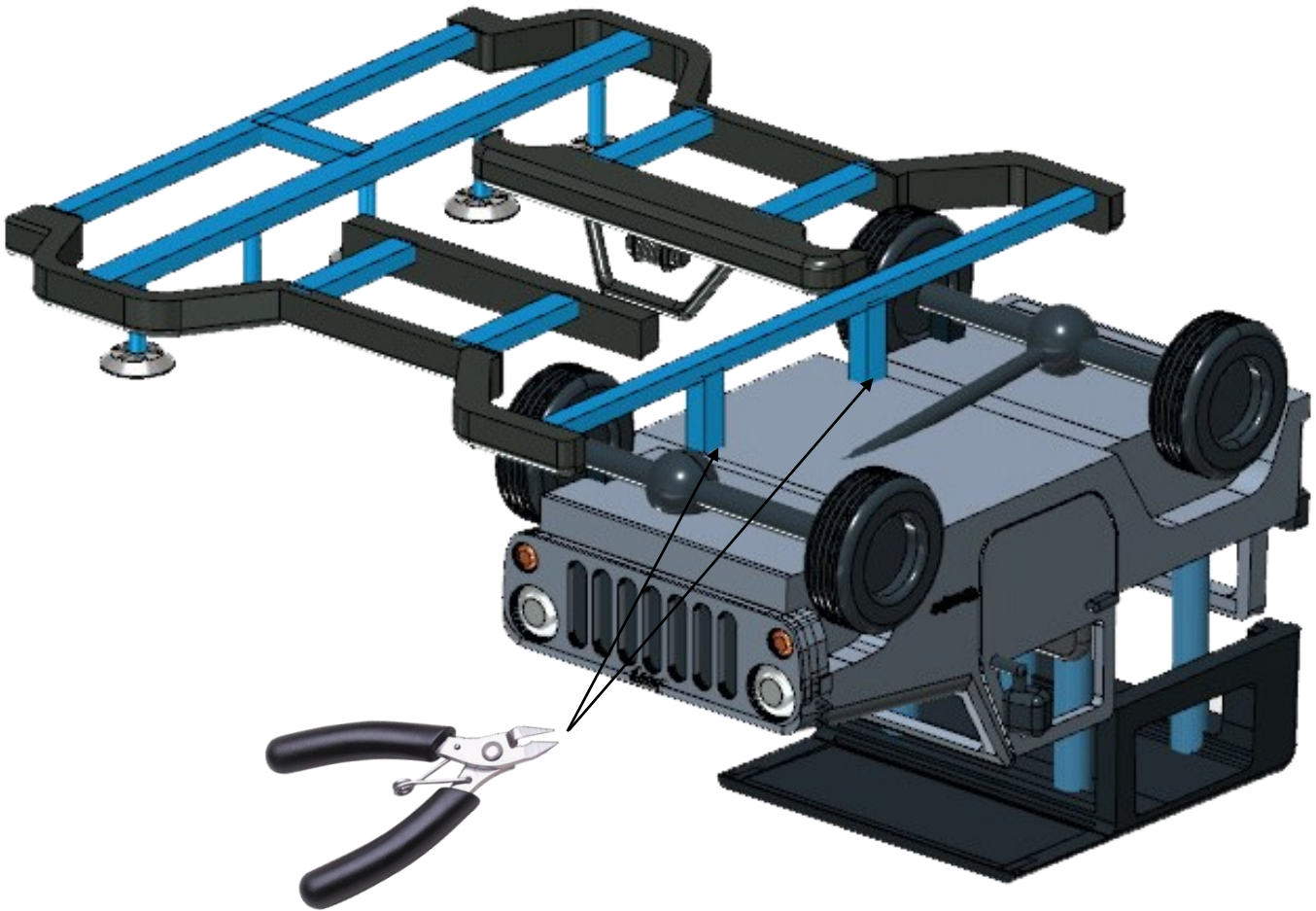

Figure-1

- Refer to Figure-1, above, and cut both sprues that connect the Jeep body and the accessory group as closely as possible to the bottom of the Jeep.
- Set aside the accessory group for now.

Jeep Kit Assembly

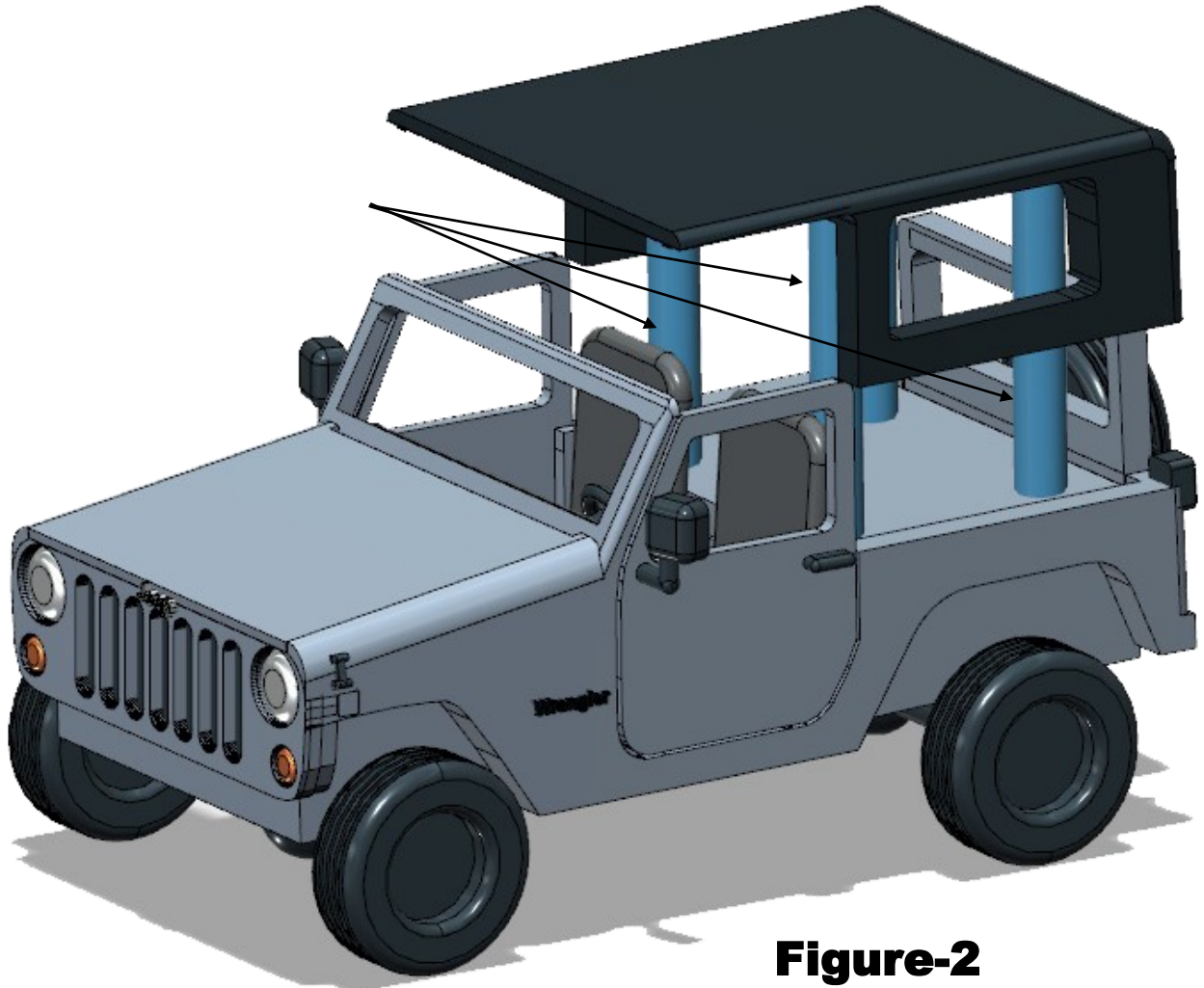

Figure-2

- Refer to Figure-2, above, and cut the 4-sprues that connect the top to the body. Carefully reach in through the openings with a jeweler's side-cutter and cut each sprue where practicable.
- Set aside the body.

Jeep Kit Assembly

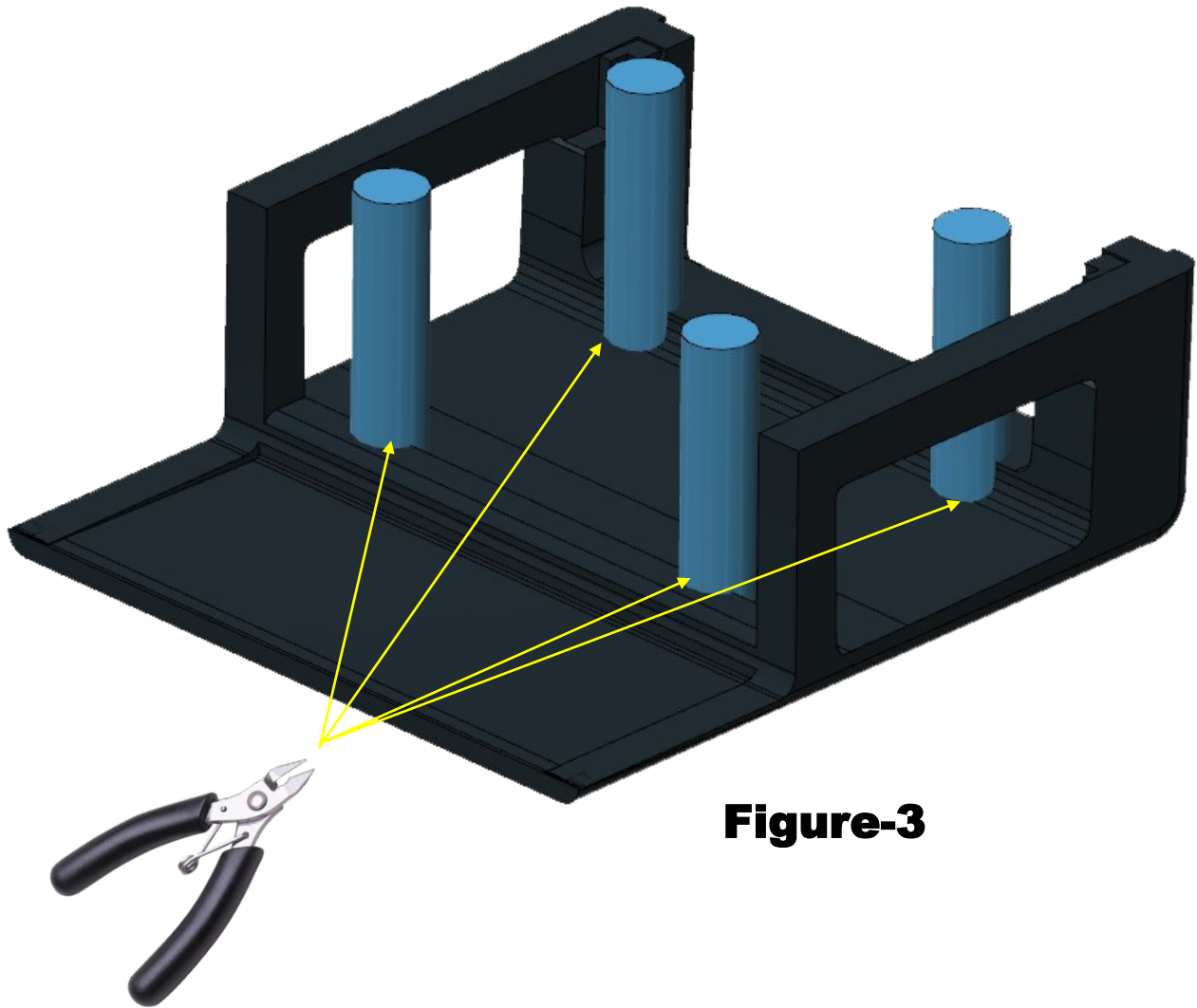

Figure-3

- Refer to Figure-3, above, and cut all four sprue stumps closely as possible to the inside of the top and discard.
- Spray paint the entire top flat black and set aside to dry.

Jeep Kit Assembly

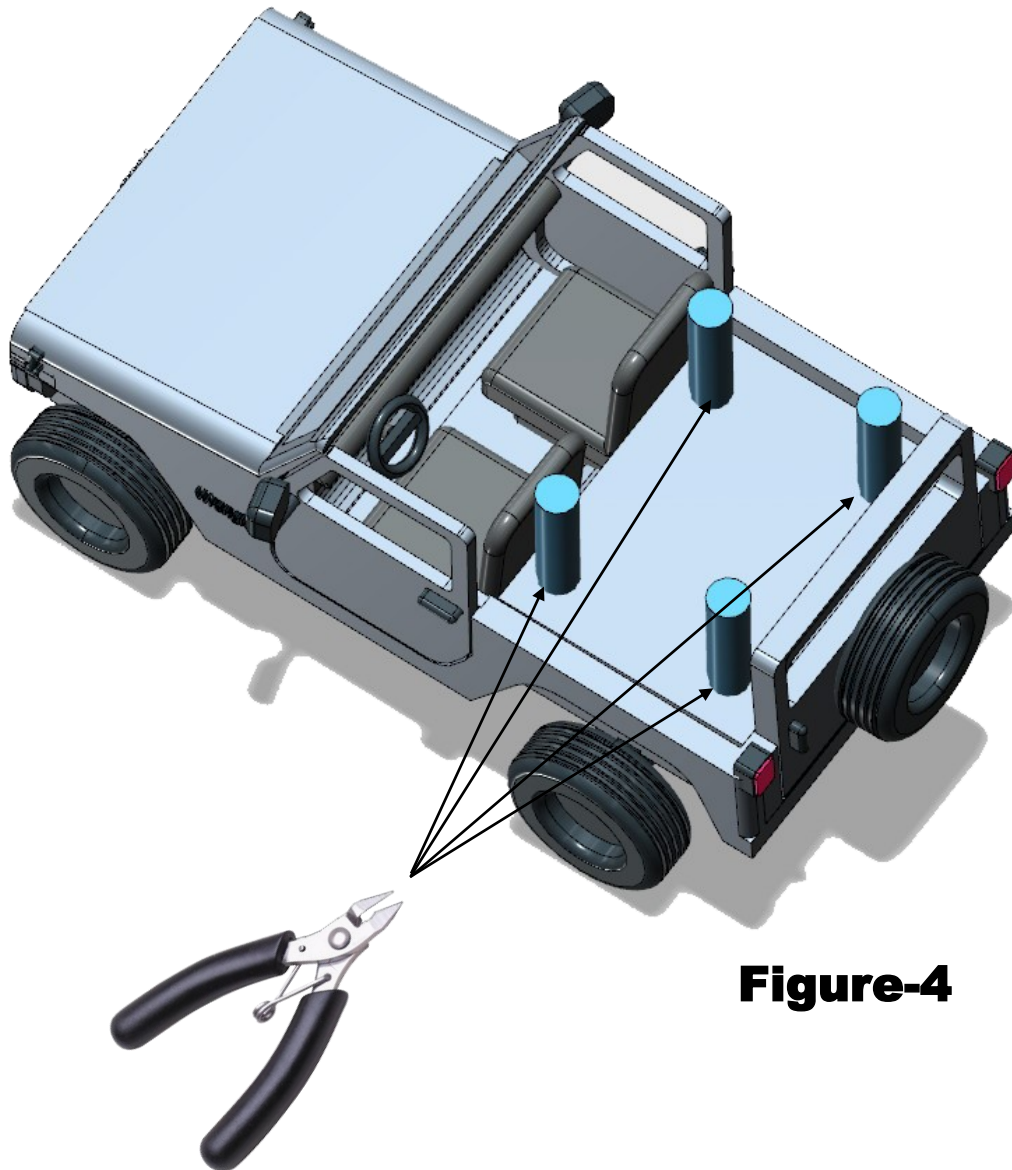
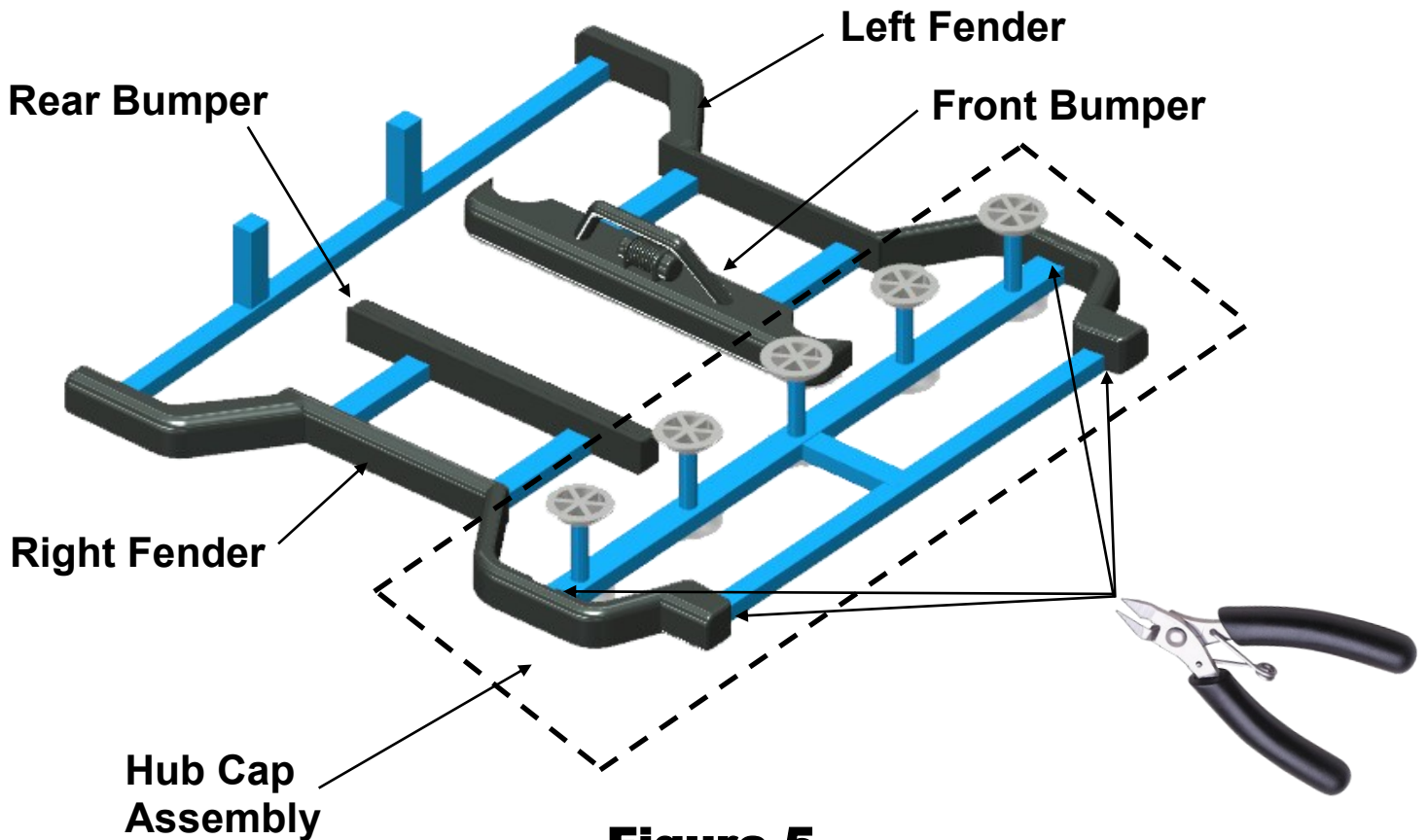

Figure-4

- Refer to Figure-4, above, and cut all 4-sprue stumps closely as possible to the inside of the body and discard.
- Spray paint the entire body a color of your choice and set aside to dry.

Jeep Kit Assembly



- Refer to Figure-5, above, and cut all four sprues that connect the hub cap assembly to the accessory group closely as possible to the inside of the fenders.
- Brush paint each hub cap silver and set aside to dry.
- Spray paint the remaining bumpers and fenders flat black and set aside to dry.

Jeep Kit Assembly

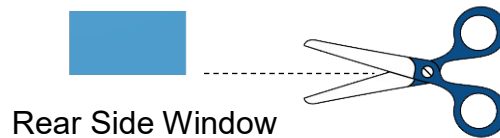

- **Print this page on a sheet of card stock paper.**
- **Use the cut-outs as a pattern to cut the windshield and door window out of a piece of clear document protector.**
- **Use the cut-outs to cut the rear and rear side windows from a piece of window tinting. Note: You may have to trim each window as you fit them in.**

Jeep Kit Assembly

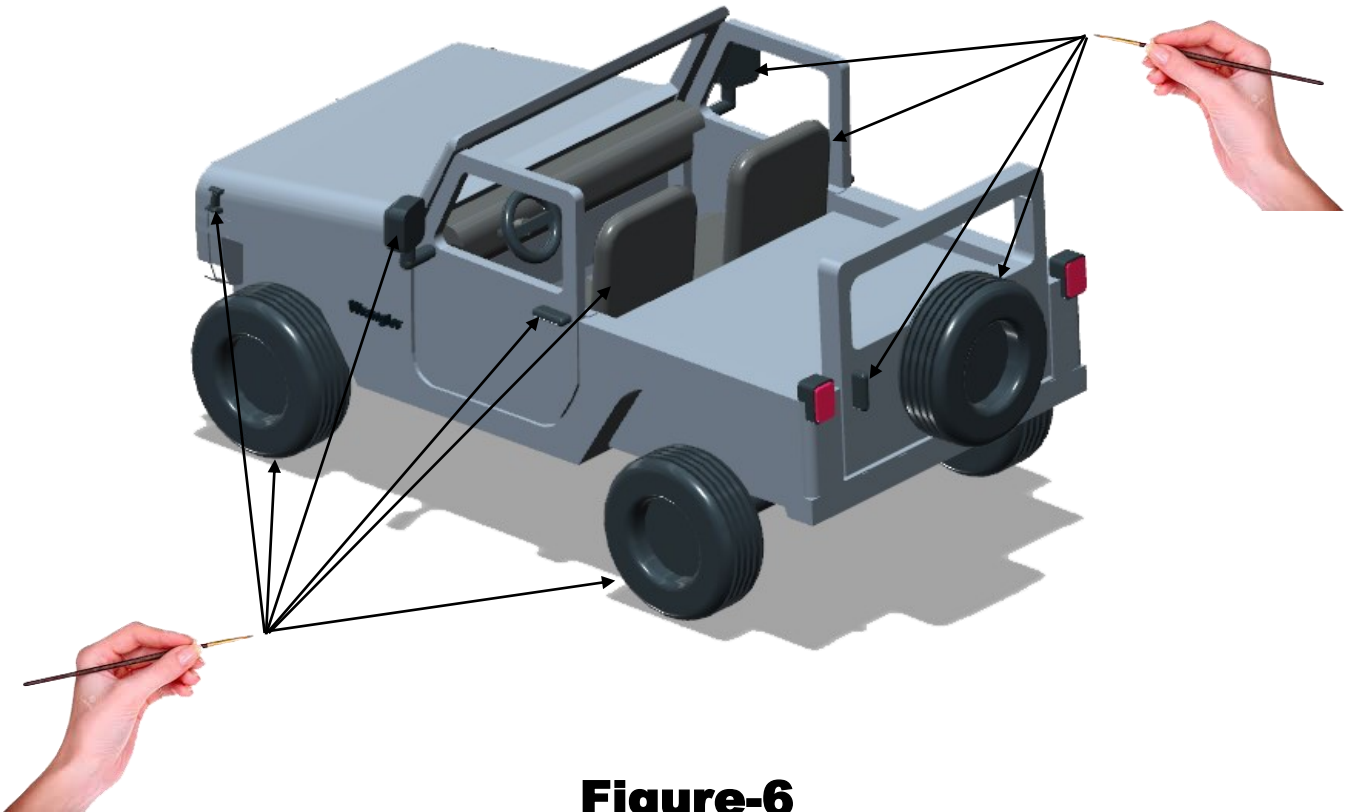
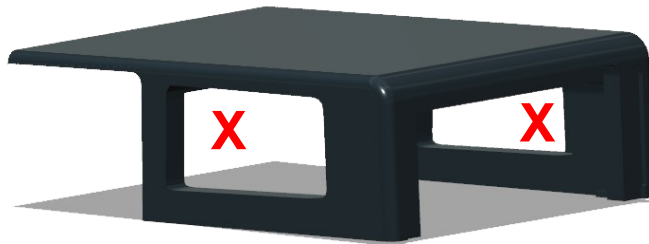
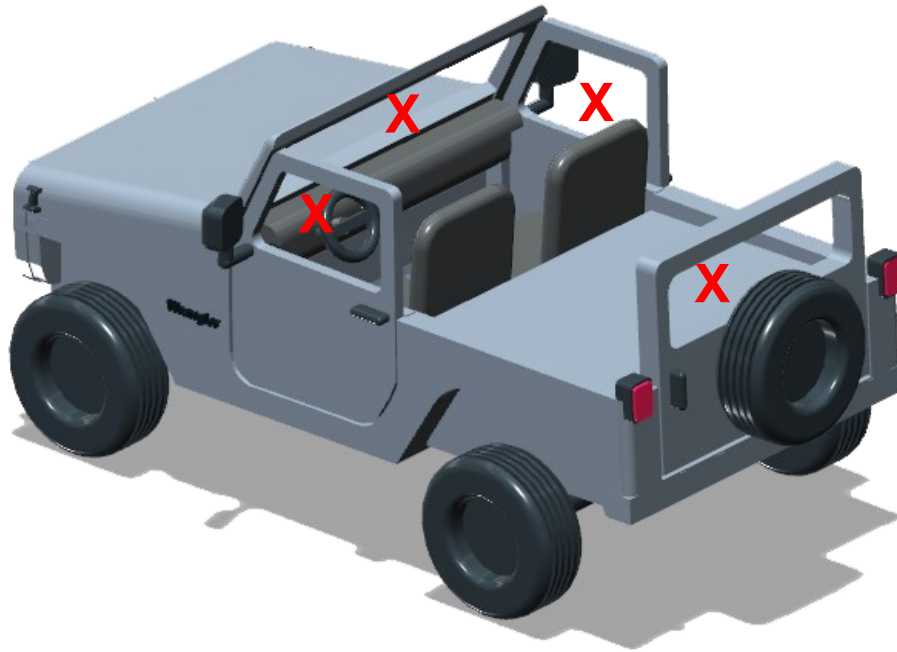

Figure-6

- Paint the tires, steering wheel, mirrors, seats, door handles and hood latches black or a dark gray with a small paint brush, using a latex paint.
- Let dry.

Jeep Kit Assembly



- **Affix each window by placing by placing them inside their appropriate window frame on the doors, front side windows and rear windows. Place a small drop of model glue at each corner and the middle of at least 2-side edges so the glue will draw slightly under the edges by capillary attraction.**

Jeep Kit Assembly

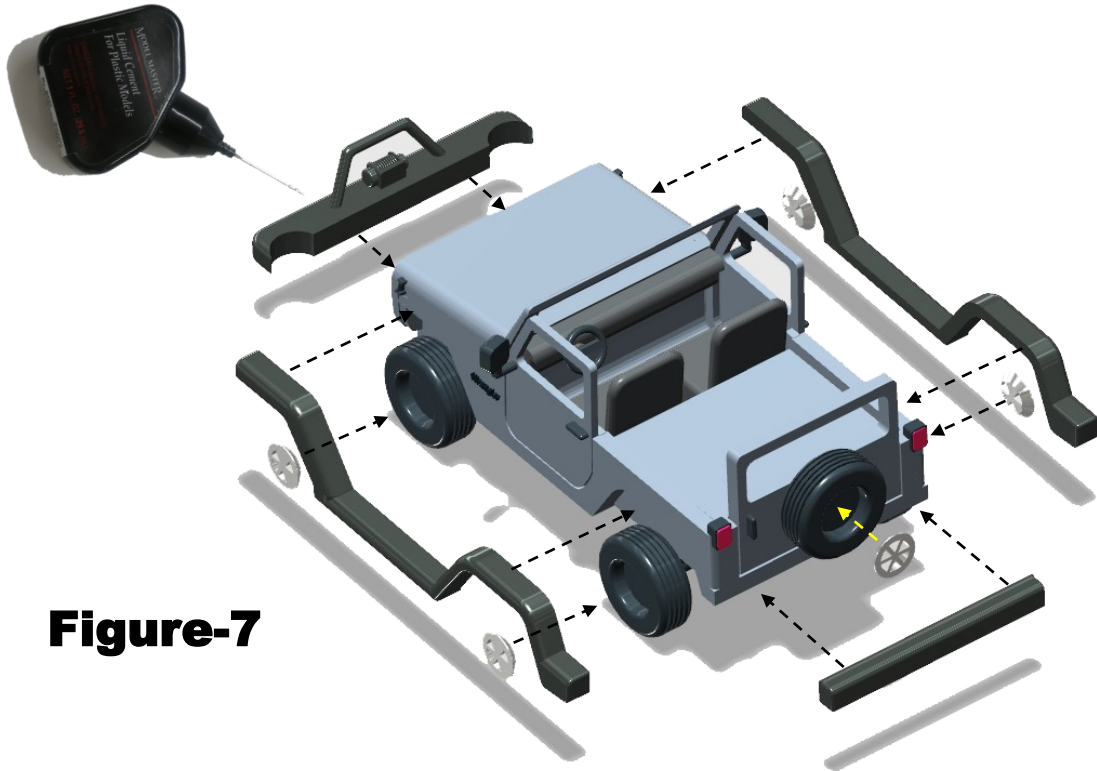

Figure-7

- Attach fenders and bumpers with model glue as shown in Figure-7.



Figure-8

- Attach Top with model glue as shown in Figure-8. Apply to door tops and window top.

Jeep Kit Assembly

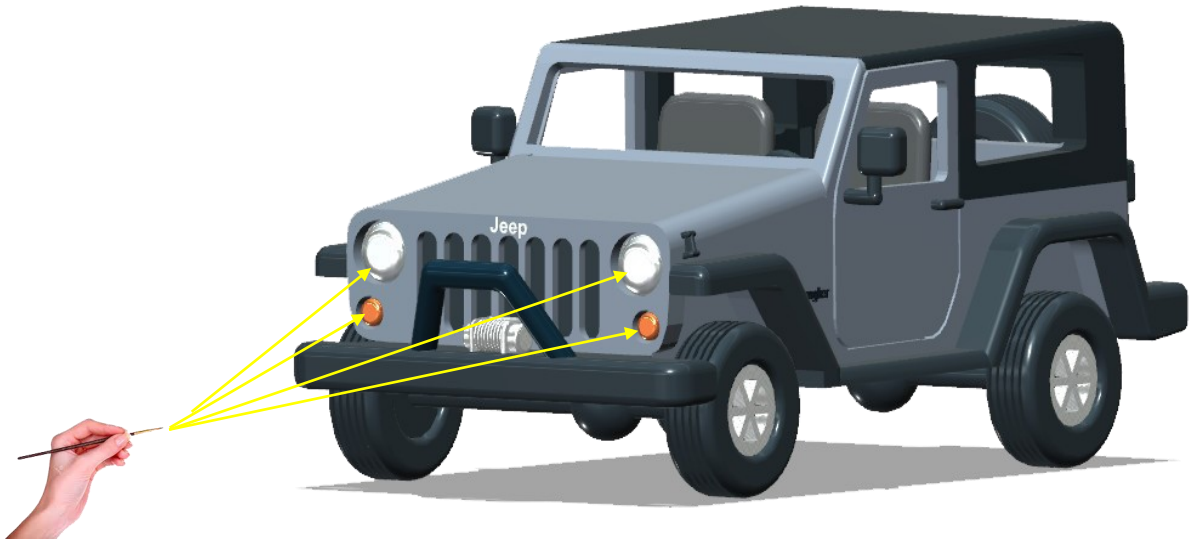

- Using Testor's model paint and a small brush, paint the headlights and winch silver and the parking lamps dark orange. (I suggest Mixing a small amount Testor's Insignia red and yellow paint to a dark orange.)

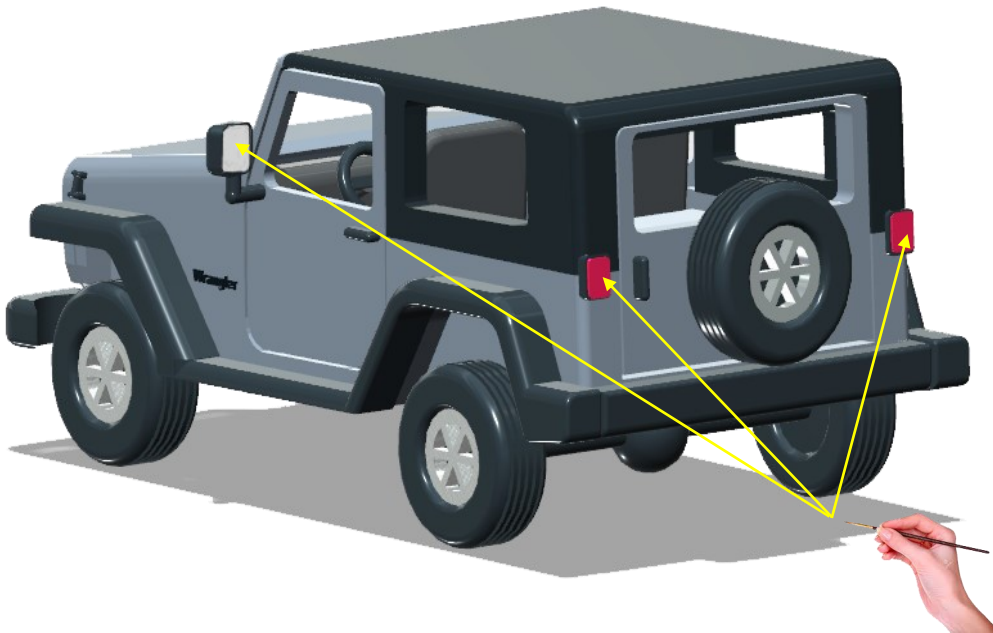

- Using Testor's model paint and a small brush, paint the Mirror silver and the taillights lights red.