

INSTRUCTION MANUAL

V-DrillGuide®

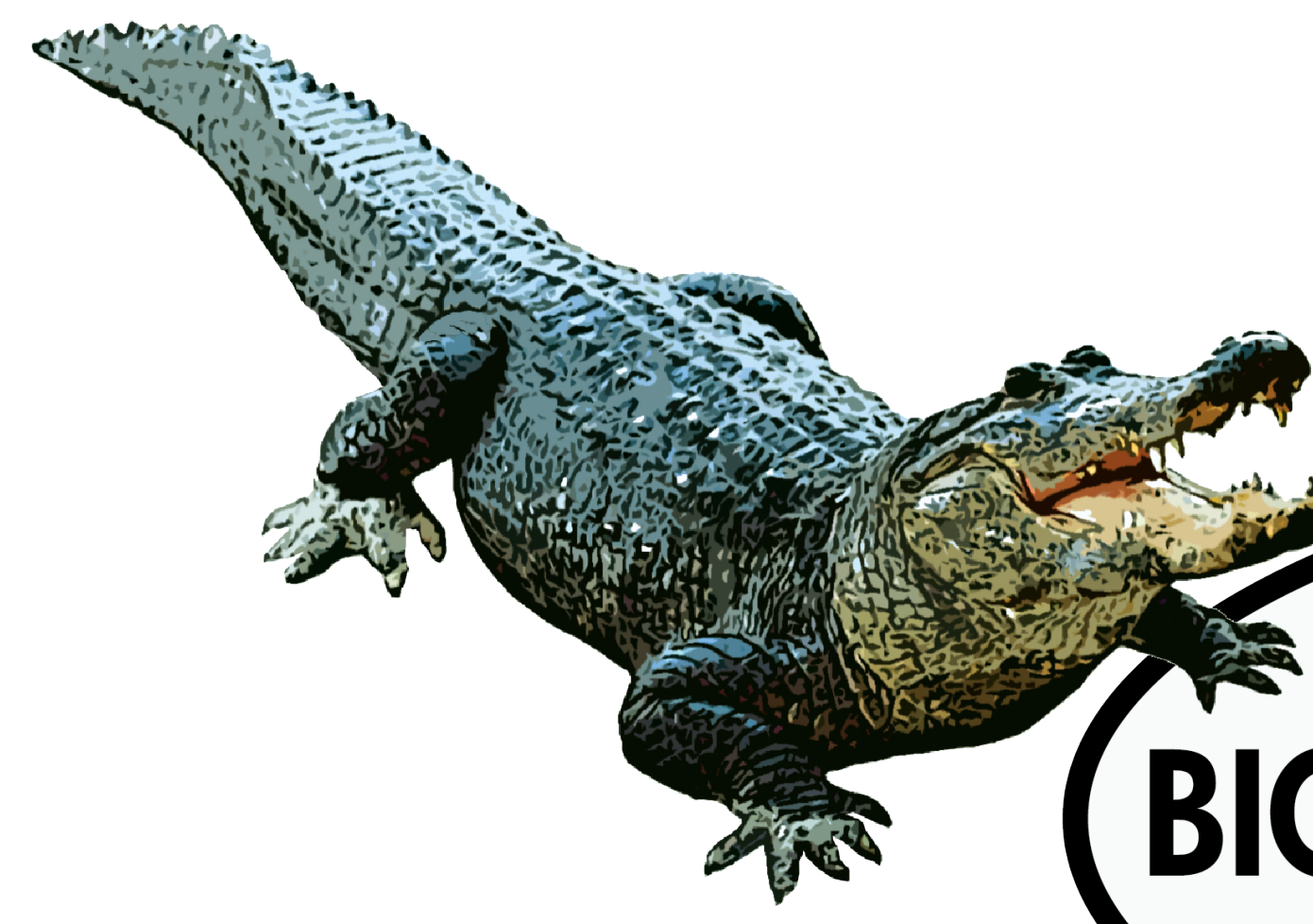

BIG GATOR TOOLS

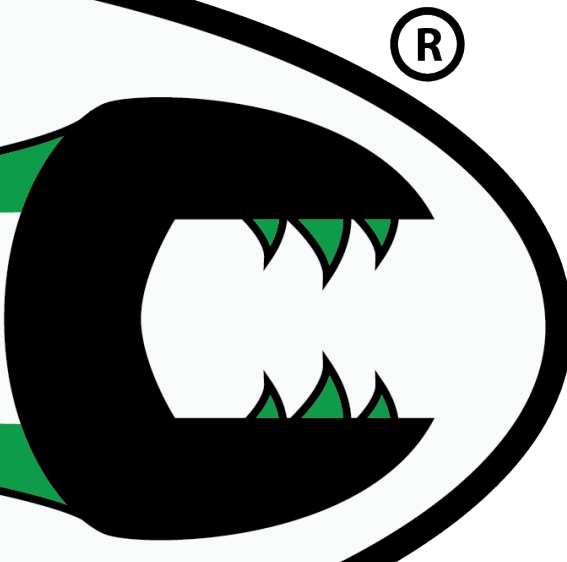

1 - Top

2 - Sides

3 - Drill bit holes

4 - Alignment marks

5 - V-Groove

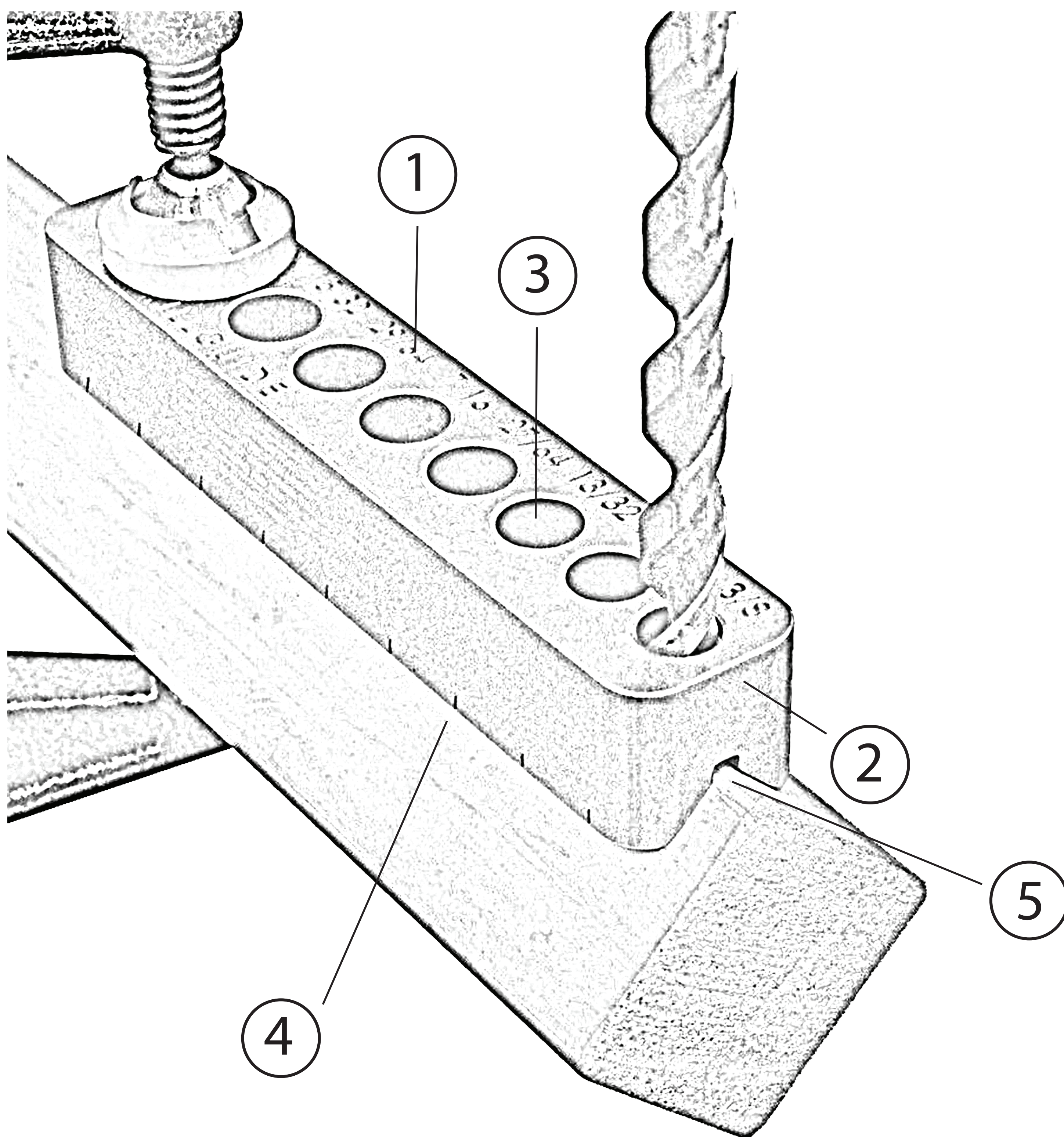
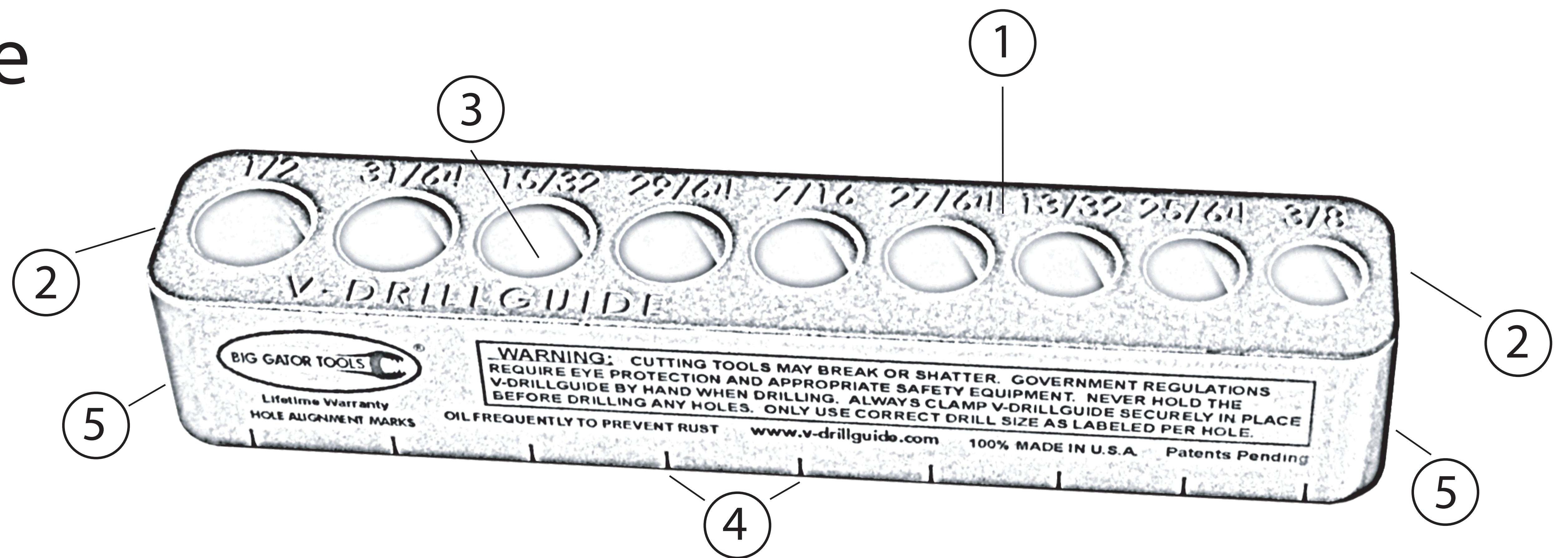

Various sizes of V-DrillGuides.
Images shown may look similar,
but may have different drill sizes.

INSTRUCTION MANUAL

V-DrillGuide®

WARNING: CUTTING TOOLS MAY BREAK OR SHATTER. GOVERNMENT REGULATIONS REQUIRE EYE PROTECTION AND APPROPRIATE SAFETY EQUIPMENT. NEVER HOLD V-DrillGuide® BY HAND WHEN DRILLING - ALWAYS CLAMP V-DrillGuide® SECURELY IN PLACE BEFORE DRILLING ANY HOLES. ONLY USE CORRECT DRILL SIZE AS LABELED PER HOLE.

BASIC OPERATION:

1. Mark the material of where you would like a hole drilled.
2. Place the V-DrillGuide® bottom/v-groove side down on the material you are wanting to drill.
3. Use alignment marks on either side of the V-DrillGuide to find your marks.
4. Clamp the V-DrillGuide securely to the material.
5. Use a drill bit appropriate to the drill hole.
6. Drill your hole.

V-Groove:

1. Use the V-Groove for round or cornered material.
2. Follow the same BASIC OPERATION information above.

Ground Base:

1. Use the base for flat materials to be drilled on.
2. Follow the same BASIC OPERATION information above.



Big Gator Tools Louisburg, Kansas
biggatortools.com
© 2023 Big Gator Tools

At Big Gator Tools we are constantly reviewing and improving our tools. The most current version of our instruction manuals are always available to download/print at biggatortools.com via the tool's page.



Contact: 1-888-Gator4u - sales@bgtools.com