

INSTRUCTION MANUAL

V-TapGuide®

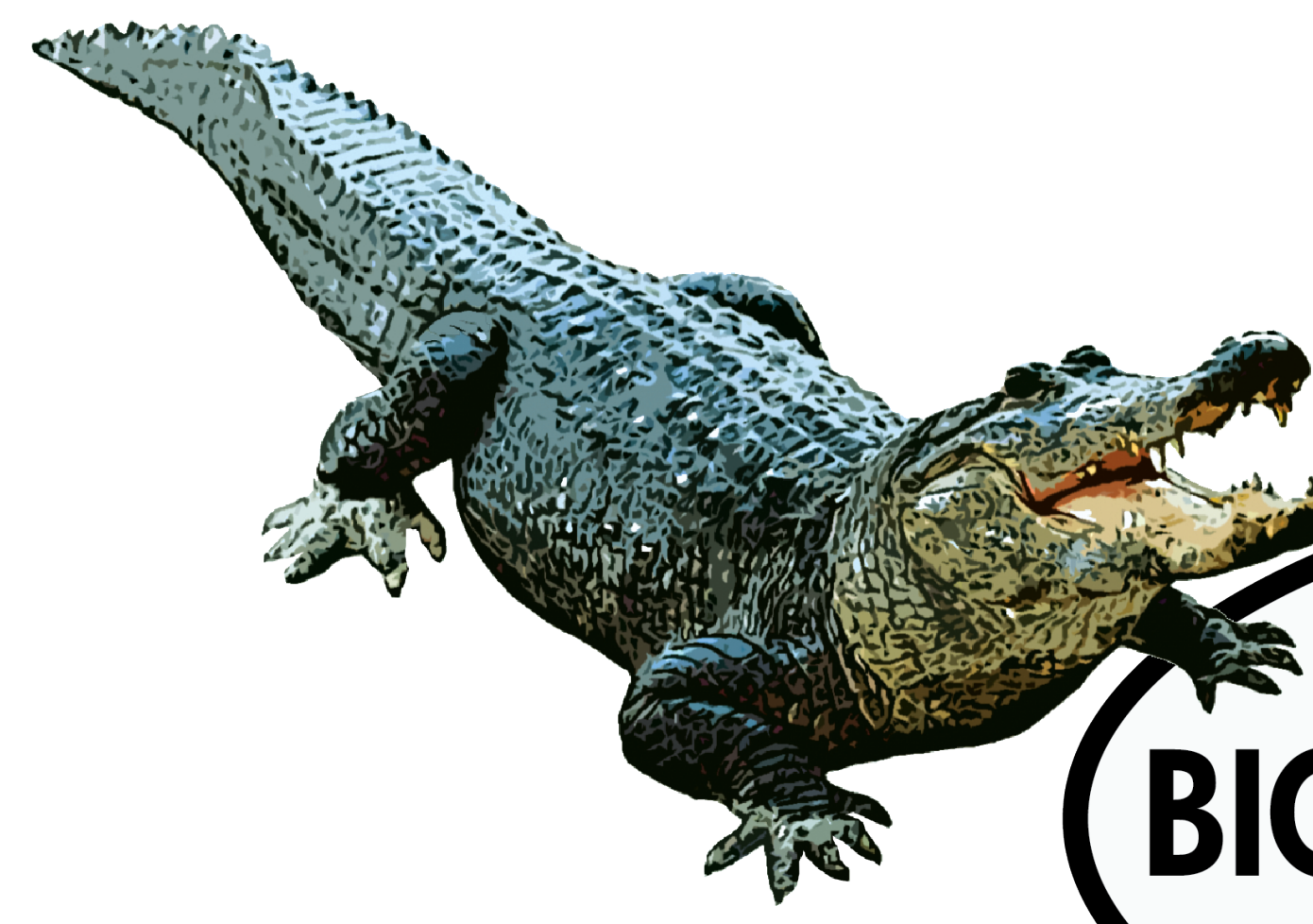

BIG GATOR TOOLS

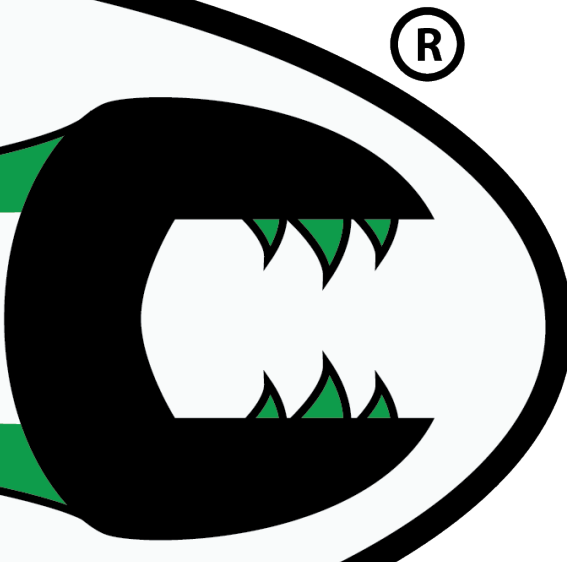

1 - Top

2 - Sides

3 - Tap holes

4 - V-Groove

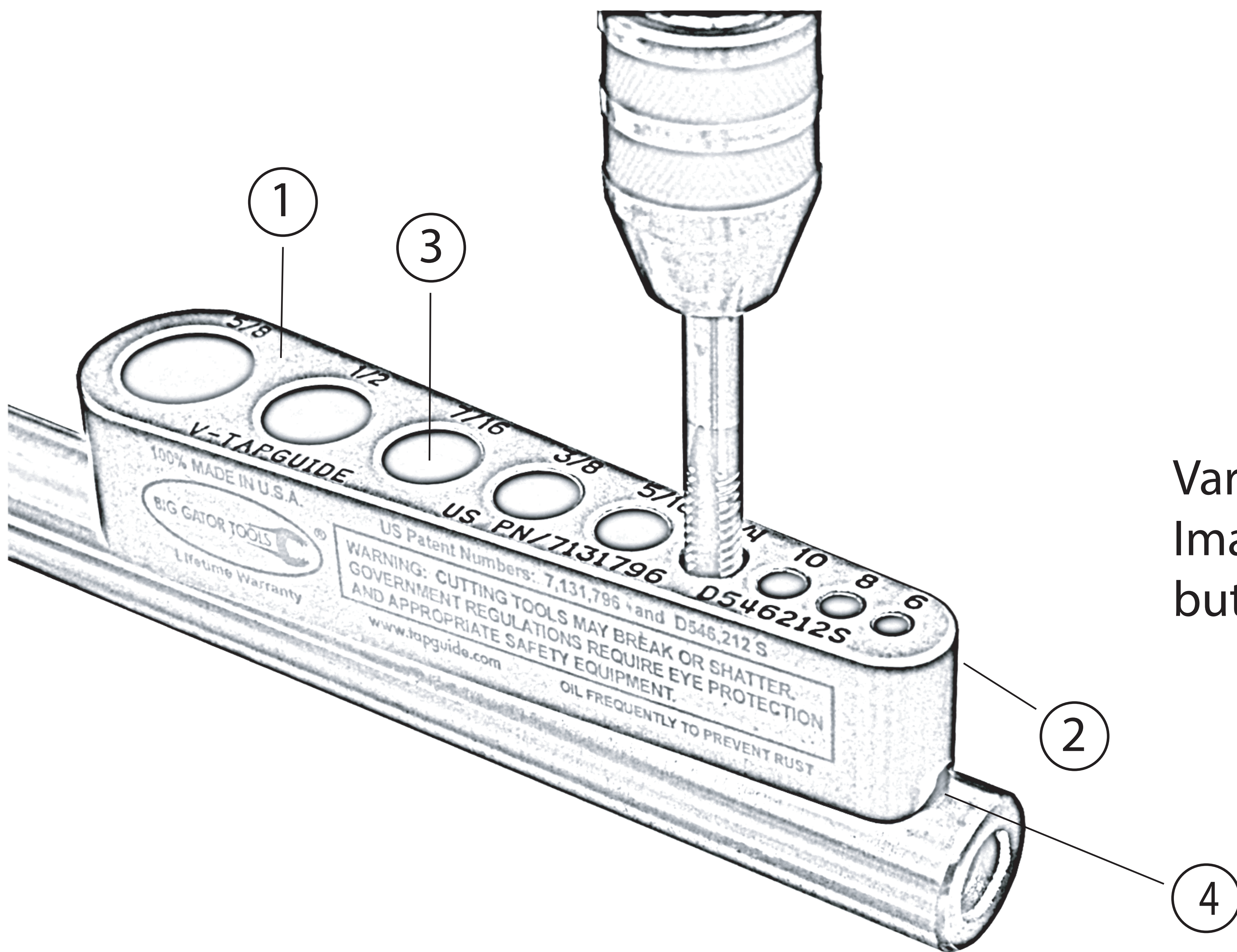
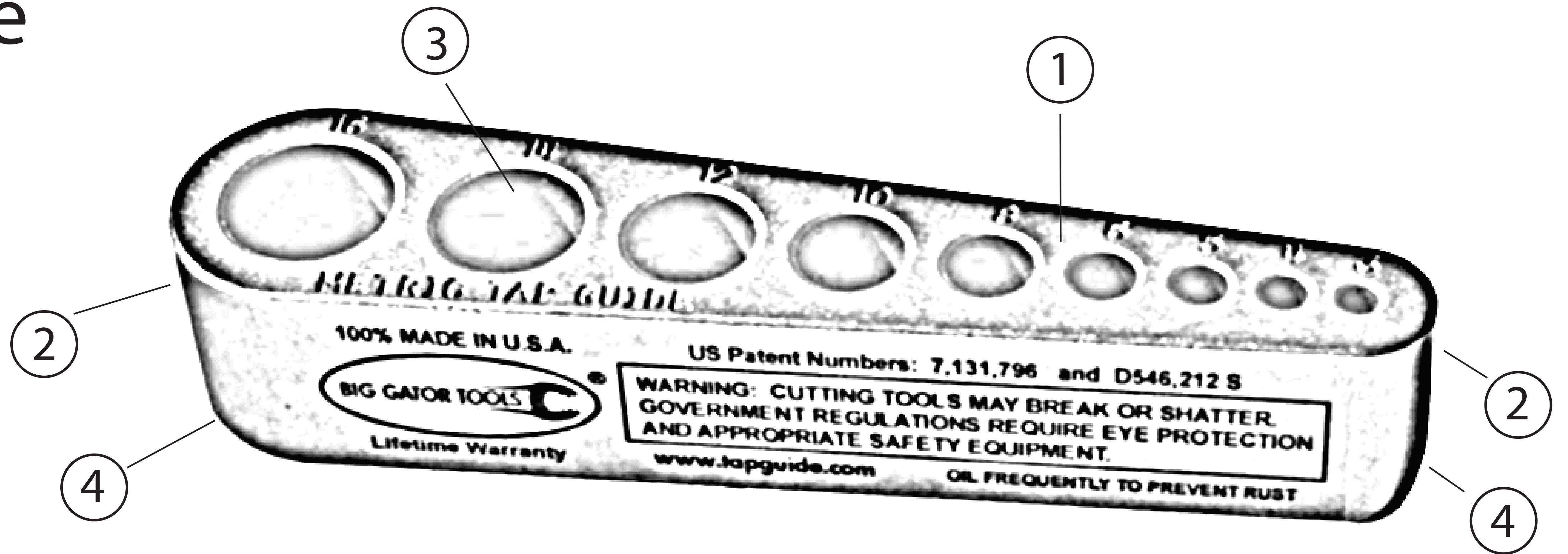

Various sizes of V-TapGuides.
Images shown may look similar,
but may have different tap sizes.

INSTRUCTION MANUAL

V-TapGuide®



WARNING: CUTTING TOOLS MAY BREAK OR SHATTER. GOVERNMENT REGULATIONS REQUIRE EYE PROTECTION AND APPROPRIATE SAFETY EQUIPMENT.

BASIC OPERATION:

Place the tap guide on the work surface with the “v-groove” side resting on the surface.

Insert the appropriate tap through the guide into the pre-drilled hole. Turn the tap clockwise.

The tap will then be aligned perpendicularly using the guide as the base; this will ensure straight and accurately tapped hole.

Every few turns, back the tap out counterclockwise to clear the chips. It's beneficial to hand tap because the tap resistance can be felt and that helps prevent tap breakage.

V-Groove:

1. Use the V-Groove for round or cornered material.
2. Follow the same BASIC OPERATION information above.

Ground Base:

1. Use the base for flat materials to be drilled on.
2. Follow the same BASIC OPERATION information above.



Big Gator Tools Louisburg, Kansas
biggatortools.com
© 2023 Big Gator Tools

At Big Gator Tools we are constantly reviewing and improving our tools. The most current version of our instruction manuals are always available to download/print at biggatortools.com via the tool's page.



Contact: 1-888-Gator4u - sales@bgtools.com
Big Gator Tools - U.S. Patent #7,131,796 & D546,212S - www.biggatortools.com