

Sweet Cutting Machine

Model no.: BCM-3

Machine images

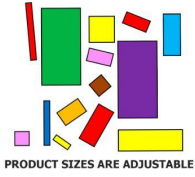

Sweets suitable for cutting in BCM-3



GHEE MYSORE PAK



COCONUT SWEETS



KALAKAND



KAJU ROLLS



DATES AND ANJEER BASED PRODUCTS



ALL TYPES OF MANGO BYTES PRODUCTS



DRY FRUITS BASED KARADANT



PALKOVA



HORLICKS BARFI



ALL TYPES OF HALWA



ALL TYPES OF BARFI

Technical Specifications

APPLICATION :

CUTTING DIFFERENT KINDS OF SWEETS IN VARIOUS SIZES.

ALL CONTACT PARTS :

STAINLESS STEEL 304

MODEL NO :

BCM-3

CAPACITY :

125-150 TRAYS PER DAY (2*2 FEET SIZE)

NEW ADDED FEATURES :

AUTOMATIC HOLDING UNIT WITH 2 NEW ADDED CYLINDERS

ELECTRIC SPECIFICATIONS :

220 VOLTS 60 HZ SINGLE PHASE

PNEUMATIC BRAND :

JENETICS

CONTROL SYSTEM :

KINCO

SWEET BATCH SIZE :

MAXIMUM 22*22 INCH

Machine dimensions

WIDTH : 87 INCH

BREADTH : 31 INCH

HEIGHT : 62 INCH

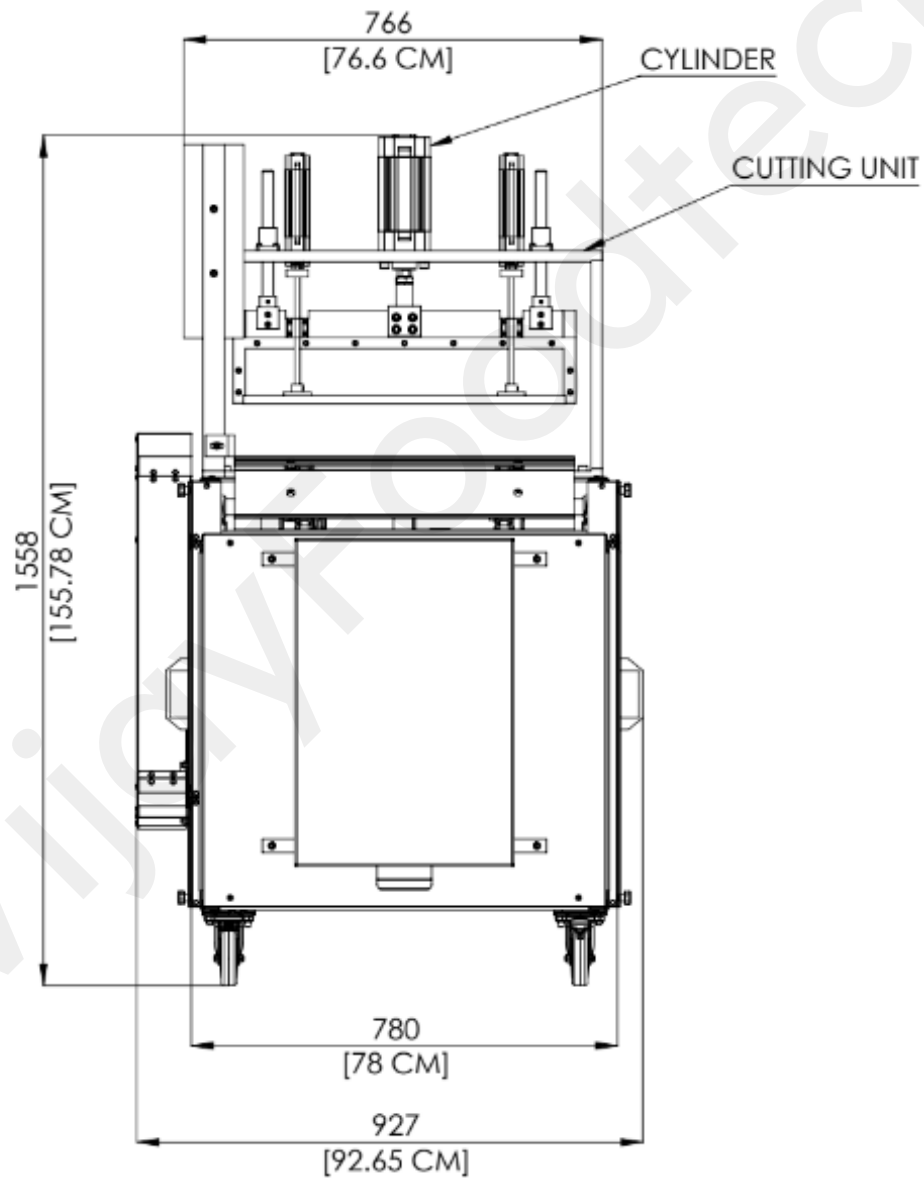

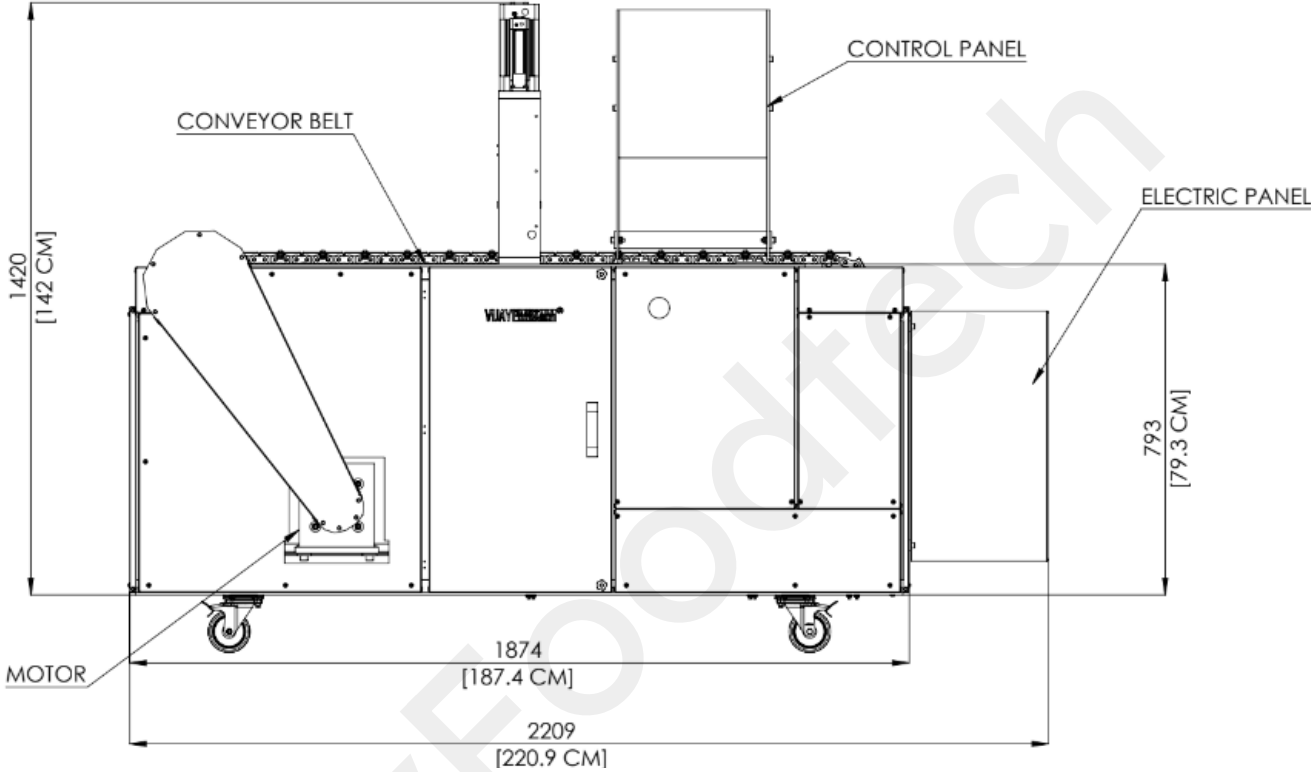

Wooden box dimensions

WIDTH : 93 INCH

BREADTH : 41 INCH

HEIGHT : 55 INCH



Spare parts included

Sr no.	Item	Quantity
1.	Extra BCM-3 blades	2
2.	Basic tool kit	1
3.	Stainless steel cutting base tray	2

NOTE: COMPRESSOR REQUIRED 1.5 HP NOT INCLUDED.

Some of our customers

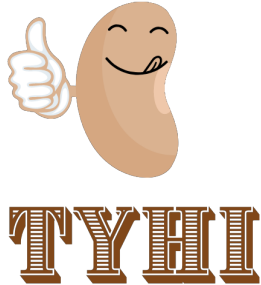

INNOVATIVE NUTRICHEM PRIVATE
LIMITED



TAMILNADU CO-OPERATIVE MILK
PRODUCERS' FEDERATION LIMITED



Quality & Goodness since 1953

KARACHI SWEET DELICACIES



DHARWAD MISHRA PEDHA & FOOD
PROCESSING INDUSTRY